

SIMATIC

S7-200 Programmable Controller System Manual

Preface, Contents	
Product Overview	1
Getting Started	2
Installing the S7-200	3
PLC Concepts	4
Programming Concepts, Conventions and Features	5
S7-200 Instruction Set	6
Communicating over a Network	7
Hardware Troubleshooting Guide and Software Debugging Tools	8
Creating a Program for the Position Module	9
Creating a Program for the Modem Module	10
Using the USS Protocol Library to Control a MicroMaster Drive	11
Using the Modbus Protocol Library	12
Technical Specifications	A
Calculating a Power Budget	B
Error Codes	C
Special Memory (SM) Bits	D
S7-200 Order Numbers	E
Execution Times for STL Instructions	F
S7-200 Quick Reference Information	G
Index	

This manual has the order number:
6ES7298-8FA22-8BH0

Edition 04/2002

A5E00157957-01

Safety Guidelines

This manual contains notices which you should observe to ensure your own personal safety, as well as to protect the product and connected equipment. These notices are highlighted in the manual by a warning triangle and are marked as follows according to the level of danger:



Danger

Danger indicates an imminently hazardous situation which, if not avoided, will result in death or serious injury.



Warning

Warning indicates a potentially hazardous situation which, if not avoided, could result in death or serious injury.



Caution

Caution used with the safety alert symbol indicates a potentially hazardous situation which, if not avoided, may result in minor or moderate injury.

Caution

Caution used without the safety alert symbol indicates a potentially hazardous situation which, if not avoided, may result in property damage.

Notice

Notice indicates a potential situation which, if not avoided, may result in an undesirable result or state.

Qualified Personnel

Only **qualified personnel** should be allowed to install and work on this equipment. Qualified persons are defined as persons who are authorized to commission, to ground, and to tag circuits, equipment, and systems in accordance with established safety practices and standards.

Correct Usage

Note the following:



Warning

This device and its components may only be used for the applications described in the catalog or the technical descriptions, and only in connection with devices or components from other manufacturers which have been approved or recommended by Siemens.

This product can only function correctly and safely if it is transported, stored, set up, and installed correctly, and operated and maintained as recommended.

Trademarks

SIMATIC®, SIMATIC HMI® and SIMATIC NET® are registered trademarks of SIEMENS AG.

Some of other designations used in these documents are also registered trademarks; the owner's rights may be violated if they are used by third parties for their own purposes.

Copyright Siemens AG 2002 All rights reserved

The reproduction, transmission or use of this document or its contents is not permitted without express written authority. Offenders will be liable for damages. All rights, including rights created by patent grant or registration of a utility model or design, are reserved.

Siemens AG
Bereich Automation and Drives
Geschäftsgebiet Industrial Automation Systems
Postfach 4848, D- 90327 Nuernberg

Siemens Aktiengesellschaft

Disclaimer of Liability

We have checked the contents of this manual for agreement with the hardware and software described. Since deviations cannot be precluded entirely, we cannot guarantee full agreement. However, the data in this manual are reviewed regularly and any necessary corrections included in subsequent editions. Suggestions for improvement are welcomed.

© Siemens AG 2002
Technical data subject to change.

6ES7298-8FA22-8BH0



Preface

The S7-200 series is a line of micro-programmable logic controllers (Micro PLCs) that can control a variety of automation applications. Compact design, low cost, and a powerful instruction set make the S7-200 a perfect solution for controlling small applications. The wide variety of S7-200 models and the Windows-based programming tool give you the flexibility you need to solve your automation problems.

Audience

This manual provides information about installing and programming the S7-200 Micro PLCs and is designed for engineers, programmers, installers, and electricians who have a general knowledge of programmable logic controllers.

Scope of the Manual

The information contained in this manual pertains in particular to the following products:

- S7-200 CPU models: CPU 221, CPU 222, CPU 224, CPU 226, and CPU 226XM
- S7-200 EM 22x expansion modules
- STEP 7-Micro/WIN, version 3.2, a 32-bit programming software package for the S7-200
- STEP 7-Micro/WIN Instruction Libraries and TP-Designer for TP070, Version 1.0, a set of software tools for customers who use an S7-200 with other components, such as the TP070 Touch Panel, Modbus, or a MicroMaster drive

Standards Compliance

The SIMATIC S7-200 series meets the following standards:

- European Community (CE) Low Voltage Directive 73/23/EEC
EN 61131-2: Programmable Controllers - Equipment requirements
- European Community (CE) EMC Directive 89/336/EEC
Electromagnetic emissions standard
EN 50081-1: residential, commercial, and light industry
EN 50081-2: industrial environment
Electromagnetic immunity standards
EN 61000-6-2: industrial environment
- Underwriters Laboratories, Inc.
UL 508 Listed (Industrial Control Equipment) Registration number E75310
- Canadian Standards Association: CSA C22.2 Number 142 Certified (Process Control Equipment)
- Factory Mutual Research: FM Class I, Division 2, Groups A, B, C, & D Hazardous Locations, T4A and Class I, Zone 2, IIC, T4

Refer to Appendix A for compliance information.

Maritime Approvals

At the time this manual was printed, the SIMATIC S7-200 series met the maritime agencies identified below. For the latest product approvals, contact your local Siemens distributor or sales office.

Agency	Certificate Number
Lloyds Register of Shipping (LRS)	99 / 20018(E1)
American Bureau of Shipping (ABS)	01-HG20020-PDA
Germanischer Lloyd (GL)	12 045 - 98 HH
Det Norske Veritas (DNV)	A-8071
Bureau Veritas (BV)	09051 / A2 BV
Nippon Kaiji Kyokai (NK)	A-534

How to Use This Manual

If you are a first-time (novice) user of S7-200 Micro PLCs, you should read the entire *S7-200 Programmable Controller System Manual*. If you are an experienced user, refer to the table of contents or index to find specific information.

The *S7-200 Programmable Controller System Manual* is organized according to the following topics:

- Chapter 1 (Product Overview) provides an overview of some of the features of the S7-200 family of Micro PLC products.
- Chapter 2 (Getting Started) provides a tutorial for creating and downloading a sample control program to an S7-200.
- Chapter 3 (Installing the S7-200) provides the dimensions and basic guidelines for installing the S7-200 CPU modules and expansion I/O modules.
- Chapter 4 (PLC Concepts) provides information about the operation of the S7-200.
- Chapter 5 (Programming Concepts, Conventions, and Features) provides information about the features of STEP 7-Micro/WIN, the program editors and types of instructions (IEC 1131-3 or SIMATIC), S7-200 data types, and guidelines for creating programs.
- Chapter 6 (S7-200 Instruction Set) provides descriptions and examples of programming instructions supported by the S7-200.
- Chapter 7 (Communicating over a Network) provides information for setting up the different network configurations supported by the S7-200.
- Chapter 8 (Hardware Troubleshooting Guide and Software Debugging Tools) provides information for troubleshooting problems with the S7-200 hardware and about the STEP 7-Micro/WIN features that help you debug your program.
- Chapter 9 (Creating a Program for the Position Module) provides information about the instructions and wizard used to create a program for the EM 253 Position module.
- Chapter 10 (Creating a Program for the Modem Module) provides information about the instructions and wizard used to create a program for the EM 241 Modem module.
- Chapter 11 (Using the USS Protocol Library to Control a MicroMaster Drive) provides information about the instructions used to create a control program for a MicroMaster drive. It also provides information about how to configure the MicroMaster 3 and MicroMaster 4 drives.
- Chapter 12 (Using the Modbus Protocol Library) provides information about the instructions used to create a program that uses the Modbus protocol for communications.
- Appendix A (Technical Specifications) provides the technical information and data sheets about the S7-200 hardware.

The other appendices provide additional reference information, such as descriptions of the error codes, descriptions of the Special Memory (SM) area, part numbers for ordering S7-200 equipment, and STL instruction execution times.

Additional Information and Assistance

Information about the S7-200 and STEP 7-Micro/WIN

In addition to this manual, STEP 7-Micro/WIN provides extensive online help for getting started with programming the S7-200. Included with the purchase of the STEP 7-Micro/WIN software is a free documentation CD. On this CD you can find application tips, an electronic version of this manual and other information.

Online Help

Help is only a keystroke away! Pressing F1 accesses the extensive online help for STEP 7-Micro/WIN. The online help includes useful information about getting started with programming the S7-200, as well as many other topics.

Electronic Manual

An electronic version of this S7-200 System Manual is available on the documentation CD. You can install the electronic manual onto your computer so that you can easily access the information in the manual while you are working with the STEP 7-Micro/WIN software.

Tips and Tricks

The documentation CD includes Tips and Tricks, a set of application examples with sample programs. Reviewing or modifying these examples can help you find efficient or innovative solutions for your own application. You can also find the most current version of Tips and Tricks on the S7-200 Internet site.

Internet: www.siemens.com/S7-200

For additional information about Siemens products and services, technical support, frequently asked questions (FAQs), product updates, or application tips, refer to the following Internet addresses:

- www.ad.siemens.de *for general Siemens information*

This Siemens Automation & Drives Internet site includes information about the SIMATIC product line and other products available from Siemens.

- www.siemens.com/S7-200 *for S7-200 product information*

The S7-200 Internet site includes frequently asked questions (FAQs), Tips and Tricks (application examples and sample programs), information about newly released products, and product updates or downloads.

Technical Assistance and Purchasing S7-200 Products

Local Siemens Sales Office or Distributor

For assistance in answering any technical questions, for training on the S7-200 products, or for ordering S7-200 products, contact your Siemens distributor or sales office. Because your sales representatives are technically trained and have the most specific knowledge about your operations, process and industry, as well as about the individual Siemens products that you are using, they can provide the fastest and most efficient answers to any problems that you might encounter.

Technical Services

The highly trained staff of the S7-200 Technical Services center is also available to help you solve any problems that you might encounter. You can call on them 24 hours a day, 7 days a week:

- For calls originating from within the United States of America*
 - Local time: Monday to Friday 0800 to 1900 Eastern time
 - Telephone: +1 800 241-4453
 - Fax: +1 (0) 770 740-3699
 - E-Mail: drives.support@sea.siemens.com

- For calls originating from the Americas outside of the USA*
 - Local time: Monday to Friday 0800 to 1900 Eastern time
 - Telephone: +1 (0) 770 740-3505
 - Fax: +1 (0) 770 740-3699
 - E-Mail: drives.support@sea.siemens.com

- For calls originating from Europe and Africa*
 - Local time (Nuremberg): Monday to Friday 0700 to 1700
 - Telephone: +49 (0) 180 5050-222
 - Fax: +49 (0) 180 5050-223
 - E-Mail: techsupport@ad.siemens.de

- For calls originating from Asia and Australia*
 - Local time (Singapore): Monday to Friday 0830 to 1730
 - Telephone: +65 (0) 740-7000
 - Fax: +65 (0) 740-7001
 - E-Mail: drives.support@sae.siemens.com.sg

Contents

1	Product Overview	1
	S7-200 CPU	2
	S7-200 Expansion Modules	3
	STEP 7-Micro/WIN Programming Package	3
	Communications Options	4
	Display Panels	4
2	Getting Started	5
	Connecting the S7-200 CPU	6
	Creating a Sample Program	8
	Downloading the Sample Program	11
	Placing the S7-200 in RUN Mode	11
3	Installing the S7-200	13
	Guidelines for Installing S7-200 Devices	14
	Installing and Removing the S7-200 Modules	15
	Guidelines for Grounding and Wiring	18
4	PLC Concepts	21
	Understanding How the S7-200 Executes Your Control Logic	22
	Accessing the Data of the S7-200	24
	Understanding How the S7-200 Saves and Restores Data	34
	Storing Your Program on a Memory Cartridge	36
	Selecting the Operating Mode for the S7-200 CPU	37
	Using Your Program to Save V Memory to the EEPROM	38
	Features of the S7-200	39
5	Programming Concepts, Conventions, and Features	47
	Guidelines for Designing a Micro PLC System	48
	Basic Elements of a Program	49
	Using STEP 7-Micro/WIN to Create Your Programs	51
	Choosing Between the SIMATIC and IEC 1131-3 Instruction Sets	53
	Understanding the Conventions Used by the Program Editors	54
	Using Wizards To Help You Create Your Control Program	56
	Handling Errors in the S7-200	56
	Assigning Addresses and Initial Values in the Data Block Editor	58
	Using the Symbol Table for Symbolic Addressing of Variables	58
	Using Local Variables	59
	Using the Status Chart to Monitor Your Program	59
	Creating an Instruction Library	60
	Features for Debugging Your Program	60

6	S7-200 Instruction Set	61
	Conventions Used to Describe the Instructions	63
	S7-200 Memory Ranges and Features	64
	Bit Logic Instructions	66
	Contacts	66
	Coils	68
	Logic Stack Instructions	70
	Set and Reset Dominant Bistable Instructions	72
	Clock Instructions	73
	Communications Instructions	74
	Network Read and Network Write Instructions	74
	Transmit and Receive Instructions (Freeport)	79
	Get Port Address and Set Port Address Instructions	88
	Compare Instructions	89
	Comparing Numerical Values	89
	Compare String	91
	Conversion Instructions	92
	Standard Conversion Instructions	92
	ASCII Conversion Instructions	96
	String Conversion Instructions	100
	Encode and Decode Instructions	105
	Counter Instructions	106
	SIMATIC Counter Instructions	106
	IEC Counter Instructions	109
	High-Speed Counter Instructions	111
	Pulse Output Instruction	125
	Math Instructions	140
	Add, Subtract, Multiply, and Divide Instructions	140
	Multiply Integer to Double Integer and Divide Integer with Remainder	142
	Numeric Functions Instructions	143
	Increment and Decrement Instructions	144
	Proportional/Integral/Derivative (PID) Loop Instruction	145
	Interrupt Instructions	155
	Logical Operations Instructions	162
	Invert Instructions	162
	AND, OR, and Exclusive OR Instructions	163
	Move Instructions	165
	Move Byte, Word, Double Word, or Real	165
	Move Byte Immediate (Read and Write)	166
	Block Move Instructions	167
	Program Control Instructions	168
	Conditional End	168
	Stop	168
	Watchdog Reset	168
	For-Next Loop Instructions	170
	Jump Instructions	172
	Sequence Control Relay (SCR) Instructions	173

Shift and Rotate Instructions	179
Shift Right and Shift Left Instructions	179
Rotate Right and Rotate Left Instructions	179
Shift Register Bit Instruction	181
Swap Bytes Instruction	183
String Instructions	184
Table Instructions	189
Add To Table	189
First-In-First-Out and Last-In-First-Out	190
Memory Fill	192
Table Find	193
Timer Instructions	196
SIMATIC Timer Instructions	196
IEC Timer Instructions	201
Subroutine Instructions	203
7 Communicating over a Network	207
Understanding the Basics of S7-200 Network Communications	208
Selecting the Communications Protocol for Your Network	211
Installing and Removing Communications Interfaces	216
Building Your Network	218
Creating User-Defined Protocols with Freeport Mode	222
Using Modems and STEP 7-Micro/WIN with Your Network	224
Advanced Topics	228
8 Hardware Troubleshooting Guide and Software Debugging Tools	235
Features for Debugging Your Program	236
Displaying the Program Status	238
Using a Status Chart to Monitor and Modify the Data in the S7-200	239
Forcing Specific Values	240
Running Your Program for a Specified Number of Scans	240
Hardware Troubleshooting Guide	241
9 Creating a Program for the Position Module	243
Features of the Position Module	244
Configuring the Position Module	246
Position Instructions Created by the Motion Control Wizard	257
Sample Programs for the Position Module	269
Monitoring the Position Module with the EM 253 Control Panel	274
Error Codes for the Position Module and the Position Instructions	276
Advanced Topics	278

10	Creating a Program for the Modem Module	287
	Features of the Modem Module	288
	Using the Modem Expansion Wizard to Configure the Modem Module	294
	Overview of Modem Instructions and Restrictions	298
	Instructions for the Modem Module	299
	Sample Program for the Modem Module	303
	S7-200 CPUs that Support Intelligent Modules	303
	Special Memory Location for the Modem Module	304
	Advanced Topics	306
	Messaging Telephone Number Format	308
	Text Message Format	309
	CPU Data Transfer Message Format	310
11	Using the USS Protocol Library to Control a MicroMaster Drive	311
	Requirements for Using the USS Protocol	312
	Calculating the Time Required for Communicating with the Drive	313
	Using the USS Instructions	314
	Instructions for the USS Protocol	315
	Sample Programs for the USS Protocol	322
	USS Execution Error Codes	323
	Connecting and Setting Up the MicroMaster Series 3 Drive	324
	Connecting and Setting Up the MicroMaster Series 4 Drive	327
12	Using the Modbus Protocol Library	329
	Requirements for Using the Modbus Protocol	330
	Initialization and Execution Time for the Modbus Protocol	330
	Modbus Addressing	331
	Using the Modbus Slave Protocol Instructions	332
	Instructions for the Modbus Slave Protocol	333
A	Technical Specifications	337
	General Technical Specifications	338
	CPU Specifications	340
	Digital Expansion Modules Specifications	346
	Analog Expansion Modules Specifications	351
	Thermocouple and RTD Expansion Modules Specifications	361
	EM 277 PROFIBUS-DP Module Specifications	373
	EM 241 Modem Module Specifications	385
	EM 253 Position Module Specifications	387
	AS-Interface (CP 243-2) Module Specifications	393
	Optional Cartridges	395
	I/O Expansion Cable	395
	PC/PPI Cable	396
	Input Simulators	398
B	Calculating a Power Budget	399

C	Error Codes	403
	Fatal Error Codes and Messages	404
	Run-Time Programming Problems	405
	Compile Rule Violations	406
D	Special Memory (SM) Bits	407
	SMB0: Status Bits	408
	SMB1: Status Bits	408
	SMB2: Freeport Receive Character	409
	SMB3: Freeport Parity Error	409
	SMB4: Queue Overflow	409
	SMB5: I/O Status	410
	SMB6: CPU ID Register	410
	SMB7: Reserved	410
	SMB8 to SMB21: I/O Module ID and Error Registers	411
	SMW22 to SMW26: Scan Times	412
	SMB28 and SMB29: Analog Adjustment	412
	SMB30 and SMB130: Freeport Control Registers	412
	SMB31 and SMW32: Permanent Memory (EEPROM) Write Control	413
	SMB34 and SMB35: Time Interval Registers for Timed Interrupts	413
	SMB36 to SMB65: HSC0, HSC1, and HSC2 Register	413
	SMB66 to SMB85: PTO/PWM Registers	415
	SMB86 to SMB94, and SMB186 to SMB194: Receive Message Control	416
	SMW98: Errors on the Expansion I/O Bus	417
	SMB130: Freeport Control Register (see SMB30)	417
	SMB131 to SMB165: HSC3, HSC4, and HSC5 Register	417
	SMB166 to SMB185: PTO0, PTO1 Profile Definition Table	418
	SMB186 to SMB194: Receive Message Control (see SMB86 to SMB94)	418
	SMB200 to SMB549: Intelligent Module Status	419
E	S7-200 Order Numbers	421
F	Execution Times for STL Instructions	425
G	S7-200 Quick Reference Information	431
	Index	437

Product Overview



The S7-200 series of micro-programmable logic controllers (Micro PLCs) can control a wide variety of devices to support your automation needs.

The S7-200 monitors inputs and changes outputs as controlled by the user program, which can include Boolean logic, counting, timing, complex math operations, and communications with other intelligent devices. The compact design, flexible configuration, and powerful instruction set combine to make the S7-200 a perfect solution for controlling a wide variety of applications.

In This Chapter

S7-200 CPU	2
S7-200 Expansion Modules	3
STEP 7–Micro/WIN Programming Package	3
Communications Options	4
Display Panels	4

S7-200 CPU

The S7-200 CPU combines a microprocessor, an integrated power supply, input circuits, and output circuits in a compact housing to create a powerful Micro PLC. See Figure 1-1. After you have downloaded your program, the S7-200 contains the logic required to monitor and control the input and output devices in your application.

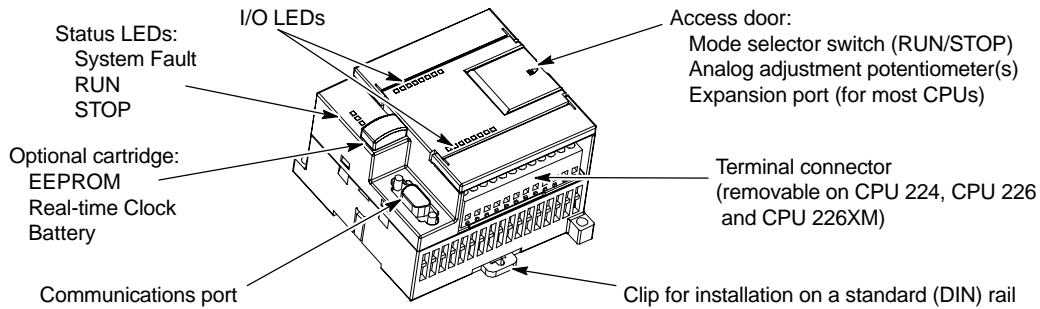

Figure 1-1 S7-200 Micro PLC

Siemens provides different S7-200 CPU models with a diversity of features and capabilities that help you create effective solutions for your varied applications. Table 1-1 briefly compares some of the features of the CPU. For detailed information about a specific CPU, see Appendix A.

Table 1-1 Comparison of the S7-200 CPU Models

Feature	CPU 221	CPU 222	CPU 224	CPU 226	CPU 226XM
Physical size (mm)	90 x 80 x 62	90 x 80 x 62	120.5 x 80 x 62	190 x 80 x 62	190 x 80 x 62
Program memory	2048 words	2048 words	4096 words	4096 words	8192 words
Data memory	1024 words	1024 words	2560 words	2560 words	5120 words
Memory backup	50 hours typical	50 hours typical	190 hours typical	190 hours typical	190 hours typical
Local on-board I/O	6 In/4 Out	8 In/6 Out	14 In/10 Out	24 In/16 Out	24 In/16 Out
Expansion modules	0	2	7	7	7
High-speed counters					
Single phase	4 at 30 kHz	4 at 30 kHz	6 at 30 kHz	6 at 30 kHz	6 at 30 kHz
Two phase	2 at 20 kHz	2 at 20 kHz	4 at 20 kHz	4 at 20 kHz	4 at 20 kHz
Pulse outputs (DC)	2 at 20 kHz	2 at 20 kHz	2 at 20 kHz	2 at 20 kHz	2 at 20 kHz
Analog adjustments	1	1	2	2	2
Real-time clock	Cartridge	Cartridge	Built-in	Built-in	Built-in
Communications ports	1 RS-485	1 RS-485	1 RS-485	2 RS-485	2 RS-485
Floating-point math	Yes				
Digital I/O image size	256 (128 in, 128 out)				
Boolean execution speed	0.37 microseconds/instruction				

S7-200 Expansion Modules

To better solve your application requirements, the S7-200 family includes a wide variety of expansion modules. You can use these expansion modules to add additional functionality to the S7-200 CPU. Table 1-2 provides a list of the expansion modules that are currently available. For detailed information about a specific module, see Appendix A.

Table 1-2 S7-200 Expansion Modules

Expansion Modules		Types		
Discrete modules	Input	8 x DC In	8 x AC In	
	Output	8 x DC Out	8 x AC Out	8 x Relay
	Combination	4 x DC In / 4 x DC Out 4 x DC In / 4 x Relay	8 x DC In / 8 x DC Out 8 x DC In / 8 x Relay	16 x DC In / 16 x DC Out 16 x DC In / 16 x Relay
Analog modules	Input	4 x Analog In	4 x Thermocouple In	2 x RTD In
	Output	2 x Analog Out		
	Combination	4 x Analog In / 1 Analog Out		
Intelligent modules		Position	Modem	PROFIBUS-DP
Other modules		AS-Interface		

STEP 7-Micro/WIN Programming Package

The STEP 7-Micro/WIN programming package provides a user-friendly environment to develop, edit, and monitor the logic needed to control your application. STEP 7-Micro/WIN provides three program editors for convenience and efficiency in developing the control program for your application. To help you find the information you need, STEP 7-Micro/WIN provides an extensive online help system and a documentation CD that contains an electronic version of this manual, application tips, and other useful information.

Computer Requirements

STEP 7-Micro/WIN runs on either a personal computer or a Siemens programming device, such as a PG 760. Your computer or programming device should meet the following minimum requirements:

- Operating system:
Windows 95, Windows 98, Windows 2000,
Windows Me (Millennium Edition), or
Windows NT 4.0 (or later version)
- At least 50M bytes of free hard disk space
- Mouse (recommended)

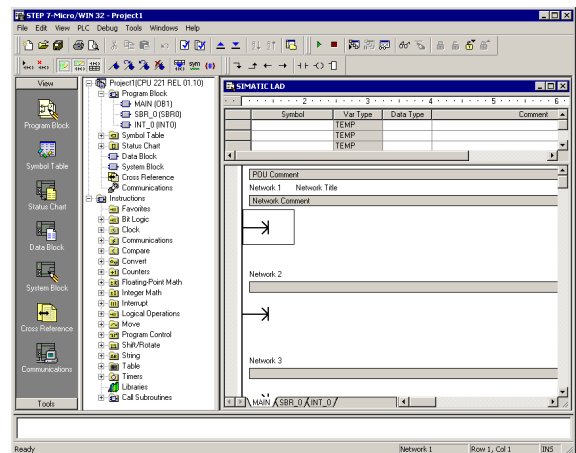

Figure 1-2 STEP 7-Micro/WIN

Installing STEP 7–Micro/WIN

Insert the STEP 7–Micro/WIN CD into the CD-ROM drive of your computer. The installation wizard starts automatically and prompts you through the installation process. Refer to the Readme file for more information about installing STEP 7–Micro/WIN.



Tip

To install STEP 7–Micro/WIN on a Windows NT or Windows 2000 operating system, you must log in with Administrator privileges.

Communications Options

Siemens provides two programming options for connecting your computer to your S7-200: a direct connection with a PC/PPI cable, or a Communications Processor (CP) card with an MPI cable for MPI and PROFIBUS–DP networks.

The PC/PPI programming cable is the most common and economical method of connecting your computer to the S7-200. This cable connects the communications port of the S7-200 to the serial communications of your computer. The PC/PPI programming cable can also be used to connect other communications devices to the S7-200.

To use the MPI cable, you must also install a CP card in your computer. The CP card provides the extra hardware required to connect at higher baud rates and to handle high-speed network communications.

Display Panels

TD 200 Text Display Unit

The TD 200 is a 2-line, 20-character, text display device that can be connected to the S7-200. Using the TD 200 wizard, you can easily program your S7-200 to display text messages and other data pertaining to your application.

The TD 200 provides a low cost interface to your application by allowing you to view, monitor, and change the process variables pertaining to your application.

A separate manual describes the detailed functionality and specifications of the TD 200.

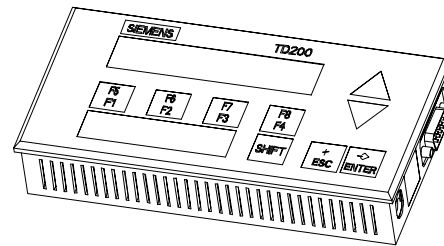

Figure 1-3 TD 200 Text Display Unit

TP070 Touch Panel Display

The TP070 is a touch panel display device that can be connected to the S7-200. This touch panel provides you with a means to customize your operator interface.

The TP070 can display custom graphics, slider bars, application variables, custom user buttons, and so forth, by means of a user-friendly touch panel.

The optional TP–Designer for TP070, Version 1.0 CD provides the TP Designer software, which is required for programming your TP070.

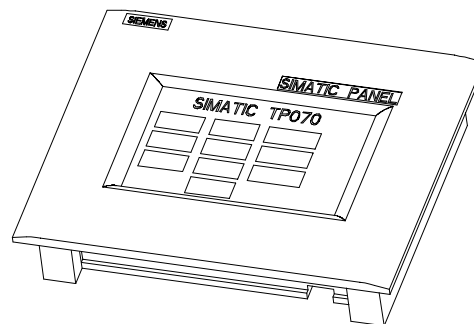

Figure 1-4 TP070 Touch Panel Unit

Getting Started



STEP 7–Micro/WIN makes it easy for you to program your S7-200. In just a few short steps using a simple example, you can learn how to connect, program, and run your S7-200.

All you need for this example is a PC/PPI cable, an S7-200 CPU, and a programming device running the STEP 7–Micro/WIN programming software.

In This Chapter

Connecting the S7-200 CPU	6
Creating a Sample Program	8
Downloading the Sample Program	11
Placing the S7-200 in RUN Mode	11

Connecting the S7-200 CPU

Connecting your S7-200 is easy. For this example, you only need to connect power to your S7-200 CPU and then connect the communications cable between your programming device and the S7-200 CPU.

Connecting Power to the S7-200 CPU

The first step is to connect the S7-200 to a power source. Figure 2-1 shows the wiring connections for either a DC or an AC model of the S7-200 CPU.

Before you install or remove any electrical device, ensure that the power to that equipment has been turned off. Always follow appropriate safety precautions and ensure that power to the S7-200 is disabled before attempting to install or remove the S7-200.



Warning

Attempts to install or wire the S7-200 or related equipment with power applied could cause electric shock or faulty operation of equipment. Failure to disable all power to the S7-200 and related equipment during installation or removal procedures could result in death or serious injury to personnel, and/or damage to equipment.

Always follow appropriate safety precautions and ensure that power to the S7-200 is disabled before attempting to install or remove the S7-200 or related equipment.

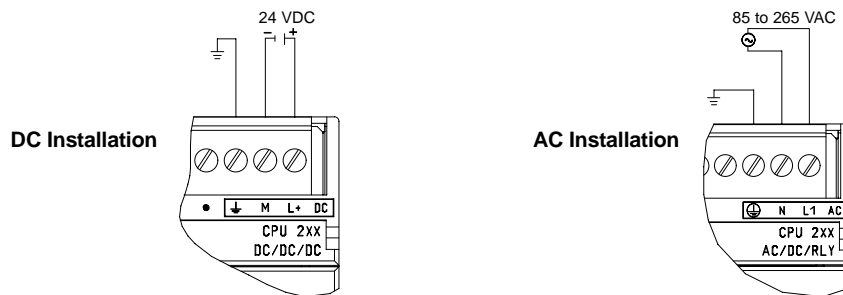

Figure 2-1 Connecting Power to the S7-200 CPU

Connecting the PC/PPI Cable

Figure 2-2 shows a PC/PPI cable connecting the S7-200 to the programming device. To connect the PC/PPI cable:

1. Connect the RS-232 connector (marked "PC") of the PC/PPI cable to the communications port of the programming device. (For this example, connect to COM 1.)
2. Connect the RS-485 connector (marked "PPI") of the PC/PPI cable to Port 0 or Port 1 of the S7-200.
3. Ensure that the dipswitches of the PC/PPI cable are set as shown in Figure 2-2.

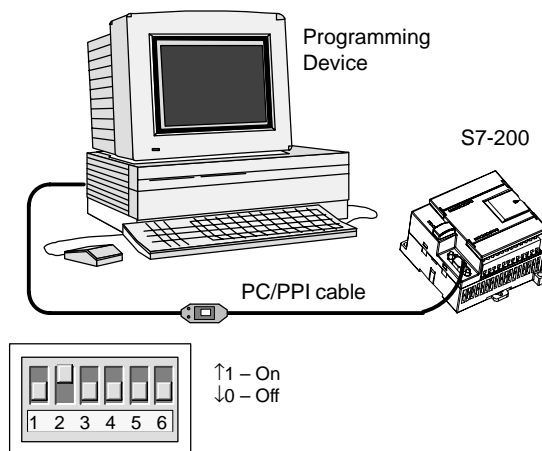

Figure 2-2 Connecting the PC/PPI Cable

Starting STEP 7–Micro/WIN

Click on the STEP 7–Micro/WIN icon to open a new project. Figure 2-3 shows a new project.

Notice the navigation bar. You can use the icons on the navigation bar to open elements of the STEP 7–Micro/WIN project.

Click on the Communications icon in the navigation bar to display the Communications dialog box. You use this dialog box to set up the communications for STEP 7–Micro/WIN.

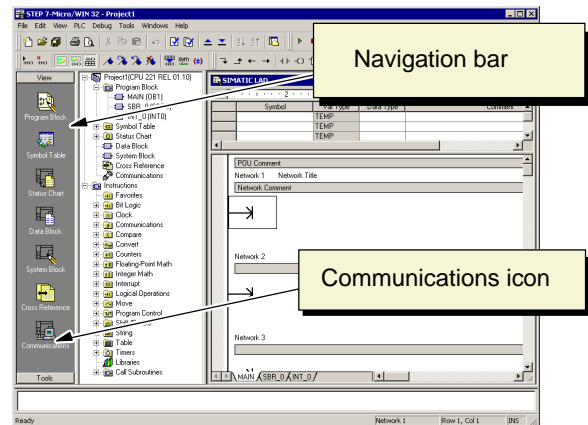

Figure 2-3 New STEP 7–Micro/WIN Project

Verifying the Communications Parameters for STEP 7–Micro/WIN

The example project uses the default settings for STEP 7–Micro/WIN and the PC/PPI cable. To verify these settings:

1. Verify that the address of the PC/PPI cable in the Communications dialog box is set to 0.
2. Verify that the interface for the network parameter is set for PC/PPI cable(COM1).
3. Verify that the transmission rate is set to 9.6 kbps.

If you need to change your communications parameter settings, see Chapter 7.

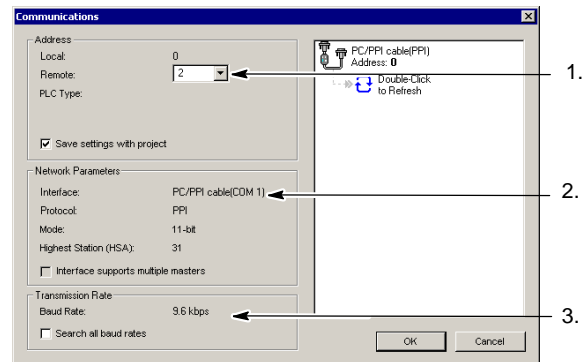

Figure 2-4 Verifying the Communications Parameters

Establishing Communications with the S7-200

Use the Communications dialog box to connect with your S7-200 CPU:

1. Double-click the refresh icon in the Communications dialog box.
STEP 7–Micro/WIN searches for the S7-200 station and displays a CPU icon for the connected S7-200 station.
2. Select the S7-200 and click OK.

If STEP 7–Micro/WIN does not find your S7-200 CPU, check the settings for the communications parameters and repeat these steps.

After you have established communications with the S7-200, you are ready to create and download the example program.

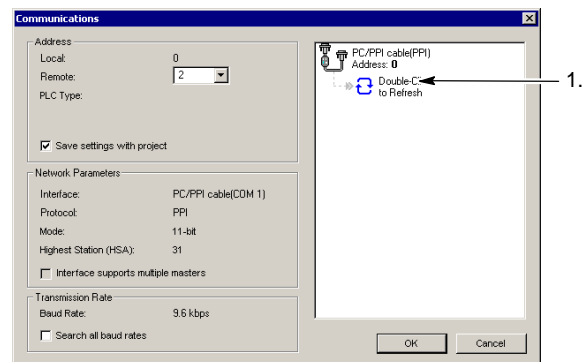
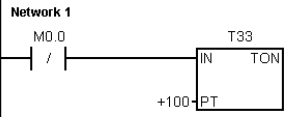
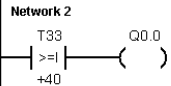
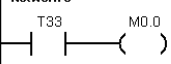
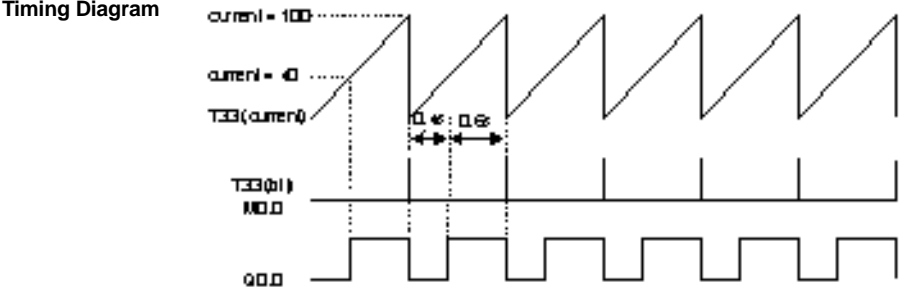

Figure 2-5 Establishing Communications to the S7-200

Creating a Sample Program

Entering this example of a control program will help you understand how easy it is to use STEP 7–Micro/WIN. This program uses six instructions in three networks to create a very simple, self-starting timer that resets itself.

For this example, you use the Ladder (LAD) editor to enter the instructions for the program. The following example shows the complete program in both LAD and Statement List (STL). The network comments in the STL program explain the logic for each network. The timing diagram shows the operation of the program.

Example: Sample Program for getting started with STEP 7–Micro/WIN	
<p>Network 1</p>  <p>Network 2</p>  <p>Network 3</p> 	<pre> Network 1 //10 ms timer T33 times out after (100 x 10 ms = 1 s) //M0.0 pulse is too fast to monitor with Status view. LDN M0.0 TON T33, +100 Network 2 //Comparison becomes true at a rate that is visible with //Status view. Turn on Q0.0 after (40 x 10 ms = 0.4 s), //for a 40% OFF/60% ON waveform. LDW>= T33, +40 = Q0.0 Network 3 //T33 (bit) pulse too fast to monitor with Status view. //Reset the timer through M0.0 after the //(100 x 10 ms = 1 s) period. LD T33 = M0.0 </pre>
<p>Timing Diagram</p> 	

Opening the Program Editor

Click on the Program Block icon to open the program editor. See Figure 2-6.

Notice the instruction tree and the program editor. You use the instruction tree to insert the LAD instructions into the networks of the program editor by dragging and dropping the instructions from the instruction tree to the networks.

The toolbar icons provide shortcuts to the menu commands.

After you enter and save the program, you can download the program to the S7-200.

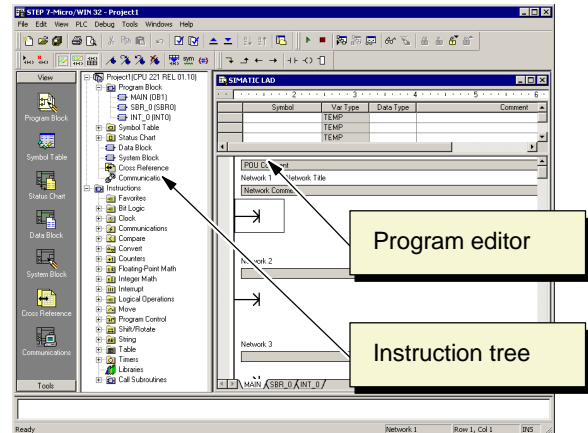

Figure 2-6 STEP 7-Micro/WIN Window

Entering Network 1: Starting the Timer

When M0.0 is off (0), this contact turns on and provides power flow to start the timer. To enter the contact for M0.0:

1. Either double-click the Bit Logic icon or click on the plus sign (+) to display the bit logic instructions.
2. Select the Normally Closed contact.
3. Hold down the left mouse button and drag the contact onto the first network.
4. Click on the “???” above the contact and enter the following address: M0.0
5. Press the Return key to enter the address for the contact.

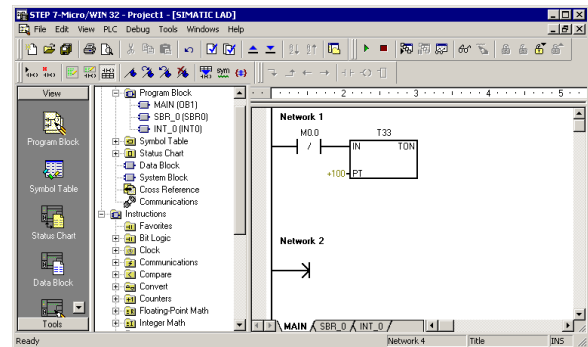

Figure 2-7 Network 1

To enter the timer instruction for T33:

1. Double-click the Timers icon to display the timer instructions.
2. Select the TON (On-Delay Timer).
3. Hold down the left mouse button and drag the timer onto the first network.
4. Click on the “???” above the timer box and enter the following timer number: T33
5. Press the Return key to enter the timer number and to move the focus to the preset time (PT) parameter.
6. Enter the following value for the preset time: 100
7. Press the Return key to enter the value.

Entering Network 2: Turning the Output On

When the timer value for T33 is greater than or equal to 40 (40 times 10 milliseconds, or 0.4 seconds), the contact provides power flow to turn on output Q0.0 of the S7-200. To enter the Compare instruction:

1. Double-click the Compare icon to display the compare instructions. Select the $\geq I$ instruction (Greater-Than-Or-Equal-To-Integer).
2. Hold down the left mouse button and drag the compare instruction onto the second network.
3. Click on the “???” above the contact and enter the address for the timer value: T33
4. Press the Return key to enter the timer number and to move the focus to the other value to be compared with the timer value.
5. Enter the following value to be compared with the timer value: 40
6. Press the Return key to enter the value.

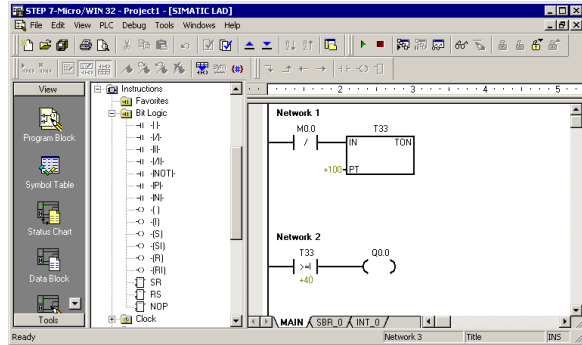

Figure 2-8 Network 2

To enter the instruction for turning on output Q0.0:

1. Double-click the Bit Logic icon to display the bit logic instructions and select the output coil.
2. Hold down the left mouse button and drag the coil onto the second network.
3. Click on the “???” above the coil and enter the following address: Q0.0
4. Press the Return key to enter the address for the coil.

Entering Network 3: Resetting the Timer

When the timer reaches the preset value (100) and turns the timer bit on, the contact for T33 turns on. Power flow from this contact turns on the M0.0 memory location. Because the timer is enabled by a Normally Closed contact for M0.0, changing the state of M0.0 from off (0) to on (1) resets the timer.

To enter the contact for the timer bit of T33:

1. Select the Normally Open contact from the bit logic instructions.
2. Hold down the left mouse button and drag the contact onto the third network.
3. Click on the “???” above the contact and enter the address of the timer bit: T33
4. Press the Return key to enter the address for the contact.

To enter the coil for turning on M0.0:

1. Select the output coil from the bit logic instructions.
2. Hold down the left mouse button and drag the output coil onto the third network.
3. Double-click the “???” above the coil and enter the following address: M0.0
4. Press the Return key to enter the address for the coil.

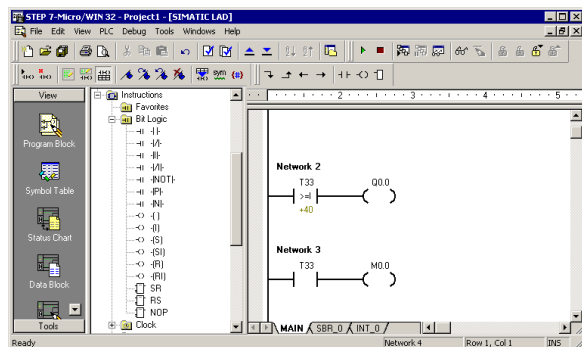

Figure 2-9 Network 3

Saving the Sample Project

After entering the three networks of instructions, you have finished entering the program. When you save the program, you create a project that includes the S7-200 CPU type and other parameters. To save the project:

1. Select the **File > Save As** menu command from the menu bar.
2. Enter a name for the project in the Save As dialog box.
3. Click OK to save the project.

After saving the project, you can download the program to the S7-200.

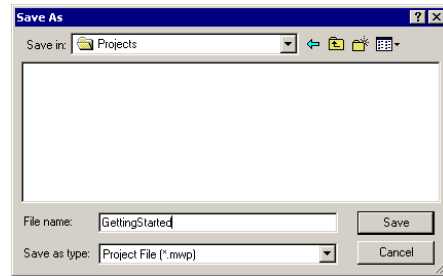

Figure 2-10 Saving the Example Program

Downloading the Sample Program



Tip

Each STEP 7–Micro/WIN project is associated with a CPU type (CPU 221, CPU 222, CPU 224, CPU 226, or CPU 226XM). If the project type does not match the CPU to which you are connected, STEP 7–Micro/WIN indicates a mismatch and prompts you to take an action. If this occurs, choose “Continue Download” for this example.

1. Click the Download icon on the toolbar or select the **File > Download** menu command to download the program. See Figure 2-11.
2. Click OK to download the elements of the program to the S7-200.

If your S7-200 is in RUN mode, a dialog box prompts you to place the S7-200 in STOP mode. Click Yes to place the S7-200 into STOP mode.

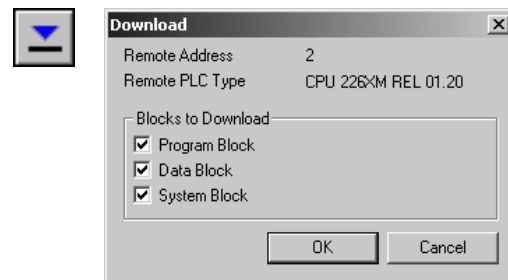

Figure 2-11 Downloading the Program

Placing the S7-200 in RUN Mode

For STEP 7–Micro/WIN to place the S7-200 CPU in RUN mode, the mode switch of the S7-200 must be set to TERM or RUN. When you place the S7-200 in RUN mode, the S7-200 executes the program:

1. Click the RUN icon on the toolbar or select the **PLC > RUN** menu command.
2. Click OK to change the operating mode of the S7-200.

When the S7-200 goes to RUN mode, the output LED for Q0.0 turns on and off as the S7-200 executes the program.

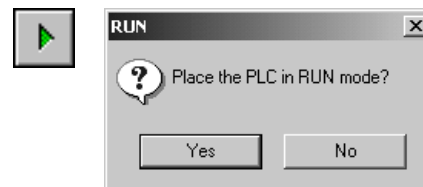

Figure 2-12 Placing the S7-200 in RUN Mode

Congratulations! You have just completed your first S7-200 program.

You can monitor the program by selecting the **Debug > Program Status** menu command. STEP 7–Micro/WIN displays the values for the instructions. To stop the program, place the S7-200 in STOP mode by clicking the STOP icon or by selecting the **PLC > STOP** menu command.

3

Installing the S7-200

The S7-200 equipment is designed to be easy to install. You can use the mounting holes to attach the modules to a panel, or you can use the built-in clips to mount the modules onto a standard (DIN) rail. The small size of the S7-200 allows you to make efficient use of space.

This chapter provides guidelines for installing and wiring your S7-200 system.

In This Chapter

Guidelines for Installing S7-200 Devices	14
Installing and Removing the S7-200 Modules	15
Guidelines for Grounding and Wiring	18

Guidelines for Installing S7-200 Devices

You can install an S7-200 either on a panel or on a standard rail, and you can orient the S7-200 either horizontally or vertically.

Separate the S7-200 Devices from Heat, High Voltage, and Electrical Noise

As a general rule for laying out the devices of your system, always separate the devices that generate high voltage and high electrical noise from the low-voltage, logic-type devices such as the S7-200.

When configuring the layout of the S7-200 inside your panel, consider the heat-generating devices and locate the electronic-type devices in the cooler areas of your cabinet. Operating any electronic device in a high-temperature environment will reduce the time to failure.

Consider also the routing of the wiring for the devices in the panel. Avoid placing low voltage signal wires and communications cables in the same tray with AC power wiring and high-energy, rapidly-switched DC wiring.

Provide Adequate Clearance for Cooling and Wiring

S7-200 devices are designed for natural convection cooling. For proper cooling, you must provide a clearance of at least 25 mm above and below the devices. Also, allow at least 75 mm of depth.



Tip

For vertical mounting, the maximum allowable ambient temperature is reduced by 10° C. Mount the S7-200 CPU below any expansion modules.

When planning your layout for the S7-200 system, allow enough clearance for the wiring and communications cable connections. For additional flexibility in configuring the layout of the S7-200 system, use the I/O expansion cable.

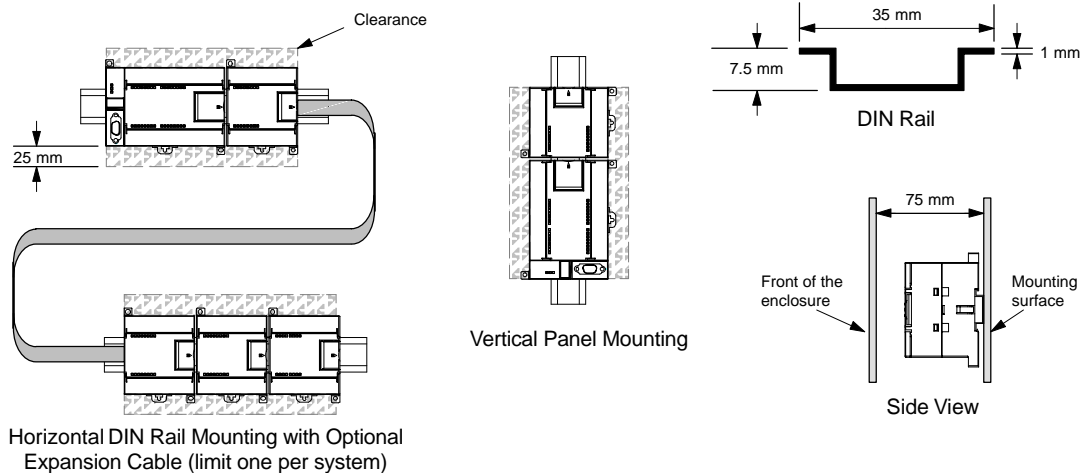

Figure 3-1 Mounting Methods, Orientation, and Clearance

Power Budget

All S7-200 CPUs have an internal power supply that provides power for the CPU, the expansion modules, and other 24 VDC user power requirements.

The S7-200 CPU provides the 5 VDC logic power needed for any expansion in your system. Pay careful attention to your system configuration to ensure that your CPU can supply the 5V power required by your selected expansion modules. If your configuration requires more power than the CPU can supply, you must remove a module or select a CPU with more power capability. Refer to Appendix A for information about the 5 VDC logic budget supplied by your S7-200 CPU and the 5 VDC power requirements of the expansion modules. Use Appendix B as a guide for determining how much power (or current) the CPU can provide for your configuration.

All S7-200 CPUs also provide a 24 VDC sensor supply that can supply 24 VDC for input points, for relay coil power on the expansion modules, or for other requirements. If your power requirements exceed the budget of the sensor supply, then you must add an external 24 VDC power supply to your system. Refer to Appendix A for the 24 VDC sensor supply power budget for your particular S7-200 CPU.

If you require an external 24 VDC power supply, ensure that the power supply is not connected in parallel with the sensor supply of the S7-200 CPU. For improved electrical noise protection, it is recommended that the commons (M) of the different power supplies be connected.



Warning

Connecting an external 24 VDC power supply in parallel with the S7-200 24 VDC sensor supply can result in a conflict between the two supplies as each seeks to establish its own preferred output voltage level.

The result of this conflict can be shortened lifetime or immediate failure of one or both power supplies, with consequent unpredictable operation of the PLC system. Unpredictable operation could result in death or serious injury to personnel, and/or damage to equipment.

The S7-200 DC sensor supply and any external power supply should provide power to different points.

Installing and Removing the S7-200 Modules

The S7-200 can be easily installed on a standard DIN rail or on a panel.

Prerequisites

Before you install or remove any electrical device, ensure that the power to that equipment has been turned off. Also, ensure that the power to any related equipment has been turned off.



Warning

Attempts to install or remove S7-200 or related equipment with the power applied could cause electric shock or faulty operation of equipment.

Failure to disable all power to the S7-200 and related equipment during installation or removal procedures could result in death or serious injury to personnel, and/or damage to equipment.

Always follow appropriate safety precautions and ensure that power to the S7-200 is disabled before attempting to install or remove S7-200 CPUs or related equipment.

Always ensure that whenever you replace or install an S7-200 device you use the correct module or equivalent device.



Warning

If you install an incorrect module, the program in the S7-200 could function unpredictably.

Failure to replace an S7-200 device with the same model, orientation, or order could result in death or serious injury to personnel, and/or damage to equipment.

Replace an S7-200 device with the same model, and be sure to orient and position it correctly.

Mounting Dimensions

The S7-200 CPUs and expansion modules include mounting holes to facilitate installation on panels. Refer to Table 3-1 for the mounting dimensions.

Table 3-1 Mounting Dimensions

S7-200 Module	Width A	Width B
CPU 221 and CPU 222	90 mm	82 mm
CPU 224	120.5 mm	112.5 mm
CPU 226 and CPU 226XM	196 mm	188 mm
Expansion modules: 8-point DC and Relay I/O (8I, 8Q, 4I/4Q, 2 AQ)	46 mm	38 mm
Expansion modules: 16-point digital I/O (8I/8Q), Analog I/O (4AI, 4AQ/1AQ), RTD, Thermocouple, PROFIBUS, AS-Interface, 8-point AC (8I and 8Q), Position, and Modem	71.2 mm	63.2 mm
Expansion modules: 32-point digital I/O (16I/16Q)	137.3 mm	129.3 mm

Installing a CPU or Expansion Module

Installing the S7-200 is easy! Just follow these steps.

Panel Mounting

1. Locate, drill, and tap the mounting holes (M4 or American Standard number 8), using the dimensions in Table 3-1.
2. Secure the module(s) to the panel, using the appropriate screws.
3. If you are using an expansion module, connect the expansion module ribbon cable into the expansion port connector under the access door.

DIN Rail Mounting

1. Secure the rail to the mounting panel every 75 mm.
2. Snap open the DIN clip (located on the bottom of the module) and hook the back of the module onto the DIN rail.
3. If you are using an expansion module, connect the expansion module ribbon cable into the expansion port connector under the access door.
4. Rotate the module down to the DIN rail and snap the clip closed. Carefully check that the clip has fastened the module securely onto the rail. To avoid damage to the module, press on the tab of the mounting hole instead of pressing directly on the front of the module.

**Tip**

Using DIN rail stops could be helpful if your S7-200 is in an environment with high vibration potential or if the S7-200 has been installed vertically.

If your system is in a high-vibration environment, then panel-mounting the S7-200 will provide a greater level of vibration protection.

Removing a CPU or Expansion Module

To remove an S7-200 CPU or expansion module, follow these steps:

1. Remove power from the S7-200.
2. Disconnect all the wiring and cabling that is attached to the module. Most S7-200 CPU and expansion modules have removable connectors to make this job easier.
3. If you have expansion modules connected to the unit that you are removing, open the access cover door and disconnect the expansion module ribbon cable from the adjacent modules.
4. Unscrew the mounting screws or snap open the DIN clip.
5. Remove the module.

Removing and Reinstalling the Terminal Block Connector

Most S7-200 modules have removable connectors to make installing and replacing the module easy. Refer to Appendix A to determine whether your S7-200 module has removable connectors. You can order an optional fan-out connector for modules that do not have removable connectors. See Appendix E for order numbers.

To Remove the Connector

1. Open the connector door to gain access to the connector.
2. Insert a small screwdriver in the notch in the middle of the connector.
3. Remove the terminal connector by prying the screwdriver away from the S7-200 housing. See Figure 3-2.

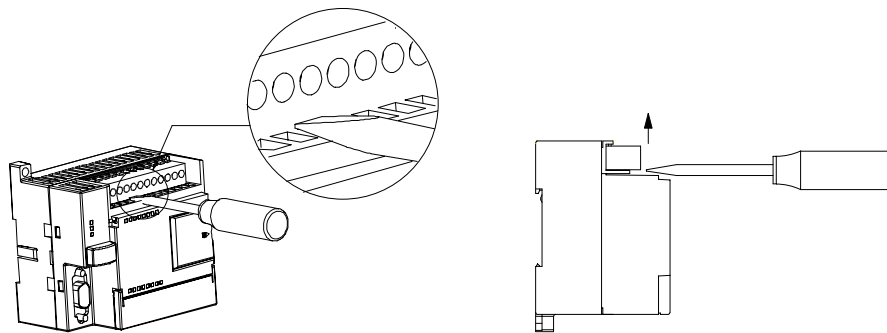

Figure 3-2 Removing the Connector

To Reinstall the Connector

1. Open the connector door.
2. Align the connector with the pins on the unit and align the wiring edge of the connector inside the rim of the connector base.
3. Press down firmly to rotate the connector until it snaps into place. Check carefully to ensure that the connector is properly aligned and fully engaged.

Guidelines for Grounding and Wiring

Proper grounding and wiring of all electrical equipment is important to help ensure the optimum operation of your system and to provide additional electrical noise protection for your application and the S7-200.

Prerequisites

3

Before you ground or install wiring to any electrical device, ensure that the power to that equipment has been turned off. Also, ensure that the power to any related equipment has been turned off.

Ensure that you follow all applicable electrical codes when wiring the S7-200 and related equipment. Install and operate all equipment according to all applicable national and local standards. Contact your local authorities to determine which codes and standards apply to your specific case.

**Warning**

Attempts to install or wire the S7-200 or related equipment with power applied could cause electric shock or faulty operation of equipment. Failure to disable all power to the S7-200 and related equipment during installation or removal procedures could result in death or serious injury to personnel, and/or damage to equipment.

Always follow appropriate safety precautions and ensure that power to the S7-200 is disabled before attempting to install or remove the S7-200 or related equipment.

Always take safety into consideration as you design the grounding and wiring of your S7-200 system. Electronic control devices, such as the S7-200, can fail and can cause unexpected operation of the equipment that is being controlled or monitored. For this reason, you should implement safeguards that are independent of the S7-200 to protect against possible personal injury or equipment damage.

**Warning**

Control devices can fail in an unsafe condition, resulting in unexpected operation of controlled equipment. Such unexpected operations could result in death or serious injury to personnel, and/or damage to equipment.

Use an emergency stop function, electromechanical overrides, or other redundant safeguards that are independent of the S7-200.

Guidelines for Isolation

S7-200 AC power supply boundaries and I/O boundaries to AC circuits are rated 1500 VAC. These isolation boundaries have been examined and approved as providing safe separation between AC line and low voltage circuits.

All low voltage circuits connected to an S7-200, such as 24V power, must be supplied from an approved source that provides safe isolation from AC line and other high voltages. Such sources include double insulation as defined in international electrical safety standards and have outputs that are rated as SELV, PELV, Class 2, or Limited Voltage according to various standards.

**Warning**

Use of non-isolated or single insulation supplies to supply low voltage circuits from an AC line can result in hazardous voltages appearing on circuits that are expected to be touch safe, such as communications circuits and low voltage sensor wiring.

Such unexpected high voltages could result in death or serious injury to personnel, and/or damage to equipment.

Only use high voltage to low voltage power converters that are approved as sources of touch safe, limited voltage circuits.

Guidelines for Grounding the S7-200

The best way to ground your application is to ensure that all the common connections of your S7-200 and related equipment are grounded to a single point. This single point should be connected directly to the earth ground for your system.

For improved electrical noise protection, it is recommended that all DC common returns be connected to the same single-point earth ground. Connect the 24 VDC sensor supply common (M) to earth ground.

All ground wires should be as short as possible and should use a large wire size, such as 2 mm² (14 AWG).

When locating grounds, remember to consider safety grounding requirements and the proper operation of protective interrupting devices.

Guidelines for Wiring the S7-200

When designing the wiring for your S7-200, provide a single disconnect switch that simultaneously removes power from the S7-200 CPU power supply, from all input circuits, and from all output circuits. Provide overcurrent protection, such as a fuse or circuit breaker, to limit fault currents on supply wiring. You might want to provide additional protection by placing a fuse or other current limit in each output circuit.

Install appropriate surge suppression devices for any wiring that could be subject to lightning surges.

Avoid placing low-voltage signal wires and communications cables in the same wire tray with AC wires and high-energy, rapidly switched DC wires. Always route wires in pairs, with the neutral or common wire paired with the hot or signal-carrying wire.

Use the shortest wire possible and ensure that the wire is sized properly to carry the required current. The connector accepts wire sizes from 2 mm² to 0.3 mm² (14 AWG to 22 AWG). Use shielded wires for optimum protection against electrical noise. Typically, grounding the shield at the S7-200 gives the best results.

When wiring input circuits that are powered by an external power supply, include an overcurrent protection device in that circuit. External protection is not necessary for circuits that are powered by the 24 VDC sensor supply from the S7-200 because the sensor supply is already current-limited.

Most S7-200 modules have removable connectors for user wiring. (Refer to Appendix A to determine if your module has removable connectors.) To prevent loose connections, ensure that the connector is seated securely and that the wire is installed securely into the connector. To avoid damaging the connector, be careful to not over-tighten the screws. The maximum torque for the connector screw is 0.56 N-m (5 inch-pounds).

To help prevent unwanted current flows in your installation, the S7-200 provides isolation boundaries at certain points. When you plan the wiring for your system, you should consider these isolation boundaries. Refer to Appendix A for the amount of isolation provided and the location of the isolation boundaries. Isolation boundaries rated less than 1500VAC must not be depended on as safety boundaries.



Tip

For a communications network, the maximum length of the communications cable is 50 m without using a repeater. The communications port on the S7-200 is non-isolated. Refer to Chapter 7 for more information.

Guidelines for Suppression Circuits

You should equip inductive loads with suppression circuits to limit voltage rise when the control output turns off. Suppression circuits protect your outputs from premature failure due to high inductive switching currents. In addition, suppression circuits limit the electrical noise generated when switching inductive loads.

3



Tip

The effectiveness of a given suppression circuit depends on the application, and you must verify it for your particular use. Always ensure that all components used in your suppression circuit are rated for use in the application.

DC Outputs and Relays That Control DC Loads

The DC outputs have internal protection that is adequate for most applications. Since the relays can be used for either a DC or an AC load, internal protection is not provided.

Figure 3-3 shows a sample suppression circuit for a DC load. In most applications, the addition of a diode (A) across the inductive load is suitable, but if your application requires faster turn-off times, then the addition of a Zener diode (B) is recommended. Be sure to size your Zener diode properly for the amount of current in your output circuit.

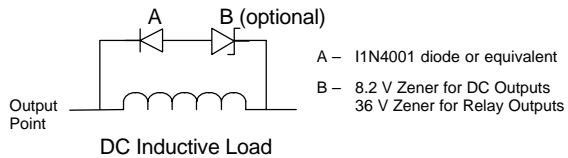

Figure 3-3 Suppression Circuit for a DC Load

AC Outputs and Relays That Control AC Loads

The AC outputs have internal protection that is adequate for most applications. Since the relays can be used for either a DC or an AC load, internal protection is not provided.

Figure 3-4 shows a sample suppression circuit for an AC load. In most applications, the addition of a metal oxide varistor (MOV) will limit the peak voltage and provide protection for the internal S7-200 circuits. Ensure that the working voltage of the MOV is at least 20% greater than the nominal line voltage.

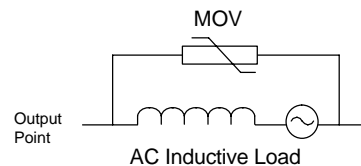

Figure 3-4 Suppression Circuit for a AC Load

PLC Concepts

4

The basic function of the S7-200 is to monitor field inputs and, based on your control logic, turn on or off field output devices. This chapter explains the concepts used to execute your program, the various types of memory used, and how that memory is retained.

In This Chapter

Understanding How the S7-200 Executes Your Control Logic	22
Accessing the Data of the S7-200	24
Understanding How the S7-200 Saves and Restores Data	34
Storing Your Program on a Memory Cartridge	36
Selecting the Operating Mode for the S7-200 CPU	37
Using Your Program to Save V Memory to the EEPROM	38
Features of the S7-200	39

Understanding How the S7-200 Executes Your Control Logic

The S7-200 continuously cycles through the control logic in your program, reading and writing data.

The S7-200 Relates Your Program to the Physical Inputs and Outputs

The basic operation of the S7-200 is very simple:

- ❑ The S7-200 reads the status of the inputs.
- ❑ The program that is stored in the S7-200 uses these inputs to evaluate the control logic. As the program runs, the S7-200 updates the data.
- ❑ The S7-200 writes the data to the outputs.

Figure 4-1 shows a simple diagram of how an electrical relay diagram relates to the S7-200. In this example, the state of the switch for starting the motor is combined with the states of other inputs. The calculations of these states then determine the state for the output that goes to the actuator which starts the motor.

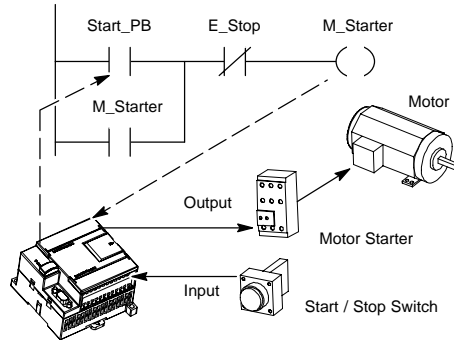

Figure 4-1 Controlling Inputs and Outputs

The S7-200 Executes Its Tasks in a Scan Cycle

The S7-200 executes a series of tasks repetitively. This cyclical execution of tasks is called the scan cycle. As shown in Figure 4-2, the S7-200 performs most or all of the following tasks during a scan cycle:

- ❑ Reading the inputs: The S7-200 copies the state of the physical inputs to the process-image input register.
- ❑ Executing the control logic in the program: The S7-200 executes the instructions of the program and stores the values in the various memory areas.
- ❑ Processing any communications requests: The S7-200 performs any tasks required for communications.
- ❑ Executing the CPU self-test diagnostics: The S7-200 ensures that the firmware, the program memory, and any expansion modules are working properly.
- ❑ Writing to the outputs: The values stored in the process-image output register are written to the physical outputs.

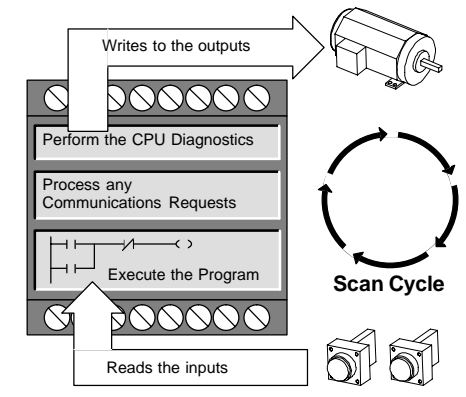

Figure 4-2 S7-200 Scan Cycle

The execution of the scan cycle is dependent upon whether the S7-200 is in STOP mode or in RUN mode. In RUN mode, your program is executed; in STOP mode, your program is not executed.

Reading the Inputs

Digital inputs: Each scan cycle begins by reading the current value of the digital inputs and then writing these values to the process-image input register.

Analog inputs: The S7-200 does not update analog inputs as part of the normal scan cycle unless filtering of analog inputs is enabled. An analog filter is provided to allow you to have a more stable signal. You can enable the analog filter for each analog input point.

When analog input filtering is enabled for an analog input, the S7-200 updates that analog input once per scan cycle, performs the filtering function, and stores the filtered value internally. The filtered value is then supplied each time your program accesses the analog input.

When analog filtering is not enabled, the S7-200 reads the value of the analog input from the physical module each time your program accesses the analog input.



Tip

Analog input filtering is provided to allow you to have a more stable analog value. Use the analog input filter for applications where the input signal varies slowly with time. If the signal is a high-speed signal, then you should not enable the analog filter.

Do not use the analog filter with modules that pass digital information or alarm indications in the analog words. Always disable analog filtering for RTD, Thermocouple, and AS-Interface Master modules.

Executing the Program

During the execution phase of the scan cycle, the S7-200 executes your program, starting with the first instruction and proceeding to the end instruction. The immediate I/O instructions give you immediate access to inputs and outputs during the execution of either the program or an interrupt routine.

If you use interrupts in your program, the interrupt routines that are associated with the interrupt events are stored as part of the program. The interrupt routines are not executed as part of the normal scan cycle, but are executed when the interrupt event occurs (which could be at any point in the scan cycle).

Processing Any Communications Requests

During the message-processing phase of the scan cycle, the S7-200 processes any messages that were received from the communications port or intelligent I/O modules.

Executing the CPU Self-test Diagnostics

During this phase of the scan cycle, the S7-200 checks for proper operation of the CPU, for memory areas, and for the status of any expansion modules.

Writing to the Digital Outputs

At the end of every scan cycle, the S7-200 writes the values stored in the process-image output register to the digital outputs. (Analog outputs are updated immediately, independently from the scan cycle.)

Accessing the Data of the S7-200

The S7-200 stores information in different memory locations that have unique addresses. You can explicitly identify the memory address that you want to access. This allows your program to have direct access to the information. Table 4-1 shows the range of integer values that can be represented by the different sizes of data.

Table 4-1 Decimal and Hexadecimal Ranges for the Different Sizes of Data

Representation	Byte (B)	Word (W)	Double Word (D)
Unsigned Integer	0 to 255 0 to FF	0 to 65,535 0 to FFFF	0 to 4,294,967,295 0 to FFFF FFFF
Signed Integer	-128 to +127 80 to 7F	-32,768 to +32,767 8000 to 7FFF	-2,147,483,648 to +2,147,483,647 8000 0000 to 7FFF FFFF
Real IEEE 32-bit Floating Point	<i>Not applicable</i>	<i>Not applicable</i>	+1.175495E-38 to +3.402823E+38 (positive) -1.175495E-38 to -3.402823E+38 (negative)

To access a bit in a memory area, you specify the address, which includes the memory area identifier, the byte address, and the bit number. Figure 4-3 shows an example of accessing a bit (which is also called “byte.bit” addressing). In this example, the memory area and byte address (I = input, and 3 = byte 3) are followed by a period (“.”) to separate the bit address (bit 4).

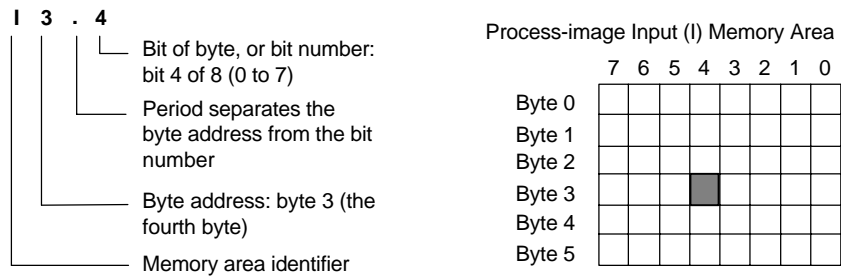

Figure 4-3 Byte.Bit Addressing

You can access data in most memory areas (V, I, Q, M, S, L, and SM) as bytes, words, or double words by using the byte-address format. To access a byte, word, or double word of data in the memory, you must specify the address in a way similar to specifying the address for a bit. This includes an area identifier, data size designation, and the starting byte address of the byte, word, or double-word value, as shown in Figure 4-4.

Data in other memory areas (such as T, C, HC, and the accumulators) are accessed by using an address format that includes an area identifier and a device number.

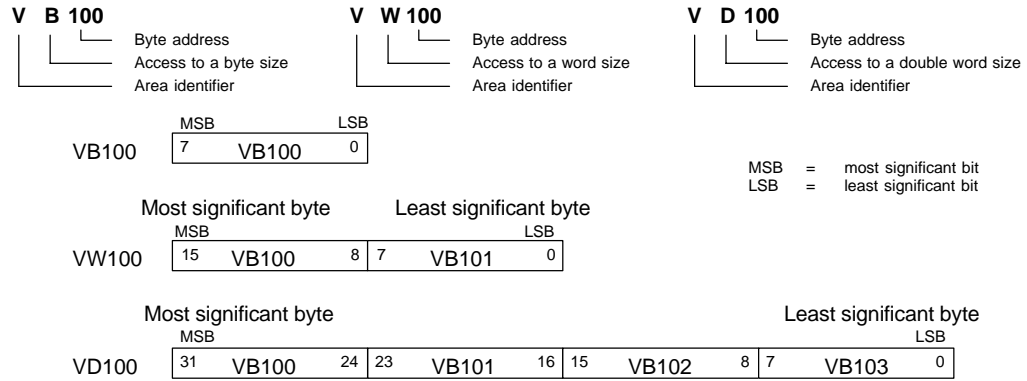

Figure 4-4 Comparing Byte, Word, and Double-Word Access to the Same Address

Accessing Data in the Memory Areas

Process-Image Input Register: I

The S7-200 samples the physical input points at the beginning of each scan cycle and writes these values to the process-image input register. You can access the process-image input register in bits, bytes, words, or double words:

Bit: $I[\text{byte address}].[\text{bit address}]$ I0.1
 Byte, Word, or Double Word: $I[\text{size}][\text{starting byte address}]$ IB4

Process-Image Output Register: Q

At the end of the scan cycle, the S7-200 copies the values stored in the process-image output register to the physical output points. You can access the process-image output register in bits, bytes, words, or double words:

Bit: $Q[\text{byte address}].[\text{bit address}]$ Q1.1
 Byte, Word, or Double Word: $Q[\text{size}][\text{starting byte address}]$ QB5

Variable Memory Area: V

You can use V memory to store intermediate results of operations being performed by the control logic in your program. You can also use V memory to store other data pertaining to your process or task. You can access the V memory area in bits, bytes, words, or double words:

Bit: $V[\text{byte address}].[\text{bit address}]$ V10.2
 Byte, Word, or Double Word: $V[\text{size}][\text{starting byte address}]$ VW100

Bit Memory Area: M

You can use the bit memory area (M memory) as control relays to store the intermediate status of an operation or other control information. You can access the bit memory area in bits, bytes, words, or double words:

Bit: $M[\text{byte address}].[\text{bit address}]$ M26.7
 Byte, Word, or Double Word: $M[\text{size}][\text{starting byte address}]$ MD20

Timer Memory Area: T

The S7-200 provides timers that count increments of time in resolutions (time-base increments) of 1 ms, 10 ms, or 100 ms. Two variables are associated with a timer:

- Current value: this 16-bit signed integer stores the amount of time counted by the timer.
- Timer bit: this bit is set or cleared as a result of comparing the current and the preset value. The preset value is entered as part of the timer instruction.

You access both of these variables by using the timer address (T + timer number). Access to either the timer bit or the current value is dependent on the instruction used: instructions with bit operands access the timer bit, while instructions with word operands access the current value. As shown in Figure 4-5, the Normally Open Contact instruction accesses the timer bit, while the Move Word instruction accesses the current value of the timer.

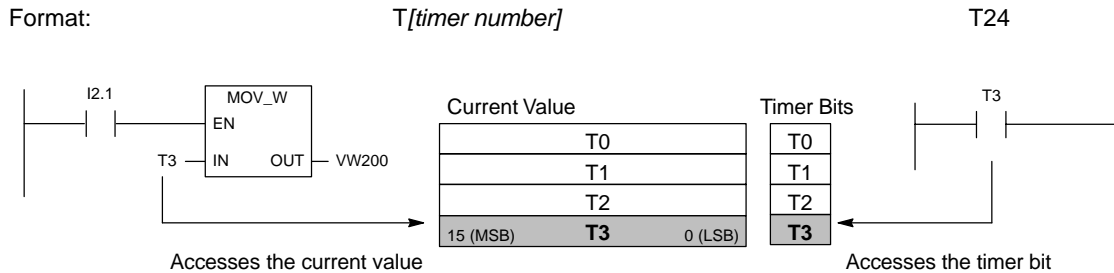

Figure 4-5 Accessing the Timer Bit or the Current Value of a Timer

Counter Memory Area: C

The S7-200 provides three types of counters that count each low-to-high transition event on the counter input(s): one type counts up only, one type counts down only, and one type counts both up and down. Two variables are associated with a counter:

- Current value: this 16-bit signed integer stores the accumulated count.
- Counter bit: this bit is set or cleared as a result of comparing the current and the preset value. The preset value is entered as part of the counter instruction.

You access both of these variables by using the counter address (C + counter number). Access to either the counter bit or the current value is dependent on the instruction used: instructions with bit operands access the counter bit, while instructions with word operands access the current value. As shown in Figure 4-6, the Normally Open Contact instruction accesses the counter bit, while the Move Word instruction accesses the current value of the counter.

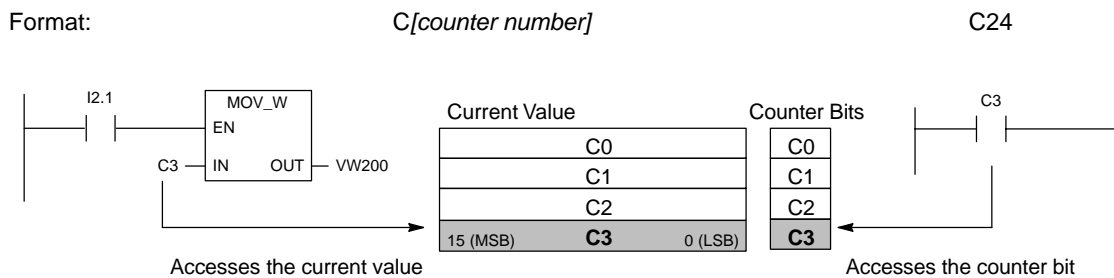

Figure 4-6 Accessing the Counter Bit or the Current Value of a Counter

High-Speed Counters: HC

The high-speed counters count high-speed events independent of the CPU scan. High-speed counters have a signed, 32-bit integer counting value (or current value). To access the count value for the high-speed counter, you specify the address of the high-speed counter, using the memory type (HC) and the counter number (such as HC0). The current value of the high-speed counter is a read-only value and can be addressed only as a double word (32 bits).

Format: $HC[high-speed\ counter\ number]$ HC1

Accumulators: AC

The accumulators are read/write devices that can be used like memory. For example, you can use accumulators to pass parameters to and from subroutines and to store intermediate values used in a calculation. The S7-200 provides four 32-bit accumulators (AC0, AC1, AC2, and AC3). You can access the data in the accumulators as bytes, words, or double words.

The size of the data being accessed is determined by the instruction that is used to access the accumulator. As shown in Figure 4-7, you use the least significant 8 or 16 bits of the value that is stored in the accumulator to access the accumulator as bytes or words. To access the accumulator as a double word, you use all 32 bits.

For information about how to use the accumulators within interrupt subroutines, refer to the Interrupt Instructions in Chapter 6.

Format: $AC[accumulator\ number]$ AC0

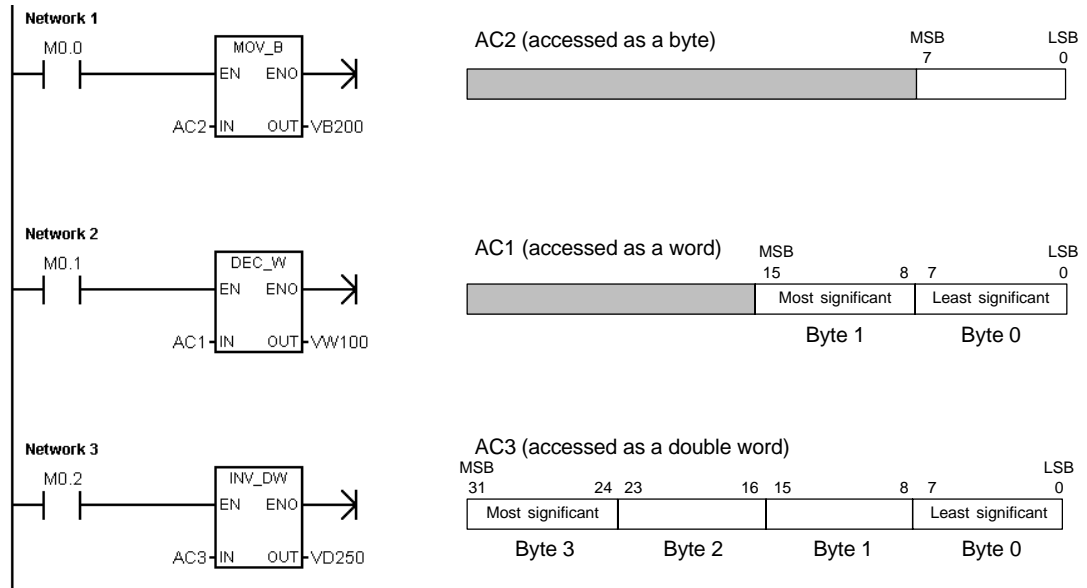

Figure 4-7 Accessing the Accumulators

Special Memory: SM

The SM bits provide a means for communicating information between the CPU and your program. You can use these bits to select and control some of the special functions of the S7-200 CPU, such as: a bit that turns on for the first scan cycle, a bit that toggles at a fixed rate, or a bit that shows the status of math or operational instructions. (For more information about the SM bits, see Appendix D.) You can access the SM bits as bits, bytes, words, or double words:

Bit:	<i>SM[byte address].[bit address]</i>	SM0.1
Byte, Word, or Double Word:	<i>SM[size][starting byte address]</i>	SMB86

Local Memory Area: L

The S7-200 provides 64 bytes of local memory of which 60 can be used as scratchpad memory or for passing formal parameters to subroutines.

**Tip**

If you are programming in either LAD or FBD, STEP 7–Micro/WIN reserves the last four bytes of local memory for its own use. If you program in STL, all 64 bytes of L memory are accessible, but it is recommended that you do not use the last four bytes of L memory.

Local memory is similar to V memory with one major exception. V memory has a global scope while L memory has a local scope. The term global scope means that the same memory location can be accessed from any program entity (main program, subroutines, or interrupt routines). The term local scope means that the memory allocation is associated with a particular program entity. The S7-200 allocates 64 bytes of L memory for the main program, 64 bytes for each subroutine nesting level, and 64 bytes for interrupt routines.

The allocation of L memory for the main program cannot be accessed from subroutines or from interrupt routines. A subroutine cannot access the L memory allocation of the main program, an interrupt routine, or another subroutine. Likewise, an interrupt routine cannot access the L memory allocation of the main program or of a subroutine.

The allocation of L memory is made by the S7-200 on an as-needed basis. This means that while the main portion of the program is being executed, the L memory allocations for subroutines and interrupt routines do not exist. At the time that an interrupt occurs or a subroutine is called, local memory is allocated as required. The new allocation of L memory might reuse the same L memory locations of a different subroutine or interrupt routine.

The L memory is not initialized by the S7-200 at the time of allocation and might contain any value. When you pass formal parameters in a subroutine call, the values of the parameters being passed are placed by the S7-200 in the appropriate L memory locations of the called subroutine. L memory locations, which do not receive a value as a result of the formal parameter passing step, will not be initialized and might contain any value at the time of allocation.

Bit:	<i>L[byte address].[bit address]</i>	L0.0
Byte, Word, or Double Word:	<i>L[size] [starting byte address]</i>	LB33

Format for Strings

A string is a sequence of characters, with each character being stored as a byte. The first byte of the string defines the length of the string, which is the number of characters. Figure 4-9 shows the format for a string. A string can have a length of 0 to 254 characters, plus the length byte, so the maximum length for a string is 255 bytes.

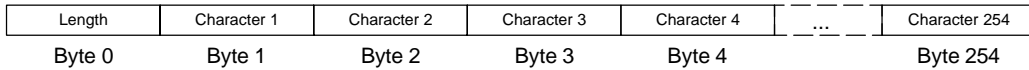

Figure 4-9 Format for Strings

4

Specifying a Constant Value for S7-200 Instructions

You can use a constant value in many of the S7-200 instructions. Constants can be bytes, words, or double words. The S7-200 stores all constants as binary numbers, which can then be represented in decimal, hexadecimal, ASCII, or real number (floating point) formats. See Table 4-2.

Table 4-2 Representation of Constant Values

Representation	Format	Sample
Decimal	[decimal value]	20047
Hexadecimal	16#[hexadecimal value]	16#4E4F
Binary	2#[binary number]	2#1010_0101_1010_0101
ASCII	'[ASCII text]'	'Text goes between single quotes.'
Real	ANSI/IEEE 754–1985	+1.175495E–38 (positive) –1.175495E–38 (negative)



Tip

The S7-200 CPU does not support “data typing” or data checking (such as specifying that the constant is stored as an integer, a signed integer, or a double integer). For example, an Add instruction can use the value in VW100 as a signed integer value, while an Exclusive Or instruction can use the same value in VW100 as an unsigned binary value.

Addressing the Local and Expansion I/O

The local I/O provided by the CPU provides a fixed set of I/O addresses. You can add I/O points to the S7-200 CPU by connecting expansion I/O modules to the right side of the CPU, forming an I/O chain. The addresses of the points of the module are determined by the type of I/O and the position of the module in the chain, with respect to the preceding input or output module of the same type. For example, an output module does not affect the addresses of the points on an input module, and vice versa. Likewise, analog modules do not affect the addressing of digital modules, and vice versa.



Tip

Digital expansion modules always reserve process-image register space in increments of eight bits (one byte). If a module does not provide a physical point for each bit of each reserved byte, these unused bits cannot be assigned to subsequent modules in the I/O chain. For input modules, the unused bits in reserved bytes are set to zero with each input update cycle.

Analog expansion modules are always allocated in increments of two points. If a module does not provide physical I/O for each of these points, these I/O points are lost and are not available for assignment to subsequent modules in the I/O chain.

4

Figure 4-10 provides an example of the I/O numbering for a particular hardware configuration. The gaps in the addressing (shown as gray italic text) cannot be used by your program.

CPU 224	4 In / 4 Out	8 In	4 Analog In 1 Analog Out	8 Out	4 Analog In 1 Analog Out																																																																																																										
<table border="0"> <tr><td>I0.0</td><td>Q0.0</td></tr> <tr><td>I0.1</td><td>Q0.1</td></tr> <tr><td>I0.2</td><td>Q0.2</td></tr> <tr><td>I0.3</td><td>Q0.3</td></tr> <tr><td>I0.4</td><td>Q0.4</td></tr> <tr><td>I0.5</td><td>Q0.5</td></tr> <tr><td>I0.6</td><td>Q0.6</td></tr> <tr><td>I0.7</td><td>Q0.7</td></tr> <tr><td>I1.0</td><td>Q1.0</td></tr> <tr><td>I1.1</td><td>Q1.1</td></tr> <tr><td>I1.2</td><td>Q1.2</td></tr> <tr><td>I1.3</td><td>Q1.3</td></tr> <tr><td>I1.4</td><td>Q1.4</td></tr> <tr><td>I1.5</td><td>Q1.5</td></tr> <tr><td>I1.6</td><td>Q1.6</td></tr> <tr><td>I1.7</td><td>Q1.7</td></tr> </table> <p>Local I/O</p>	I0.0	Q0.0	I0.1	Q0.1	I0.2	Q0.2	I0.3	Q0.3	I0.4	Q0.4	I0.5	Q0.5	I0.6	Q0.6	I0.7	Q0.7	I1.0	Q1.0	I1.1	Q1.1	I1.2	Q1.2	I1.3	Q1.3	I1.4	Q1.4	I1.5	Q1.5	I1.6	Q1.6	I1.7	Q1.7	<table border="0"> <tr><td colspan="2">Module 0</td></tr> <tr><td>I2.0</td><td>Q2.0</td></tr> <tr><td>I2.1</td><td>Q2.1</td></tr> <tr><td>I2.2</td><td>Q2.2</td></tr> <tr><td>I2.3</td><td>Q2.3</td></tr> <tr><td><i>I2.4</i></td><td><i>Q2.4</i></td></tr> <tr><td><i>I2.5</i></td><td><i>Q2.5</i></td></tr> <tr><td><i>I2.6</i></td><td><i>Q2.6</i></td></tr> <tr><td><i>I2.7</i></td><td><i>Q2.7</i></td></tr> </table>	Module 0		I2.0	Q2.0	I2.1	Q2.1	I2.2	Q2.2	I2.3	Q2.3	<i>I2.4</i>	<i>Q2.4</i>	<i>I2.5</i>	<i>Q2.5</i>	<i>I2.6</i>	<i>Q2.6</i>	<i>I2.7</i>	<i>Q2.7</i>	<table border="0"> <tr><td colspan="2">Module 1</td></tr> <tr><td>I3.0</td><td></td></tr> <tr><td>I3.1</td><td></td></tr> <tr><td>I3.2</td><td></td></tr> <tr><td>I3.3</td><td></td></tr> <tr><td>I3.4</td><td></td></tr> <tr><td>I3.5</td><td></td></tr> <tr><td>I3.6</td><td></td></tr> <tr><td>I3.7</td><td></td></tr> </table>	Module 1		I3.0		I3.1		I3.2		I3.3		I3.4		I3.5		I3.6		I3.7		<table border="0"> <tr><td colspan="2">Module 2</td></tr> <tr><td>AIW0</td><td>AQW0</td></tr> <tr><td>AIW2</td><td><i>AQW2</i></td></tr> <tr><td>AIW4</td><td></td></tr> <tr><td>AIW6</td><td></td></tr> </table>	Module 2		AIW0	AQW0	AIW2	<i>AQW2</i>	AIW4		AIW6		<table border="0"> <tr><td colspan="2">Module 3</td></tr> <tr><td>Q3.0</td><td></td></tr> <tr><td>Q3.1</td><td></td></tr> <tr><td>Q3.2</td><td></td></tr> <tr><td>Q3.3</td><td></td></tr> <tr><td>Q3.4</td><td></td></tr> <tr><td>Q3.5</td><td></td></tr> <tr><td>Q3.6</td><td></td></tr> <tr><td>Q3.7</td><td></td></tr> </table>	Module 3		Q3.0		Q3.1		Q3.2		Q3.3		Q3.4		Q3.5		Q3.6		Q3.7		<table border="0"> <tr><td colspan="2">Module 4</td></tr> <tr><td>AIW8</td><td>AQW4</td></tr> <tr><td>AIW10</td><td><i>AQW6</i></td></tr> <tr><td>AIW12</td><td></td></tr> <tr><td>AIW14</td><td></td></tr> </table>	Module 4		AIW8	AQW4	AIW10	<i>AQW6</i>	AIW12		AIW14	
I0.0	Q0.0																																																																																																														
I0.1	Q0.1																																																																																																														
I0.2	Q0.2																																																																																																														
I0.3	Q0.3																																																																																																														
I0.4	Q0.4																																																																																																														
I0.5	Q0.5																																																																																																														
I0.6	Q0.6																																																																																																														
I0.7	Q0.7																																																																																																														
I1.0	Q1.0																																																																																																														
I1.1	Q1.1																																																																																																														
I1.2	Q1.2																																																																																																														
I1.3	Q1.3																																																																																																														
I1.4	Q1.4																																																																																																														
I1.5	Q1.5																																																																																																														
I1.6	Q1.6																																																																																																														
I1.7	Q1.7																																																																																																														
Module 0																																																																																																															
I2.0	Q2.0																																																																																																														
I2.1	Q2.1																																																																																																														
I2.2	Q2.2																																																																																																														
I2.3	Q2.3																																																																																																														
<i>I2.4</i>	<i>Q2.4</i>																																																																																																														
<i>I2.5</i>	<i>Q2.5</i>																																																																																																														
<i>I2.6</i>	<i>Q2.6</i>																																																																																																														
<i>I2.7</i>	<i>Q2.7</i>																																																																																																														
Module 1																																																																																																															
I3.0																																																																																																															
I3.1																																																																																																															
I3.2																																																																																																															
I3.3																																																																																																															
I3.4																																																																																																															
I3.5																																																																																																															
I3.6																																																																																																															
I3.7																																																																																																															
Module 2																																																																																																															
AIW0	AQW0																																																																																																														
AIW2	<i>AQW2</i>																																																																																																														
AIW4																																																																																																															
AIW6																																																																																																															
Module 3																																																																																																															
Q3.0																																																																																																															
Q3.1																																																																																																															
Q3.2																																																																																																															
Q3.3																																																																																																															
Q3.4																																																																																																															
Q3.5																																																																																																															
Q3.6																																																																																																															
Q3.7																																																																																																															
Module 4																																																																																																															
AIW8	AQW4																																																																																																														
AIW10	<i>AQW6</i>																																																																																																														
AIW12																																																																																																															
AIW14																																																																																																															
Expansion I/O																																																																																																															

Figure 4-10 Sample I/O Addresses for Local and Expansion I/O (CPU 224)

Using Pointers for Indirect Addressing of the S7-200 Memory Areas

Indirect addressing uses a pointer to access the data in memory. Pointers are double word memory locations that contain the address of another memory location. You can only use V memory locations, L memory locations, or accumulator registers (AC1, AC2, AC3) as pointers. To create a pointer, you must use the Move Double Word instruction to move the address of the indirectly addressed memory location to the pointer location. Pointers can also be passed to a subroutine as a parameter.

The S7-200 allows pointers to access the following memory areas: I, Q, V, M, S, T (current value only), and C (current value only). You cannot use indirect addressing to access an individual bit or to access AI, AQ, HC, SM, or L memory areas.

To indirectly access the data in a memory address, you create a pointer to that location by entering an ampersand (&) and the memory location to be addressed. The input operand of the instruction must be preceded with an ampersand (&) to signify that the address of a memory location, instead of its contents, is to be moved into the location identified in the output operand of the instruction (the pointer).

Entering an asterisk (*) in front of an operand for an instruction specifies that the operand is a pointer. As shown in Figure 4-11, entering *AC1 specifies that AC1 is a pointer to the word-length value being referenced by the Move Word (MOVW) instruction. In this example, the values stored in both VB200 and VB201 are moved to accumulator AC0.

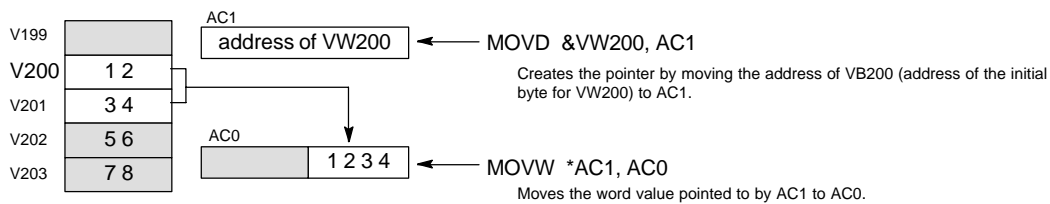

Figure 4-11 Creating and Using a Pointer

As shown in Figure 4-12, you can change the value of a pointer. Since pointers are 32-bit values, use double-word instructions to modify pointer values. Simple mathematical operations, such as adding or incrementing, can be used to modify pointer values.

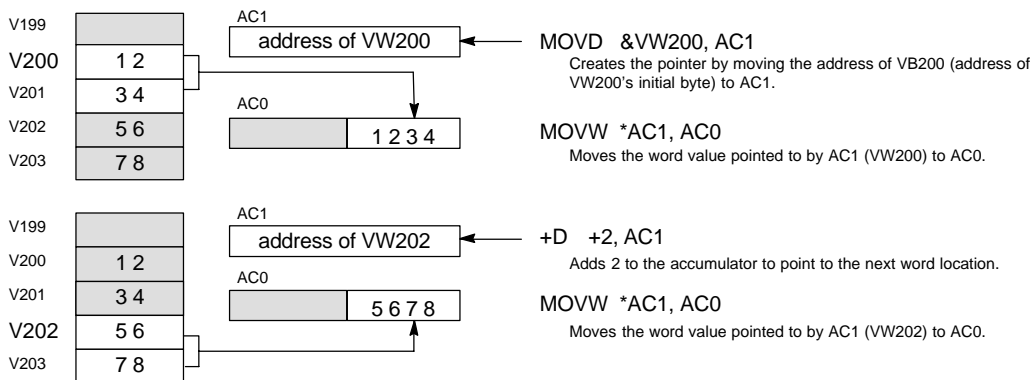

Figure 4-12 Modifying a Pointer



Tip

Remember to adjust for the size of the data that you are accessing: to access a byte, increment the pointer value by 1; to access a word or a current value for a timer or counter, add or increment the pointer value by 2; and to access a double word, add or increment the pointer value by 4.

Sample Program for Using an Offset to Access Data in V Memory

This example uses LD10 as a pointer to the address VB0. You then increment the pointer by an offset stored in VD1004. LD10 then points to another address in V memory (VB0 + offset). The value stored in the V memory address pointed to by LD10 is then copied to VB1900. By changing the value in VD1004, you can access any V memory location.

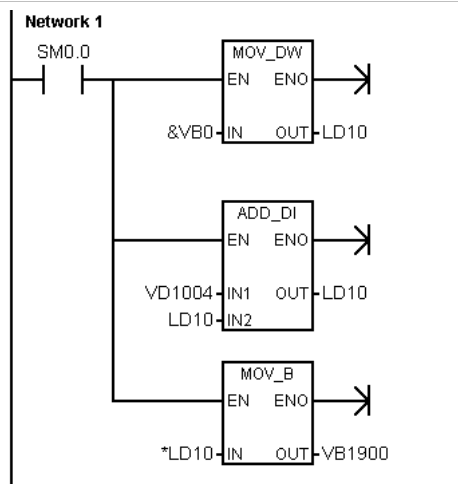

Network 1 //How to use an offset to read the value of any VB location:
 //
 //1. Load the starting address of the V memory to a pointer.
 //2. Add the offset value to the pointer.
 //3. Copy the value from the V memory location (offset) to VB1900.

```
LD SM0.0
MOVD &VB0, LD10
+D VD1004, LD10
MOVB *LD10, VB1900
```

4

Sample Program for Using a Pointer to Access Data in a Table

This example uses LD14 as a pointer to a recipe stored in a table of recipes that begins at VB100. In this example, VW1008 stores the index to a specific recipe in the table. If each recipe in the table is 50 bytes long, you multiply the index by 50 to obtain the offset for the starting address of a specific recipe. By adding the offset to the pointer, you can access the individual recipe from the table. In this example, the recipe is copied to the 50 bytes that start at VB1500.

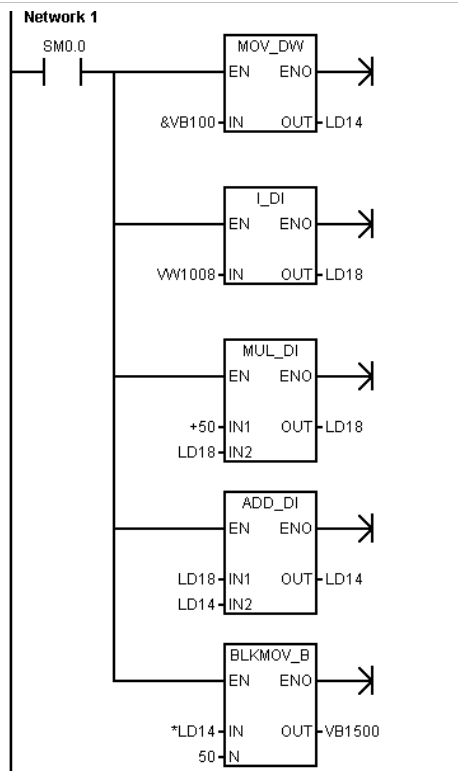

Network 1 //How to transfer a recipe from a table of recipes:
 // – Each recipe is 50 bytes long.
 // – The index parameter (VW1008) identifies the recipe
 // to be loaded.
 //
 //1. Create a pointer to the starting address of the recipe table.
 //2. Convert the index of the recipe to a double-word value.
 //3. Multiply the offset to accommodate the size of each recipe.
 //4. Add the adjusted offset to the pointer.
 //5. Transfer the selected recipe to VB1500 through VB1549.

```
LD SM0.0
MOVD &VB100, LD14
ITD VW1008, LD18
*D +50, LD18
+D LD18, LD14
BMB *LD14, VB1500, 50
```

Understanding How the S7-200 Saves and Restores Data

The S7-200 provides a variety of safeguards to ensure that your program, the program data, and the configuration data for your S7-200 are properly retained.

The S7-200 provides a super capacitor that maintains the integrity of the RAM after power has been removed. Depending on the model of the S7-200, the super capacitor can maintain the RAM for several days.

The S7-200 provides an EEPROM to store permanently all of your program, user-selected data areas, and the configuration data.

The S7-200 also supports an optional battery cartridge that extends the amount of time that the RAM can be maintained after power has been removed from the S7-200. The battery cartridge provides power only after the super capacitor has been drained.

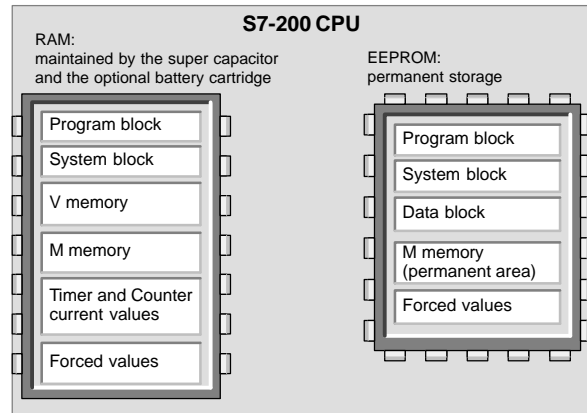

Figure 4-13 Storage Areas of the S7-200 CPU

Downloading and Uploading the Elements of Your Project

Your project consists of three elements: the program block, the data block (optional), and the system block (optional).

Figure 4-14 shows how a project is downloaded to the S7-200.

When you download a project, the elements of a downloaded project are stored in the the RAM area. The S7-200 also automatically copies the user program, data block, and the system block to the EEPROM for permanent storage.

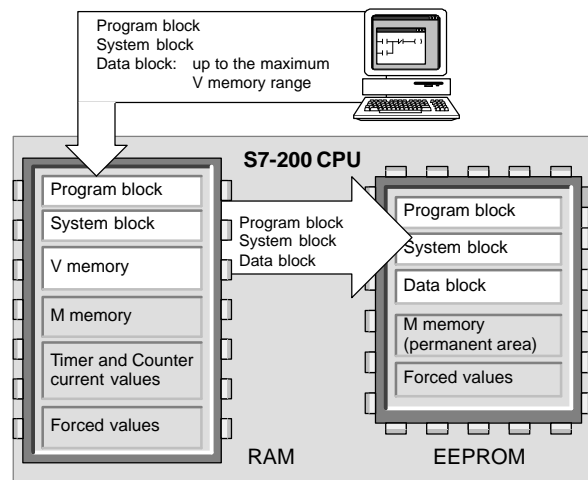

Figure 4-14 Downloading a Project to the S7-200

Figure 4-15 shows how a project is uploaded from the S7-200.

When you upload a project to your computer, the S7-200 uploads the system block from the RAM and uploads the program block and the data block from the EEPROM.

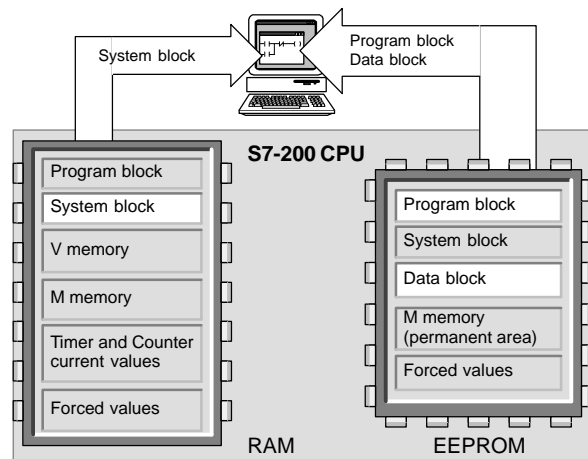

Figure 4-15 Uploading a Project from the S7-200

Saving the Retentive M Memory Area on Power Loss

If you configured the first 14 bytes of bit memory (MB0 to MB13) to be retentive, these bytes are permanently saved to the EEPROM in the event that the S7-200 loses power.

As shown in Figure 4-16, the S7-200 moves these retentive areas of M memory to the EEPROM.

The default setting for the first 14 bytes of M memory is to be non-retentive. The default disables the save that normally occurs when you power off the S7-200.

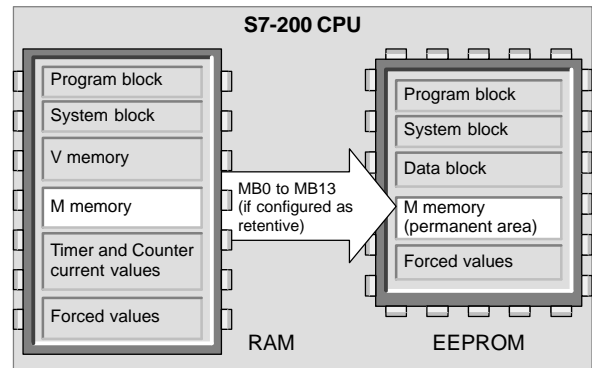

Figure 4-16 Saving the M Memory on Power Loss

4

Restoring Data After Power On

At power on, the S7-200 restores the program block and the system block from the EEPROM memory, as shown in Figure 4-17. Also at power on, the S7-200 checks the RAM to verify that the super capacitor successfully maintained the data stored in RAM memory. If the RAM was successfully maintained, the retentive areas of RAM are left unchanged.

The retentive and non-retentive areas of V memory are restored from the corresponding data block in the EEPROM. If the contents of the RAM were not maintained (such as after an extended power failure), the S7-200 clears the RAM (including both the retentive and non-retentive ranges) and sets the Retentive Data Lost memory bit (SM0.2) for the first scan cycle following power on, and then copies the data stored in the EEPROM to the RAM.

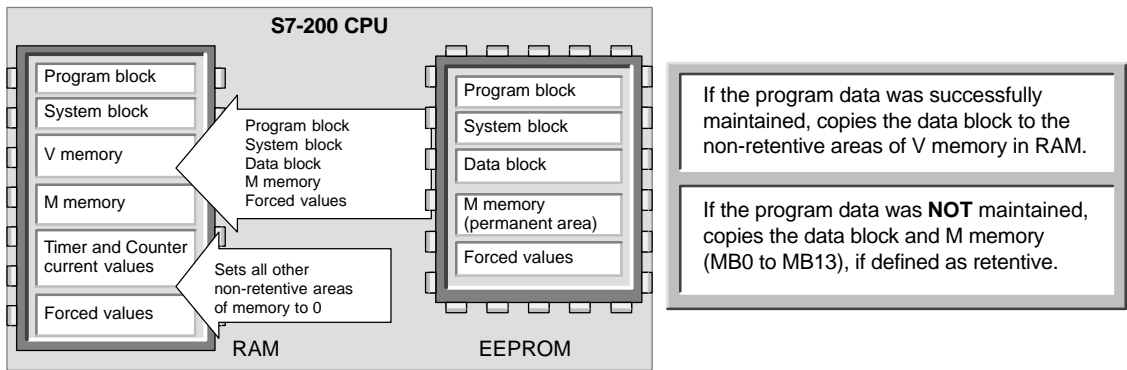

Figure 4-17 Restoring Data after Power On

Storing Your Program on a Memory Cartridge

The S7-200 supports an optional memory cartridge that provides a portable EEPROM storage for your program. The S7-200 stores the following elements on the memory cartridge: the program block, the data block, the system block, and the forced values.

You can copy your program to the memory cartridge from the RAM only when the S7-200 is powered on and in STOP mode and the memory cartridge is installed. You can install or remove the memory cartridge while the S7-200 is powered on.

Caution

Electrostatic discharge can damage the memory cartridge or the receptacle on the S7-200 CPU.

Make contact with a grounded conductive pad and/or wear a grounded wrist strap when you handle the cartridge. Store the cartridge in a conductive container.

To install the memory cartridge, remove the plastic slot cover from the S7-200 CPU and insert the memory cartridge in the slot. The memory cartridge is keyed for proper installation.

Copying Your Program to the Memory Cartridge

After installing the memory cartridge, use the following procedure to copy the program:

1. Put the S7-200 CPU in STOP mode.
2. If the program has not already been downloaded to the S7-200, download the program.
3. Select the **PLC > Program Memory Cartridge** menu command to copy the program to the memory cartridge. Figure 4-18 shows the elements of the CPU memory that are stored on the memory cartridge.
4. Optional: Remove the memory cartridge and replace the cover on the S7-200.

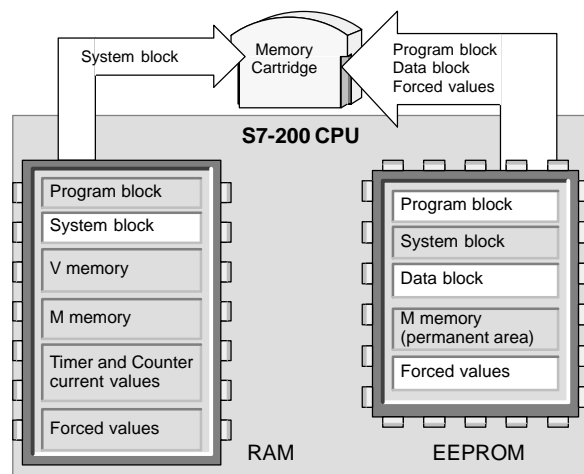

Figure 4-18 Copying to a Memory Cartridge

Restoring the Program from a Memory Cartridge

To transfer the program from a memory cartridge to the S7-200, you must cycle the power to the S7-200 with the memory cartridge installed.

Notice

Powering on an S7-200 CPU with a blank memory cartridge or a memory cartridge that was programmed by a different model of S7-200 CPU could cause an error. Memory cartridges that were programmed by a lower model number CPU can be read by a higher model number CPU. However, the opposite is not true. For example, memory cartridges that were programmed by a CPU 221 or CPU 222 can be read by a CPU 224, but memory cartridges that were programmed by a CPU 224 are rejected by a CPU 221 or CPU 222.

Remove the memory cartridge and turn the power on for the S7-200. After power on, the memory cartridge can then be inserted and reprogrammed, if required.

As shown in Figure 4-19, the S7-200 performs the following tasks after you cycle power with the memory cartridge installed:

1. If the contents of the memory cartridge differ from the contents of the EEPROM, the S7-200 clears the RAM.
2. The S7-200 copies the contents of the memory cartridge to the RAM.
3. The S7-200 copies the program block, the system block, and the data block to the EEPROM.

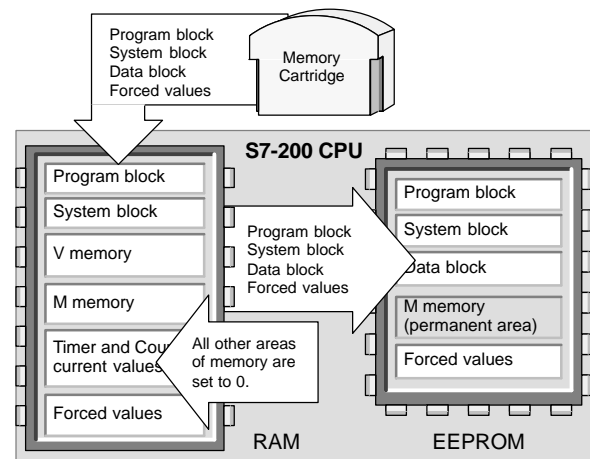

Figure 4-19 Restoring from a Memory Cartridge

Selecting the Operating Mode for the S7-200 CPU

The S7-200 has two modes of operation: STOP mode and RUN mode. The status LED on the front of the CPU indicates the current mode of operation. In STOP mode, the S7-200 is not executing the program, and you can download a program or the CPU configuration. In RUN mode, the S7-200 is running the program.

- ❑ The S7-200 provides a mode switch for changing the mode of operation. You can use the mode switch (located under the front access door of the S7-200) to manually select the operating mode: setting the mode switch to STOP mode stops the execution of the program; setting the mode switch to RUN mode starts the execution of the program; and setting the mode switch to TERM (terminal) mode does not change the operating mode.

If a power cycle occurs when the mode switch is set to either STOP or TERM, the S7-200 goes automatically to STOP mode when power is restored. If a power cycle occurs when the mode switch is set to RUN, the S7-200 goes to RUN mode when power is restored.

- ❑ STEP 7–Micro/WIN allows you to change the operating mode of the online S7-200. To enable the software to change the operating mode, you must manually set the mode switch on the S7-200 to either TERM or RUN. You can use the **PLC > STOP** or **PLC > RUN** menu commands or the associated buttons on the toolbar to change the operating mode.
- ❑ You can insert the STOP instruction in your program to change the S7-200 to STOP mode. This allows you to halt the execution of your program based on the program logic. For more information about the STOP instruction, see Chapter 6.

Using Your Program to Save V Memory to the EEPROM

You can save a value (byte, word, or double word) stored in any location of the V memory area to the EEPROM. A Save-to-EEPROM operation typically increases the scan time by a maximum of 5 ms. The value written by the Save operation overwrites any previous value stored in the V memory area of the EEPROM.

The Save-to-EEPROM operation does not update the data in the memory cartridge.



Tip

Since the number of Save operations to the EEPROM is limited (100,000 minimum, and 1,000,000 typical), you should ensure that only necessary values are saved. Otherwise, the EEPROM can wear out and the CPU can fail. Typically, you should perform Save operations at the occurrence of specific events that occur rather infrequently.

For example, if the scan time of the S7-200 is 50 ms and a value was saved once per scan, the EEPROM would last a minimum of 5,000 seconds, which is less than an hour and a half. On the other hand, if a value were saved once an hour, the EEPROM would last a minimum of 11 years.

4

Copying V Memory to the EEPROM

Special Memory Byte 31 (SMB31) commands the S7-200 to copy a value in V memory to the V memory area of the EEPROM. Special Memory Word 32 (SMW32) stores the address location of the value that is to be copied. Figure 4-20 shows the format of SMB31 and SMW32.

Use the following steps to program the S7-200 to save or write a specific value in V memory:

1. Load the V memory address of the value to be saved in SMW32.
2. Load the size of the data in SM31.0 and SM31.1, as shown in Figure 4-20.
3. Set SM31.7 to 1.

At the end of every scan cycle, the S7-200 checks SM31.7; if SM31.7 equals 1, the specified value is saved to the EEPROM. The operation is complete when the S7-200 resets SM31.7 to 0.

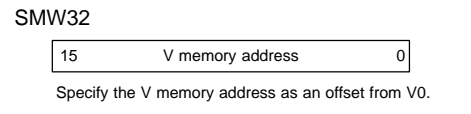
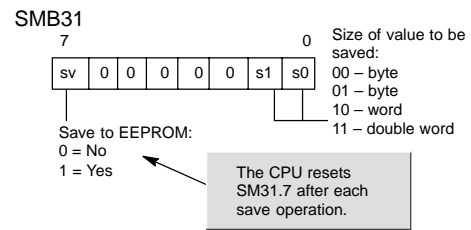

Figure 4-20 SMB31 and SMW32

Do not change the value in V memory until the save operation is complete.

Sample Program: Copying V Memory to the EEPROM

This example transfers VB100 to the EEPROM. On a rising edge of I0.0, if another transfer is not in progress, it loads the address of the V memory location to be transferred to SMW32. It selects the amount of V memory to transfer (1=Byte; 2=Word; 3=Double Word or Real). It then sets SM31.7 to have the S7-200 transfer the data at the end of the scan.

The S7-200 automatically resets SM31.7 when the transfer is complete.

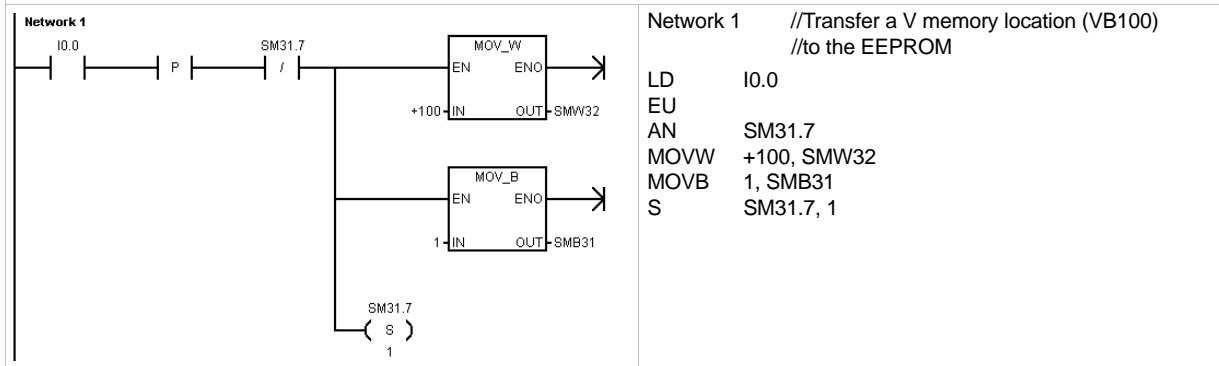

Features of the S7-200

The S7-200 provides several special features that allow you to customize how the S7-200 functions to better fit your application.

The S7-200 Allows Your Program to Immediately Read or Write the I/O

The S7-200 instruction set provides instructions that immediately read from or write to the physical I/O. These immediate I/O instructions allow direct access to the actual input or output point, even though the image registers are normally used as either the source or the destination for I/O accesses.

The corresponding process-image input register location is not modified when you use an immediate instruction to access an input point. The corresponding process-image output register location is updated simultaneously when you use an immediate instruction to access an output point.



Tip

The S7-200 handles reads of analog inputs as immediate data, unless you enable analog input filtering. When you write a value to an analog output, the output is updated immediately.

It is usually advantageous to use the process-image register rather than to directly access inputs or outputs during the execution of your program. There are three reasons for using the image registers:

- The sampling of all inputs at the start of the scan synchronizes and freezes the values of the inputs for the program execution phase of the scan cycle. The outputs are updated from the image register after the execution of the program is complete. This provides a stabilizing effect on the system.
- Your program can access the image register much more quickly than it can access I/O points, allowing faster execution of the program.
- I/O points are bit entities and must be accessed as bits or bytes, but you can access the image register as bits, bytes, words, or double words. Thus, the image registers provide additional flexibility.

The S7-200 Allows Your Program to Interrupt the Scan Cycle

If you use interrupts, the routines associated with each interrupt event are stored as part of the program. The interrupt routines are not executed as part of the normal scan cycle, but are executed when the interrupt event occurs (which could be at any point in the scan cycle).

Interrupts are serviced by the S7-200 on a first-come-first-served basis within their respective priority assignments. See the Interrupt instructions in Chapter 6 for more information.

The S7-200 Allows You to Allocate Processing Time for Communications Tasks

You can configure a percentage of the scan cycle to be dedicated for processing the communications requests that are associated with a RUN mode edit compilation or execution status. (Run mode edit and execution status are options provided by STEP 7–Micro/WIN to make debugging your program easier.) As you increase the percentage of time that is dedicated to processing communications requests, you increase the scan time, which makes your control process run more slowly.

The default percentage of the scan dedicated to processing communications requests is set to 10%. This setting was chosen to provide a reasonable compromise for processing the compilation and status operations while minimizing the impact to your control process. You can adjust this value by 5% increments up to a maximum of 50%. To set the scan cycle time-slice for background communications:

1. Select the **View > Component > System Block** menu command and click on the Background Time tab.
2. Edit the properties for the communications background time and click OK.
3. Download the modified system block to the S7-200.

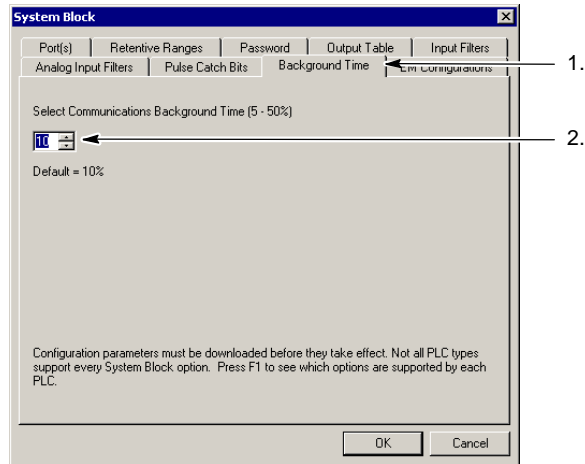

Figure 4-21 Communications Background Time

The S7-200 Allows You to Set the States of Digital Outputs for Stop Mode

The output table of the S7-200 allows you to determine whether to set the state of the digital output points to known values upon a transition to the STOP mode, or to leave the outputs in the state they were in before the transition to the STOP mode. The output table is part of the system block that is downloaded and stored in the S7-200 and applies only to the digital outputs.

1. Select the **View > Component > System Block** menu command and click on the Output Table tab.
2. To freeze the outputs in their last state, select the Freeze Outputs check box.
3. To copy the table values to the outputs, enter the output table values by clicking the checkbox for each output bit you want to set to On (1) after a run-to-stop transition. (The default values of the table are all zeroes.)
4. Click OK to save your selections.
5. Download the modified system block to the S7-200.

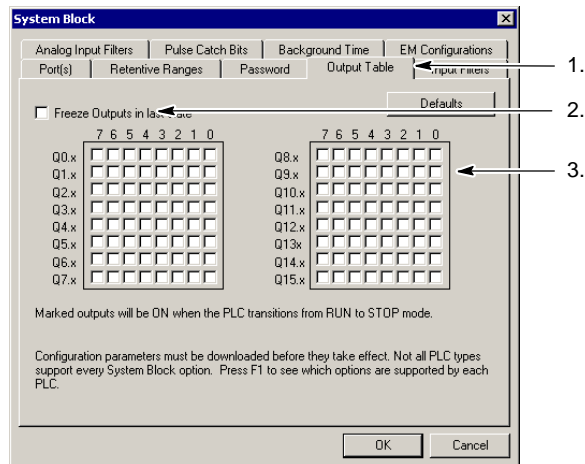

Figure 4-22 Configuring the Output Table

The S7-200 Allows You to Define Memory to Be Retained on Loss of Power

You can define up to six retentive ranges to select the areas of memory you want to retain through power cycles. You can define ranges of addresses in the following memory areas to be retentive: V, M, C, and T. For timers, only the retentive timers (TONR) can be retained. The default setting for the first 14 bytes of M Memory is to be non-retentive.

Only the current values for timers and counters can be retained: the timer and counter bits are not retentive.



Tip

Changing the range MB0 to MB13 to be retentive enables a special feature that automatically saves these locations to the EEPROM on power down.

To define the retentive memory:

1. Select the **View > Component > System Block** menu command and click on the Retentive Ranges tab.
2. Select the ranges of memory to be retained following loss of power and click OK.
3. Download the modified system block to the S7-200.

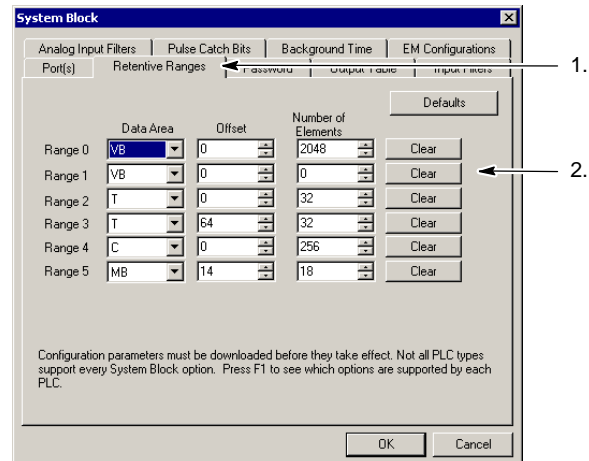

Figure 4-23 Retentive Memory

The S7-200 Allows You to Filter the Digital Inputs

The S7-200 allows you to select an input filter that defines a delay time (selectable from 0.2 ms to 12.8 ms) for some or all of the local digital input points. This delay helps to filter noise on the input wiring that could cause inadvertent changes to the states of the inputs.

The input filter is part of the system block that is downloaded and stored in the S7-200. The default filter time is 6.4 ms. As shown in Figure 4-24, each delay specification applies to groups of input points.

To configure the delay times for the input filter:

1. Select the **View > Component > System Block** menu command and click on the Input Filters tab.
2. Enter the amount of delay for each group of inputs and click OK.
3. Download the modified system block to the S7-200.

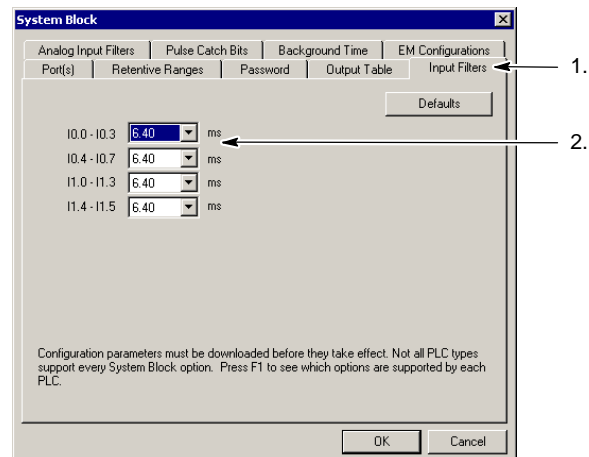

Figure 4-24 Configuring the Input Filters



Tip

The digital input filter affects the input value as seen by instruction reads, input interrupts, and pulse catches. Depending on your filter selection, your program could miss an interrupt event or pulse catch. The high speed counters count the events on the unfiltered inputs.

The S7-200 Allows You to Filter the Analog Inputs

The S7-200 allows you to select software filtering on individual analog inputs. The filtered value is the average value of a preselected number of samples of the analog input. The filter specification (number of samples and deadband) is the same for all analog inputs for which filtering is enabled.

The filter has a fast response feature to allow large changes to be quickly reflected in the filter value. The filter makes a step function change to the latest analog input value when the input exceeds a specified change from the current value. This change, called the deadband, is specified in counts of the digital value of the analog input.

The default configuration is to enable filtering for all analog inputs.

4

1. Select the **View > Component > System Block** menu command and click on the Analog Input Filters tab.
2. Select the analog inputs that you want to filter, the number of samples, and the deadband.
3. Click OK.
4. Download the modified system block to the S7-200.

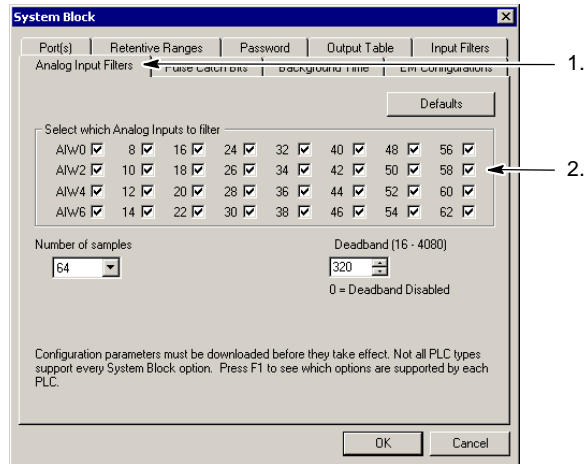

Figure 4-25 Analog Input Filter



Tip

Do not use the analog filter with modules that pass digital information or alarm indications in the analog words. Always disable analog filtering for RTD, Thermocouple, and AS-Interface Master modules.

The S7-200 Allows You to Catch Pulses of Short Duration

The S7-200 provides a pulse catch feature which can be used for some or all of the local digital input points. The pulse catch feature allows you to capture high-going pulses or low-going pulses that are of such a short duration that they would not always be seen when the S7-200 reads the digital inputs at the beginning of the scan cycle. When pulse catch is enabled for an input, a change in state of the input is latched and held until the next input cycle update. This ensures that a pulse which lasts for a short period of time is caught and held until the S7-200 reads the inputs.

You can individually enable the pulse catch operation for each of the local digital inputs.

To access the pulse catch configuration screen:

1. Select the **View > Component > System Block** menu command and click on the Pulse Catch Bits tab.
2. Click the corresponding check box and click OK.
3. Download the modified system block to the S7-200.

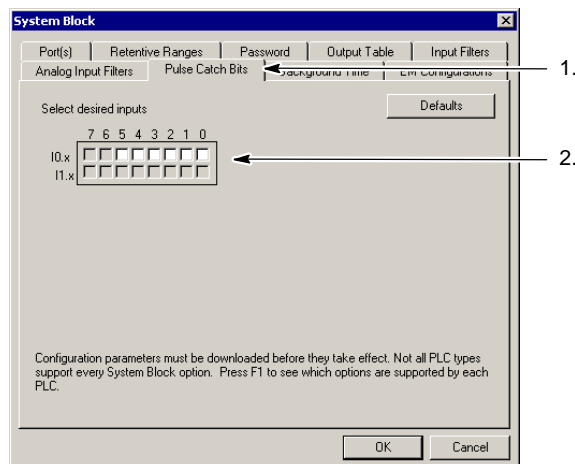

Figure 4-26 Pulse Catch

Figure 4-27 shows the basic operation of the S7-200 with and without pulse catch enabled.

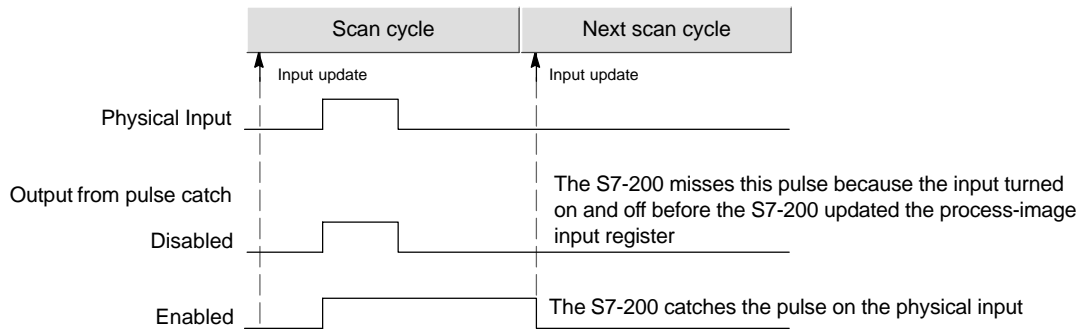

Figure 4-27 Operation of the S7-200 with the Pulse Catch Feature Enabled and Disabled

Because the pulse catch function operates on the input after it passes through the input filter, you must adjust the input filter time so that the pulse is not removed by the filter. Figure 4-28 shows a block diagram of the digital input circuit.

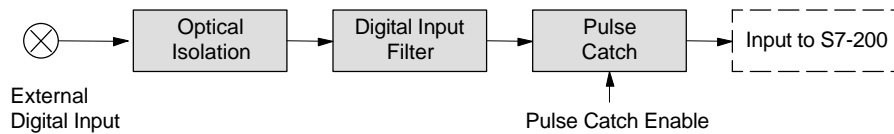

Figure 4-28 Digital Input Circuit

Figure 4-29 shows the response of an enabled pulse catch function to various input conditions. If you have more than one pulse in a given scan, only the first pulse is read. If you have multiple pulses in a given scan, you should use the rising/falling edge interrupt events. (For a listing of interrupt events, see Table 6-44.)

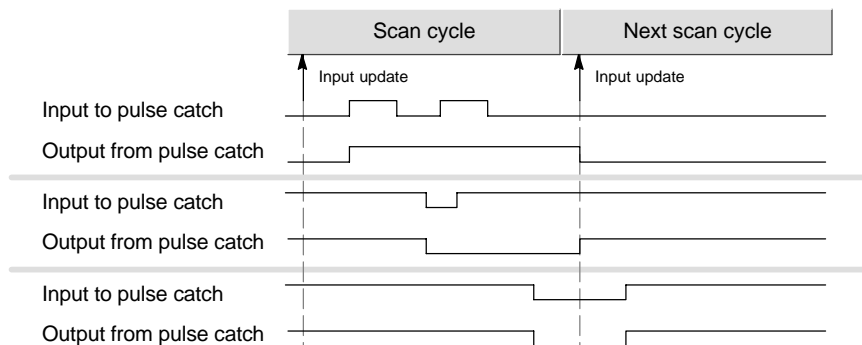

Figure 4-29 Responses of the Pulse Catch Function to Various Input Conditions

The S7-200 Provides Password Protection

All models of the S7-200 provide password protection for restricting access to specific functions.

A password authorizes access to the functions and memory: without a password, the S7-200 provides unrestricted access. When it is password protected, the S7-200 limits all restricted operations according to the configuration provided when the password was installed.

The password is not case sensitive.

As shown in Table 4-3, the S7-200 provides three levels of access restriction. Each level allows certain functions to be accessible without a password. For all three levels of access, entering the correct password provides access to all of the functions. The default condition for the S7-200 is level 1 (no restriction).

Entering the password over a network does not compromise the password protection for the S7-200.

Having one user authorized to access restricted functions does not authorize other users to access those functions. Only one user is allowed unrestricted access to the S7-200 at a time.

Table 4-3 Restricting Access to the S7-200

CPU Function	Level 1	Level 2	Level 3
Read and write user data	Access Allowed	Access Allowed	Access Allowed
Start, stop, and restart the CPU			
Read and write the time-of-day clock			
Upload the user program, data, and the CPU configuration	Access Allowed	Access Allowed	Password required
Download to the CPU	Access Allowed	Password required	
Get the execution status			
Delete the program block, data block, or system block			
Force data or execute the single/multiple scan			
Copy to the memory cartridge			
Write outputs in STOP mode			



Tip

After you enter the password, the authorization level for that password remains effective for up to one minute after the programming device has been disconnected from the S7-200. Always exit STEP 7-Micro/WIN before disconnecting the cable to prevent another user from accessing the privileges of the programming device.

Configuring a Password for the S7-200

The System Block dialog box (Figure 4-30) allows you to configure a password for the S7-200:

1. Select the **View > Component > System Block** menu command to display the System Block dialog box and click on the Password tab.
2. Select the appropriate level of access for the S7-200.
3. Enter and verify the password.
4. Click OK.
5. Download the modified system block to the S7-200.

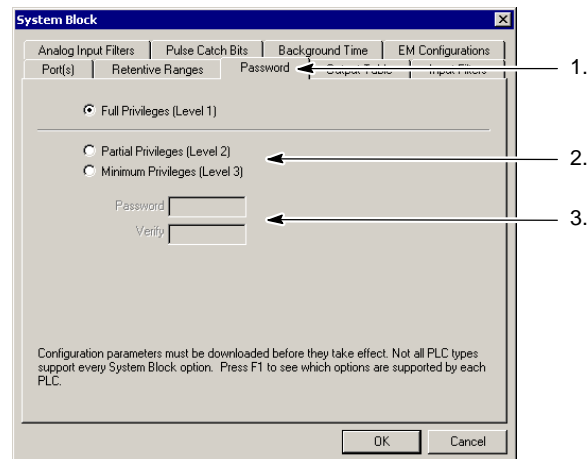

Figure 4-30 Creating a Password

Recovering from a Lost Password

If you forget the password, you must clear the memory of the S7-200 and reload your program. Clearing the memory puts the S7-200 in STOP mode and resets the S7-200 to the factory-set defaults, except for the network address, baud rate, and the time-of-day clock. To clear your program in the S7-200:

1. Select the **PLC > Clear** menu command to display the Clear dialog box.
2. Select all three blocks and confirm your action by clicking OK.
3. If a password had been configured, STEP 7–Micro/WIN displays a password-authorization dialog box. To clear the password, enter CLEARPLC in the password-authorization dialog box to continue the Clear All operation. (The CLEARPLC password is not case sensitive.)

The Clear All operation does not remove the program from a memory cartridge. Since the memory cartridge stores the password along with the program, you must also reprogram the memory cartridge to remove the lost password.



Warning

Clearing the S7-200 memory causes the outputs to turn off (or in the case of an analog output, to be frozen at a specific value).

If the S7-200 is connected to equipment when you clear the memory, changes in the state of the outputs can be transmitted to the equipment. If you had configured the “safe state” for the outputs to be different from the factory settings, changes in the outputs could cause unpredictable operation of your equipment, which in turn could cause death or serious injury to personnel, and/or damage to equipment.

Always follow appropriate safety precautions and ensure that your process is in a safe state before clearing the S7-200 memory.

The S7-200 Provides Analog Adjustment Potentiometers

The analog adjustment potentiometers are located under the front access cover of the module. You can adjust these potentiometers to increase or decrease values that are stored in bytes of Special Memory (SMB). These read-only values can be used by the program for a variety of functions, such as updating the current value for a timer or a counter, entering or changing the preset values, or setting limits. Use a small screwdriver to make the adjustments: turn the potentiometer clockwise (to the right) to increase the value, and counterclockwise (to the left) to decrease the value.

SMB28 holds the digital value that represents the position of analog adjustment 0. SMB29 holds the digital value that represents the position of analog adjustment 1. The analog adjustment has a nominal range of 0 to 255 and a repeatability of ±2 counts.

Sample Program for Referencing the Value Entered with the Analog Adjustment Potentiometers	
	<pre> Network 1 //Read analog adjustment 0 (SMB28). //Save the value as an integer in VW100. LD I0.0 BTI SMB28, VW100 Network 2 //Use the integer value (VW100) as a preset for a timer. LDN Q0.0 TON T33, VW100 Network 3 //Turn on Q0.0 when T33 reaches the preset value. LD T33 = Q0.0 </pre>

The S7-200 Provides High-speed I/O

High-Speed Counters

The S7-200 provides integrated high-speed counter functions that count high speed external events without degrading the performance of the S7-200. See Appendix A for the rates supported by your CPU model. Each counter has dedicated inputs for clocks, direction control, reset, and start, where these functions are supported. You can select different quadrature modes for varying the counting rate. For more information on high-speed counters, see Chapter 6.

High-Speed Pulse Output

The S7-200 supports high-speed pulse outputs, with outputs Q0.0 and Q0.1 generating either a high-speed pulse train output (PTO) or pulse width modulation (PWM).

The PTO function provides a square wave (50% duty cycle) output for a specified number of pulses (from 1 to 4,294,967,295 pulses) and a specified cycle time (in either microsecond or millisecond increments either from 50 μ s to 65,535 μ s or from 2 ms to 65,535 ms). You can program the PTO function to produce either one train of pulses or a pulse profile consisting of multiple trains of pulses. For example, you can use a pulse profile to control a stepper motor through a simple ramp up, run, and ramp down sequence or more complicated sequences. The pulse profile can consist of up to 255 segments with a segment corresponding to the ramp up or run or ramp down operation.

The PWM function provides a fixed cycle time with a variable duty cycle output, with the cycle time and the pulse width specified in either microsecond or millisecond increments. The cycle time has a range either from 50 μ s to 65,535 μ s or from 2 ms to 65,535 ms. The pulse width time has a range either from 0 μ s to 65,535 μ s or from 0 ms to 65,535 ms. When the pulse width is equal to the cycle time, the duty cycle is 100 percent and the output is turned on continuously. When the pulse width is zero, the duty cycle is 0 percent and the output is turned off.

For more information on the high-speed pulse output instruction, see Chapter 6.

Programming Concepts, Conventions, and Features



The S7-200 continuously executes your program to control a task or process. You use STEP 7–Micro/WIN to create this program and download it to the S7-200. STEP 7–Micro/WIN provides a variety of tools and features for designing, implementing, and debugging your program.

In This Chapter

Guidelines for Designing a Micro PLC System	48
Basic Elements of a Program	49
Using STEP 7–Micro/WIN to Create Your Programs	51
Choosing Between the SIMATIC and IEC 1131–3 Instruction Sets	53
Understanding the Conventions Used by the Program Editors	54
Using Wizards To Help You Create Your Control Program	56
Handling Errors in the S7-200	56
Assigning Addresses and Initial Values in the Data Block Editor	58
Using the Symbol Table for Symbolic Addressing of Variables	58
Using Local Variables	59
Using the Status Chart to Monitor Your Program	59
Creating an Instruction Library	60
Features for Debugging Your Program	60

Guidelines for Designing a Micro PLC System

There are many methods for designing a Micro PLC system. The following general guidelines can apply to many design projects. Of course, you must follow the directives of your own company's procedures and the accepted practices of your own training and location.

Partition Your Process or Machine

Divide your process or machine into sections that have a level of independence from each other. These partitions determine the boundaries between controllers and influence the functional description specifications and the assignment of resources.

Create the Functional Specifications

Write the descriptions of operation for each section of the process or machine. Include the following topics: I/O points, functional description of the operation, states that must be achieved before allowing action for each actuator (such as solenoids, motors, and drives), description of the operator interface, and any interfaces with other sections of the process or machine.

Design the Safety Circuits

Identify equipment requiring hard-wired logic for safety. Control devices can fail in an unsafe manner, producing unexpected startup or change in the operation of machinery. Where unexpected or incorrect operation of the machinery could result in physical injury to people or significant property damage, consideration should be given to the use of electro-mechanical overrides which operate independently of the S7-200 to prevent unsafe operations. The following tasks should be included in the design of safety circuits:

- Identify improper or unexpected operation of actuators that could be hazardous.
- Identify the conditions that would assure the operation is not hazardous, and determine how to detect these conditions independently of the S7-200.
- Identify how the S7-200 CPU and I/O affect the process when power is applied and removed, and when errors are detected. This information should only be used for designing for the normal and expected abnormal operation, and should not be relied on for safety purposes.
- Design manual or electro-mechanical safety overrides that block the hazardous operation independent of the S7-200.
- Provide appropriate status information from the independent circuits to the S7-200 so that the program and any operator interfaces have necessary information.
- Identify any other safety-related requirements for safe operation of the process.

Specify the Operator Stations

Based on the requirements of the functional specifications, create drawings of the operator stations. Include the following items:

- Overview showing the location of each operator station in relation to the process or machine
- Mechanical layout of the devices, such as display, switches, and lights, for the operator station
- Electrical drawings with the associated I/O of the S7-200 CPU or expansion module

Create the Configuration Drawings

Based on the requirements of the functional specification, create configuration drawings of the control equipment. Include the following items:

- Overview showing the location of each S7-200 in relation to the process or machine
- Mechanical layout of the S7-200 and expansion I/O modules (including cabinets and other equipment)
- Electrical drawings for each S7-200 and expansion I/O module (including the device model numbers, communications addresses, and I/O addresses)

Create a List of Symbolic Names (optional)

If you choose to use symbolic names for addressing, create a list of symbolic names for the absolute addresses. Include not only the physical I/O signals, but also the other elements to be used in your program.

Basic Elements of a Program

A program block is composed of executable code and comments. The executable code consists of a main program and any subroutines or interrupt routines. The code is compiled and downloaded to the S7-200; the program comments are not. You can use the organizational elements (main program, subroutines, and interrupt routines) to structure your control program.

The following example shows a program that includes a subroutine and an interrupt routine. This sample program uses a timed interrupt for reading the value of an analog input every 100 ms.

Example: Basic Elements of a Program		
M A I N	<p>Network 1</p>	<p>Network 1 //On first scan, call subroutine 0.</p> <pre>LD SM0.1 CALL SBR_0</pre>
S B R O	<p>Network 1</p>	<p>Network 1 //Set the interval to 100 ms //for the timed interrupt. //Enable interrupt 0.</p> <pre>LD SM0.0 MOVB 100, SMB34 ATCH INT_0, 10 ENI</pre>
I N T O	<p>Network 1</p>	<p>Network 1 //Sample the Analog Input 4.</p> <pre>LD SM0.0 MOVW AIW4, VW100</pre>

Main Program

The main body of the program contains the instructions that control your application. The S7-200 executes these instructions sequentially, once per scan cycle. The main program is also referred to as OB1.

Subroutines

These optional elements of your program are executed only when called: by the main program, by an interrupt routine, or by another subroutine. Subroutines are useful in cases where you want to execute a function repeatedly. Rather than rewriting the logic for each place in the main program where you want the function to occur, you can write the logic once in a subroutine and call the subroutine as many times as needed during the main program. Subroutines provide several benefits:

- Using subroutines reduces the overall size of your program.
- Using subroutines decreases your scan time because you have moved the code out of the main program. The S7-200 evaluates the code in the main program every scan cycle, whether the code is executed or not, but the S7-200 evaluates the code in the subroutine only when you call the subroutine, and does not evaluate the code during the scans in which the subroutine is not called.
- Using subroutines creates code that is portable. You can isolate the code for a function in a subroutine, and then copy that subroutine into other programs with little or no rework.



Tip

Using V memory addresses can limit the portability of your subroutine, because it is possible for V memory address assignment from one program to conflict with an assignment in another program. Subroutines that use the local variable table (L memory) for all address assignments, by contrast, are highly portable because there is no concern about address conflicts between the subroutine and another part of the program when using local variables.

Interrupt Routines

These optional elements of your program react to specific interrupt events. You design an interrupt routine to handle a pre-defined interrupt event. Whenever the specified event occurs, the S7-200 executes the interrupt routine.

The interrupt routines are not called by your main program. You associate an interrupt routine with an interrupt event, and the S7-200 executes the instructions in the interrupt routine only on each occurrence of the interrupt event.



Tip

Because it is not possible to predict when the S7-200 might generate an interrupt, it is desirable to limit the number of variables that are used both by the interrupt routine and elsewhere in the program.

Use the local variable table of the interrupt routine to ensure that your interrupt routine uses only the temporary memory and does not overwrite data used somewhere else in your program.

There are a number of programming techniques you can use to ensure that data is correctly shared between your main program and the interrupt routines. These techniques are described in Chapter 6 with the Interrupt instructions.

Other Elements of the Program

Other blocks contain information for the S7-200. You can choose to download these blocks when you download your program.



System Block

System Block

The system block allows you to configure different hardware options for the S7-200.



Data Block

Data Block

The data block stores the values for different variables (V memory) used by your program. You can use the data block to enter initial values for the data.

Using STEP 7–Micro/WIN to Create Your Programs

To open STEP 7–Micro/WIN, double-click on the STEP 7–Micro/WIN icon, or select the **Start > SIMATIC > STEP 7 MicroWIN 3.2** menu command. As shown in Figure 5-1, the STEP 7–Micro/WIN project window provides a convenient working space for creating your control program.

The toolbars provide buttons for shortcuts to frequently used menu commands. You can view or hide any of the toolbars.

The navigation bar presents groups of icons for accessing different programming features of STEP 7–Micro/WIN.

The instruction tree displays all of the project objects and the instructions for creating your control program. You can drag and drop individual instructions from the tree into your program, or you can double-click an instruction to insert it at the current location of the cursor in the program editor.

The program editor contains the program logic and a local variable table where you can assign symbolic names for temporary local variables. Subroutines and interrupt routines appear as tabs at the bottom of the program editor window. Click on the tabs to move between the subroutines, interrupts, and the main program.

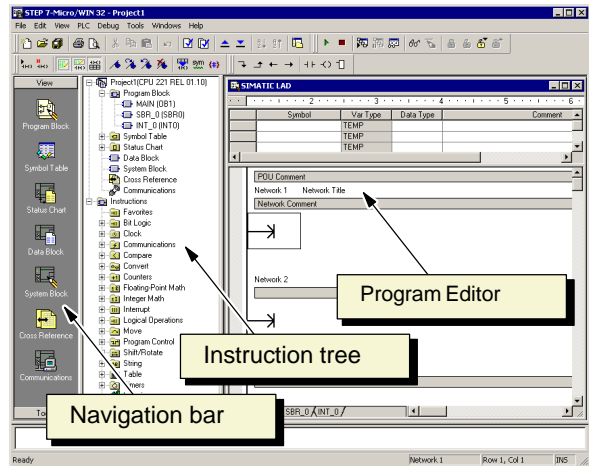

Figure 5-1 STEP 7–Micro/WIN



Program Editor

STEP 7–Micro/WIN provides three editors for creating your program: Ladder Logic (LAD), Statement List (STL), and Function Block Diagram (FBD). With some restrictions, programs written in any of these program editors can be viewed and edited with the other program editors.

Features of the STL Editor

The STL editor displays the program as a text-based language. The STL editor allows you to create control programs by entering the instruction mnemonics. The STL editor also allows you to create programs that you could not otherwise create with the LAD or FBD editors. This is because you are programming in the native language of the S7-200, rather than in a graphical editor where some restrictions must be applied in order to draw the diagrams correctly. As shown in Figure 5-2, this text-based concept is very similar to assembly language programming.

The S7-200 executes each instruction in the order dictated by the program, from top to bottom, and then restarts at the top.

STL uses a logic stack to resolve the control logic. You insert the STL instructions for handling the stack operations.

```
LD  I0.0      //Read one input
A   I0.1      //AND with another input
=   Q1.0      //Write value to output 1
```

Figure 5-2 Sample STL Program

Consider these main points when you select the STL editor:

- STL is most appropriate for experienced programmers.
- STL sometimes allows you to solve problems that you cannot solve very easily with the LAD or FBD editor.
- You can only use the STL editor with the SIMATIC instruction set.
- While you can always use the STL editor to view or edit a program that was created with the LAD or FBD editors, the reverse is not always true. You cannot always use the LAD or FBD editors to display a program that was written with the STL editor.

Features of the LAD Editor

The LAD editor displays the program as a graphical representation similar to electrical wiring diagrams. Ladder programs allow the program to emulate the flow of electric current from a power source through a series of logical input conditions that in turn enable logical output conditions. A LAD program includes a left power rail that is energized. Contacts that are closed allow energy to flow through them to the next element, and contacts that are open block that energy flow.

The logic is separated into networks. The program is executed one network at a time, from left to right and then top to bottom as dictated by the program. Figure 5-3 shows an example of a LAD program. The various instructions are represented by graphic symbols and include three basic forms.

Contacts represent logic input conditions such as switches, buttons, or internal conditions.

Coils usually represent logic output results such as lamps, motor starters, interposing relays, or internal output conditions.

Boxes represent additional instructions, such as timers, counters, or math instructions.

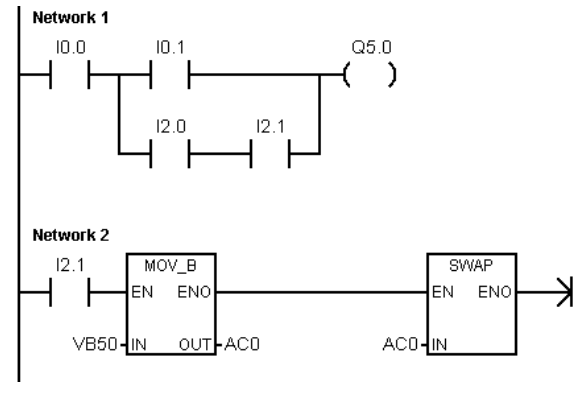

Figure 5-3 Sample LAD Program

Consider these main points when you select the LAD editor:

- Ladder logic is easy for beginning programmers to use.
- Graphical representation is easy to understand and is popular around the world.
- The LAD editor can be used with both the SIMATIC and IEC 1131–3 instruction sets.
- You can always use the STL editor to display a program created with the SIMATIC LAD editor.

Features of the FBD Editor

The FBD editor displays the program as a graphical representation that resembles common logic gate diagrams. There are no contacts and coils as found in the LAD editor, but there are equivalent instructions that appear as box instructions.

Figure 5-4 shows an example of an FBD program.

FBD does not use the concept of left and right power rails; therefore, the term “power flow” is used to express the analogous concept of control flow through the FBD logic blocks.

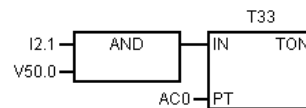

Figure 5-4 Sample FBD Program

The logic “1” path through FBD elements is called power flow. The origin of a power flow input and the destination of a power flow output can be assigned directly to an operand.

The program logic is derived from the connections between these box instructions. That is, the output from one instruction (such as an AND box) can be used to enable another instruction (such as a timer) to create the necessary control logic. This connection concept allows you to solve a wide variety of logic problems.

Consider these main points when you select the FBD editor:

- The graphical logic gate style of representation is good for following program flow.
- The FBD editor can be used with both the SIMATIC and IEC 1131–3 instruction sets.
- You can always use the STL editor to display a program created with the SIMATIC FBD editor.

Choosing Between the SIMATIC and IEC 1131–3 Instruction Sets

Most PLCs offer similar basic instructions, but there are usually small differences from vendor to vendor in appearance, operation, and so forth. Over the last several years, the International Electrotechnical Commission (IEC) has developed an emerging global standard that specifically relates to many aspects of PLC programming. This standard encourages different PLC manufacturers to offer instructions that are the same in both appearance and operation.

Your S7-200 offers two instruction sets that allow you to solve a wide variety of automation tasks. The IEC instruction set complies with the IEC 1131–3 standard for PLC programming, and the SIMATIC instruction set is designed specifically for the S7-200.



Tip

When STEP 7–Micro/WIN is set to the IEC mode, it displays a red diamond (♦) in the Instruction Tree beside the instructions that are not defined by the IEC 1131–3 standard.

There are a few key differences between the SIMATIC instruction set and the IEC instruction set:

- The IEC instruction set is restricted to those instructions that are standard among PLC vendors. Some instructions that are normally included in the SIMATIC set are not standard instructions in the IEC 1131–3 specification. These are still available for use as non-standard instructions, but if you use them, the program is no longer strictly IEC 1131–3 compatible.
- Some IEC box instructions accept multiple data formats. This practice is often referred to as overloading. For example, rather than have separate ADD_I (Add Integer) and ADD_R (Add Real), math boxes, the IEC ADD instruction examines the format of the data being added and automatically chooses the correct instruction in the S7-200. This can save valuable program design time.
- When you use the IEC instructions, the instruction parameters are automatically checked for the proper data format, such as a signed integer versus an unsigned integer. For example, an error results if you try to enter an integer value for an instruction that expected a bit value (on/off). This feature helps to minimize programming syntax errors.

Consider these points when you select either the SIMATIC or the IEC instruction set:

- SIMATIC instructions usually have the shortest execution times. Some IEC instructions might have longer execution times.
- Some IEC instructions, such as timers, counters, multiply, and divide, operate differently than their SIMATIC counterparts.
- You can use all three program editors (LAD, STL, FBD) with the SIMATIC instruction set. You can use only the LAD and FBD program editors for IEC instructions.
- The operation of the IEC instructions is standard for different brands of PLCs, and the knowledge about creating an IEC-compliant program can be leveraged across PLC platforms.
- While the IEC standard defines fewer instructions than are available in the SIMATIC instruction set, you can always include SIMATIC instructions in your IEC program.
- IEC 1131–3 specifies that variables must be declared with a type, and supports system checking of data type.

Understanding the Conventions Used by the Program Editors

STEP 7–Micro/WIN uses the following conventions in all of the program editors:

- A # in front of a symbol name (#var1) indicates that the symbol is of local scope.
- For IEC instructions, the % symbol indicates a direct address.
- The operand symbol “?.?” or “????” indicates that an operand configuration is required.

LAD programs are divided into segments called networks. A network is an ordered arrangement of contacts, coils, and boxes that are all connected to form a complete circuit: no short circuits, no open circuits, and no reverse power flow conditions exist. STEP 7–Micro/WIN allows you to create comments for your LAD program on a network-by-network basis. FBD programming uses the network concept for segmenting and commenting your program.

STL programs do not use networks; however, you can use the NETWORK keyword to segment your program.

5

Conventions Specific to the LAD Editor

In the LAD editor, you can use the F4, F6, and F9 keys on your keyboard to access contact, box, and coil instructions. The LAD editor uses the following conventions:

- The symbol “—>>” is an open circuit or a required power flow connection.
- The symbol “→” indicates that the output is an optional power flow for an instruction that can be cascaded or connected in series.
- The symbol “>>” indicates that you can use power flow.

Conventions Specific to the FBD Editor

In the FBD editor, you can use the F4, F6, and F9 keys on your keyboard to access AND, OR, and box instructions. The FBD editor uses the following conventions:

- The symbol “—>>” on an EN operand is a power flow or operand indicator. It can also depict an open circuit or a required power flow connection.
- The symbol “→” indicates that the output is an optional power flow for an instruction that can be cascaded or connected in series.
- The symbols “<<” and “>>” indicate that you can use either a value or power flow.
- Negation bubbles: The logical NOT condition or inverted condition of the operand or power flow is shown by the small circle on the input. In Figure 5-5, Q0.0 is equal to the NOT of I0.0 AND I0.1. Negation bubbles are only valid for Boolean signals, which can be specified as parameters or power flow.
- Immediate indicators: As shown in Figure 5-5, the FBD editor displays an immediate condition of a Boolean operand with a vertical line on the input to an FBD instruction. The immediate indicator causes an immediate read from the specified physical input. Immediate operators are only valid for physical inputs.
- Box with no input or output: A box with no input indicates an instruction that is independent of power flow.

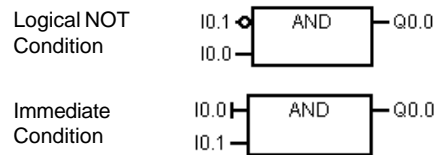

Figure 5-5 FBD Conventions



Tip

The number of operands can be expanded up to 32 inputs for AND and OR instructions. To add or subtract operand tics, use the “+” and “-” keys on your keyboard.

General Conventions of Programming for an S7-200

EN/ENO Definition

EN (Enable IN) is a Boolean input for boxes in LAD and FBD. Power flow must be present at this input for the box instruction to be executed. In STL, the instructions do not have an EN input, but the top of stack value must be a logic “1” for the corresponding STL instruction to be executed.

ENO (Enable Out) is a Boolean output for boxes in LAD and FBD. If the box has power flow at the EN input and the box executes its function without error, then the ENO output passes power flow to the next element. If an error is detected in the execution of the box, then power flow is terminated at the box that generated the error.

In STL, there is no ENO output, but the STL instructions that correspond to the LAD and FBD instructions with ENO outputs do set a special ENO bit. This bit is accessible with the AND ENO (AENO) instruction and can be used to generate the same effect as the ENO bit of a box.



Tip

The EN/ENO operands and data types are not shown in the valid operands table for each instruction because the operands are the same for all LAD and FBD instructions. Table 5-1 lists these operands and data types for LAD and FBD. These operands apply to all LAD and FBD instructions shown in this manual.

Table 5-1 EN/ENO Operands and Data Types for LAD and FBD

Program Editor	Inputs/Outputs	Operands	Data Types
LAD	EN, ENO	Power Flow	BOOL
FBD	EN, ENO	I, Q, V, M, SM, S, T, C, L	BOOL

Conditional/Unconditional Inputs

In LAD and FBD, a box or a coil that is dependent upon power flow is shown with a connection to any element on the left side. A coil or box that is independent of power flow is shown with a connection directly to the left power rail. Table 5-2 shows an example of both a conditional and an unconditional input.

Table 5-2 Representation of Conditional and Unconditional Inputs

Power Flow	LAD	FBD
Instruction that is dependent on power flow (conditional)		
Instruction that is independent of power flow (unconditional)		

Instructions without Outputs

Boxes that cannot cascade are drawn with no Boolean outputs. These include the Subroutine Call, Jump, and Conditional Return instructions. There are also ladder coils that can only be placed on the left power rail. These include the Label, Next, Load SCR, Conditional SCR End, and SCR End instructions. These are shown in FBD as boxes and are distinguished with unlabeled power inputs and no outputs.

Compare Instructions

The compare instruction is executed regardless of the state of power flow. If power flow is false, the output is false. If power flow is true, the output is set depending upon the result of the compare. SIMATIC FBD, IEC Ladder, and IEC FBD compare instructions are shown as boxes, although the operation is performed as a contact.

Using Wizards To Help You Create Your Control Program

STEP 7–Micro/WIN provides wizards to make aspects of your programming easier and more automatic. In Chapter 6, instructions that have an associated wizard are identified by the following Instruction Wizard icon:



Instruction
Wizard

Handling Errors in the S7-200

The S7-200 classifies errors as either fatal errors or non-fatal errors. You can view the error codes that were generated by an error by selecting the **PLC > Information** menu command.

Figure 5-6 shows the PLC Information dialog box that displays the error code and the description of the error.

The Last Fatal field shows the previous fatal error code generated by the S7-200. This value is retained over power cycles if the RAM is retained. This location is cleared either whenever all memory of the S7-200 is cleared or if the RAM is not retained after a prolonged power outage.

The Total Fatal field is the count of fatal errors generated by the S7-200 since the last time the S7-200 had all memory areas cleared. This value is retained over power cycles if the RAM is retained. This location is cleared whenever all memory of the S7-200 is cleared, or when the RAM is not retained after a prolonged power outage.

Appendix C lists the S7-200 error codes, and Appendix D describes the special memory (SM) bits, which can be used for monitoring errors.

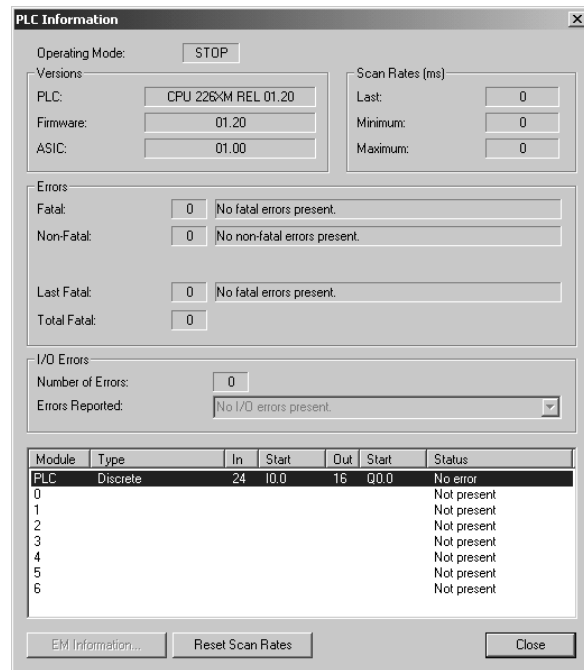

Figure 5-6 PLC Information Dialog Box

Non-Fatal Errors

Non-fatal errors are those indicating problems with the construction of the user program, with the execution of an instruction in the user program, and with expansion I/O modules. You can use STEP 7–Micro/WIN to view the error codes that were generated by the non-fatal error. There are three basic categories of non-fatal errors.

Program-compile errors

The S7-200 compiles the program as it downloads. If the S7-200 detects that the program violates a compilation rule, the download is aborted and an error code is generated. (A program that was already downloaded to the S7-200 would still exist in the EEPROM and would not be lost.) After you correct your program, you can download it again. Refer to Appendix C for a list of compile rule violations.

I/O errors

At startup, the S7-200 reads the I/O configuration from each module. During normal operation, the S7-200 periodically checks the status of each module and compares it against the configuration obtained during startup. If the S7-200 detects a difference, the S7-200 sets the configuration error bit in the module error register. The S7-200 does not read input data from or write output data to that module until the module configuration again matches the one obtained at startup.

The module status information is stored in special memory (SM) bits. Your program can monitor and evaluate these bits. Refer to Appendix D for more information about the SM bits used for reporting I/O errors. SM5.0 is the global I/O error bit and remains set while an error condition exists on an expansion module.

Program execution errors

Your program can create error conditions while being executed. These errors can result from improper use of an instruction or from the processing of invalid data by an instruction. For example, an indirect-address pointer that was valid when the program compiled could be modified during the execution of the program to point to an out-of-range address. This is an example of a run-time programming problem. SM4.3 is set upon the occurrence of a run-time programming problem and remains set while the S7-200 is in RUN mode. (Refer to Appendix C for the list of run-time programming problems). Program execution error information is stored in special memory (SM) bits. Your program can monitor and evaluate these bits. Refer to Appendix D for more information about the SM bits used for reporting program execution errors.

The S7-200 does not change to STOP mode when it detects a non-fatal error. It only logs the event in SM memory and continues with the execution of your program. However, you can design your program to force the S7-200 to STOP mode when a non-fatal error is detected. The following sample program shows a network of a program that is monitoring two of the global non-fatal error bits and changes the S7-200 to STOP whenever either of these bits turns on.

Sample Program: Logic for Detecting a Non-Fatal Error Condition	
	<pre> Network 1 //When an I/O error or a run-time error occurs, go to STOP mode LD SM5.0 O SM4.3 STOP </pre>

Fatal Errors

Fatal errors cause the S7-200 to stop the execution of your program. Depending upon the severity of the fatal error, it can render the S7-200 incapable of performing any or all functions. The objective for handling fatal errors is to bring the S7-200 to a safe state from which the S7-200 can respond to interrogations about the existing error conditions. When a fatal error is detected, the S7-200 changes to STOP mode, turns on the System Fault LED and the STOP LED, overrides the output table, and turns off the outputs. The S7-200 remains in this condition until the fatal error condition is corrected.

Once you have made the changes to correct the fatal error condition, use one of the following methods to restart the S7-200:

- Turn the power off and then on.
- Change the mode switch from RUN or TERM to STOP.
- Select the **PLC > Power-Up Reset** menu command from STEP 7–Micro/WIN to restart the S7-200. This forces the S7-200 to restart and clear any fatal errors.

Restarting the S7-200 clears the fatal error condition and performs power-up diagnostic testing to verify that the fatal error has been corrected. If another fatal error condition is found, the S7-200 again sets the fault LED, indicating that an error still exists. Otherwise, the S7-200 begins normal operation.

Some error conditions can render the S7-200 incapable of communication. In these cases, you cannot view the error code from the S7-200. These types of errors indicate hardware failures that require the S7-200 to be repaired; they cannot be fixed by changes to the program or clearing the memory of the S7-200.

Assigning Addresses and Initial Values in the Data Block Editor

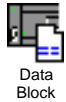

The data block editor allows you to make initial data assignments to V memory (variable memory) only. You can make assignments to bytes, words, or double words of V memory. Comments are optional.

The data block editor is a free-form text editor; that is, no specific fields are defined for particular types of information. After you finish typing a line and press the Enter key, the data block editor formats the line (aligns columns of addresses, data, comments; capitalizes V memory addresses) and redisplay it. The data block editor assigns an appropriate amount of V memory based on your previous address allocations and the size (byte, word, or double word) of the data value(s).



Figure 5-7 Data Block Editor

The first line of the data block must have an explicit address assignment. Subsequent lines can have explicit or implicit address assignments. An implicit address assignment is made by the editor when you type multiple data values after a single address assignment, or type a line that contains only data values.

The data block editor accepts uppercase or lowercase letters and allows commas, tabs, or spaces to serve as separators between addresses and data values.

Using the Symbol Table for Symbolic Addressing of Variables



The symbol table allows you to define and edit the symbols that can be accessed by the symbolic name anywhere in your program. You can create multiple symbol tables. There is also a tab in the symbol table for system-defined symbols that you can use in your program. The symbol table is also referred to as the global variable table.

You can identify the operands of the instructions in your program absolutely or symbolically. An absolute reference uses the memory area and bit or byte location to identify the address. A symbolic reference uses a combination of alphanumeric characters to identify the address.

For SIMATIC programs, you make global symbol assignments by using the symbol table. For IEC programs, you make global symbol assignments by using the global variable table.

To assign a symbol to an address:

1. Click on the Symbol Table icon in the navigation bar to open the symbol table.
2. Enter the symbol name (for example, Input1) in the Symbol Name column. The maximum symbol length is 23 characters.
3. Enter the address (for example, I0.0) in the Address column.
4. For an IEC global variable table, enter a value in the Data Type column or select one from the listbox.

	Symbol	Address	Comment
1	AlwaysOn	SM0.0	Always on contact
2	Pump1	Q2.3	Pump 1 on/off
3	Pump1Limit	I1.1	Pump 1 pressure limit switch
4	Pump1Pressure	VD100	Pump 1 current pressure (real)
5	Pump1Rpm	Vw200	Pump1 PRMs (integer)
6			

Figure 5-8 Symbol Table

You can create multiple symbol tables; however, you cannot use the same string more than once as a global symbol assignment, neither within a single table nor among several tables.

Using Local Variables

You can use the local variable table of the program editor to assign variables that are unique to an individual subroutine or interrupt routine. See Figure 5-9.

Local variables can be used as parameters that are passed in to a subroutine and they increase the portability or reuse of a subroutine.

Name	Var Type	Data Type	Comment
L00	IN	BOOL	Feed pass flag
L01	IN	BYTE	Address of slave device
L02	IN	INT	Choke to valve to drive
L03	IN/OUT	BYTE	Status of valve
L04	Done	BOOL	Done flag
L05	Error	WORD	Error number if any

Figure 5-9 Local Variable Table

Using the Status Chart to Monitor Your Program



Status Chart

A status chart allows you to monitor or modify the values of the process variables as your S7-200 runs the control program. You can track the status of program inputs, outputs, or variables by displaying the current values. The status chart also allows you to force or change the values of the process variables.

You can create multiple status charts in order to view elements from different portions of your program.

To access the status chart, select the **View > Component > Status Chart** menu command or click the Status Chart icon in the navigation bar.

When you create a status chart, you enter addresses of process variables for monitoring. You cannot view the status of constants, accumulators, or local variables. You can display a timer or counter value either as a bit or as a word. Displaying the value as a bit shows the status of the timer or counter bit; displaying the value as a word shows the timer or counter value.

Address	Format	Normal Value	User Value
Input	Bit	0	
Input Word	Word	0	
Input Register	Word	0	
Input Register	Word	0	
Output	Bit	0	
Output	Word	0	
Timer	Timer	0	
Counter	Counter	0	

Figure 5-10 Status Chart

To build a status chart and monitor the variables:

1. Enter the address for each desired value in the Address field.
2. Select the data type in the Format column.
3. To view the status of the process variables in your S7-200, select the **Debug > Chart Status** menu command.
4. To continuously sample the values, or to perform a single read of the status, click the button on the toolbar. The Status Chart also allows you to modify or force values for the different process variables.

You can insert additional rows in your Status Chart by selecting the **Edit > Insert > Row** menu command.



Tip

You can create multiple status charts to divide the variables into logical groups so that each group can be viewed in a shorter and separate status chart.

Creating an Instruction Library

STEP 7–Micro/WIN allows you either to create a custom library of instructions, or to use a library created by someone else. See Figure 5-11.

To create a library of instructions, you create standard STEP 7–Micro/WIN subroutine and interrupt routines and group them together. You can hide the code in these routines to prevent accidental changes or to protect the technology (know-how) of the author.

To create an instruction library, perform the following tasks:

1. Write the program as a standard STEP 7–Micro/WIN project and put the function to be included in the library into subroutines or interrupt routines.
2. Ensure that all V memory locations in the subroutines or interrupt routines have been assigned a symbolic name. To minimize the amount of V memory that the library requires, use sequential V memory locations.
3. Rename the subroutines or interrupt routines to the names that you want to appear in the instruction library.
4. Select the **File > Create Library** menu command to compile the new instruction library.

For more information about creating libraries, refer to the online help for STEP 7–Micro/WIN.

Use the following procedure to access an instruction in an instruction library:

1. Add the Libraries directory to the instruction tree by selecting the **File > Add Libraries** menu command.
2. Select the specific instruction and insert it into your program (as you would any standard instruction).

If the library routine requires any V memory, STEP 7–Micro/WIN prompts you when the project is compiled to assign a block of memory. Use the Library Memory Allocation dialog box to assign blocks of memory.

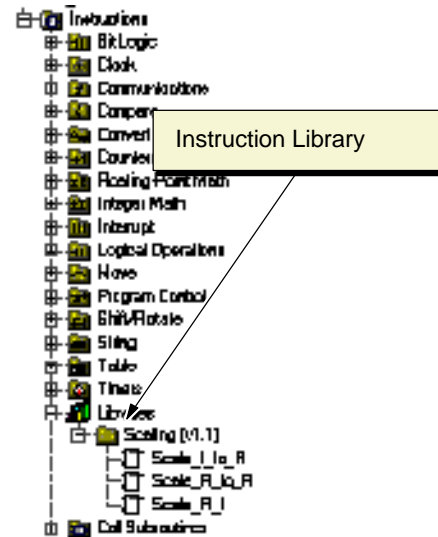

Figure 5-11 Instruction Tree with Libraries

Features for Debugging Your Program

STEP 7–Micro/WIN provides the following features to help you debug your program:

- Bookmarks in your program to make it easy to move back and forth between lines of a long program.
- Cross Reference table allow you to check the references used in your program.
- RUN-mode editing allows you to make small changes to your program with minimal disturbance to the process controlled by the program. You can also download the program block when you are editing in RUN mode.

For more information about debugging your program, refer to Chapter 8.

S7-200 Instruction Set

6

This chapter describes the SIMATIC and IEC 1131 instruction set for the S7-200 Micro PLCs.

In This Chapter

Conventions Used to Describe the Instructions	63
S7-200 Memory Ranges and Features	64
Bit Logic Instructions	66
Contacts	66
Coils	68
Logic Stack Instructions	70
Set and Reset Dominant Bistable Instructions	72
Clock Instructions	73
Communications Instructions	74
Network Read and Network Write Instructions	74
Transmit and Receive Instructions (Freeport)	79
Get Port Address and Set Port Address Instructions	88
Compare Instructions	89
Comparing Numerical Values	89
Compare String	91
Conversion Instructions	92
Standard Conversion Instructions	92
ASCII Conversion Instructions	96
String Conversion Instructions	100
Encode and Decode Instructions	105
Counter Instructions	106
SIMATIC Counter Instructions	106
IEC Counter Instructions	109
High-Speed Counter Instructions	111
Pulse Output Instruction	125
Math Instructions	140
Add, Subtract, Multiply, and Divide Instructions	140
Multiply Integer to Double Integer and Divide Integer with Remainder	142
Numeric Functions Instructions	143
Increment and Decrement Instructions	144
Proportional/Integral/Derivative (PID) Loop Instruction	145
Interrupt Instructions	155
Logical Operations Instructions	162
Invert Instructions	162
AND, OR, and Exclusive OR Instructions	163
Move Instructions	165
Move Byte, Word, Double Word, or Real	165
Move Byte Immediate (Read and Write)	166
Block Move Instructions	167

Program Control Instructions	168
Conditional End	168
Stop	168
Watchdog Reset	168
For–Next Loop Instructions	170
Jump Instructions	172
Sequence Control Relay (SCR) Instructions	173
Shift and Rotate Instructions	179
Shift Right and Shift Left Instructions	179
Rotate Right and Rotate Left Instructions	179
Shift Register Bit Instruction	181
Swap Bytes Instruction	183
String Instructions	184
Table Instructions	189
Add To Table	189
First-In-First-Out and Last-In-First-Out	190
Memory Fill	192
Table Find	193
Timer Instructions	196
SIMATIC Timer Instructions	196
IEC Timer Instructions	201
Subroutine Instructions	203

Conventions Used to Describe the Instructions

Figure 6-1 shows a typical description for an instruction and points to the different areas used to describe the instruction and its operation. The illustration of the instruction shows the format in LAD, FBD, and STL. The operand table lists the operands for the instruction and shows the valid data types, memory areas and sizes for each operand.

EN/ENO operands and data types are not shown in the instruction operand table because the operands are the same for all LAD and FBD instructions.

- For LAD: EN and ENO are power flow and are BOOL data types.
- For FBD: EN and ENO are I, Q, V, M, SM, S, T, C, L, or power flow and are BOOL data types.

Description of the instruction and operands

STL instruction

LAD and FBD instructions

Transmit and Receive Instructions

The Transmit instruction (XMT) is used in Freepoint mode to transmit data by means of the communication port(s).

The Receive instruction (RCV) initiates or terminates the Receive Message service. You must specify a start and an end condition for the Receive box to operate. Messages received through the specified port (PORT) are stored in the data buffer (TBL). The first entry in the data buffer specifies the number of bytes received.

Error conditions that set ENO = 0

- SM86.6 or SM186.6 error bit set (RCV parameter error)
- 0006 (indirect address)
- 0009 (simultaneous XMT/RCV on port 0)
- 000B (simultaneous XMT/RCV on port 1)
- S7-200 CPU not in Freepoint mode

Inputs/Outputs	Data Type	Operands
TBL	BYTE	VB, IB, QB, MB, SB, SMB, *VD, *AC, *LD
PORT	BYTE	Constant for CPU 221, CPU 222, CPU 224: 0 for CPU 225 and CPU 225X/A: 0 or 1

Using Freepoint Mode to Control the Serial Communication Port

You can select the Freepoint mode to control the serial communication port of the S7-200 by means of the program. When you select Freepoint mode, your program controls the operation of the communication port. When you use the receive/interrupts, the transmit interrupts, the Transmit instruction, and the Receive instruction, the communication protocol is entirely controlled by the ladder program while in Freepoint mode. SMB30 (for port 0) and SMB130 (for port 1) if your S7-200 has two ports are used to control the baud rate and parity.

The Freepoint mode is disabled and normal communication is re-established (for example, programming device connection) when the S7-200 is in the STOP mode.

Freeport communication is possible only when the S7-200 is in the RUN mode. Enable the Freepoint mode by setting a value of 01 in the protocol select field of SMB30 (Port 0) or SMB130 (Port 1). While in Freepoint mode, communication with the programming device is not possible.

Tip
Entering Freepoint mode can be controlled using special memory bit SM0.7, which reflects the current position of the operating mode switch. When SM0.7 is equal to 0, the switch is in TERM position; when SM0.7 = 1, the operating mode switch is in RUN position. If you enable Freepoint mode only when the switch is in RUN position, you can use the programming device to monitor or control the S7-200 operation by changing the switch to any other position.

List of the error conditions that affect ENO and any SM bits affected

Operands for the instruction

Valid data types

Valid memory areas and sizes for the operands

6

Figure 6-1 Instruction Descriptions

S7-200 Memory Ranges and Features

Table 6-1 Memory Ranges and Features for the S7-200 CPUs

Description	CPU 221	CPU 222	CPU 224	CPU 226	CPU 226XM
User program size	2 Kwords	2 Kwords	4 Kwords	4 Kwords	8 Kwords
User data size	1 Kwords	1 Kwords	2.5 Kwords	2.5 Kwords	5 Kwords
Process-image input register	I0.0 to I15.7	I0.0 to I15.7	I0.0 to I15.7	I0.0 to I15.7	I0.0 to I15.7
Process-image output register	Q0.0 to Q15.7	Q0.0 to Q15.7	Q0.0 to Q15.7	Q0.0 to Q15.7	Q0.0 to Q15.7
Analog inputs (read only)	—	AIW0 to AIW30	AIW0 to AIW62	AIW0 to AIW62	AIW0 to AIW62
Analog outputs (write only)	—	AQW0 to AQW30	AQW0 to AQW62	AQW0 to AQW62	AQW0 to AQW62
Variable memory (V)	VB0 to VB2047	VB0 to VB2047	VB0 to VB5119	VB0 to VB5119	VB0 to VB10239
Local memory (L) ¹	LB0 to LB63	LB0 to LB63	LB0 to LB63	LB0 to LB63	LB0 to LB63
Bit memory (M)	M0.0 to M31.7	M0.0 to M31.7	M0.0 to M31.7	M0.0 to M31.7	M0.0 to M31.7
Special Memory (SM) Read only	SM0.0 to SM179.7 SM0.0 to SM29.7	SM0.0 to SM299.7 SM0.0 to SM29.7	SM0.0 to SM549.7 SM0.0 to SM29.7	SM0.0 to SM549.7 SM0.0 to SM29.7	SM0.0 to SM549.7 SM0.0 to SM29.7
Timers	256 (T0 to T255)	256 (T0 to T255)	256 (T0 to T255)	256 (T0 to T255)	256 (T0 to T255)
Retentive on-delay	1 ms T0, T64	T0, T64	T0, T64	T0, T64	T0, T64
	10 ms T1 to T4, and T65 to T68	T1 to T4, and T65 to T68	T1 to T4, and T65 to T68	T1 to T4, and T65 to T68	T1 to T4, and T65 to T68
	100 ms T5 to T31, and T69 to T95	T5 to T31, and T69 to T95	T5 to T31, and T69 to T95	T5 to T31, and T69 to T95	T5 to T31, and T69 to T95
On/Off delay	1 ms T32, T96	T32, T96	T32, T96	T32, T96	T32, T96
	10 ms T33 to T36, and T97 to T100	T33 to T36, and T97 to T100	T33 to T36, and T97 to T100	T33 to T36, and T97 to T100	T33 to T36, and T97 to T100
	100 ms T37 to T63, and T101 to T255	T37 to T63, and T101 to T255	T37 to T63, and T101 to T255	T37 to T63, and T101 to T255	T37 to T63, and T101 to T255
Counters	C0 to C255	C0 to C255	C0 to C255	C0 to C255	C0 to C255
High-speed counters	HC0, HC3, HC4, and HC5	HC0, HC3, HC4, and HC5	HC0 to HC5	HC0 to HC5	HC0 to HC5
Sequential control relays (S)	S0.0 to S31.7	S0.0 to S31.7	S0.0 to S31.7	S0.0 to S31.7	S0.0 to S31.7
Accumulator registers	AC0 to AC3	AC0 to AC3	AC0 to AC3	AC0 to AC3	AC0 to AC3
Jumps/Labels	0 to 255	0 to 255	0 to 255	0 to 255	0 to 255
Call/Subroutine	0 to 63	0 to 63	0 to 63	0 to 63	0 to 127
Interrupt routines	0 to 127	0 to 127	0 to 127	0 to 127	0 to 127
Positive/negative transitions	256	256	256	256	256
PID loops	0 to 7	0 to 7	0 to 7	0 to 7	0 to 7
Ports	Port 0	Port 0	Port 0	Port 0, Port 1	Port 0, Port 1

¹ LB60 to LB63 are reserved by STEP 7–Micro/WIN, version 3.0 or later.

Table 6-2 Operand Ranges for the S7-200 CPUs

Access Method		CPU 221	CPU 222	CPU 224, CPU 226	CPU 226XM
Bit access (byte.bit)	I	0.0 to 15.7	0.0 to 15.7	0.0 to 15.7	0.0 to 15.7
	Q	0.0 to 15.7	0.0 to 15.7	0.0 to 15.7	0.0 to 15.7
	V	0.0 to 2047.7	0.0 to 2047.7	0.0 to 5119.7	0.0 to 10239.7
	M	0.0 to 31.7	0.0 to 31.7	0.0 to 31.7	0.0 to 31.7
	SM	0.0 to 179.7	0.0 to 299.7	0.0 to 549.7	0.0 to 549.7
	S	0.0 to 31.7	0.0 to 31.7	0.0 to 31.7	0.0 to 31.7
	T	0 to 255	0 to 255	0 to 255	0 to 255
	C	0 to 255	0 to 255	0 to 255	0 to 255
	L	0.0 to 59.7	0.0 to 59.7	0.0 to 59.7	0.0 to 59.7
Byte access	IB	0 to 15	0 to 15	0 to 15	0 to 15
	QB	0 to 15	0 to 15	0 to 15	0 to 15
	VB	0 to 2047	0 to 2047	0 to 5119	0 to 10239
	MB	0 to 31	0 to 31	0 to 31	0 to 31
	SMB	0 to 179	0 to 299	0 to 549	0 to 549
	SB	0 to 31	0 to 31	0 to 31	0 to 31
	L	0 to 63	0 to 63	0 to 63	0 to 255
	AC	0 to 3	0 to 3	0 to 3	0 to 255
Word access	IW	0 to 14	0 to 14	0 to 14	0 to 14
	QW	0 to 14	0 to 14	0 to 14	0 to 14
	VW	0 to 2046	0 to 2046	0 to 5118	0 to 10238
	MW	0 to 30	0 to 30	0 to 30	0 to 30
	SMW	0 to 178	0 to 298	0 to 548	0 to 548
	SW	0 to 30	0 to 30	0 to 30	0 to 30
	T	0 to 255	0 to 255	0 to 255	0 to 255
	C	0 to 255	0 to 255	0 to 255	0 to 255
	LW	0 to 58	0 to 58	0 to 58	0 to 58
	AC	0 to 3	0 to 3	0 to 3	0 to 3
	AIW	None	0 to 30	0 to 62	0 to 62
	AQW	None	0 to 30	0 to 62	0 to 62
Double word access	ID	0 to 12	0 to 12	0 to 12	0 to 12
	QD	0 to 12	0 to 12	0 to 12	0 to 12
	VD	0 to 2044	0 to 2044	0 to 5116	0 to 10236
	MD	0 to 28	0 to 28	0 to 28	0 to 28
	SMD	0 to 176	0 to 296	0 to 546	0 to 546
	SD	0 to 28	0 to 28	0 to 28	0 to 28
	LD	0 to 56	0 to 56	0 to 56	0 to 56
	AC	0 to 3	0 to 3	0 to 3	0 to 3
	HC	0, 3, 4, 5	0, 3, 4, 5	0 to 5	0 to 5

Bit Logic Instructions

Contacts

Standard Contacts

The Normally Open contact instructions (LD, A, and O) and Normally Closed contact instructions (LDN, AN, ON) obtain the referenced value from the memory or from the process-image register. The standard contact instructions obtain the referenced value from the memory (or process-image register if the data type is I or Q).

The Normally Open contact is closed (on) when the bit is equal to 1, and the Normally Closed contact is closed (on) when the bit is equal to 0. In FBD, inputs to both the And and Or boxes can be expanded to a maximum of 32 inputs. In STL, the Normally Open instructions Load, AND, or OR the bit value of the address bit to the top of the stack, and the Normally Closed instructions Load, AND, or OR the logical NOT of the bit value to the top of the stack.

Immediate Contacts

An immediate contact does not rely on the S7-200 scan cycle to update; it updates immediately. The Normally Open Immediate contact instructions (LDI, AI, and OI) and Normally Closed Immediate contact instructions (LDNI, ANI, and ONI) obtain the physical input value when the instruction is executed, but the process-image register is not updated.

The Normally Open Immediate contact is closed (on) when the physical input point (bit) is 1, and the Normally Closed Immediate contact is closed (on) when the physical input point (bit) is 0. The Normally Open instructions immediately Load, AND, or OR the physical input value to the top of the stack, and the Normally Closed instructions immediately Load, AND, or OR the logical NOT of the value of the physical input point to the top of the stack.

NOT Instruction

The Not instruction (NOT) changes the state of power flow input (that is, it changes the value on the top of the stack from 0 to 1 or from 1 to 0).

Positive and Negative Transition Instructions

The Positive Transition contact instruction (EU) allows power to flow for one scan for each off-to-on transition. The Negative Transition contact instruction (ED) allows power to flow for one scan for each on-to-off transition. For the Positive Transition instruction, detection of a 0-to-1 transition in the value on the top of the stack sets the top of the stack value to 1; otherwise, it is set to 0. For a Negative Transition instruction, detection of a 1-to-0 transition in the value on the top of the stack sets the top of the stack value to 1; otherwise, it is set to 0.

For run-time editing (when you edit your program in RUN mode), you must enter a parameter for the Positive Transition and Negative Transition instructions. Refer to Chapter 5 for more information about editing in RUN mode.

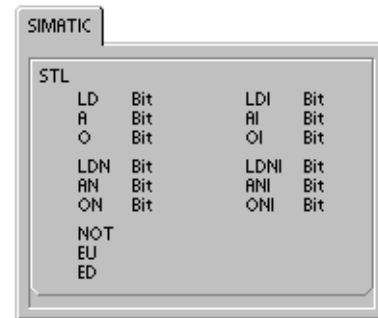
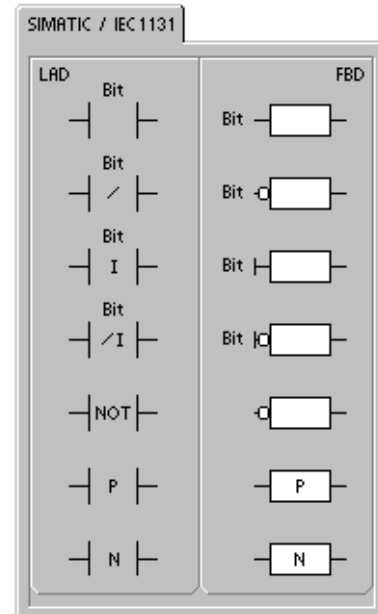

Table 6-3 Valid Operands for the Bit Logic Input Instructions

Inputs/Outputs	Data Type	Operands
Bit	BOOL	I, Q, V, M, SM, S, T, C, L, Power Flow
Bit (immediate)	BOOL	I



Tip

Because the Positive Transition and Negative Transition instructions require an on-to-off or an off-to-on transition, you cannot detect an edge-up or edge-down transition on the first scan. During the first scan, the S7-200 sets the state of the bit specified by these instructions. On subsequent scans, these instructions can then detect transitions for the specified bit.

Example: Contact Instructions

<p>Network 1</p> <p>Network 2</p> <p>Network 3</p>	<p>Network 1 //N.O. contacts I0.0 AND I0.1 must be on (closed) to activate //Q0.0. The NOT instruction acts as an inverter. //In RUN mode, Q0.0 and Q0.1 have opposite logic states.</p> <pre>LD I0.0 A I0.1 = Q0.0 NOT = Q0.1</pre> <p>Network 2 //N.O. contact I0.2 must be on or N.C. contact I0.3 must be off //to activate Q0.2. One or more parallel LAD branches //(OR logic inputs) must be true to make the output active.</p> <pre>LD I0.2 ON I0.3 = Q0.2</pre> <p>Network 3 //A positive Edge Up input on a P contact or a negative Edge //Down input on a N contact outputs a pulse with a 1 scan cycle //duration. In RUN mode, the pulsed state changes of Q0.4 and //Q0.5 are too fast to be visible in program status view. //The Set and Reset outputs latch the pulse in Q0.3 and //make the state change visible in program status view.</p> <pre>LD I0.4 LPS EU S Q0.3, 1 = Q0.4 LPP ED R Q0.3, 1 = Q0.5</pre>
---	--

Timing Diagram

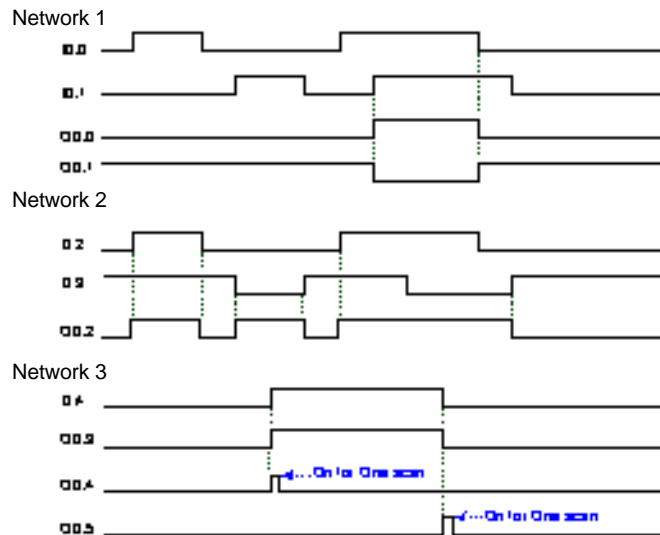

Coils

Output

The Output instruction (=) writes the new value for the output bit to the process-image register. When the Output instruction is executed, the S7-200 turns the output bit in the process-image register on or off. For LAD and FBD, the specified bit is set equal to power flow. For STL, the value on the top of the stack is copied to the specified bit.

Output Immediate

The Output Immediate instruction (=I) writes the new value to both the physical output and the corresponding process-image register location when the instruction is executed.

When the Output Immediate instruction is executed, the physical output point (Bit) is immediately set equal to power flow. For STL, the instruction immediately copies the value on the top of the stack to the specified physical output bit (STL). The "I" indicates an immediate reference; the new value is written to both the physical output and the corresponding process-image register location when the instruction is executed. This differs from the non-immediate references, which write the new value to the process-image register only.

Set and Reset

The Set (S) and Reset (R) instructions set (turn on) or reset (turn off) the specified number of points (N), starting at the specified address (Bit). You can set or reset from 1 to 255 points.

If the Reset instruction specifies either a timer bit (T) or counter bit (C), the instruction resets the timer or counter bit and clears the current value of the timer or counter.

Error conditions that set ENO = 0

- 0006 (indirect address)
- 0091 (operand out of range)

Set Immediate and Reset Immediate

The Set Immediate and Reset Immediate instructions immediately set (turn on) or immediately reset (turn off) the number of points (N), starting at specified address (Bit). You can set or reset from 1 to 128 points immediately.

The "I" indicates an immediate reference; when the instruction is executed, the new value is written to both the physical output point and the corresponding process-image register location. This differs from the non-immediate references, which write the new value to the process-image register only.

Error conditions that set ENO = 0

- 0006 (indirect address)
- 0091 (operand out of range)

Table 6-4 Valid Operands for the Bit Logic Output Instructions

Inputs/Outputs	Data Type	Operands
Bit	BOOL	I, Q, V, M, SM, S, T, C, L
Bit (immediate)	BOOL	Q
N	BYTE	IB, QB, VB, MB, SMB, SB, LB, AC, *VD, *LD, *AC, Constant

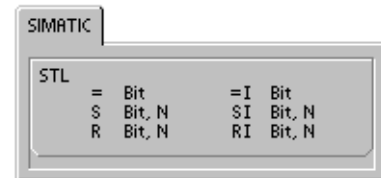
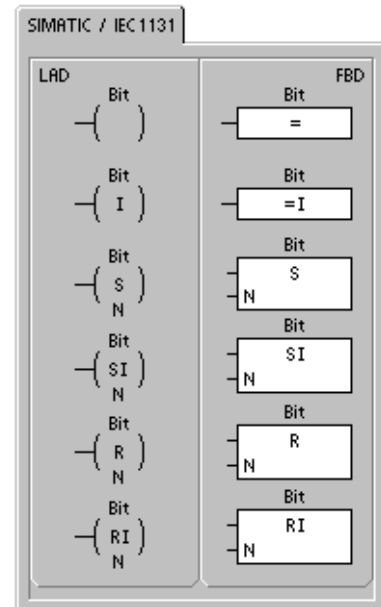

Example: Coil Instructions

<p>Network 1</p> <p>Network 2</p> <p>Network 3</p> <p>Network 4</p> <p>Network 5</p>	<p>Network 1 //Output instructions assign bit values to external I/O (I, Q) //and internal memory (M, SM, T, C, V, S, L).</p> <pre>LD I0.0 = Q0.0 = Q0.1 = V0.0</pre> <p>Network 2 //Set a sequential group of 6 bits to a value of 1. //Specify a starting bit address and how many bits to set. //The program status indicator for Set is ON when the value //of the first bit (Q0.2) is 1.</p> <pre>LD I0.1 S Q0.2, 6</pre> <p>Network 3 //Reset a sequential group of 6 bits to a value of 0. //Specify a starting bit address and how many bits to reset. //The program status indicator for Reset is ON when the value //of the first bit (Q0.2) is 0.</p> <pre>LD I0.2 R Q0.2, 6</pre> <p>Network 4 //Sets and resets 8 output bits (Q1.0 to Q1.7) as a group.</p> <pre>LD I0.3 LPS A I0.4 S Q1.0, 8 LPP A I0.5 R Q1.0, 8</pre> <p>Network 5 //The Set and Reset instructions perform the function of a latched relay. //To isolate the Set/Reset bits, make sure they are not overwritten by //another assignment instruction. In this example, Network 4 sets and //resets eight output bits (Q1.0 to Q1.7) as a group. //In RUN mode, Network 5 can overwrite the Q1.0 bit value and //control the Set/Reset program status indicators in Network 4.</p> <pre>LD I0.6 = Q1.0</pre>
---	--

Timing Diagram

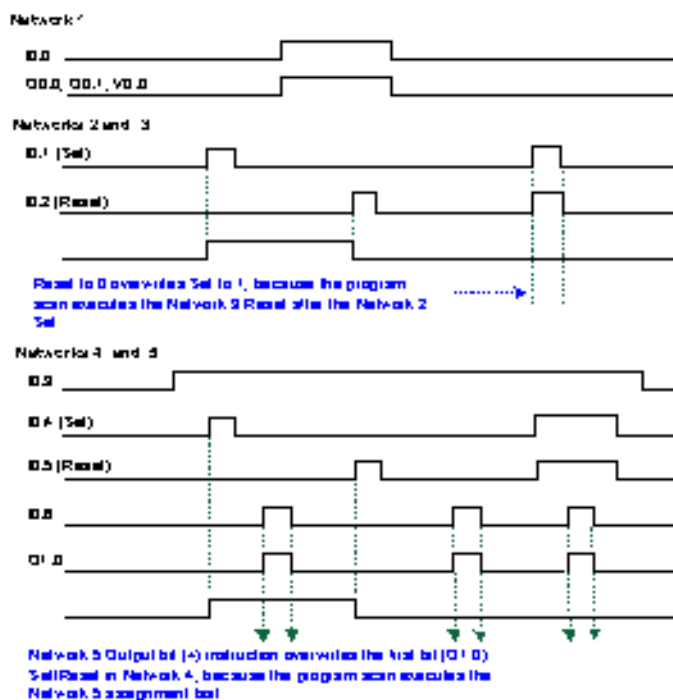

Logic Stack Instructions

AND Load

The AND Load instruction (ALD) combines the values in the first and second levels of the stack using a logical AND operation. The result is loaded in the top of stack. After the ALD is executed, the stack depth is decreased by one.

OR Load

The OR Load instruction (OLD) combines the values in the first and second levels of the stack, using a logical OR operation. The result is loaded in the top of the stack. After the OLD is executed, the stack depth is decreased by one.

Logic Push

The Logic Push instruction (LPS) duplicates the top value on the stack and pushes this value onto the stack. The bottom of the stack is pushed off and lost.

Logic Read

The Logic Read instruction (LRD) copies the second stack value to the top of stack. The stack is not pushed or popped, but the old top-of-stack value is destroyed by the copy.

Logic Pop

The Logic Pop instruction (LPP) pops one value off of the stack. The second stack value becomes the new top of stack value.

AND ENO

The AND ENO instruction (AENO) performs a logical AND of the ENO bit with the top of the stack to generate the same effect as the ENO bit of a box in LAD or FBD. The result of the AND operation is the new top of stack.

ENO is a Boolean output for boxes in LAD and FBD. If a box has power flow at the EN input and is executed without error, the ENO output passes power flow to the next element. You can use the ENO as an enable bit that indicates the successful completion of an instruction. The ENO bit is used with the top of stack to affect power flow for execution of subsequent instructions. STL instructions do not have an EN input. The top of the stack must be a logic 1 for conditional instructions to be executed. In STL there is also no ENO output. However, the STL instructions that correspond to LAD and FBD instructions with ENO outputs set a special ENO bit. This bit is accessible with the AENO instruction.

Load Stack

The Load Stack instruction (LDS) duplicates the stack bit (N) on the stack and places this value on top of the stack. The bottom of the stack is pushed off and lost.

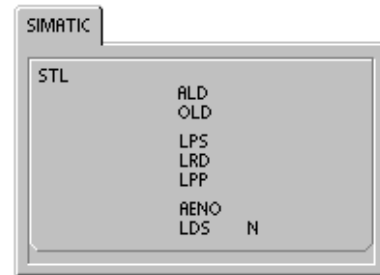

6

Table 6-5 Valid Operands for the Load Stack Instruction

Inputs/Outputs	Data Type	Operands
N	BYTE	Constant (0 to 8)

As shown in Figure 6-2, the S7-200 uses a logic stack to resolve the control logic. In these examples, "iv0" to "iv7" identify the initial values of the logic stack, "nv" identifies a new value provided by the instruction, and "S0" identifies the calculated value that is stored in the logic stack.

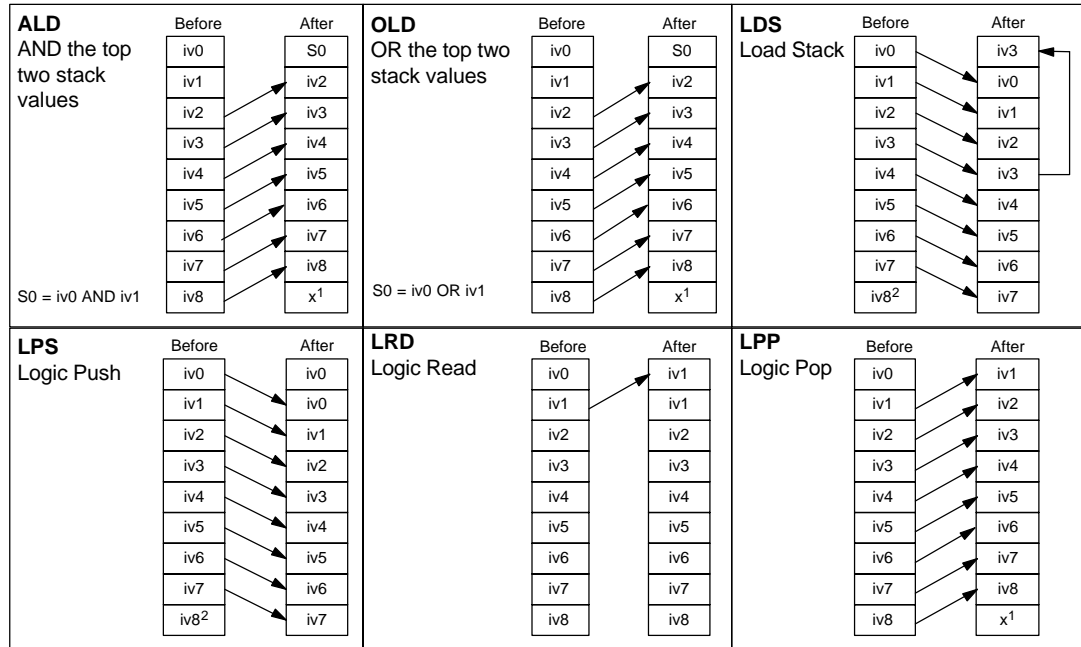

- 1 The value is unknown (it could be either a 0 or a 1).
- 2 After the execution of a Logic Push or a Load Stack instruction, value iv8 is lost.

Figure 6-2 Operations of the Logic Stack Instructions

Example: Logic Stack Instructions	
<p>Network 1</p> <p>Network 2</p>	<p>Network 1</p> <pre>LD I0.0 LD I0.1 LD I2.0 A I2.1 = Q5.0</pre> <p>Network 2</p> <pre>LD I0.0 LPS LD I0.5 O I0.6 ALD = Q7.0 LRD LD I2.1 O I1.3 ALD = Q6.0 LPP A I1.0 = Q3.0</pre>

Set and Reset Dominant Bistable Instructions

The Set Dominant Bistable is a latch where the set dominates. If the set (S1) and reset (R) signals are both true, the output (OUT) is true.

The Reset Dominant Bistable is a latch where the reset dominates. If the set (S) and reset (R1) signals are both true, the output (OUT) is false.

The Bit parameter specifies the Boolean parameter that is set or reset. The optional output reflects the signal state of the Bit parameter.

Table 6-7 shows the truth tables for the sample program.

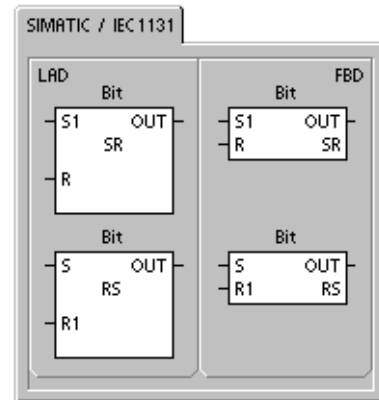

Table 6-6 Valid Operands for the Set Dominant Bistable and Reset Dominant Bistable Instructions

Inputs/Outputs	Data Types	Operands
S1, R	BOOL	I, Q, V, M, SM, S, T, C, Power Flow
S, R1, OUT	BOOL	I, Q, V, M, SM, S, T, C, L, Power Flow
Bit	BOOL	I, Q, V, M, S

Example: Set and Reset Dominant Bistable Instructions

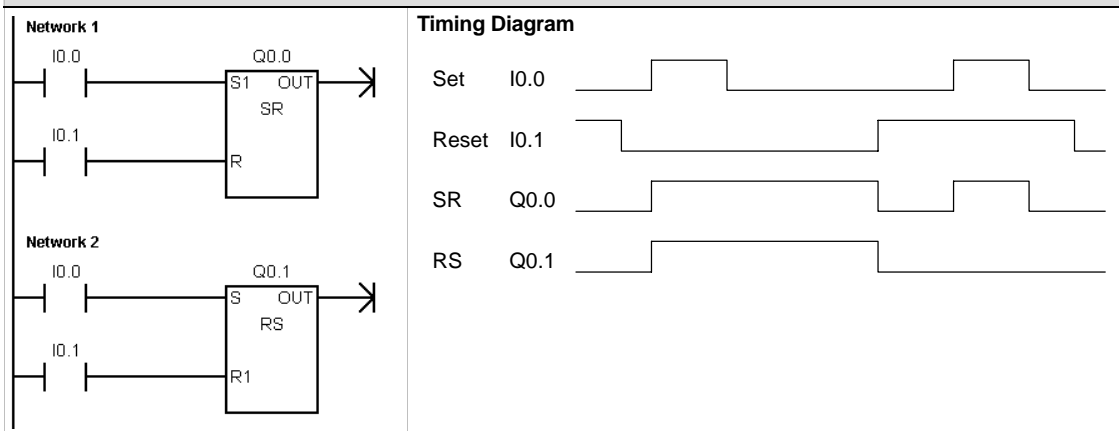

Table 6-7 Truth Table for the Set and Reset Dominant Bistable Instructions

Instruction	S1	R	Out (Bit)
Set Dominant Bistable instruction (SR)	0	0	Previous state
	0	1	0
	1	0	1
	1	1	1
Instruction	S	R1	Out (Bit)
Reset Dominant Bistable instruction (RS)	0	0	Previous state
	0	1	0
	1	0	1
	1	1	0

Clock Instructions

Read Real-Time Clock and Set Real-Time Clock

The Read Real-Time Clock (TODR) instruction reads the current time and date from the hardware clock and loads it in an 8-byte Time buffer starting at address T. The Set Real-Time Clock (TODW) instruction writes the current time and date to the hardware clock, beginning at the 8-byte Time buffer address specified by T.

You must code all date and time values in BCD format (for example, 16#97 for the year 1997). Figure 6-3 shows the format of the Time buffer (T).

The time-of-day (TOD) clock initializes the following date and time after extended power outages or when memory has been lost:

Date: 01–Jan–90
 Time: 00:00:00
 Day of Week: Sunday

Error conditions that set ENO = 0

- 0006 (indirect address)
- 0007 (TOD data error) *Set Real-Time Clock only*
- 000C (clock not present)

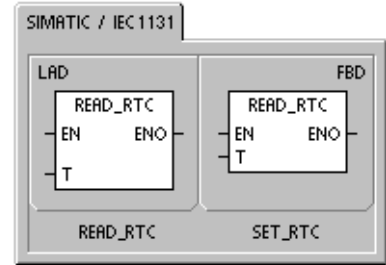

Table 6-8 Valid Operands for the Clock Instructions

Inputs/Outputs	Data Types	Operands
T	BYTE	IB, QB, VB, MB, SMB, SB, LB, *VD, *LD, *AC

T	T+1	T+2	T+3	T+4	T+5	T+6	T+7
Year: 00 to 99	Month: 01 to 12	Day: 01 to 31	Hours: 00 to 23	Minutes: 00 to 59	Seconds: 00 to 59	0	Day of Week: 0 to 7*

*T+7 1=Sunday, 7=Saturday
0 disables the day of week.

Figure 6-3 Format of the 8-Byte Time Buffer (T)



Tip

The S7-200 CPU does not perform a check to verify that the day of week is correct based upon the date. Invalid dates, such as February 30, could be accepted. You should ensure that the date you enter is correct.

Do not use the TODR/TODW instruction in both the main program and in an interrupt routine. A TODR/TODW instruction in an interrupt routine that attempts to execute while another TODR/TODW instruction is in process cannot be executed. SM4.3 is set indicating that two simultaneous accesses to the clock were attempted (non-fatal error 0007).

The time-of-day clock in the S7-200 uses only the least significant two digits for the year, so for the year 2000, the year is represented as 00. The S7-200 PLC does not use the year information in any way. However, user programs that use arithmetic or compares with the year's value must take into account the two-digit representation and the change in century.

Leap year is correctly handled through year 2096.

Communications Instructions

Network Read and Network Write Instructions

The Network Read instruction (NETR) initiates a communications operation to gather data from a remote device through the specified port (PORT), as defined by the table (TBL). The Network Write instruction (NETW) initiates a communications operation to write data to a remote device through the specified port (PORT), as defined by the table (TBL).

Error conditions that set ENO = 0:

- 0006 (indirect address)
- If the function returns an error and sets the E bit of table status byte (see Figure 6-4)

The Network Read instruction can read up to 16 bytes of information from a remote station, and the Network Write instruction can write up to 16 bytes of information to a remote station.

You can have any number of Network Read and Network Write instructions in the program, but only a maximum of eight Network Read and Network Write instructions can be activated at any one time. For example, you can have 4 Network Read and 4 Network Write instructions, or 2 Network Read and 6 Network Write instructions, active at the same time in a given S7-200.

You can use the Network Read/Network Write Instruction Wizard to configure the counter. To start the Network Read/Network Write Instruction Wizard, select the **Tools > Instruction Wizard** menu command and then select Network Read/Network Write from the Instruction Wizard window.

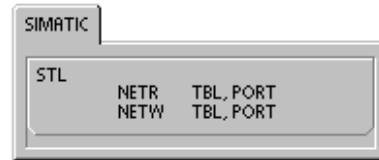
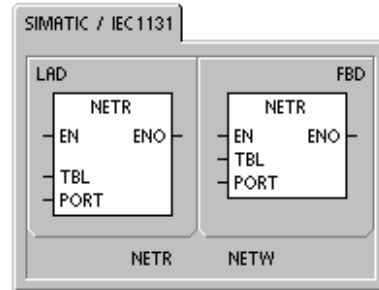

6



Instruction Wizard

Table 6-9 Valid Operands for the Network Read and Network Write Instructions

Inputs/Outputs	Data Type	Operands
TBL	BYTE	VB, MB, *VD, *LD, *AC
PORT	BYTE	Constant for CPU 221, CPU 222, CPU 224: 0 for CPU 226 and CPU 226XM: 0 or 1

Figure 6-4 describes the table that is referenced by the TBL parameter, and Table 6-10 lists the error codes.

Byte Offset	7	0	
0	D	A	E 0 Error code
1	Remote station address		Remote station address: the address of the PLC whose data is to be accessed.
2	Pointer to the data		Pointer to the data area in the remote station: an indirect pointer to the data that is to be accessed.
3	area in the		
4	remote station		
5	(I, Q, M, or V)		Data length: the number of bytes of data that are to be accessed in the remote station (1 to 16 bytes).
6	Data length		Receive or transmit data area. 1 to 16 bytes reserved for the data. For a Network Read instruction, stores the values that were read from the remote station when the instruction was executed. For a Network Write instruction, stores the values to be sent to the remote station when the instruction is executed.
7	Data byte 0		
8	Data byte 1		
	⋮		
	⋮		
	⋮		
22	Data byte 15		

Figure 6-4 TBL Parameter for the Network Read and Network Write Instructions

Table 6-10 Error Codes for the TBL Parameter

Code	Definition
0	No error.
1	Time-out error: Remote station not responding.
2	Receive error: Parity, framing, or checksum error in the response.
3	Offline error: Collisions caused by duplicate station addresses or failed hardware.
4	Queue overflow error: More than 8 Network Read or Network Write instructions have been activated.
5	Protocol violation: Attempt to execute a Network Read or Network Write instruction without enabling the PPI Master Mode in SMB30 or SMB130.
6	Illegal parameter: TBL parameter contains an illegal or invalid value.
7	No resource: Remote station is busy. (An upload or a download sequence is in process.)
8	Layer 7 error: Application protocol violation
9	Message error: Wrong data address or incorrect data length
A to F	Not used. (Reserved)

Figure 6-5 shows an example to illustrate the utility of the Network Read and Network Write instructions. For this example, consider a production line where tubs of butter are being filled and sent to one of four boxing machines (case packers). The case packer packs eight tubs of butter into a single cardboard box. A diverter machine controls the flow of butter tubs to each of the case packers. Four S7-200s control the case packers, and an S7-200 with a TD 200 operator interface controls the diverter.

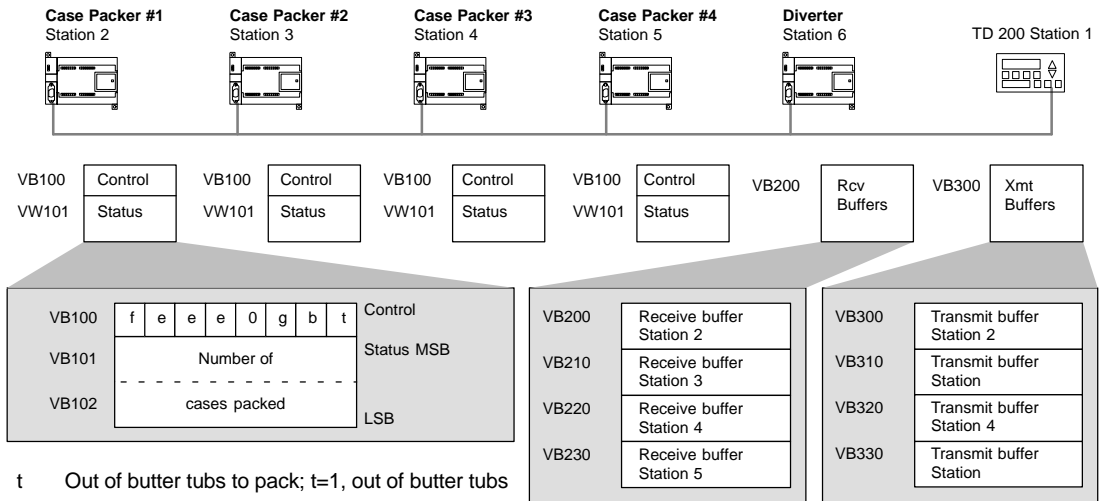

- t Out of butter tubs to pack; t=1, out of butter tubs
- b Box supply is low; b=1, must add boxes in the next 30 minutes
- g Glue supply is low; g=1, must add glue in the next 30 minutes
- eee error code identifying the type of fault experienced
- f Fault indicator; f=1, the case packer has detected an error

Figure 6-5 Example of the Network Read and Network Write Instructions

Figure 6-6 shows the receive buffer (VB200) and transmit buffer (VB300) for accessing the data in station 2. The S7-200 uses a Network Read instruction to read the control and status information on a continuous basis from each of the case packers. Each time a case packer has packed 100 cases, the diverter notes this and sends a message to clear the status word using a Network Write instruction.

Receive Buffer for reading from Case Packer #1					Transmit Buffer for clearing the count of Case Packer #1						
	7				0		7				0
VB200	D	A	E	0	Error Code	VB300	D	A	E	0	Error Code
VB201	Remote station address = 2					VB301	Remote station address = 2				
VB202	Pointer to the					VB302	Pointer to the				
VB203	data area					VB303	data area				
VB204	in the					VB304	in the				
VB205	Remote station = (&VB100)					VB305	Remote station = (&VB101)				
VB206	Data length = 3 bytes					VB306	Data length = 2 bytes				
VB207	Control					VB307	0				
VB208	Status (MSB)					VB308	0				
VB209	Status (LSB)										

Figure 6-6 Sample TBL Data for the Network Read/Write Example

Example: Network Read and Network Write Instructions

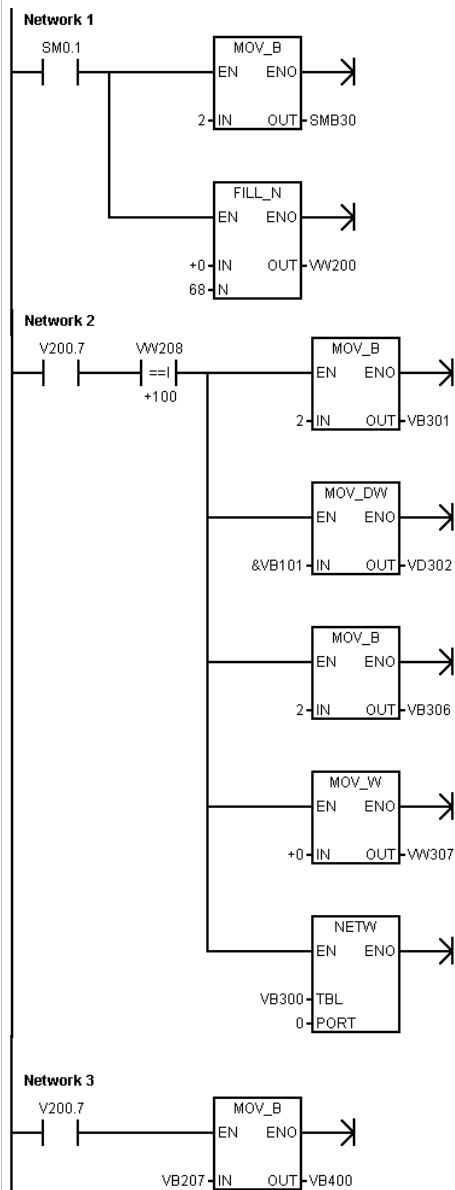

Network 1 //On the first scan, enable the PPI master mode
//and clear all receive and transmit buffers.

```
LD SM0.1
MOVB 2, SMB30
FILL +0, VW200, 68
```

Network 2 //When the NETR Done bit (V200.7) is set
//and 100 cases have been packed:
//1. Load the station address of case packer #1.
//2. Load a pointer to the data in the remote station.
//3. Load the length of data to be transmitted.
//4. Load the data to transmit.
//5. Reset the number of cases packed
// by case packer #1

```
LD V200.7
AW= VW208, +100
MOVB 2, VB301
MOVD &VB101, VD302
MOVB 2, VB306
MOVW +0, VW307
NETW VB300, 0
```

Network 3 //When the NETR Done bit is set, save the control
//data from case packer #1.

```
LD V200.7
MOVB VB207, VB400
```

Example: Network Read and Network Write Instructions , continued

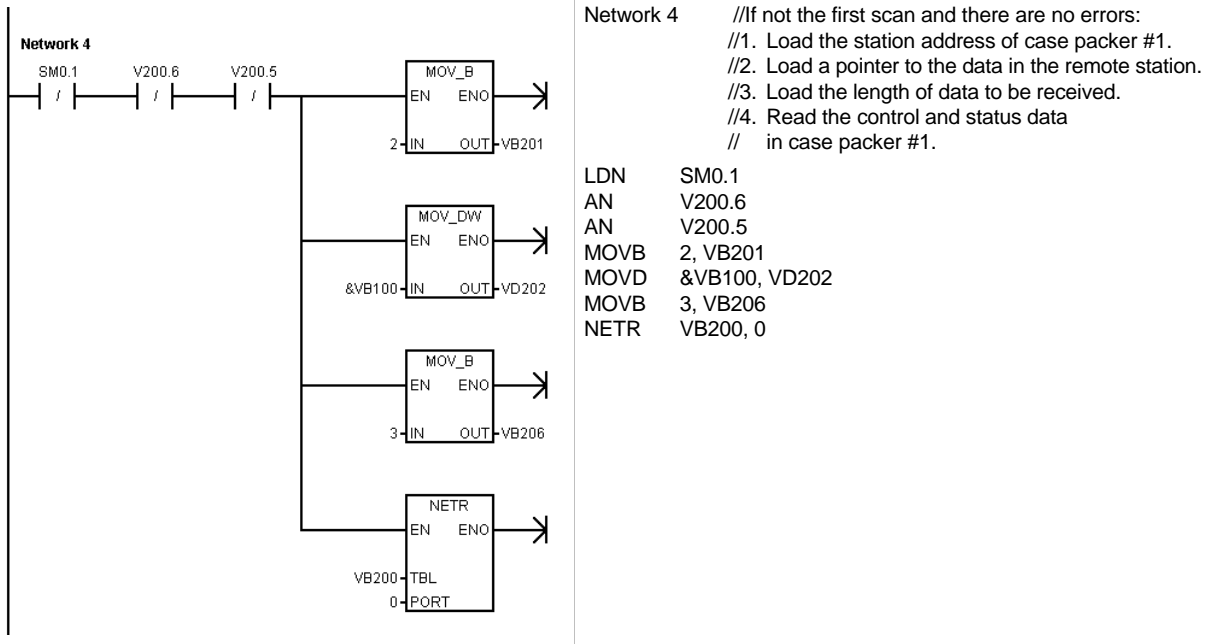

6

Transmit and Receive Instructions (Freeport)

The Transmit instruction (XMT) is used in Freeport mode to transmit data by means of the communications port(s).

The Receive instruction (RCV) initiates or terminates the receive message function. You must specify a start and an end condition for the Receive box to operate. Messages received through the specified port (PORT) are stored in the data buffer (TBL). The first entry in the data buffer specifies the number of bytes received.

Error conditions that set ENO = 0

- 0006 (indirect address)
- 0009 (simultaneous Transmit/Receive on port 0)
- 000B (simultaneous Transmit/Receive on port 1)
- Receive parameter error sets SM86.6 or SM186.6
- S7-200 CPU is not in Freeport mode

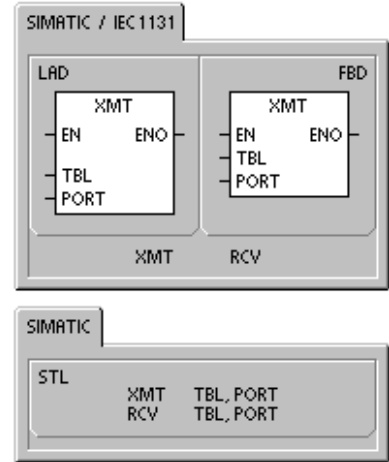

Table 6-11 Valid Operands for the Transmit and Receive Instructions

Inputs/Outputs	Data Type	Operands
TBL	BYTE	IB, QB, VB, MB, SMB, SB, *VD, *LD, *AC
PORT	BYTE	Constant <i>for CPU 221, CPU 222, CPU 224:</i> 0 <i>for CPU 226 and CPU 226XM:</i> 0 or 1

For more information about using Freeport mode, see the section Creating User-Defined Protocols with Freeport Mode on page 222 in Chapter 7.

Using Freeport Mode to Control the Serial Communications Port

You can select the Freeport mode to control the serial communications port of the S7-200 by means of the user program. When you select Freeport mode, your program controls the operation of the communications port through the use of the receive interrupts, the transmit interrupts, the Transmit instruction, and the Receive instruction. The communications protocol is entirely controlled by the ladder program while in Freeport mode. SMB30 (for port 0) and SMB130 (for port 1 if your S7-200 has two ports) are used to select the baud rate and parity.

The Freeport mode is disabled and normal communications are re-established (for example, programming device access) when the S7-200 is in STOP mode.

In the simplest case, you can send a message to a printer or a display using only the Transmit (XMT) instruction. Other examples include a connection to a bar code reader, a weighing scale, and a welder. In each case, you must write your program to support the protocol that is used by the device with which the S7-200 communicates while in Freeport mode.

Freeport communications are possible only when the S7-200 is in RUN mode. Enable the Freeport mode by setting a value of 01 in the protocol select field of SMB30 (Port 0) or SMB130 (Port 1). While in Freeport mode, communications with the programming device are not possible.



Tip

Freeport mode can be controlled using special memory bit SM0.7, which reflects the current position of the operating mode switch. When SM0.7 is equal to 0, the switch is in TERM position; when SM0.7 = 1, the operating mode switch is in RUN position. If you enable Freeport mode only when the switch is in RUN position, you can use the programming device to monitor or control the S7-200 operation by changing the switch to any other position.

Changing PPI Communications to Freeport Mode

SMB30 and SMB130 configure the communications ports, 0 and 1 respectively, for Freeport operation and provide selection of baud rate, parity, and number of data bits. Figure 6-7 describes the Freeport control byte. One stop bit is generated for all configurations.

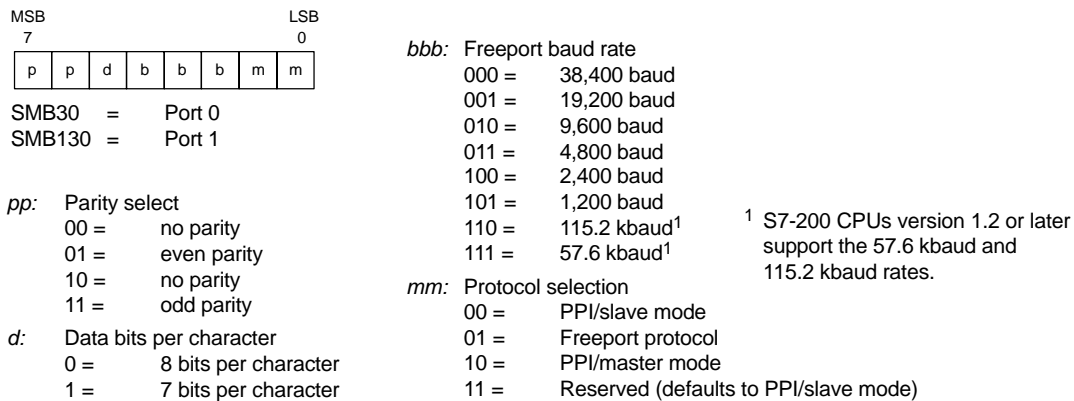

Figure 6-7 SM Control Byte for Freeport Mode (SMB30 or SMB130)

Transmitting Data

The Transmit instruction lets you send a buffer of one or more characters, up to a maximum of 255.

Figure 6-8 shows the format of the Transmit buffer.

If an interrupt routine is attached to the transmit complete event, the S7-200 generates an interrupt (interrupt event 9 for port 0 and interrupt event 26 for port 1) after the last character of the buffer is sent.

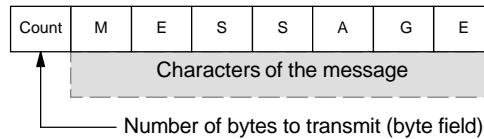

Figure 6-8 Format for the Transmit Buffer

You can make transmissions without using interrupts (for example, sending a message to a printer) by monitoring SM4.5 or SM4.6 to signal when transmission is complete.

You can use the Transmit instruction to generate a BREAK condition by setting the number of characters to zero and then executing the Transmit instruction. This generates a BREAK condition on the line for 16-bit times at the current baud rate. Transmitting a BREAK is handled in the same manner as transmitting any other message, in that a Transmit interrupt is generated when the BREAK is complete and SM4.5 or SM4.6 signals the current status of the Transmit operation.

Receiving Data

The Receive instruction lets you receive a buffer of one or more characters, up to a maximum of 255.

Figure 6-9 shows the format of the Receive buffer.

If an interrupt routine is attached to the receive message complete event, the S7-200 generates an interrupt (interrupt event 23 for port 0 and interrupt event 24 for port 1) after the last character of the buffer is received.

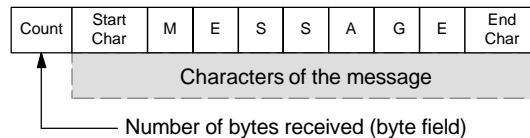

Figure 6-9 Format for the Receive Buffer

You can receive messages without using interrupts by monitoring SMB86 (port 0) or SMB186 (port 1). This byte is non-zero when the Receive instruction is inactive or has been terminated. It is zero when a receive is in progress.

As shown in Table 6-12, the Receive instruction allows you to select the message start and message end conditions, using SMB86 through SMB94 for port 0 and SMB186 through SMB194 for port 1.



Tip

The receive message function is automatically terminated in case of an overrun or a parity error. You must define a start condition and an end condition (maximum character count) for the receive message function to operate.

Table 6-12 Bytes of the Receive Buffer (SMB86 to SMB94, and SM1B86 to SMB194)

Port 0	Port 1	Description												
SMB86	SMB186	Receive message status byte <table style="margin-left: 20px; border-collapse: collapse;"> <tr> <td style="text-align: right; padding-right: 5px;">MSB</td> <td style="text-align: center;">7</td> <td style="padding: 0 5px;">n</td> <td style="padding: 0 5px;">r</td> <td style="padding: 0 5px;">e</td> <td style="padding: 0 5px;">0</td> <td style="padding: 0 5px;">0</td> <td style="padding: 0 5px;">t</td> <td style="padding: 0 5px;">c</td> <td style="padding: 0 5px;">p</td> <td style="text-align: left; padding-left: 5px;">LSB</td> <td style="text-align: center;">0</td> </tr> </table> n: 1 = Receive message function terminated: user issued disable command. r: 1 = Receive message function terminated: error in input parameters or missing start or end condition. e: 1 = End character received. t: 1 = Receive message function terminated: timer expired. c: 1 = Receive message function terminated: maximum character count achieved. p: 1 = Receive message function terminated: a parity error.	MSB	7	n	r	e	0	0	t	c	p	LSB	0
MSB	7	n	r	e	0	0	t	c	p	LSB	0			
SMB87	SMB187	Receive message control byte <table style="margin-left: 20px; border-collapse: collapse;"> <tr> <td style="text-align: right; padding-right: 5px;">MSB</td> <td style="text-align: center;">7</td> <td style="padding: 0 5px;">en</td> <td style="padding: 0 5px;">sc</td> <td style="padding: 0 5px;">ec</td> <td style="padding: 0 5px;">il</td> <td style="padding: 0 5px;">c/m</td> <td style="padding: 0 5px;">tmr</td> <td style="padding: 0 5px;">bk</td> <td style="padding: 0 5px;">0</td> <td style="text-align: left; padding-left: 5px;">LSB</td> <td style="text-align: center;">0</td> </tr> </table> en: 0 =Receive message function is disabled. 1 =Receive message function is enabled. The enable/disable receive message bit is checked each time the RCV instruction is executed. sc: 0 =Ignore SMB88 or SMB188. 1 =Use the value of SMB88 or SMB188 to detect start of message. ec: 0 =Ignore SMB89 or SMB189. 1 =Use the value of SMB89 or SMB189 to detect end of message. il: 0 =Ignore SMW90 or SMW190. 1 =Use the value of SMW90 or SMW190 to detect an idle line condition. c/m: 0 =Timer is an inter-character timer. 1 =Timer is a message timer. tmr: 0 =Ignore SMW92 or SMW192. 1 =Terminate receive if the time period in SMW92 or SMW192 is exceeded. bk: 0 =Ignore break conditions. 1 =Use break condition as start of message detection.	MSB	7	en	sc	ec	il	c/m	tmr	bk	0	LSB	0
MSB	7	en	sc	ec	il	c/m	tmr	bk	0	LSB	0			
SMB88	SMB188	Start of message character.												
SMB89	SMB189	End of message character.												
SMW90	SMW190	Idle line time period given in milliseconds. The first character received after idle line time has expired is the start of a new message.												
SMW92	SMW192	Inter-character/message timer time-out value given in milliseconds. If the time period is exceeded, the receive message function is terminated.												
SMB94	SMB194	Maximum number of characters to be received (1 to 255 bytes). This range must be set to the expected maximum buffer size, even if the character count message termination is not used.												

Start and End Conditions for the Receive Instruction

The Receive instruction uses the bits of the receive message control byte (SMB87 or SMB187) to define the message start and end conditions.



Tip

If there is traffic present on the communications port from other devices when the Receive instruction is executed, the receive message function could begin receiving a character in the middle of that character, resulting in a possible parity error and termination of the receive message function. If parity is not enabled the received message could contain incorrect characters. This situation can occur when the start condition is specified to be a specific start character or any character, as described in item 2. and item 6. below.

The Receive instruction supports several message start conditions. Specifying a start condition involving a break or an idle line detection avoids this problem by forcing the receive message function to synchronize the start of the message with the start of a character before placing characters into the message buffer.

The Receive instruction supports several start conditions:

1. **Idle line detection:** The idle line condition is defined as a quiet or idle time on the transmission line. A receive is started when the communications line has been quiet or idle for the number of milliseconds specified in SMW90 or SMW190. When the Receive instruction in your program is executed, the receive message function initiates a search for an idle line condition. If any characters are received before the idle line time expires, the receive message function ignores those characters and restarts the idle line timer with the time from SMW90 or SMW190. See Figure 6-10. After the idle line time expires, the receive message function stores all subsequent characters received in the message buffer.

The idle line time should always be greater than the time to transmit one character (start bit, data bits, parity and stop bits) at the specified baud rate. A typical value for the idle line time is three character times at the specified baud rate.

You use idle line detection as a start condition for binary protocols, protocols where there is not a particular start character, or when the protocol specifies a minimum time between messages.

Setup: $il = 1, sc = 0, bk = 0, SMW90/SMW190 = \text{idle line timeout in milliseconds}$

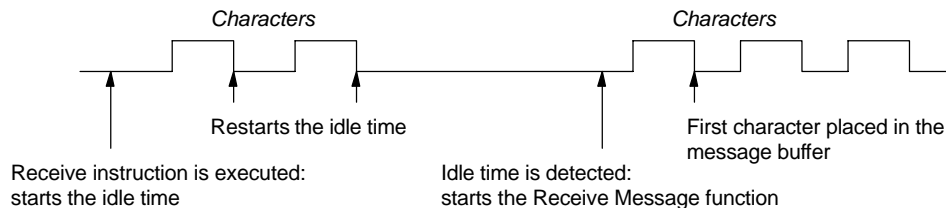

Figure 6-10 Using Idle Time Detection to Start the Receive Instruction

2. **Start character detection:** The start character is any character which is used as the first character of a message. A message is started when the start character specified in SMB88 or SMB188 is received. The receive message function stores the start character in the receive buffer as the first character of the message. The receive message function ignores any characters that are received before the start character. The start character and all characters received after the start character are stored in the message buffer.

Typically, you use start character detection for ASCII protocols in which all messages start with the same character.

Setup: $il = 0, sc = 1, bk = 0, SMW90/SMW190 = \text{don't care}, SMB88/SMB188 = \text{start character}$

3. *Idle line and start character:* The Receive instruction can start a message with the combination of an idle line and a start character. When the Receive instruction is executed, the receive message function searches for an idle line condition. After finding the idle line condition, the receive message function looks for the specified start character. If any character but the start character is received, the receive message function restarts the search for an idle line condition. All characters received before the idle line condition has been satisfied and before the start character has been received are ignored. The start character is placed in the message buffer along with all subsequent characters.

The idle line time should always be greater than the time to transmit one character (start bit, data bits, parity and stop bits) at the specified baud rate. A typical value for the idle line time is three character times at the specified baud rate.

Typically, you use this type of start condition when there is a protocol that specifies a minimum time between messages, and the first character of the message is an address or something which specifies a particular device. This is most useful when implementing a protocol where there are multiple devices on the communications link. In this case the Receive instruction triggers an interrupt only when a message is received for the specific address or devices specified by the start character.

Setup: $il = 1, sc = 1, bk = 0, SMW90/SMW190 > 0, SMB88/SMB188 = \text{start character}$

4. *Break detection:* A break is indicated when the received data is held to a zero value for a time greater than a full character transmission time. A full character transmission time is defined as the total time of the start, data, parity and stop bits. If the Receive instruction is configured to start a message on receiving a break condition, any characters received after the break condition are placed in the message buffer. Any characters received before the break condition are ignored.

Typically, you use break detection as a start condition only when a protocol requires it.

Setup: $il = 0, sc = 0, bk = 1, SMW90/SMW190 = \text{don't care}, SMB88/SMB188 = \text{don't care}$

5. *Break and a start character:* The Receive instruction can be configured to start receiving characters after receiving a break condition, and then a specific start character, in that sequence. After the break condition, the receive message function looks for the specified start character. If any character but the start character is received, the receive message function restarts the search for an break condition. All characters received before the break condition has been satisfied and before the start character has been received are ignored. The start character is placed in the message buffer along with all subsequent characters.

Setup: $il = 0, sc = 1, bk = 1, SMW90/SMW190 = \text{don't care}, SMB88/SMB188 = \text{start character}$

6. *Any character:* The Receive instruction can be configured to immediately start receiving any and all characters and placing them in the message buffer. This is a special case of the idle line detection. In this case the idle line time (SMW90 or SMW190) is set to zero. This forces the Receive instruction to begin receiving characters immediately upon execution.

Setup: $il = 1, sc = 0, bk = 0, SMW90/SMW190 = 0, SMB88/SMB188 = \text{don't care}$

Starting a message on any character allows the message timer to be used to time out the receiving of a message. This is useful in cases where Freeport is used to implement the master or host portion of a protocol and there is a need to time out if no response is received from a slave device within a specified amount of time. The message timer starts when the Receive instruction executes because the idle line time was set to zero. The message timer times out and terminates the receive message function if no other end condition is satisfied.

Setup: $il = 1, sc = 0, bk = 0, SMW90/SMW190 = 0, SMB88/SMB188 = \text{don't care}, c/m = 1, tmr = 1, SMW92 = \text{message timeout in milliseconds}$

The Receive instruction supports several ways to terminate a message. The message can be terminated on one or a combination of the following:

1. *End character detection:* The end character is any character which is used to denote the end of the message. After finding the start condition, the Receive instruction checks each character received to see if it matches the end character. When the end character is received, it is placed in the message buffer and the receive is terminated.

Typically, you use end character detection with ASCII protocols where every message ends with a specific character. You can use end character detection in combination with the intercharacter timer, the message timer or the maximum character count to terminate a message.

Setup: $ec = 1$, SMB89/SMB189 = end character

2. *Intercharacter timer:* The intercharacter time is the time measured from the end of one character (the stop bit) to the end of the next character (the stop bit). If the time between characters (including the second character) exceeds the number of milliseconds specified in SMW92 or SMW192, the receive message function is terminated. The intercharacter timer is restarted on each character received. See Figure 6-11.

You can use the intercharacter timer to terminate a message for protocols which do not have a specific end-of-message character. This timer must be set to a value greater than one character time at the selected baud rate since this timer always includes the time to receive one entire character (start bit, data bits, parity and stop bits).

You can use the intercharacter timer in combination with the end character detection and the maximum character count to terminate a message.

Setup: $c/m = 0$, $tmr = 1$, SMW92/SMW192 = timeout in milliseconds

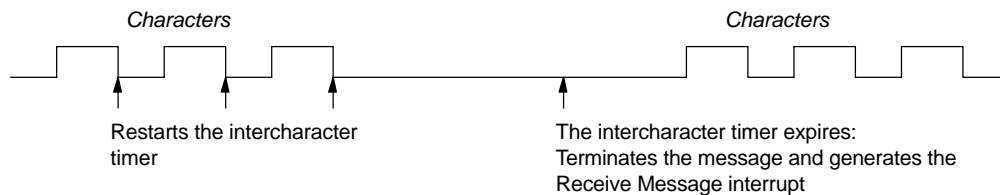

Figure 6-11 Using the Intercharacter Timer to Terminate the Receive Instruction

3. *Message timer:* The message timer terminates a message at a specified time after the start of the message. The message timer starts as soon as the start condition(s) for the receive message function have been met. The message timer expires when the number of milliseconds specified in SMW92 or SMW192 have passed. See Figure 6-12.

Typically, you use a message timer when the communications devices cannot guarantee that there will not be time gaps between characters or when operating over modems. For modems, you can use a message timer to specify a maximum time allowed to receive the message after the message has started. A typical value for a message timer would be about 1.5 times the time required to receive the longest possible message at the selected baud rate.

You can use the message timer in combination with the end character detection and the maximum character count to terminate a message.

Setup: $c/m = 1$, $tmr = 1$, SMW92/SMW192 = timeout in milliseconds

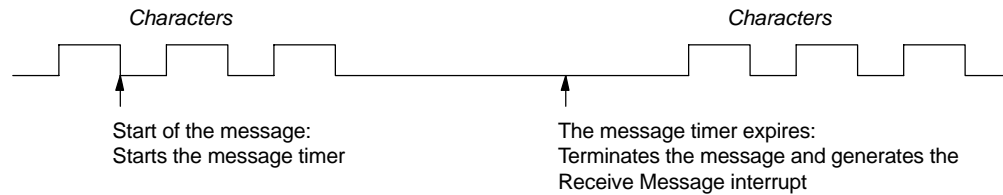

Figure 6-12 Using the Message Timer to Terminate the Receive Instruction

4. *Maximum character count:* The Receive instruction must be told the maximum number of characters to receive (SMB94 or SMB194). When this value is met or exceeded, the receive message function is terminated. The Receive instruction requires that the user specify a maximum character count even if this is not specifically used as a terminating condition. This is because the Receive instruction needs to know the maximum size of the receive message so that user data placed after the message buffer is not overwritten.

The maximum character count can be used to terminate messages for protocols where the message length is known and always the same. The maximum character count is always used in combination with the end character detection, intercharacter timer, or message timer.

5. *Parity errors:* The Receive instruction is automatically terminated when the hardware signals a parity error on a received character. Parity errors are only possible if parity is enabled in SMB30 or SMB130. There is no way to disable this function.
6. *User termination:* The user program can terminate a receive message function by executing another Receive instruction with the enable bit (EN) in SMB87 or SMB187 set to zero. This immediately terminates the receive message function.

Using Character Interrupt Control to Receive Data

To allow complete flexibility in protocol support, you can also receive data using character interrupt control. Each character received generates an interrupt. The received character is placed in SMB2, and the parity status (if enabled) is placed in SM3.0 just prior to execution of the interrupt routine attached to the receive character event. SMB2 is the Freeport receive character buffer. Each character received while in Freeport mode is placed in this location for easy access from the user program. SMB3 is used for Freeport mode and contains a parity error bit that is turned on when a parity error is detected on a received character. All other bits of the byte are reserved. Use the parity bit either to discard the message or to generate a negative acknowledgement to the message.

When the character interrupt is used at high baud rates (38.4 kbaud to 115.2 kbaud), the time between interrupts is very short. For example, the character interrupt for 38.4 kbaud is 260 microseconds, for 57.6 kbaud is 173 microseconds, and for 115.2 kbaud is 86 microseconds. Ensure that you keep the interrupt routines very short to avoid missing characters, or else use the Receive instruction.



Tip

SMB2 and SMB3 are shared between Port 0 and Port 1. When the reception of a character on Port 0 results in the execution of the interrupt routine attached to that event (interrupt event 8), SMB2 contains the character received on Port 0, and SMB3 contains the parity status of that character. When the reception of a character on Port 1 results in the execution of the interrupt routine attached to that event (interrupt event 25), SMB2 contains the character received on Port 1 and SMB3 contains the parity status of that character.

Example: Transmit and Receive Instructions

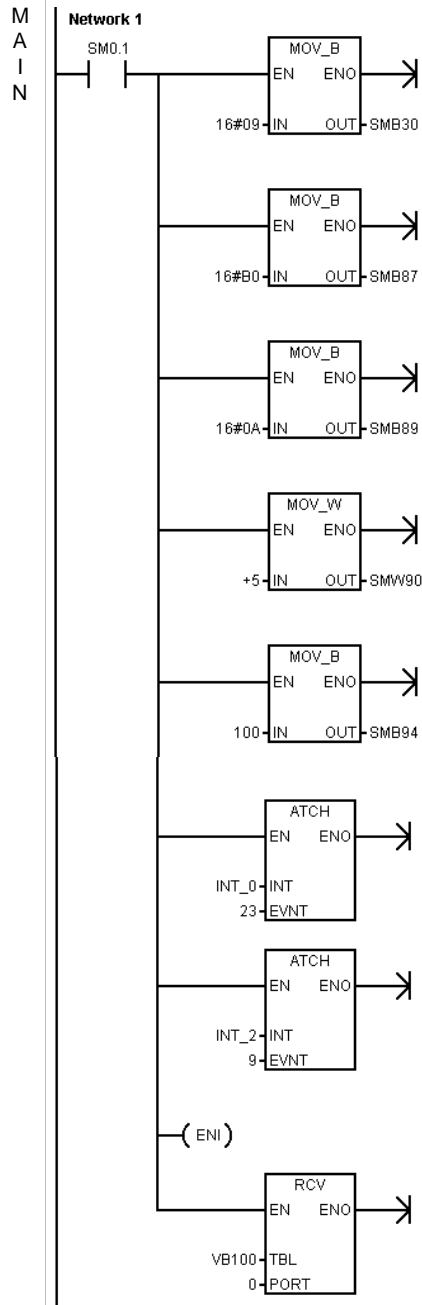

```

Network 1 //This program receives a string of characters until
//a line feed character is received.
//The message is then transmitted back to the sender.
LD SM0.1 //On the first scan:
MOV B 16#09, SMB30 //1. Initialize Freeport:
// - Select 9600 baud.
// - Select 8 data bits.
// - Select no parity.
MOV B 16#B0, SMB87 //2. Initialize RCV message control byte:
// - RCV enabled.
// - Detect end of message character.
// - Detect idle line condition as the message
// start condition.
MOV B 16#0A, SMB89 //3. Set end of message character
// to hex 0A (line feed).
MOV W +5, SMW90 //4. Set idle line timeout
// to 5 ms.
MOV B 100, SMB94 //5. Set maximum number of characters
// to 100.
ATCH INT_0, 23 //6. Attach interrupt 0
// to the Receive Complete event.
ATCH INT_2, 9 //7. Attach interrupt 2
// to the Transmit Complete event.
ENI //8. Enable user interrupts.
RCV VB100, 0 //9. Enable receive box with buffer at VB100.
    
```

6

Example: Transmit and Receive Instructions, continued

<p style="text-align: center;">I N T 0</p>	<p>Network 1</p>	<p>Network 1 //Receive complete interrupt routine: //1. If receive status shows receive of end character, // then attach a 10 ms timer to trigger a transmit and return. //2. If the receive completed for any other reason, // then start a new receive.</p> <pre> LDB= SMB86, 16#20 MOVB 10, SMB34 ATCH INT_1, 10 CRETI NOT RCV VB100, 0 </pre>
<p style="text-align: center;">I N T 1</p>	<p>Network 1</p>	<p>Network 1 //10-ms Timer interrupt: //1. Detach timer interrupt. //2. Transmit message back to user on port.</p> <pre> LD SM0.0 DTCH 10 XMT VB100, 0 </pre>
<p style="text-align: center;">I N T 2</p>	<p>Network 1</p>	<p>Network 1 //Transmit Complete interrupt: //Enable another receive.</p> <pre> LD SM0.0 RCV VB100, 0 </pre>

Get Port Address and Set Port Address Instructions

The Get Port Address instruction (GPA) reads the station address of the S7-200 CPU port specified in PORT and places the value in the address specified in ADDR.

The Set Port Address instruction (SPA) sets the port station address (PORT) to the value specified in ADDR. The new address is not saved permanently. After a power cycle, the affected port returns to the last address (the one that was downloaded with the system block).

Error conditions that set ENO = 0:

- 0006 (indirect address)
- 0004 (attempted to perform a Set Port Address instruction in an interrupt routine)

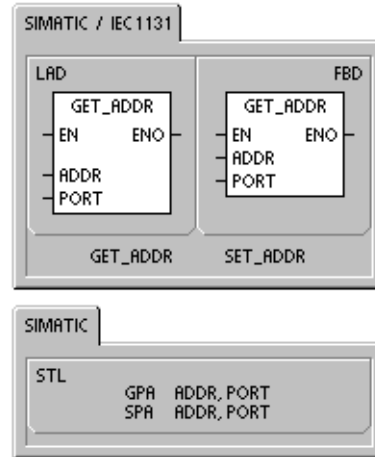

Table 6-13 Valid Operands for the Get Port Address and Set Port Address Instructions

Inputs/Outputs	Data Type	Operands
ADDR	BYTE	IB, QB, VB, MB, SMB, SB, LB, AC, *VD, *LD, *AC, Constant <i>(A constant value is valid only for the Set Port Address instruction.)</i>
PORT	BYTE	Constant for CPU 221, CPU 222, CPU 224: 0 for CPU 226 and CPU 226XM: 0 or 1

Compare Instructions

Comparing Numerical Values

The compare instructions are used to compare two values:

IN1 = IN2 IN1 >= IN2 IN1 <= IN2
 IN1 > IN2 IN1 < IN2 IN1 <> IN2

Compare Byte operations are unsigned.
 Compare Integer operations are signed.
 Compare Double Word operations are signed.
 Compare Real operations are signed.

For LAD and FBD: When the comparison is true, the Compare instruction turns on the contact (LAD) or output (FBD).

For STL: When the comparison is true, the Compare instruction Loads, ANDs, or ORs a 1 with the value on the top of the stack (STL).

When you use the IEC compare instructions, you can use various data types for the inputs. However, both input values must be of the same data type.

Notice

The following conditions are fatal errors and cause your S7-200 to immediately stop the execution of your program:

- Illegal indirect address is encountered (any Compare instruction)
- Illegal real number (for example, NAN) is encountered (Compare Real instruction)

To prevent these conditions from occurring, ensure that you properly initialize pointers and values that contain real numbers before executing compare instructions that use these values.

Compare instructions are executed regardless of the state of power flow.

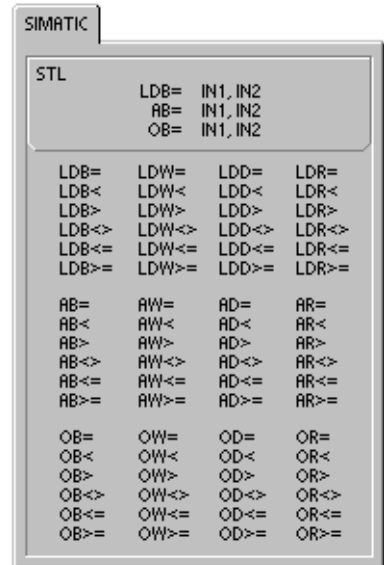
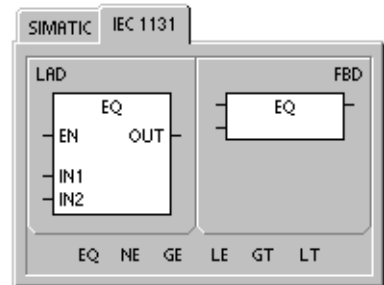
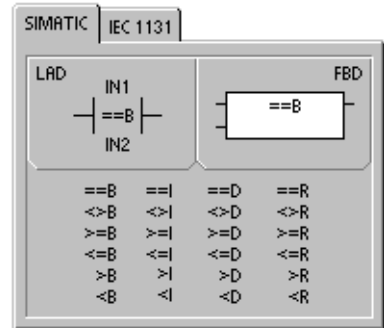
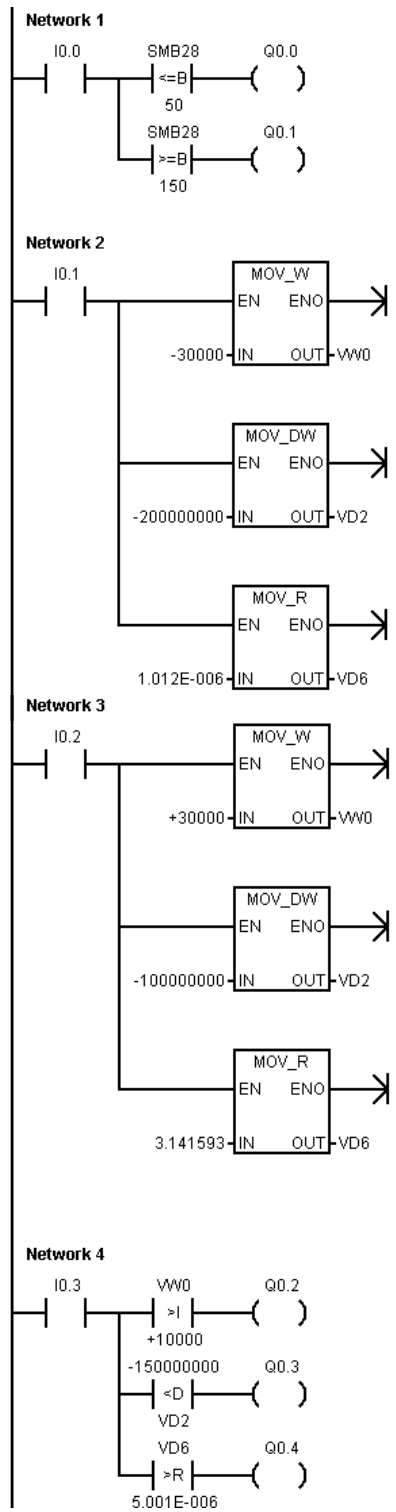

Table 6-14 Valid Operands for the Compare Instructions

Inputs/Outputs	Type	Operands
IN1, IN2	BYTE	IB, QB, VB, MB, SMB, SB, LB, AC, *VD, *LD, *AC, Constant
	INT	IW, QW, VW, MW, SMW, SW, T, C, LW, AC, AIW, *VD, *LD, *AC, Constant
	DINT	ID, QD, VD, MD, SMD, SD, LD, AC, HC, *VD, *LD, *AC, Constant
	REAL	ID, QD, VD, MD, SMD, SD, LD, AC, *VD, *LD, *AC, Constant
Output (or OUT)	BOOL	I, Q, V, M, SM, S, T, C, L, Power Flow

Example: Compare Instructions



```

Network 1 //Turn analog adjustment potentiometer 0 to vary
//the SMB28 byte value.
//Q0.0 is active when the SMB28 value is less than
//or equal to 50.
//Q0.1 is active when the SMB28 value is greater than
//or equal to 150.
//The status indicator is on when the comparison is true.

LD I0.0
LPS
AB<= SMB28, 50
= Q0.0
LPP
AB>= SMB28, 150
= Q0.1

Network 2 //Load V memory addresses with low values
//that make the comparisons false and that turn
//the status indicators off.

LD I0.1
MOVW -30000, VV0
MOVD -200000000, VD2
MOVR 1.012E-006, VD6

Network 3 //Load V memory addresses with high values
//that make the comparisons true and that turn
//the status indicators on.

LD I0.2
MOVW +30000, VV0
MOVD -100000000, VD2
MOVR 3.141593, VD6

Network 4 //The Integer Word comparison tests to find if
//VV0 > +10000 is true.
//Uses program constants to show the different
//data types. You can also compare two values
//stored in programmable memory like:
//VV0 > VV100

LD I0.3
LPS
AW> VV0, +10000
= Q0.2
LRD
AD< -150000000, VD2
= Q0.3
LPP
AR> VD6, 5.001E-006
= Q0.4
    
```

Compare String

The Compare String instruction compares two strings of ASCII characters:

IN1 = IN2 IN1 <> IN2

When the comparison is true, the Compare instruction turns the contact (LAD) or output (FBD) on, or the compare instruction Loads, ANDs or ORs a 1 with the value on the top of the stack (STL).

Notice

The following conditions are fatal errors and cause your S7-200 to immediately stop the execution of your program:

- Illegal indirect address is encountered (any compare instruction)
- A string with a length greater than 254 characters is encountered (Compare String instruction)
- A string whose starting address and length are such that it will not fit in the specified memory area (Compare String instruction)

To prevent these conditions from occurring, ensure that you properly initialize pointers and memory locations that are intended to hold ASCII strings prior to executing compare instructions that use these values. Ensure that the buffer reserved for an ASCII string can reside completely within the specified memory area.

Compare instructions are executed regardless of the state of power flow.

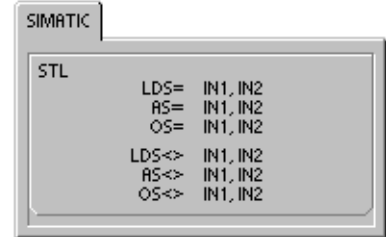
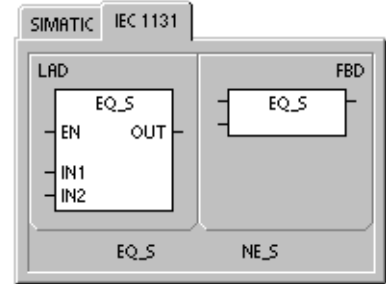
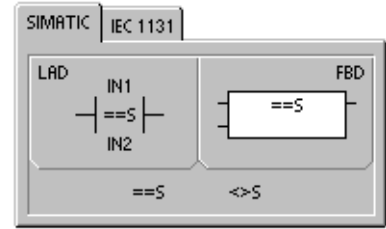

6

Table 6-15 Valid Operands for the Compare String Instructions

Inputs/Outputs	Type	Operands
IN1, IN2	BYTE (String)	VB, LB, *VD, *LD, *AC
Output (OUT)	BOOL	I, Q, V, M, SM, S, T, C, L, Power Flow

Conversion Instructions

Standard Conversion Instructions

Numerical Conversions

The Byte to Integer (BTI), Integer to Byte (ITB), Integer to Double Integer (ITD), Double Integer to Integer (DTI), Double Integer to Real (DTR), BCD to Integer (BCDI) and Integer to BCD (IBCD) instructions convert an input value IN to the specified format and stores the output value in the memory location specified by OUT. For example, you can convert a double integer value to a real number. You can also convert between integer and BCD formats.

Round and Truncate

The Round instruction (ROUND) converts a real value IN to a double integer value and places the rounded result into the variable specified by OUT.

The Truncate instruction (TRUNC) converts a real number IN into a double integer and places the whole-number portion of the result into the variable specified by OUT.

Segment

The Segment instruction (SEG) allows you to generate a bit pattern that illuminates the segments of a seven-segment display.

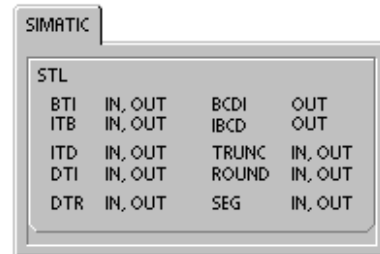
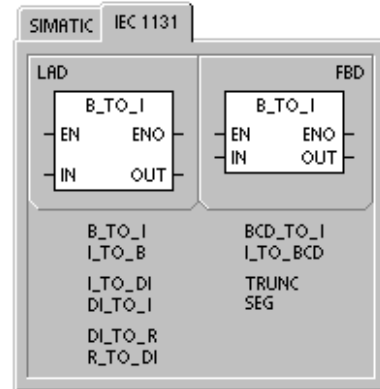
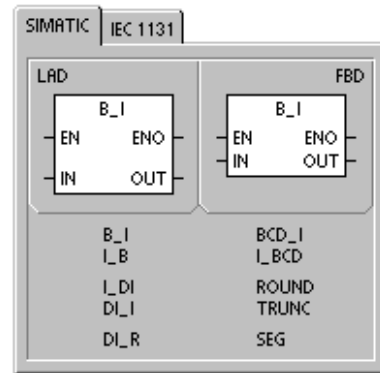

Table 6-16 Valid Operands for the Standard Conversion Instructions

Inputs/Outputs	Data Type	Operands
IN	BYTE WORD, INT DINT REAL	IB, QB, VB, MB, SMB, SB, LB, AC, *VD, *LD, *AC, Constant IW, QW, VW, MW, SMW, SW, T, C, LW, AIW, AC, *VD, *LD, *AC, Constant ID, QD, VD, MD, SMD, SD, LD, HC, AC, *VD, *LD, *AC, Constant ID, QD, VD, MD, SMD, SD, LD, AC, *VD, *LD, *AC, Constant
OUT	BYTE WORD, INT DINT, REAL	IB, QB, VB, MB, SMB, SB, LB, AC, *VD, *LD, *AC IW, QW, VW, MW, SMW, SW, T, C, LW, AC, *VD, *LD, *AC ID, QD, VD, MD, SMD, SD, LD, AC, *VD, *LD, *AC

Operation of the BCD to Integer and Integer to BCD Instructions

The BCD to Integer instruction (BCDI) converts the binary-coded decimal value IN to an integer value and loads the result into the variable specified by OUT. The valid range for IN is 0 to 9999 BCD.

The Integer to BCD instruction (IBCD) converts the input integer value IN to a binary-coded decimal and loads the result into the variable specified by OUT. The valid range for IN is 0 to 9999 integer.

Error conditions that set ENO = 0

- SM1.6 (invalid BCD)
- 0006 (indirect address)

SM bits affected:

- SM1.6 (invalid BCD)

Operation of the Double Integer to Real Instruction

The Double Integer to Real instruction (DTR) converts a 32-bit, signed integer IN into a 32-bit real number and places the result into the variable specified by OUT.

Error conditions that set ENO = 0

- 0006 (indirect address)

Operation of the Double Integer to Integer Instruction

The Double Integer to Integer instruction (DTI) converts the double integer value IN to an integer value and places the result into the variable specified by OUT.

If the value that you are converting is too large to be represented in the output, then the overflow bit is set and the output is not affected.

Error conditions that set ENO = 0

- SM1.1 (overflow)
- 0006 (indirect address)

SM bits affected:

- SM1.1 (overflow)

Operation of the Integer to Double Integer Instruction

The Integer to Double Integer instruction (ITD) converts the integer value IN to a double integer value and places the result into the variable specified by OUT. The sign is extended.

Error conditions that set ENO = 0

- 0006 (indirect address)

Operation of the Byte to Integer Instruction

The Byte to Integer instruction (BTI) converts the byte value IN to an integer value and places the result into the variable specified by OUT. The byte is unsigned, therefore there is no sign extension.

Error conditions that set ENO = 0

- 0006 (indirect address)

Operation of the Integer to Byte Instruction

The Integer to Byte instruction (ITB) converts the word value IN to a byte value and places the result into the variable specified by OUT. Values 0 to 255 are converted. All other values result in overflow and the output is not affected.

Error conditions that set ENO = 0

- SM1.1 (overflow)
- 0006 (indirect address)

SM bits affected:

- SM1.1 (overflow)



Tip

To change an integer to a real number, use the Integer to Double Integer instruction and then use the Double Integer to Real instruction.

Operation of the Round and Truncate Instructions

The Round instruction (ROUND) converts the real-number value IN to a double integer value and places the result into the variable specified by OUT. If the fraction portion is 0.5 or greater, the number is rounded up.

The Truncate instruction (TRUNC) converts a real-number value IN into a double integer and places the result into the variable specified by OUT. Only the whole number portion of the real number is converted, and the fraction is discarded.

If the value that you are converting is not a valid real number or is too large to be represented in the output, then the overflow bit is set and the output is not affected.

Error conditions that set ENO = 0

- SM1.1 (overflow)
- 0006 (indirect address)

SM bits affected:

- SM1.1 (overflow)

6

Example: Standard Conversion Instructions

```

Network 1 //Convert inches to centimeters:
//1. Load a counter value (inches) into AC1.
//2. Convert the value to a real number.
//3. Multiply by 2.54 (convert to centimeters).
//4. Convert the value back to an integer.
LD I0.0
ITD C10, AC1
DTR AC1, VD0
MOVR VD0, VD8
*R VD4, VD8
ROUND VD8, VD12

Network 2 //Convert a BCD value to an integer
LD I0.3
BCDI AC0
    
```

Double Word Integer to Real and Round			BCD to Integer	
C10	101	Count = 101 inches	AC0	1234
VD0	101.0	Count (as a real number)		BCDI
VD4	2.54	2.54 constant (inches to centimeters)	AC0	04D2
VD8	256.54	256.54 centimeters as real number		
VD12	257	257 centimeters as double integer		

Operation of the Segment Instruction

To illuminate the segments of a seven-segment display, the Segment instruction (SEG) converts the character (byte) specified by IN to generate a bit pattern (byte) at the location specified by OUT.

The illuminated segments represent the character in the least significant digit of the input byte. Figure 6-13 shows the seven-segment display coding used by the Segment instruction.

Error conditions that set ENO = 0

- 0006 (indirect address)

(IN) LSD	Segment Display	(OUT) -gfe dcba
0		0011 1111
1		0000 0110
2		0101 1011
3		0100 1111
4		0110 0110
5		0110 1101
6		0111 1101
7		0000 0111

(IN) LSD	Segment Display	(OUT) -gfe dcba
8		0111 1111
9		0110 0111
A		0111 0111
B		0111 1100
C		0011 1001
D		0101 1110
E		0111 1001
F		0111 0001

Figure 6-13 Coding for a Seven-Segment Display

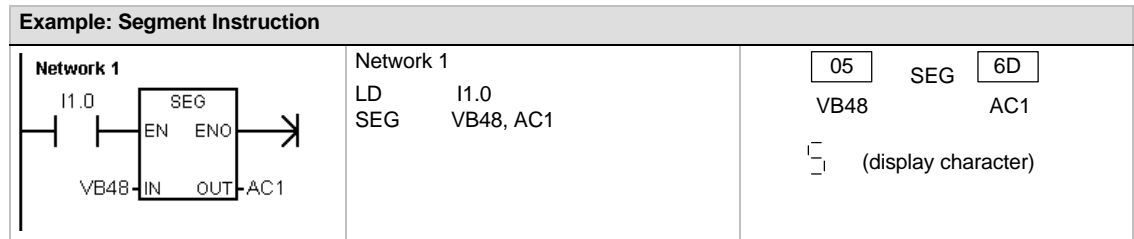

ASCII Conversion Instructions

Valid ASCII characters are the hexadecimal values 30 to 39, and 41 to 46.

Converting between ASCII and Hexadecimal Values

The ASCII to Hexadecimal instruction (ATH) converts a number LEN of ASCII characters, starting at IN, to hexadecimal digits starting at OUT. The Hexadecimal to ASCII instruction (HTA) converts the hexadecimal digits, starting with the input byte IN, to ASCII characters starting at OUT. The number of hexadecimal digits to be converted is specified by length LEN.

The maximum number of ASCII characters or hexadecimal digits that can be converted is 255.

Error conditions that set ENO = 0

- SM1.7 (illegal ASCII) *ASCII to Hexadecimal only*
- 0006 (indirect address)
- 0091 (operand out of range)

SM bits affected:

- SM1.7 (illegal ASCII)

Converting Numerical Values to ASCII

The Integer to ASCII (ITA), Double Integer to ASCII (DTA), and Real to ASCII (RTA) instructions convert integer, double integer, or real number values to ASCII characters.

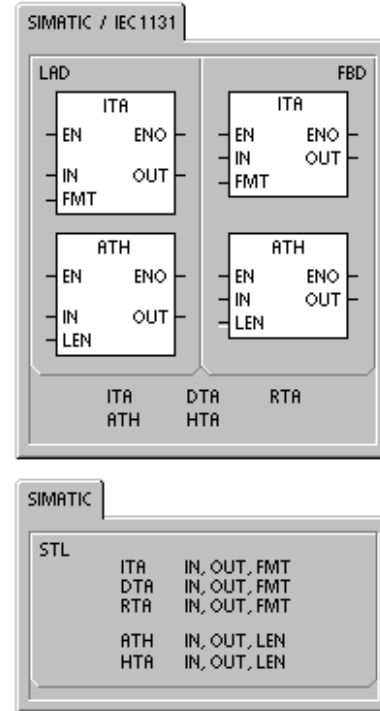

Table 6-17 Valid Operands for the ASCII Conversion Instructions

Inputs/Outputs	Data Type	Operands
IN	BYTE	IB, QB, VB, MB, SMB, SB, LB, *VD, *LD, *AC
	INT	IW, QW, VW, MW, SMW, SW, T, C, LW, AC, AIW, *VD, *LD, *AC, Constant
	DINT	ID, QD, VD, MD, SMD, SD, LD, AC, HC, *VD, *LD, *AC, Constant
	REAL	ID, QD, VD, MD, SMD, SD, LD, AC, *VD, *LD, *AC, Constant
LEN, FMT	BYTE	IB, QB, VB, MB, SMB, SB, LB, AC, *VD, *LD, *AC, Constant
OUT	BYTE	IB, QB, VB, MB, SMB, SB, LB, *VD, *LD, *AC

Operation of the Integer to ASCII Instruction

The Integer to ASCII instruction (ITA) converts an integer word IN to an array of ASCII characters. The format FMT specifies the conversion precision to the right of the decimal, and whether the decimal point is to be shown as a comma or a period. The resulting conversion is placed in 8 consecutive bytes beginning with OUT.

The array of ASCII characters is always 8 characters.

Figure 6-14 describes the format operand for the Integer to ASCII instruction. The size of the output buffer is always 8 bytes. The number of digits to the right of the decimal point in the output buffer is specified by the *nnn* field. The valid range of the *nnn* field is 0 to 5. Specifying 0 digits to the right of the decimal point causes the value to be displayed without a decimal point. For values of *nnn* bigger than 5, the output buffer is filled with ASCII spaces. The *c* bit specifies the use of either a comma (*c*=1) or a decimal point (*c*=0) as the separator between the whole number and the fraction. The upper 4 bits must be zero.

Error conditions that set ENO = 0

- 0006 (indirect address)
- Illegal format
- *nnn* > 5

Figure 6-14 shows examples of values that are formatted using a decimal point ($c=0$) with three digits to the right of the decimal point ($nnn=011$). The output buffer is formatted according to the following rules:

- Positive values are written to the output buffer without a sign.
- Negative values are written to the output buffer with a leading minus sign (-).
- Leading zeros to the left of the decimal point (except the digit adjacent to the decimal point) are suppressed.
- Values are right-justified in the output buffer.

FMT

MSB				LSB			
7	6	5	4	3	2	1	0
0	0	0	0	c	n	n	n

c = comma (1) or decimal point (0)
 nnn = digits to right of decimal point

	Out +1	Out +2	Out +3	Out +4	Out +5	Out +6	Out +7
in=12			0	.	0	1	2
in=-123		-	0	.	1	2	3
in=1234			1	.	2	3	4
in = -12345	-	1	2	.	3	4	5

Figure 6-14 FMT Operand for the Integer to ASCII (ITA) Instruction

6

Operation of the Double Integer to ASCII Instruction

The Double Integer to ASCII (DTA) instruction converts a double word IN to an array of ASCII characters. The format operand FMT specifies the conversion precision to the right of the decimal. The resulting conversion is placed in 12 consecutive bytes beginning with OUT.

Error conditions that set ENO = 0

- 0006 (indirect address)
- Illegal format
- $nnn > 5$

The size of the output buffer is always 12 bytes.

Figure 6-15 describes the format operand for the Double Integer to ASCII instruction. The number of digits to the right of the decimal point in the output buffer is specified by the nnn field. The valid range of the nnn field is 0 to 5. Specifying 0 digits to the right of the decimal point causes the value to be displayed without a decimal point. For values of nnn bigger than 5, the output buffer is filled with ASCII spaces. The c bit specifies the use of either a comma ($c=1$) or a decimal point ($c=0$) as the separator between the whole number and the fraction. The upper 4 bits must be zero.

Figure 6-15 shows examples of values that are formatted using a decimal point ($c=0$) with four digits to the right of the decimal point ($nnn=100$). The output buffer is formatted according to the following rules:

- Positive values are written to the output buffer without a sign.
- Negative values are written to the output buffer with a leading minus sign (-).
- Leading zeros to the left of the decimal point (except the digit adjacent to the decimal point) are suppressed.
- Values are right-justified in the output buffer.

FMT

MSB				LSB			
7	6	5	4	3	2	1	0
0	0	0	0	c	n	n	n

c = comma (1) or decimal point (0)
 nnn = digits to right of decimal point

	Out +1	Out +2	Out +3	Out +4	Out +5	Out +6	Out +7	Out +8	Out +9	Out +10	Out +11
in=-12					-	0	.	0	0	1	2
in=1234567				1	2	3	.	4	5	6	7

Figure 6-15 FMT Operand for the Double Integer to ASCII (DTA) Instruction

Operation of the Real to ASCII Instruction

The Real to ASCII instruction (RTA) converts a real-number value IN to ASCII characters. The format FMT specifies the conversion precision to the right of the decimal, whether the decimal point is shown as a comma or a period, and the output buffer size.

Error conditions that set ENO = 0

- 0006 (indirect address)
- nnn > 5
- ssss < 3
- ssss < number of characters in OUT

The resulting conversion is placed in an output buffer beginning with OUT.

The number (or length) of the resulting ASCII characters is the size of the output buffer and can be specified to a size ranging from 3 to 15 bytes or characters.

The real-number format used by the S7-200 supports a maximum of 7 significant digits. Attempting to display more than 7 significant digits produces a rounding error.

Figure 6-16 describes the format operand (FMT) for the RTA instruction. The size of the output buffer is specified by the ssss field. A size of 0, 1, or 2 bytes is not valid. The number of digits to the right of the decimal point in the output buffer is specified by the nnn field. The valid range of the nnn field is 0 to 5. Specifying 0 digits to the right of the decimal point causes the value to be displayed without a decimal point. The output buffer is filled with ASCII spaces for values of nnn bigger than 5 or when the specified output buffer is too small to store the converted value. The c bit specifies the use of either a comma (c=1) or a decimal point (c=0) as the separator between the whole number and the fraction.

Figure 6-16 also shows examples of values that are formatted using a decimal point (c=0) with one digit to the right of the decimal point (nnn=001) and a buffer size of six bytes (ssss=0110). The output buffer is formatted according to the following rules:

- Positive values are written to the output buffer without a sign.
- Negative values are written to the output buffer with a leading minus sign (-).
- Leading zeros to the left of the decimal point (except the digit adjacent to the decimal point) are suppressed.
- Values to the right of the decimal point are rounded to fit in the specified number of digits to the right of the decimal point.
- The size of the output buffer must be a minimum of three bytes more than the number of digits to the right of the decimal point.
- Values are right-justified in the output buffer.

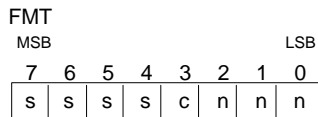

ssss = size of output buffer
 c = comma (1) or decimal point (0)
 nnn = digits to right of decimal point

	Out +1	Out +2	Out +3	Out +4	Out +5
in = 1234.5	1	2	3	4	5
in = -0.0004				0	.
in = -3.67526			-	3	.
in = 1.95				2	.

Figure 6-16 FMT Operand for the Real to ASCII (RTA) Instruction

Example: ASCII to Hexadecimal Instruction

<p>Network 1</p>	<p>Network 1</p> <pre>LD I3.2 ATH VB30, VB40, 3</pre>																											
<table style="width: 100%; border-collapse: collapse;"> <tr> <td style="text-align: center;">'3'</td> <td style="text-align: center;">'E'</td> <td style="text-align: center;">'A'</td> <td style="width: 20px;"></td> <td style="text-align: center;">ATH</td> <td style="text-align: center;">3E</td> <td style="text-align: center;">Ax</td> <td style="width: 20px;"></td> <td></td> </tr> <tr> <td style="text-align: center;">33</td> <td style="text-align: center;">45</td> <td style="text-align: center;">41</td> <td></td> <td></td> <td style="text-align: center;">3E</td> <td style="text-align: center;">Ax</td> <td></td> <td></td> </tr> <tr> <td style="text-align: center;">VB30</td> <td></td> <td></td> <td></td> <td></td> <td style="text-align: center;">VB40</td> <td></td> <td></td> <td></td> </tr> </table>	'3'	'E'	'A'		ATH	3E	Ax			33	45	41			3E	Ax			VB30					VB40				<p>Note: The X indicates that the “nibble” (half of a byte) is unchanged.</p>
'3'	'E'	'A'		ATH	3E	Ax																						
33	45	41			3E	Ax																						
VB30					VB40																							

Example: Integer to ASCII Instruction

<p>Network 1</p>	<p>Network 1</p> <pre>//Convert the integer value at VW2 //to 8 ASCII characters starting at VB10, //using a format of 16#0B //(a comma for the decimal point, //followed by 3 digits).</pre> <pre>LD I2.3 ITA VW2, VB10, 16#0B</pre>																						
<table style="width: 100%; border-collapse: collapse;"> <tr> <td style="text-align: center;">12345</td> <td style="width: 20px;"></td> <td style="text-align: center;">ITA</td> <td style="text-align: center;">20</td> <td style="text-align: center;">20</td> <td style="text-align: center;">31</td> <td style="text-align: center;">32</td> <td style="text-align: center;">2C</td> <td style="text-align: center;">33</td> <td style="text-align: center;">34</td> <td style="text-align: center;">35</td> </tr> <tr> <td style="text-align: center;">VW2</td> <td></td> <td></td> <td style="text-align: center;">VB10</td> <td style="text-align: center;">VB11</td> <td style="text-align: center;">...</td> <td></td> <td></td> <td></td> <td></td> <td></td> </tr> </table>	12345		ITA	20	20	31	32	2C	33	34	35	VW2			VB10	VB11	...						
12345		ITA	20	20	31	32	2C	33	34	35													
VW2			VB10	VB11	...																		

Example: Real to ASCII Instruction

<p>Network 1</p>	<p>Network 1</p> <pre>//Convert the real value at VD2 //to 10 ASCII characters starting at VB10, //using a format of 16#A3 //(a period for the decimal point, //followed by 3 digits).</pre> <pre>LD I2.3 RTA VD2, VB10, 16#A3</pre>																										
<table style="width: 100%; border-collapse: collapse;"> <tr> <td style="text-align: center;">123.45</td> <td style="width: 20px;"></td> <td style="text-align: center;">RTA</td> <td style="text-align: center;">20</td> <td style="text-align: center;">20</td> <td style="text-align: center;">20</td> <td style="text-align: center;">31</td> <td style="text-align: center;">32</td> <td style="text-align: center;">33</td> <td style="text-align: center;">2E</td> <td style="text-align: center;">34</td> <td style="text-align: center;">35</td> <td style="text-align: center;">30</td> </tr> <tr> <td style="text-align: center;">VD2</td> <td></td> <td></td> <td style="text-align: center;">VB10</td> <td style="text-align: center;">VB11</td> <td style="text-align: center;">...</td> <td></td> <td></td> <td></td> <td></td> <td></td> <td></td> <td></td> </tr> </table>	123.45		RTA	20	20	20	31	32	33	2E	34	35	30	VD2			VB10	VB11	...								
123.45		RTA	20	20	20	31	32	33	2E	34	35	30															
VD2			VB10	VB11	...																						

String Conversion Instructions

Converting Numerical Values to String

The Integer to String (ITS), Double Integer to String (DTS), and Real to String (RTS) instructions convert integers, double integers, or real number values (IN) to an ASCII string (OUT).

Operation of the Integer to String

The Integer to String instruction (ITS) converts an integer word IN to an ASCII string with a length of 8 characters. The format (FMT) specifies the conversion precision to the right of the decimal, and whether the decimal point is to be shown as a comma or a period. The resulting string is written to 9 consecutive bytes starting at OUT. See the section, format for strings in Chapter 4 for more information.

Error conditions that set ENO = 0

- 0006 (indirect address)
- 0091 (operand out of range)
- Illegal format (nnn > 5)

Figure 6-17 describes the format operand for the Integer to String instruction. The length of the output string is always 8 characters. The number of digits to the right of the decimal point in the output buffer is specified by the nnn field. The valid range of the nnn field is 0 to 5. Specifying 0 digits to the right of the decimal point causes the value to be displayed without a decimal point. For values of nnn greater than 5, the output is a string of 8 ASCII space characters. The c bit specifies the use of either a comma (c=1) or a decimal point (c=0) as the separator between the whole number and the fraction. The upper 4 bits of the format must be zero.

Figure 6-17 also shows examples of values that are formatted using a decimal point (c= 0) with three digits to the right of the decimal point (nnn = 011). The value at OUT is the length of the string.

The output string is formatted according to the following rules:

- Positive values are written to the output buffer without a sign.
- Negative values are written to the output buffer with a leading minus sign (–).
- Leading zeros to the left of the decimal point (except the digit adjacent to the decimal point) are suppressed.
- Values are right-justified in the output string.

Table 6-18 Valid Operands for the Instructions That Convert Numerical Values to Strings

Inputs/Outputs	Data Type	Operands
IN	BYTE (String) INT DINT REAL	VB, LB, *VD, *LD, *AC IW, QW, VW, MW, SMW, SW, T, C, LW, AIW, *VD, *LD, *AC, Constant ID, QD, VD, MD, SMD, SD, LD, AC, HC, *VD, *LD, *AC, Constant ID, QD, VD, MD, SMD, SD, LD, AC, *VD, *LD, *AC, Constant
INDX, FMT	BYTE	IB, QB, VB, MB, SMB, SB, LB, AC, *VD, *LD, *AC, Constant
OUT	BYTE (String) INT DINT, REAL	VB, LB, *VD, *LD, *AC IW, QW, VW, MW, SMW, SW, T, C, LW, AC, AQW, *VD, *LD, *AC ID, QD, VD, MD, SMD, SD, LD, AC, *VD, *LD, *AC

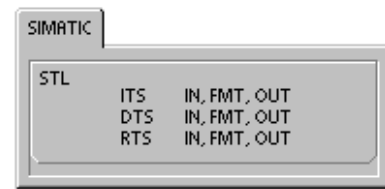
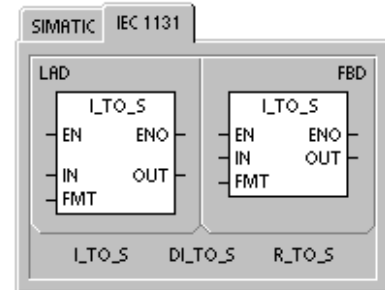
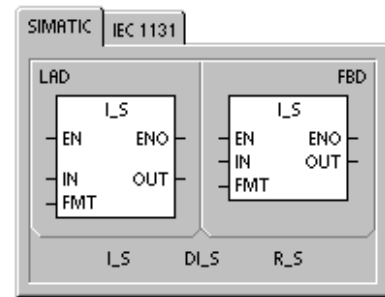

FMT								Out	Out	Out	Out	Out	Out	Out	Out	Out		
MSB	7	6	5	4	3	2	1	0	LSB	+1	+2	+3	+4	+5	+6	+7	+8	
	0	0	0	0	c	n	n	n	in=12	8			0	.	0	1	2	
									in=-123	8			0	.	1	2	3	
									in=1234	8			1	.	2	3	4	
									in = -12345	8		-	1	2	.	3	4	5

c = comma (1) or decimal point (0)
 nnn = digits to right of decimal point

Figure 6-17 FMT Operand for the Integer to String Instruction

Operation of the Double Integer to String

The Double Integer to String instruction (DTS) converts a double integer IN to an ASCII string with a length of 12 characters. The format (FMT) specifies the conversion precision to the right of the decimal, and whether the decimal point is to be shown as a comma or a period. The resulting string is written to 13 consecutive bytes starting at OUT. For more information, see the section that describes the format for strings in Chapter 4.

Error conditions that set ENO = 0

- 0006 (indirect address)
- 0091 (operand out of range)
- Illegal format (nnn > 5)

Figure 6-18 describes the format operand for the Integer to String instruction. The length of the output string is always 8 characters. The number of digits to the right of the decimal point in the output buffer is specified by the nnn field. The valid range of the nnn field is 0 to 5. Specifying 0 digits to the right of the decimal point causes the value to be displayed without a decimal point. For values of nnn greater than 5, the output is a string of 12 ASCII space characters. The c bit specifies the use of either a comma (c=1) or a decimal point (c=0) as the separator between the whole number and the fraction. The upper 4 bits of the format must be zero.

Figure 6-18 also shows examples of values that are formatted using a decimal point (c= 0) with four digits to the right of the decimal point (nnn = 100). The value at OUT is the length of the string. The output string is formatted according to the following rules:

- Positive values are written to the output buffer without a sign.
- Negative values are written to the output buffer with a leading minus sign (-).
- Leading zeros to the left of the decimal point (except the digit adjacent to the decimal point) are suppressed.
- Values are right-justified in the output string.

FMT													Out	Out	Out	Out	Out	Out	Out	Out	Out	Out	Out	Out
MSB	7	6	5	4	3	2	1	0	LSB	+1	+2	+3	+4	+5	+6	+7	+8	+9	+10	+11	+12			
	0	0	0	0	c	n	n	n	in=12	12				.	-	0	.	0	0	1	2			
									in=-1234567	12				1	2	3	.	4	5	6	7			

c = comma (1) or decimal point (0)
 nnn = digits to right of decimal point

Figure 6-18 FMT Operand for the Double Integer to String Instruction

Operation of the Real to String

The Real to String instruction (RTS) converts a real value IN to an ASCII string. The format (FMT) specifies the conversion precision to the right of the decimal, whether the decimal point is to be shown as a comma or a period and the length of the output string.

The resulting conversion is placed in a string beginning with OUT. The length of the resulting string is specified in the format and can be 3 to 15 characters. For more information, see the section that describes the format for strings in Chapter 4.

The real-number format used by the S7-200 supports a maximum of 7 significant digits. Attempting to display more than the 7 significant digits produces a rounding error.

Figure 6-19 describes the format operand for the Real to String instruction. The length of the output string is specified by the ssss field. A size of 0, 1, or 2 bytes is not valid. The number of digits to the right of the decimal point in the output buffer is specified by the nnn field. The valid range of the nnn field is 0 to 5. Specifying 0 digits to the right of the decimal point causes the value to be displayed without a decimal point. The output string is filled with ASCII space characters when nnn is greater than 5 or when the specified length of the output string is too small to store the converted value. The c bit specifies the use of either a comma (c=1) or a decimal point (c=0) as the separator between the whole number and the fraction.

Figure 6-19 also shows examples of values that are formatted using a decimal point (c = 0) with one digit to the right of the decimal point (nnn = 001) and a output string length of 6 characters (ssss = 0110). The value at OUT is the length of the string. The output string is formatted according to the following rules:

- Positive values are written to the output buffer without a sign.
- Negative values are written to the output buffer with a leading minus sign (-).
- Leading zeros to the left of the decimal point (except the digit adjacent to the decimal point) are suppressed.
- Values to the right of the decimal point are rounded to fit in the specified number of digits to the right of the decimal point.
- The size of the output string must be a minimum of three bytes more than the number of digits to the right of the decimal point.
- Values are right-justified in the output string.

FMT

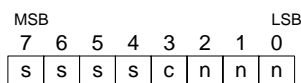

ssss = length of output string
 c = comma (1) or decimal point (0)
 nnn = digits to right of decimal point

	Out +1	Out +2	Out +3	Out +4	Out +5	Out +6
in=1234.5	6	1	2	3	4	.
in=-0.0004	6				0	.
in=-3.67526	6			-	3	.
in = 1.95	6				2	.

Figure 6-19 FMT Operand for the Real to String Instruction

Converting Substrings to Numerical Values

The Substring to Integer (STI), Substring to Double Integer (STD), and Substring to Real (STR) instructions convert a string value IN, starting at the offset INDX, to an integer, double integer or real number value OUT.

Error conditions that set ENO = 0

- 0006 (indirect address)
- 0091 (operand out of range)
- 009B (index = 0)
- SM1.1 (overflow)

The Substring to Integer and Substring to Double Integer convert strings with the following form: [spaces] [+ or -] [digits 0 – 9]

The Substring to Real instruction converts strings with the following form: [spaces] [+ or -] [digits 0 – 9] [. or .] [digits 0 – 9]

The INDX value is normally set to 1, which starts the conversion with the first character of the string. The INDX value can be set to other values to start the conversion at different points within the string. This can be used when the input string contains text that is not part of the number to be converted. For example, if the input string is "Temperature: 77.8", you set INDX to a value of 13 to skip over the word "Temperature:" at the start of the string.

The Substring to Real instruction does not convert strings using scientific notation or exponential forms of real numbers. The instruction does not produce an overflow error (SM1.1) but converts the string to a real number up to the exponential and then terminates the conversion. For example, the string '1.234E6' converts without errors to a real value of 1.234.

The conversion is terminated when the end of the string is reached or when the first invalid character is found. An invalid character is any character which is not a digit (0 – 9).

The overflow error (SM1.1) is set whenever the conversion produces an integer value that is too large for the output value. For example, the Substring to Integer instruction sets the overflow error if the input string produces a value greater than 32767 or less than -32768.

The overflow error (SM1.1) is also set if no conversion is possible when the input string does not contain a valid value. For example, if the input string contains 'A123', the conversion instruction sets SM1.1 (overflow) and the output value remains unchanged.

Table 6-19 Valid Operands for the Instructions That Convert Substrings to Numerical Values

Inputs/Outputs	Data Type	Operands
IN	BYTE (string)	IB, QB, VB, MB, SMB, SB, LB, *VD, *LD, *AC, Constant
INDX	BYTE	VB, IB, QB, MB, SMB, SB, LB, AC, *VD, *LD, *AC, Constant
OUT	BYTE (string)	VB, IB, QB, MB, SMB, SB, LB, *VD, *LD, *AC, Constant
	INT	VW, IW, QW, MW, SMW, SW, T, C, LW, AC, AQW, *VD, *LD, *AC
	DINT, REAL	VD, ID, QD, MD, SMD, SD, LD, AC, *VD, *LD, *AC

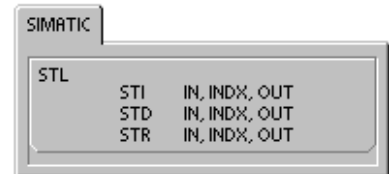
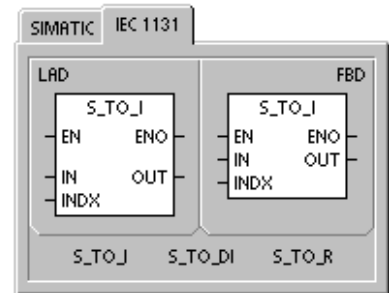
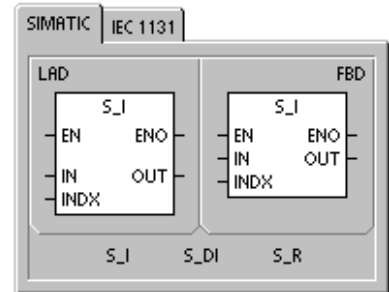

Valid Input Strings for Integer and Double Integer

Input String	Output Integer
'123'	123
'-00456'	-456
'123.45'	123
'+2345'	2345
'000000123ABCD'	123

Valid Input Strings for Real Numbers

Input String	Output Real
'123'	123.0
'-00456'	-456.0
'123.45'	123.45
'+2345'	2345.0
'00.000000123'	0.000000123

Invalid Input Strings

Input String
'A123'
' '
'++123'
'+-123'
'+ 123'

Figure 6-20 Examples of Valid and Invalid Input Strings

6

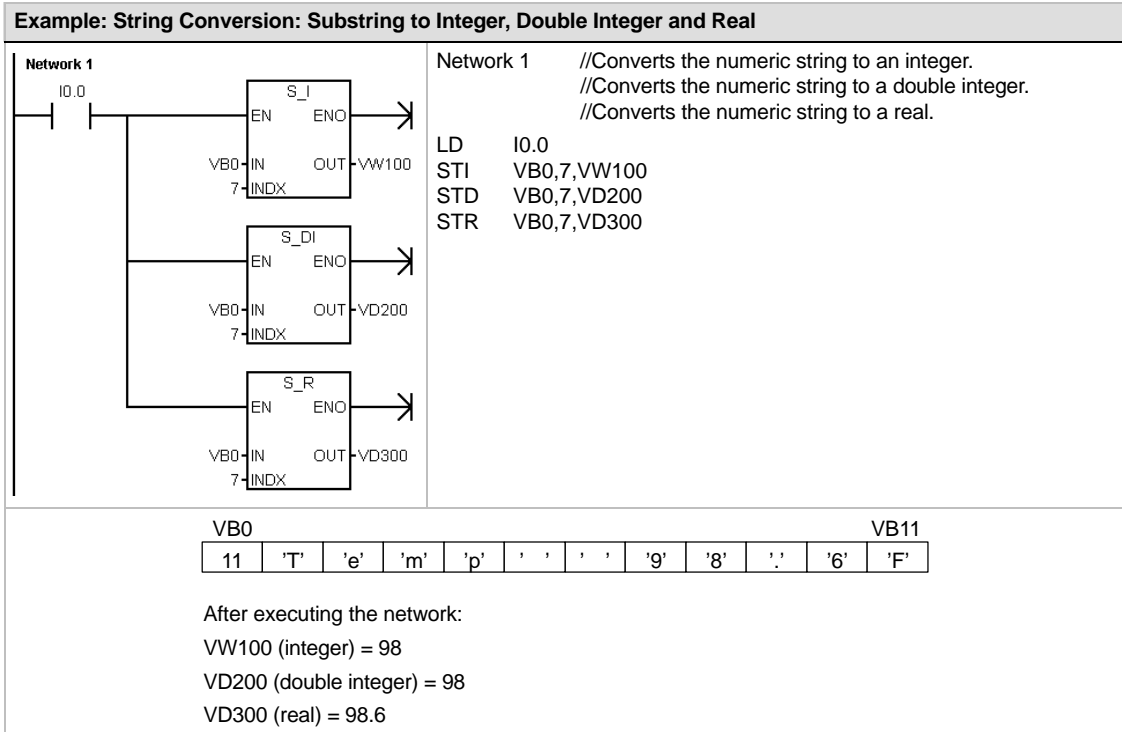

Encode and Decode Instructions

Encode

The Encode instruction (ENCO) writes the bit number of the least significant bit set of the input word IN into the least significant “nibble” (4 bits) of the output byte OUT.

Decode

The Decode instruction (DECO) sets the bit in the output word OUT that corresponds to the bit number represented by the least significant “nibble” (4 bits) of the input byte IN. All other bits of the output word are set to 0.

SM Bits and ENO

For both the Encode and Decode instructions, the following conditions affect ENO.

Error conditions that set ENO = 0

- 0006 (indirect address)

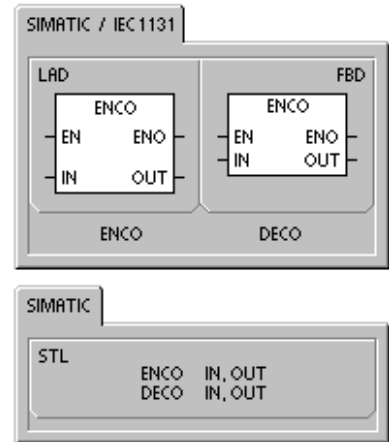

Table 6-20 Valid Operands for the Encode and Decode Instructions

Inputs/Outputs	Data Types	Operands
IN	BYTE	IB, QB, VB, MB, SMB, SB, LB, AC, *VD, *LD, *AC, Constant
	WORD	IW, QW, VW, MW, SMW, SW, T, C, LW, AC, AIW, *VD, *LD, *AC, Constant
OUT	BYTE	IB, QB, VB, MB, SMB, SB, LB, AC, *VD, *LD, *AC
	WORD	IW, QW, VW, MW, SMW, SW, T, C, LW, AC, AQW, *VD, *LD, *AC

Example: Decode and Encode Instructions

Network 1

Network 1

```
//AC2 contains error bits.
//1. The DECO instruction sets the bit in VW40
// that corresponds to this error code.
//2. The ENCO instruction converts
// the least significant bit set to an error code
// that is stored in VB50.

LD      I3.1
DECO   AC2, VW40
ENCO   AC3, VB50
```

AC2		15	9	0	
	DECO	3			AC3
		15	9	0	VB50
VW40		0000 0000 0000 1000			1000 0010 0000 0000

Counter Instructions

SIMATIC Counter Instructions

Count Up Counter

The Count Up instruction (CTU) counts up from the current value each time the count up (CU) input makes the transition from off to on. When the current value Cxx is greater than or equal to the preset value PV, the counter bit Cxx turns on. The counter is reset when the Reset (R) input turns on, or when the Reset instruction is executed. The counter stops counting when it reaches the maximum value (32,767).

STL operation :

- Reset input: Top of stack
- Count Up input: Value loaded in the second stack location

Count Down Counter

The Count Down instruction (CTD) counts down from the current value of that counter each time the count down (CD) input makes the transition from off to on. When the current value Cxx is equal to 0, the counter bit Cxx turns on. The counter resets the counter bit Cxx and loads the current value with the preset value PV when the load input LD turns on. The counter stops upon reaching zero, and the counter bit Cxx turns on.

STL operation:

- Load input: Top of stack
- Count Down input: Value loaded in the second stack location.

Count Up/Down Counter

The Count Up/Down instruction (CTUD) counts up each time the count up (CU) input makes the transition from off to on, and counts down each time the count down (CD) input makes the transition from off to on. The current value Cxx of the counter maintains the current count. The preset value PV is compared to the current value each time the counter instruction is executed.

Upon reaching maximum value (32,767), the next rising edge at the count up input causes the current count to wrap around to the minimum value (−32,768). On reaching the minimum value (−32,768), the next rising edge at the count down input causes the current count to wrap around to the maximum value (32,767).

When the current value Cxx is greater than or equal to the preset value PV, the counter bit Cxx turns on. Otherwise, the counter bit turns off. The counter is reset when the Reset (R) input turns on, or when the Reset instruction is executed. The CTUD counter stops counting when it reaches PV.

STL operation:

- Reset input: Top of stack
- Count Down input: Value loaded in the second stack location
- Count Up input: Value loaded in the third stack location

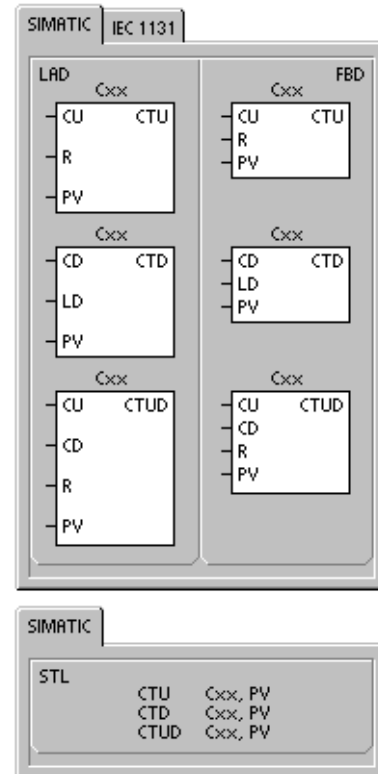

Table 6-21 Valid Operands for the SIMATIC Counter Instructions

Inputs/Outputs	Data Types	Operands
Cxx	WORD	Constant (C0 to C255)
CU, CD, LD, R	BOOL	I, Q, V, M, SM, S, T, C, L, Power Flow
PV	INT	IW, QW, VW, MW, SMW, SW, LW, T, C, AC, AIW, *VD, *LD, *AC, Constant

**Tip**

Since there is one current value for each counter, do not assign the same number to more than one counter. (Up Counters, Up/Down Counters, and Down counters with the same number access the same current value.)

When you reset a counter using the Reset instruction, the counter bit is reset and the counter current value is set to zero. Use the counter number to reference both the current value and the counter bit of that counter.

Table 6-22 Operations of the Counter Instructions

Type	Operation	Counter Bit	Power Cycle/First Scan
CTU	CU increments the current value. Current value continues to increment until it reaches 32,767.	The counter bit turns on when: Current value \geq Preset	Counter bit is off. Current value can be retained. ¹
CTUD	CU increments the current value. CD decrements the current value. Current value continues to increment or decrement until the counter is reset.	The counter bit turns on when: Current value \geq Preset	Counter bit is off. Current value can be retained. ¹
CTD	CD decrements the current value until the current value reaches 0.	The counter bit turns on when: Current value = 0	Counter bit is off. Current value can be retained. ¹

¹ You can select that the current value for the counter be retentive. See Chapter 4 for information about memory retention for the S7-200 CPU.

Example: SIMATIC Count Down Counter Instruction

<p>Network 1</p> <p>Network 2</p>	<pre> Network 1 //Count down counter C1 current value counts from 3 to 0 //with I0.1 off, //I0.0 Off-on decrements C1 current value //I0.1 On loads countdown preset value 3 LD I0.0 LD I0.1 CTD C1, +3 Network 2 //C1 bit is on when counter C1 current value = 0 LD C1 = Q0.0 </pre>
---	---

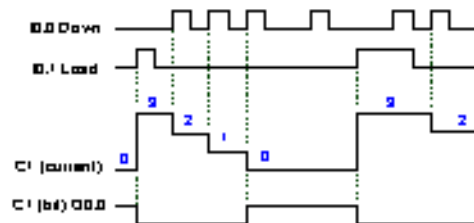
Timing Diagram

6

Example: SIMATIC Count Up/Down Counter Instruction

Network 1

Network 2

Network 1 //I0.0 counts up
//I0.1 counts down
//I0.2 resets current value to 0

```
LD I0.0
LD I0.1
LD I0.2
CTUD C48, +4
```

Network 2 //Count Up/Down counter C48 turns on C48 bit
//when current value >= 4

```
LD C48
= Q0.0
```

Timing Diagram

IEC Counter Instructions

Up Counter

The Count Up instruction (CTU) counts up from the current value to the preset value (PV) on the rising edges of the Count Up (CU) input. When the current value (CV) is greater than or equal to the preset value, the counter output bit (Q) turns on. The counter resets when the reset input (R) is enabled. The Up Counter stops counting when it reaches the preset value.

Down Counter

The Count Down instruction (CTD) counts down from the preset value (PV) on the rising edges of the Count Down (CD) input. When the current value (CV) is equal to zero, the counter output bit (Q) turns on. The counter resets and loads the current value with the preset value when the load input (LD) is enabled. The Down Counter stops counting when it reaches zero.

Up/Down Counter

The Count Up/Down instruction (CTUD) counts up or down from the current value (CV) on the rising edges of the Count Up (CU) or Count Down (CD) input. When the current value is equal to preset, the up output (QU) turns on. When the current value is equal to zero, the down output (QD) turns on. The counter loads the current value with the preset value (PV) when the load (LD) input is enabled. Similarly, the counter resets and loads the current value with 0 when the reset (R) is enabled. The counter stops counting when it reaches preset or 0.

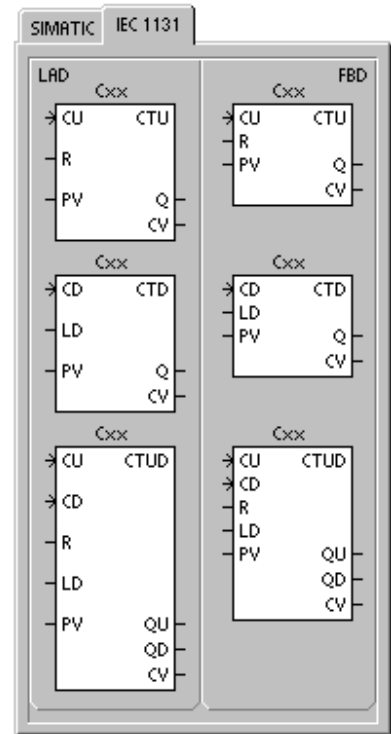

Table 6-23 Valid Operands for the IEC Counter Instructions

Inputs/Outputs	Data Types	Operands
Cxx	CTU, CTD, CTUD	Constant (C0 to C255)
CU, CD, LD, R	BOOL	I, Q, V, M, SM, S, T, C, L, Power Flow
PV	INT	IW, QW, VW, MW, SMW, SW, LW, AC, AIW, *VD, *LD, *AC, Constant
Q, QU, QD	BOOL	I, Q, V, M, SM, S, L
CV	INT	IW, QW, VW, MW, SW, LW, AC, *VD, *LD, *AC



Tip

Since there is one current value for each counter, do not assign the same number to more than one counter. (Up Counters, Down Counters, and Up/Down Counters access the same current value.)

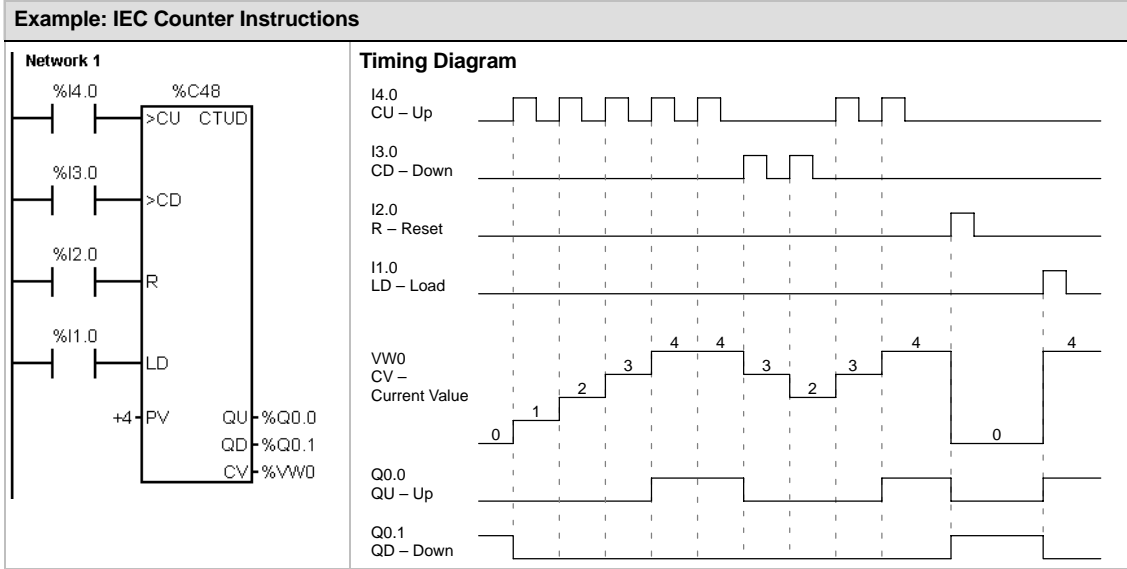

High-Speed Counter Instructions

High-Speed Counter Definition

The High-Speed Counter Definition instruction (HDEF) selects the operating mode of a specific high-speed counter (HSCx). The mode selection defines the clock, direction, start, and reset functions of the high-speed counter.

You use one High-Speed Counter Definition instruction for each high-speed counter.

Error conditions that set ENO = 0

- 0003 (input point conflict)
- 0004 (illegal instruction in interrupt)
- 000A (HSC redefinition)

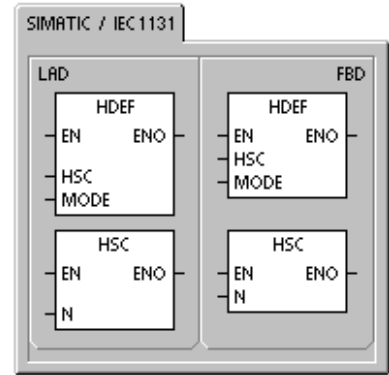

High-Speed Counter

The High-Speed Counter (HSC) instruction configures and controls the high-speed counter, based on the state of the HSC special memory bits. The parameter N specifies the high-speed counter number.

The high-speed counters can be configured for up to twelve different modes of operation. See Table 6-25.

Each counter has dedicated inputs for clocks, direction control, reset, and start, where these functions are supported. For the two-phase counters, both clocks can run at their maximum rates. In quadrature modes, you can select one times (1x) or four times (4x) the maximum counting rates. All counters run at maximum rates without interfering with one another.

Error conditions that set ENO = 0

- 0001 (HSC before HDEF)
- 0005 (simultaneous HSC/PLS)

Table 6-24 Valid Operands for the High-Speed Counter Instructions

Inputs/Outputs	Data Types	Operands
HSC, MODE	BYTE	Constant
N	WORD	Constant



Tips and Tricks

Refer to the *Tips and Tricks* on the documentation CD for programs that use high-speed counters. See *Tip 4* and *Tip 29*.

High-speed counters count high-speed events that cannot be controlled at S7-200 scan rates. The maximum counting frequency of a high-speed counter depends upon your S7-200 CPU model. Refer to Appendix A for more information.



Tip

CPU 221 and CPU 222 support four high-speed counters: HSC0, HSC3, HSC4, and HSC5. These CPUs do not support HSC1 and HSC2.

CPU 224, CPU 226, and CPU 226XM support six high-speed counters: HSC0 to HSC5.

Typically, a high-speed counter is used as the drive for a drum timer, where a shaft rotating at a constant speed is fitted with an incremental shaft encoder. The shaft encoder provides a specified number of counts per revolution and a reset pulse that occurs once per revolution. The clock(s) and the reset pulse from the shaft encoder provide the inputs to the high-speed counter.

The high-speed counter is loaded with the first of several presets, and the desired outputs are activated for the time period where the current count is less than the current preset. The counter is set up to provide an interrupt when the current count is equal to preset and also when reset occurs.

As each current-count-value-equals-preset-value interrupt event occurs, a new preset is loaded and the next state for the outputs is set. When the reset interrupt event occurs, the first preset and the first output states are set, and the cycle is repeated.

Since the interrupts occur at a much lower rate than the counting rates of the high-speed counters, precise control of high-speed operations can be implemented with relatively minor impact to the overall PLC scan cycle. The method of interrupt attachment allows each load of a new preset to be performed in a separate interrupt routine for easy state control. (Alternatively, all interrupt events can be processed in a single interrupt routine.)

6

Understanding the Different High-Speed Counters

All counters function the same way for the same counter mode of operation. There are four basic types of counters: single-phase counter with internal direction control, single-phase counter with external direction control, two-phase counter with 2 clock inputs, and A/B phase quadrature counter. Note that every mode is not supported by every counter. You can use each type: without reset or start inputs, with reset and without start, or with both start and reset inputs.

- When you activate the reset input, it clears the current value and holds it clear until you deactivate reset.
- When you activate the start input, it allows the counter to count. While start is deactivated, the current value of the counter is held constant and clocking events are ignored.
- If reset is activated while start is inactive, the reset is ignored and the current value is not changed. If the start input becomes active while the reset input is active, the current value is cleared.

Before you use a high-speed counter, you use the HDEF instruction (High-Speed Counter Definition) to select a counter mode. Use the first scan memory bit, SM0.1 (this bit is turned on for the first scan and is then turned off), to call a subroutine that contains the HDEF instruction.

Programming a High-Speed Counter



Instruction
Wizard

You can use the HSC Instruction Wizard to configure the counter. The wizard uses the following information: type and mode of counter, counter preset value, counter current value, and initial counting direction. To start the HSC Instruction Wizard, select the **Tools > Instruction Wizard** menu command and then select HSC from the Instruction Wizard window.

To program a high-speed counter, you must perform the following basic tasks:

- Define the counter and mode.
- Set the control byte.
- Set the current value (starting value).
- Set the preset value (target value).
- Assign and enable the interrupt routine.
- Activate the high-speed counter.

Defining Counter Modes and Inputs

Use the High-Speed Counter Definition instruction to define the counter modes and inputs.

Table 6-25 shows the inputs used for the clock, direction control, reset, and start functions associated with the high-speed counters. The same input cannot be used for two different functions, but any input not being used by the present mode of its high-speed counter can be used for another purpose. For example, if HSC0 is being used in mode 1, which uses I0.0 and I0.2, I0.1 can be used for edge interrupts or for HSC3.



Tip

Note that all modes of HSC0 always use I0.0 and all modes of HSC4 always use I0.3, so these points are never available for other uses when these counters are in use.

Table 6-25 Inputs for the High-Speed Counters

Mode	Description	Inputs			
	HSC0	I0.0	I0.1	I0.2	
	HSC1	I0.6	I0.7	I0.2	I1.1
	HSC2	I1.2	I1.3	I1.1	I1.2
	HSC3	I0.1			
	HSC4	I0.3	I0.4	I0.5	
	HSC5	I0.4			
0	Single-phase counter with internal direction control	Clock			
1		Clock		Reset	
2		Clock		Reset	Start
3	Single-phase counter with external direction control	Clock	Direction		
4		Clock	Direction	Reset	
5		Clock	Direction	Reset	Start
6	Two-phase counter with 2 clock inputs	Clock Up	Clock Down		
7		Clock Up	Clock Down	Reset	
8		Clock Up	Clock Down	Reset	Start
9	A/B phase quadrature counter	Clock A	Clock B		
10		Clock A	Clock B	Reset	
11		Clock A	Clock B	Reset	Start

Examples of HSC Modes

The timing diagrams in Figure 6-21 through Figure 6-25 show how each counter functions according to mode.

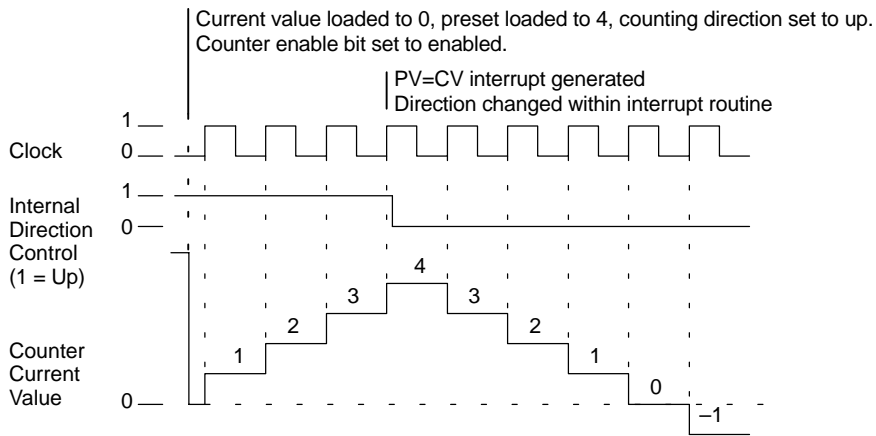

Figure 6-21 Operation Example of Modes 0, 1, or 2

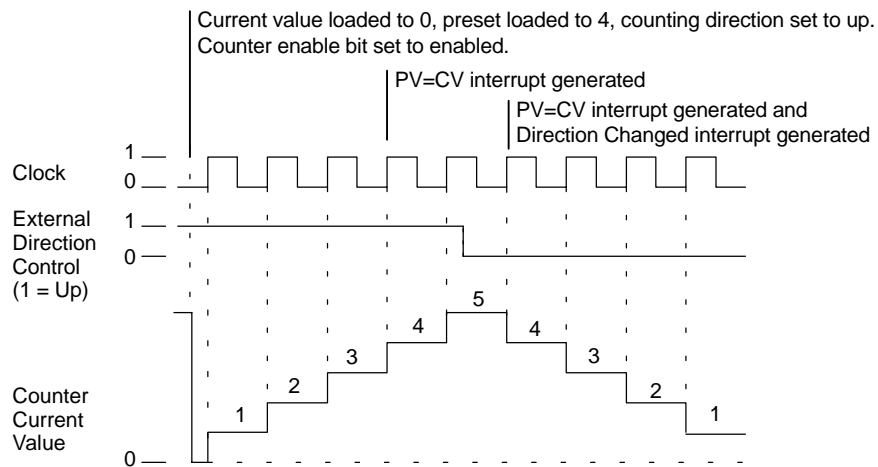

Figure 6-22 Operation Example of Modes 3, 4, or 5

When you use counting modes 6, 7, or 8, and rising edges on both the up clock and down clock inputs occur within 0.3 microseconds of each other, the high-speed counter could see these events as happening simultaneously. If this happens, the current value is unchanged and no change in counting direction is indicated. As long as the separation between rising edges of the up and down clock inputs is greater than this time period, the high-speed counter captures each event separately. In either case, no error is generated and the counter maintains the correct count value.

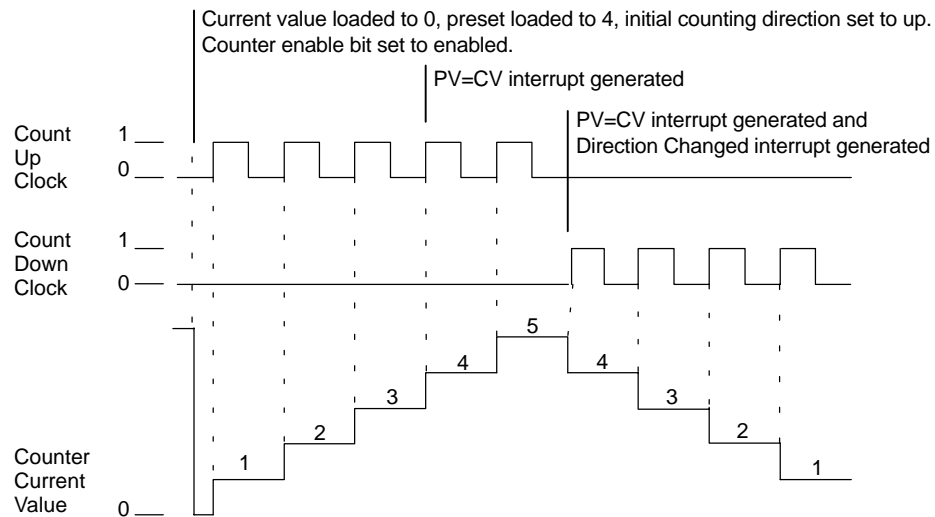

Figure 6-23 Operation Example of Modes 6, 7, or 8

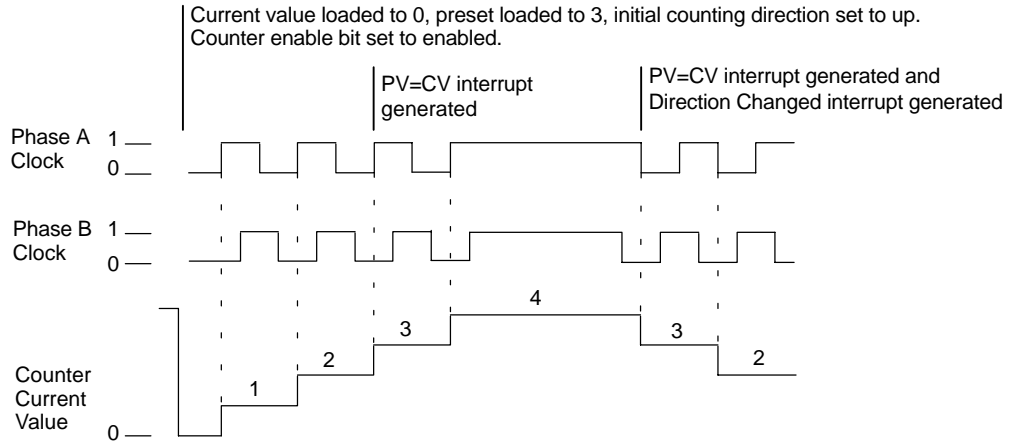

Figure 6-24 Operation Example of Modes 9, 10, or 11 (Quadrature 1x Mode)

6

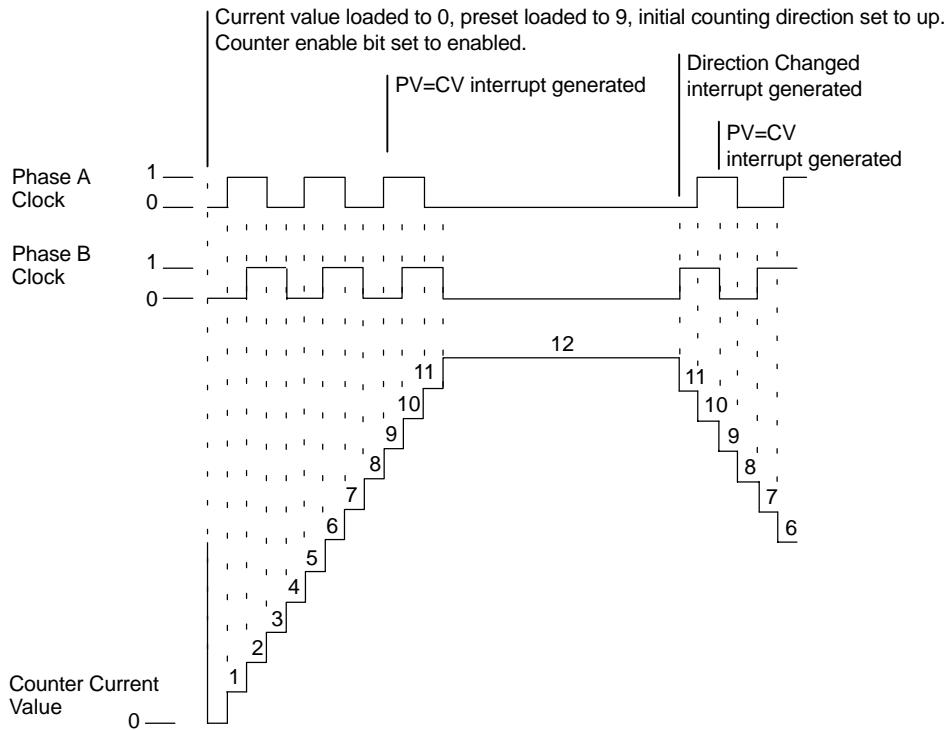

Figure 6-25 Operation Example of Modes 9, 10, or 11 (Quadrature 4x Mode)

Reset and Start Operation

The operation of the reset and start inputs shown in Figure 6-26 applies to all modes that use reset and start inputs. In the diagrams for the reset and start inputs, both reset and start are shown with the active state programmed to a high level.

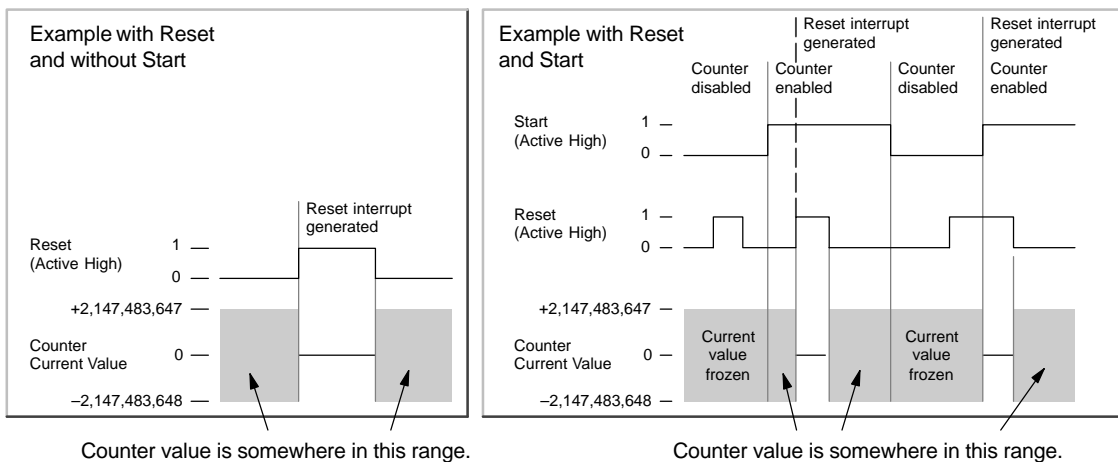

Figure 6-26 Operation Examples Using Reset with and without Start

Four counters have three control bits that are used to configure the active state of the reset and start inputs and to select 1x or 4x counting modes (quadrature counters only). These bits are located in the control byte for the respective counter and are only used when the HDEF instruction is executed. These bits are defined in Table 6-26.



Tip

You must set these three control bits to the desired state before the HDEF instruction is executed. Otherwise, the counter takes on the default configuration for the counter mode selected.

Once the HDEF instruction has been executed, you cannot change the counter setup unless you first place the S7-200 in STOP mode.

Table 6-26 Active Level for Reset, Start, and 1x/4x Control Bits

HSC0	HSC1	HSC2	HSC4	Description (used only when HDEF is executed)
SM37.0	SM47.0	SM57.0	SM147.0	Active level control bit for Reset ¹ : 0 = Reset is active high 1 = Reset is active low
—	SM47.1	SM57.1	—	Active level control bit for Start ¹ : 0 = Start is active high 1 = Start is active low
SM37.2	SM47.2	SM57.2	SM147.2	Counting rate selection for quadrature counters: 0 = 4X counting rate 1 = 1X counting rate

¹ The default setting of the reset input and the start input are active high, and the quadrature counting rate is 4x (or four times the input clock frequency).

Example: High-Speed Counter Definition Instruction

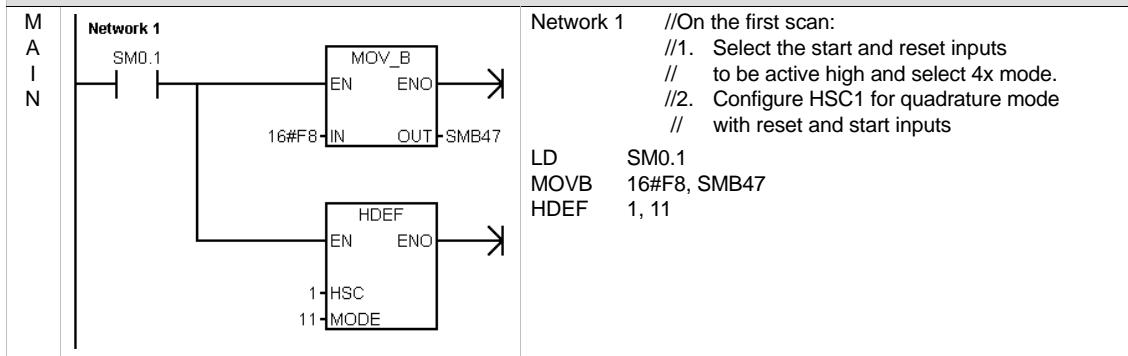

Setting the Control Byte

After you define the counter and the counter mode, you can program the dynamic parameters of the counter. Each high-speed counter has a control byte that allows the following actions:

- Enabling or disabling the counter
- Controlling the direction (modes 0, 1, and 2 only), or the initial counting direction for all other modes
- Loading the current value
- Loading the preset value

Examination of the control byte and associated current and preset values is invoked by the execution of the HSC instruction. Table 6-27 describes each of these control bits.

Table 6-27 Control Bits for HSC0, HSC1, HSC2, HSC3, HSC4, and HSC5

HSC0	HSC1	HSC2	HSC3	HSC4	HSC5	Description
SM37.3	SM47.3	SM57.3	SM137.3	SM147.3	SM157.3	Counting direction control bit: 0 = Count down 1 = Count up
SM37.4	SM47.4	SM57.4	SM137.4	SM147.4	SM157.4	Write the counting direction to the HSC: 0 = No update 1 = Update direction
SM37.5	SM47.5	SM57.5	SM137.5	SM147.5	SM157.5	Write the new preset value to the HSC: 0 = No update 1 = Update preset
SM37.6	SM47.6	SM57.6	SM137.6	SM147.6	SM157.6	Write the new current value to the HSC: 0 = No update 1 = Update current value
SM37.7	SM47.7	SM57.7	SM137.7	SM147.7	SM157.7	Enable the HSC: 0 = Disable the HSC 1 = Enable the HSC

Setting Current Values and Preset Values

Each high-speed counter has a 32-bit current value and a 32-bit preset value. Both the current and the preset values are signed integer values. To load a new current or preset value into the high-speed counter, you must set up the control byte and the special memory bytes that hold the current and/or preset values, and also execute the HSC instruction to cause the new values to be transferred to the high-speed counter. Table 6-28 lists the special memory bytes used to hold the new current and preset values.

In addition to the control bytes and the new preset and current holding bytes, the current value of each high-speed counter can only be read using the data type HC (High-Speed Counter Current) followed by the number (0, 1, 2, 3, 4, or 5) of the counter. The current value is directly accessible for read operations, but can only be written with the HSC instruction.

Table 6-28 Current and Preset Values of HSC0, HSC1, HSC2, HSC3, HSC4, and HSC5

Value to be Loaded	HSC0	HSC1	HSC2	HSC3	HSC4	HSC5
New current	SMD38	SMD48	SMD58	SMD138	SMD148	SMD158
New preset	SMD42	SMD52	SMD62	SMD142	SMD152	SMD162

Addressing the High-Speed Counters (HC)

To access the count value for the high-speed counter, specify the address of the high-speed counter, using the memory type (HC) and the counter number (such as HC0). The current value of the high-speed counter is a read-only value that can be addressed only as a double word (32 bits), as shown in Figure 6-27.

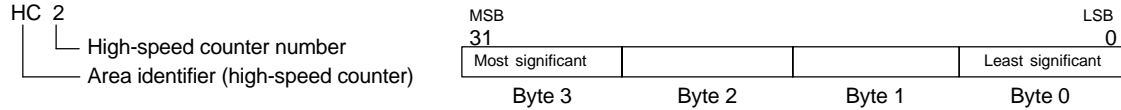

Figure 6-27 Accessing the High-Speed Counter Current Values

Assigning Interrupts

All counter modes support an interrupt on current value equal to the preset value. Counter modes that use an external reset input support an interrupt on activation of the external reset. All counter modes except modes 0, 1, and 2 support an interrupt on a change in counting direction. Each of these interrupt conditions can be enabled or disabled separately. For a complete discussion on the use of interrupts, see the section on Communications and Interrupt instructions.

Notice

A fatal error can occur if you attempt either to load a new current value or to disable and then re-enable the high-speed counter from within the external reset interrupt routine.

Status Byte

A status byte for each high-speed counter provides status memory bits that indicate the current counting direction and whether the current value is greater or equal to the preset value. Table 6-29 defines these status bits for each high-speed counter.



Tip

Status bits are valid only while the high-speed counter interrupt routine is being executed. The purpose of monitoring the state of the high-speed counter is to enable interrupts for the events that are of consequence to the operation being performed.

Table 6-29 Status Bits for HSC0, HSC1, HSC2, HSC3, HSC4, and HSC5

HSC0	HSC1	HSC2	HSC3	HSC4	HSC5	Description
SM36.0	SM46.0	SM56.0	SM136.0	SM146.0	SM156.0	Not used
SM36.1	SM46.1	SM56.1	SM136.1	SM146.1	SM156.1	Not used
SM36.2	SM46.2	SM56.2	SM136.2	SM146.2	SM156.2	Not used
SM36.3	SM46.3	SM56.3	SM136.3	SM146.3	SM156.3	Not used
SM36.4	SM46.4	SM56.4	SM136.4	SM146.4	SM156.4	Not used
SM36.5	SM46.5	SM56.5	SM136.5	SM146.5	SM156.5	Current counting direction status bit: 0 = Counting down 1 = Counting up
SM36.6	SM46.6	SM56.6	SM136.6	SM146.6	SM156.6	Current value equals preset value status bit: 0 = Not equal 1 = Equal
SM36.7	SM46.7	SM56.7	SM136.7	SM146.7	SM156.7	Current value greater than preset value status bit: 0 = Less than or equal 1 = Greater than

Sample Initialization Sequences for the High-Speed Counters

HSC1 is used as the model counter in the following descriptions of the initialization and operation sequences. The initialization descriptions assume that the S7-200 has just been placed in RUN mode, and for that reason, the first scan memory bit is true. If this is not the case, remember that the HDEF instruction can be executed only one time for each high-speed counter after entering RUN mode. Executing HDEF for a high-speed counter a second time generates a run-time error and does not change the counter setup from the way it was set up on the first execution of HDEF for that counter.



Tip

Although the following sequences show how to change direction, current value, and preset value individually, you can change all or any combination of them in the same sequence by setting the value of SMB47 appropriately and then executing the HSC instruction.

Initialization Modes 0, 1, or 2

The following steps describe how to initialize HSC1 for Single Phase Up/Down Counter with Internal Direction (Modes 0, 1, or 2).

6

1. Use the first scan memory bit to call a subroutine in which the initialization operation is performed. Since you use a subroutine call, subsequent scans do not make the call to the subroutine, which reduces scan time execution and provides a more structured program.
2. In the initialization subroutine, load SMB47 according to the desired control operation. For example:

SMB47 = 16#F8	<i>Produces the following results:</i>
	Enables the counter
	Writes a new current value
	Writes a new preset value
	Sets the direction to count up
	Sets the start and reset inputs to be active high
3. Execute the HDEF instruction with the HSC input set to 1 and the MODE input set to one of the following: 0 for no external reset or start, 1 for external reset and no start, or 2 for both external reset and start.
4. Load SMD48 (double-word-sized value) with the desired current value (load with 0 to clear it).
5. Load SMD52 (double-word-sized value) with the desired preset value.
6. In order to capture the current value equal to preset event, program an interrupt by attaching the CV = PV interrupt event (event 13) to an interrupt routine. See the section that discusses the Interrupt Instructions for complete details on interrupt processing.
7. In order to capture an external reset event, program an interrupt by attaching the external reset interrupt event (event 15) to an interrupt routine.
8. Execute the global interrupt enable instruction (ENI) to enable interrupts.
9. Execute the HSC instruction to cause the S7-200 to program HSC1.
10. Exit the subroutine.

Initialization Modes 3, 4, or 5

The following steps describe how to initialize HSC1 for Single Phase Up/Down Counter with External Direction (Modes 3, 4, or 5):

1. Use the first scan memory bit to call a subroutine in which the initialization operation is performed. Since you use a subroutine call, subsequent scans do not make the call to the subroutine, which reduces scan time execution and provides a more structured program.
2. In the initialization subroutine, load SMB47 according to the desired control operation. For example:

SMB47 = 16#F8	<i>Produces the following results:</i>
	Enables the counter
	Writes a new current value
	Writes a new preset value
	Sets the initial direction of the HSC to count up
	Sets the start and reset inputs to be active high
3. Execute the HDEF instruction with the HSC input set to 1 and the MODE input set to one of the following: 3 for no external reset or start, 4 for external reset and no start, or 5 for both external reset and start.
4. Load SMD48 (double-word-sized value) with the desired current value (load with 0 to clear it).
5. Load SMD52 (double-word-sized value) with the desired preset value.
6. In order to capture the current-value-equal-to-preset event, program an interrupt by attaching the CV = PV interrupt event (event 13) to an interrupt routine. See the section that discusses the Interrupt Instructions for complete details on interrupt processing.
7. In order to capture direction changes, program an interrupt by attaching the direction changed interrupt event (event 14) to an interrupt routine.
8. In order to capture an external reset event, program an interrupt by attaching the external reset interrupt event (event 15) to an interrupt routine.
9. Execute the global interrupt enable instruction (ENI) to enable interrupts.
10. Execute the HSC instruction to cause the S7-200 to program HSC1.
11. Exit the subroutine.

Initialization Modes 6, 7, or 8

The following steps describe how to initialize HSC1 for Two Phase Up/Down Counter with Up/Down Clocks (Modes 6, 7, or 8):

1. Use the first scan memory bit to call a subroutine in which the initialization operations are performed. Since you use a subroutine call, subsequent scans do not make the call to the subroutine, which reduces scan time execution and provides a more structured program.
2. In the initialization subroutine, load SMB47 according to the desired control operation. For example:

SMB47 = 16#F8	<i>Produces the following results:</i>
	Enables the counter
	Writes a new current value
	Writes a new preset value
	Sets the initial direction of the HSC to count up
	Sets the start and reset inputs to be active high
3. Execute the HDEF instruction with the HSC input set to 1 and the MODE set to one of the following: 6 for no external reset or start, 7 for external reset and no start, or 8 for both external reset and start.
4. Load SMD48 (double-word-sized value) with the desired current value (load with 0 to clear it).
5. Load SMD52 (double-word-sized value) with the desired preset value.
6. In order to capture the current-value-equal-to-preset event, program an interrupt by attaching the CV = PV interrupt event (event 13) to an interrupt routine. See the section on interrupts.

7. In order to capture direction changes, program an interrupt by attaching the direction changed interrupt event (event 14) to an interrupt routine.
8. In order to capture an external reset event, program an interrupt by attaching the external reset interrupt event (event 15) to an interrupt routine.
9. Execute the global interrupt enable instruction (ENI) to enable interrupts.
10. Execute the HSC instruction to cause the S7-200 to program HSC1.
11. Exit the subroutine.

Initialization Modes 9, 10, or 11

The following steps describe how to initialize HSC1 for A/B Phase Quadrature Counter (for modes 9, 10, or 11):

1. Use the first scan memory bit to call a subroutine in which the initialization operations are performed. Since you use a subroutine call, subsequent scans do not make the call to the subroutine, which reduces scan time execution and provides a more structured program.
2. In the initialization subroutine, load SMB47 according to the desired control operation.

Example (1x counting mode):

SMB47 = 16#FC	<i>Produces the following results:</i> Enables the counter Writes a new current value Writes a new preset value Sets the initial direction of the HSC to count up Sets the start and reset inputs to be active high
---------------	--

Example (4x counting mode):

SMB47 = 16#F8	<i>Produces the following results:</i> Enables the counter Writes a new current value Writes a new preset value Sets the initial direction of the HSC to count up Sets the start and reset inputs to be active high
---------------	--

3. Execute the HDEF instruction with the HSC input set to 1 and the MODE input set to one of the following: 9 for no external reset or start, 10 for external reset and no start, or 11 for both external reset and start.
4. Load SMD48 (double-word-sized value) with the desired current value (load with 0 to clear it).
5. Load SMD52 (double-word-sized value) with the desired preset value.
6. In order to capture the current-value-equal-to-preset event, program an interrupt by attaching the CV = PV interrupt event (event 13) to an interrupt routine. See the section on enabling interrupts (ENI) for complete details on interrupt processing.
7. In order to capture direction changes, program an interrupt by attaching the direction changed interrupt event (event 14) to an interrupt routine.
8. In order to capture an external reset event, program an interrupt by attaching the external reset interrupt event (event 15) to an interrupt routine.
9. Execute the global interrupt enable instruction (ENI) to enable interrupts.
10. Execute the HSC instruction to cause the S7-200 to program HSC1.
11. Exit the subroutine.

Change Direction in Modes 0, 1, or 2

The following steps describe how to configure HSC1 for Change Direction for Single Phase Counter with Internal Direction (Modes 0, 1, or 2):

1. Load SMB47 to write the desired direction:
SMB47 = 16#90 Enables the counter
 Sets the direction of the HSC to count down
SMB47 = 16#98 Enables the counter
 Sets the direction of the HSC to count up
2. Execute the HSC instruction to cause the S7-200 to program HSC1.

Loading a New Current Value (Any Mode)

Changing the current value forces the counter to be disabled while the change is made. While the counter is disabled, it does not count or generate interrupts.

The following steps describe how to change the counter current value of HSC1 (any mode):

1. Load SMB47 to write the desired current value:
SMB47 = 16#C0 Enables the counter
 Writes the new current value
2. Load SMD48 (double-word-sized value) with the desired current value (load with 0 to clear it).
3. Execute the HSC instruction to cause the S7-200 to program HSC1.

Loading a New Preset Value (Any Mode)

The following steps describe how to change the preset value of HSC1 (any mode):

1. Load SMB47 to write the desired preset value:
SMB47 = 16#A0 Enables the counter
 Writes the new preset value
2. Load SMD52 (double-word-sized value) with the desired preset value.
3. Execute the HSC instruction to cause the S7-200 to program HSC1.

Disabling a High-Speed Counter (Any Mode)

The following steps describe how to disable the HSC1 high-speed counter (any mode):

1. Load SMB47 to disable the counter:
SMB47 = 16#00 Disables the counter
2. Execute the HSC instruction to disable the counter.

Example: High-Speed Counter Instruction

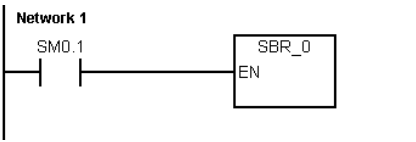
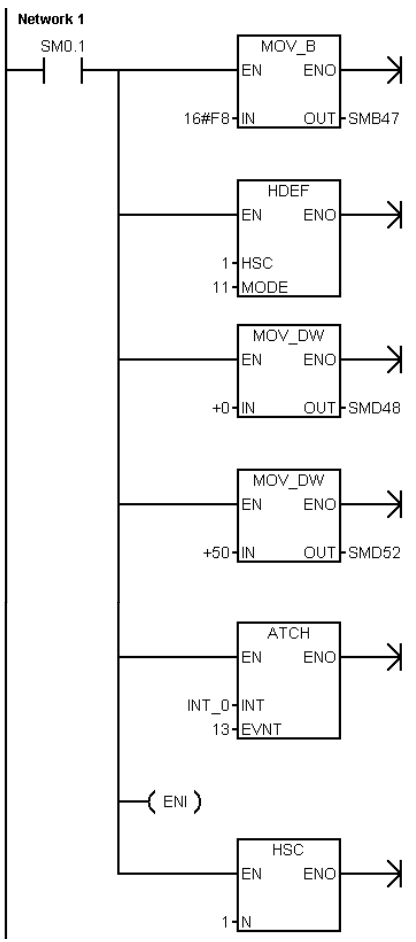
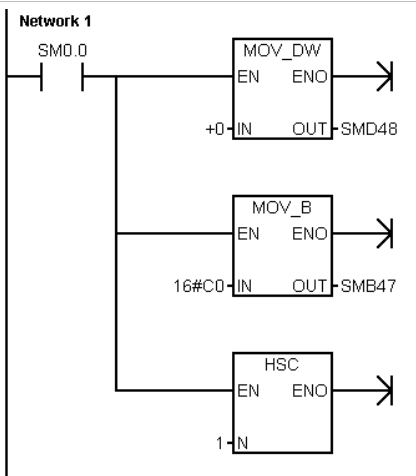
<p>M A I N</p>	<p>Network 1</p> 	<p>Network 1 //On the first scan, call SBR_0. LD SM0.1 CALL SBR_0</p>
<p>S B R 0</p>	<p>Network 1</p> 	<p>Network 1 //On the first scan, configure HSC1: //1. Enable the counter. // - Write a new current value. // - Write a new preset value. // - Set the initial direction to count up. // - Select the start and reset inputs to be active high. // - Select 4x mode. //2. Configure HSC1 for quadrature mode // with reset and start inputs. //3. Clear the current value of HSC1. //4. Set the HSC1 preset value to 50. //5. When HSC1 current value = preset value, // attach event 13 to interrupt routine INT_0. //6. Global interrupt enable. //7. Program HSC1. LD SM0.1 MOVB 16#F8, SMB47 HDEF 1, 11 MOVD +0, SMD48 MOVD +50, SMD52 ATCH INT_0, 13 ENI HSC 1</p>
<p>I N T 0</p>	<p>Network 1</p> 	<p>Network 1 //Program HSC1: //1. Clear the current value of HSC1. //2. Select to write only a new current // and leave HSC1 enabled. LD SM0.0 MOVD +0, SMD48 MOVB 16#C0, SMB47 HSC 1</p>

6

Pulse Output Instruction



Position Control

The Pulse Output instruction (PLS) is used to control the Pulse Train Output (PTO) and Pulse Width Modulation (PWM) functions available on the high-speed outputs (Q0.0 and Q0.1). You can use the Position Control wizard to configure the pulse outputs.

PTO provides a square wave (50% duty cycle) output with user control of the cycle time and the number of pulses.

PWM provides a continuous, variable duty cycle output with user control of the cycle time and the pulse width.

The S7-200 has two PTO/PWM generators that create either a high-speed pulse train or a pulse width modulated waveform. One generator is assigned to digital output point Q0.0, and the other generator is assigned to digital output point Q0.1. A designated special memory (SM) location stores the following data for each generator: a control byte (8-bit value), a pulse count value (an unsigned 32-bit value), and a cycle time and pulse width value (an unsigned 16-bit value).

The PTO/PWM generators and the process-image register share the use of Q0.0 and Q0.1. When a PTO or PWM function is active on Q0.0 or Q0.1, the PTO/PWM generator has control of the output, and normal use of the output point is inhibited. The output waveform is not affected by the state of the process-image register, the forced value of the point, or the execution of immediate output instructions. When the PTO/PWM generator is inactive, control of the output reverts to the process-image register. The process-image register determines the initial and final state of the output waveform, causing the waveform to start and end at a high or low level.

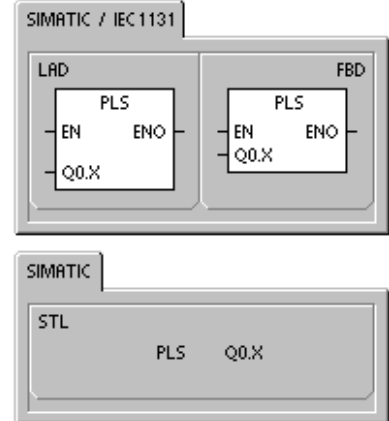

Table 6-30 Valid Operands for Pulse Output Instruction

Inputs/Outputs	Data Types	Operands
Q0.X	WORD	Constant: 0 (= Q0.0) or 1 (= Q0.1)



Tip

Before enabling PTO or PWM operation, set the value of the process-image register for Q0.0 and Q0.1 to 0.

Default values for all control bits, cycle time, pulse width, and pulse count values are 0.

The PTO/PWM outputs must have a minimum load of at least 10% of rated load to provide crisp transitions from off to on, and from on to off.



Tips and Tricks

Refer to the *Tips and Tricks* on the documentation CD for programs that use the PLS instruction for PTO/PWM operation. See *Tip 7*, *Tip 22*, *Tip 23*, *Tip 30*, and *Tip 50*.

Pulse Train Operation (PTO)

PTO provides a square wave (50% duty cycle) output for a specified number of pulses and a specified cycle time. (See Figure 6-28.) PTO can produce either a single train of pulses or multiple trains of pulses (using a pulse profile). You specify the number of pulses and the cycle time (in either microsecond or millisecond increments):

- Number of pulses: 1 to 4,294,967,295
- Cycle time: 50 μ s to 65,535 μ s or 2 ms to 65,535 ms.

Specifying an odd number of microseconds or milliseconds for the cycle time (such as 75 ms), causes some distortion in the duty cycle.

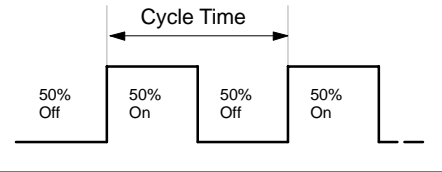

Figure 6-28 Pulse Train Output (PTO)

See Table 6-31 for pulse count and cycle time limitations.

Table 6-31 Pulse Count and Cycle Time in the PTO function

Pulse Count/Cycle Time	Reaction
Cycle time < 2 time units	Cycle time defaults to 2 time units.
Pulse count = 0	Pulse count defaults to 1 pulse.

The PTO function allows the “chaining” or “pipelining” of pulse trains. When the active pulse train is complete, the output of a new pulse train begins immediately. This allows continuity between subsequent output pulse trains.

Single-Segment Pipelining of PTO Pulses

In single-segment pipelining, you are responsible for updating the SM locations for the next pulse train. After the initial PTO segment has been started, you must modify immediately the SM locations as required for the second waveform and execute the PLS instruction again. The attributes of the second pulse train are held in a pipeline until the first pulse train is completed. Only one entry at a time can be stored in the pipeline. When the first pulse train completes, the output of the second waveform begins, and the pipeline is made available for a new pulse train specification. You can then repeat this process to set up the characteristics of the next pulse train.

Smooth transitions between pulse trains occur unless there is a change in the time base or the active pulse train completes before a new pulse train setup is captured by the execution of the PLS instruction.

Multiple-Segment Pipelining of PTO Pulses

In multiple-segment pipelining, the S7-200 automatically reads the characteristics of each pulse train segment from a profile table located in V memory. The SM locations used in this mode are the control byte, the status byte, and the starting V memory offset of the profile table (SMW168 or SMW178). The time base can be either microseconds or milliseconds, but the selection applies to all cycle time values in the profile table, and cannot be changed while the profile is running. Execution on the PLS instruction starts multiple segment operation.

Each segment entry is 8 bytes in length, and is composed of a 16-bit cycle time value, a 16-bit cycle time delta value, and a 32-bit pulse count value. Table 6-32 shows the format of the profile table. You can increase or decrease the cycle time automatically by programming a specified amount for each pulse. A positive value in the cycle time delta field increases cycle time, a negative value in the cycle time delta field decreases cycle time, and 0 results in an unchanging cycle time.

While the PTO profile is operating, the number of the currently active segment is available in SMB166 (or SMB176).

Table 6-32 Profile Table Format for Multiple-Segment PTO Operation

Byte Offset	Segment	Description of Table Entries
0		Number of segments: 1 to 255 ¹
1	#1	Initial cycle time (2 to 65,535 units of the time base)
3		Cycle time delta per pulse (signed value) (-32,768 to 32,767 units of the time base)
5		Pulse count (1 to 4,294,967,295)
9	#2	Initial cycle time (2 to 65,535 units of the time base)
11		Cycle time delta per pulse (signed value) (-32,768 to 32,767 units of the time base)
13		Pulse count (1 to 4,294,967,295)
(Continues)	#3	(Continues)

¹ Entering a value of 0 for the number of segments generates a non-fatal error. No PTO output is generated.

Pulse Width Modulation (PWM)

PWM provides a fixed cycle time output with a variable duty cycle. (See Figure 6-29.) You can specify the cycle time and the pulse width in either microsecond or millisecond increments:

- Cycle time: 50 μ s to 65,535 μ s or 2 ms to 65,535 ms
- Pulse width time: 0 μ s to 65,535 μ s or 0 ms to 65,535 ms

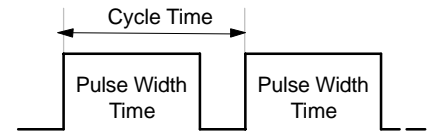

Figure 6-29 Pulse Width Modulation (PWM)

As shown in Table 6-33, setting the pulse width equal to the cycle time (which makes the duty cycle 100 percent) turns the output on continuously. Setting the pulse width to 0 (which makes the duty cycle 0 percent) turns the output off.

Table 6-33 Pulse Width Time and Cycle Time and Reactions in the PWM Function

Pulse Width Time/ Cycle Time	Reaction
Pulse width time \geq Cycle time value	The duty cycle is 100%: the output is turned on continuously.
Pulse width time = 0	The duty cycle is 0%: the output is turned off.
Cycle time < 2 time units	The cycle time defaults to two time units.

There are two different ways to change the characteristics of a PWM waveform:

- Synchronous Update: If no time base changes are required, you can use a synchronous update. With a synchronous update, the change in the waveform characteristics occurs on a cycle boundary, providing a smooth transition.
- Asynchronous Update: Typically with PWM operation, the pulse width is varied while the cycle time remains constant so time base changes are not required. However, if a change in the time base of the PTO/PWM generator is required, an asynchronous update is used. An asynchronous update causes the PTO/PWM generator to be disabled momentarily, asynchronous to the PWM waveform. This can cause undesirable jitter in the controlled device. For that reason, synchronous PWM updates are recommended. Choose a time base that you expect to work for all of your anticipated cycle time values.

**Tip**

The PWM Update Method bit (SM67.4 or SM77.4) in the control byte specifies the update type used when the PLS instruction is executed to invoke changes.

If the time base is changed, an asynchronous update occurs regardless of the state of the PWM Update Method bit.

Using SM Locations to Configure and Control the PTO/PWM Operation

The PLS instruction reads the data stored in the specified SM memory locations and programs the PTO/PWM generator accordingly. SMB67 controls PTO 0 or PWM 0, and SMB77 controls PTO 1 or PWM 1. Table 6-34 describes the registers used to control the PTO/PWM operation. You can use Table 6-35 as a quick reference to determine the value to place in the PTO/PWM control register to invoke the desired operation.

You can change the characteristics of a PTO or PWM waveform by modifying the locations in the SM area (including the control byte) and then executing the PLS instruction. You can disable the generation of a PTO or PWM waveform at any time by writing 0 to the PTO/PWM enable bit of the control byte (SM67.7 or SM77.7) and then executing the PLS instruction.

The PTO Idle bit in the status byte (SM66.7 or SM76.7) is provided to indicate the completion of the programmed pulse train. In addition, an interrupt routine can be invoked upon the completion of a pulse train. (Refer to the descriptions of the Interrupt instructions and the Communications instructions.) If you are using the multiple segment operation, the interrupt routine is invoked upon completion of the profile table.

The following conditions set SM66.4 (or SM76.4) and SM66.5 (or SM76.5):

- Specifying a cycle time delta value that results in an illegal cycle time after a number of pulses generates a mathematical overflow condition that terminates the PTO function and sets the Delta Calculation Error bit (SM66.4 or SM76.4) to 1. The output reverts to image register control.
- Manually aborting (disabling) a PTO profile in progress sets the User Abort bit (SM66.5 or SM76.5) to 1.
- Attempting to load the pipeline while it is full sets the PTO overflow bit (SM66.6 or SM76.6) to 1. You must clear this bit manually after an overflow is detected if you want to detect subsequent overflows. The transition to RUN mode initializes this bit to 0.

**Tip**

When you load a new pulse count (SMD72 or SMD82), pulse width (SMW70 or SMW80), or cycle time (SMW68 or SMW78), also set the appropriate update bits in the control register before you execute the PLS instruction. For a multiple segment pulse train operation, you must also load the starting offset (SMW168 or SMW178) of the profile table and the profile table values before you execute the PLS instruction.

Table 6-34 SM Locations of the PTO / PWM Control Registers

Q0.0	Q0.1	Status Bits		
SM66.4	SM76.4	PTO profile aborted (delta calculation error):	0 = no error	1 = aborted
SM66.5	SM76.5	PTO profile aborted due to user command:	0 = no abort	1 = aborted
SM66.6	SM76.6	PTO pipeline overflow/underflow:	0 = no overflow	1 = overflow/underflow
SM66.7	SM76.7	PTO idle:	0 = in progress	1 = PTO idle
Q0.0	Q0.1	Control Bits		
SM67.0	SM77.0	PTO/PWM update the cycle time:	0 = no update	1 = update cycle time
SM67.1	SM77.1	PWM update the pulse width time:	0 = no update	1 = update pulse width
SM67.2	SM77.2	PTO update the pulse count value:	0 = no update	1 = update pulse count
SM67.3	SM77.3	PTO/PWM time base:	0 = 1 μ s/tick	1 = 1 ms/tick
SM67.4	SM77.4	PWM update method:	0 = asynchronous	1 = synchronous
SM67.5	SM77.5	PTO single/multiple segment operation:	0 = single	1 = multiple
SM67.6	SM77.6	PTO/PWM mode select:	0 = PTO	1 = PWM
SM67.7	SM77.7	PTO/PWM enable:	0 = disable	1 = enable
Q0.0	Q0.1	Other PTO/PWM Registers		
SMW68	SMW78	PTO/PWM cycle time value	range: 2 to 65,535	
SMW70	SMW80	PWM pulse width value	range: 0 to 65,535	
SMD72	SMD82	PTO pulse count value	range: 1 to 4,294,967,295	
SMB166	SMB176	Number of the segment in progress	Multiple-segment PTO operation only	
SMW168	SMW178	Starting location of the profile table (byte offset from V0)	Multiple-segment PTO operation only	

Table 6-35 PTO/PWM Control Byte Reference

Control Register (Hex Value)	Result of Executing the PLS Instruction							
	Enable	Select Mode	PTO Segment Operation	PWM Update Method	Time Base	Pulse Count	Pulse Width	Cycle Time
16#81	Yes	PTO	Single		1 μ s/cycle			Load
16#84	Yes	PTO	Single		1 μ s/cycle	Load		
16#85	Yes	PTO	Single		1 μ s/cycle	Load		Load
16#89	Yes	PTO	Single		1 ms/cycle			Load
16#8C	Yes	PTO	Single		1 ms/cycle	Load		
16#8D	Yes	PTO	Single		1 ms/cycle	Load		Load
16#A0	Yes	PTO	Multiple		1 μ s/cycle			
16#A8	Yes	PTO	Multiple		1 ms/cycle			
16#D1	Yes	PWM		Synchronous	1 μ s/cycle			Load
16#D2	Yes	PWM		Synchronous	1 μ s/cycle		Load	
16#D3	Yes	PWM		Synchronous	1 μ s/cycle		Load	Load
16#D9	Yes	PWM		Synchronous	1 ms/cycle			Load
16#DA	Yes	PWM		Synchronous	1 ms/cycle		Load	
16#DB	Yes	PWM		Synchronous	1 ms/cycle		Load	Load

Calculating Profile Table Values

The multiple-segment pipelining capability of the PTO/PWM generators can be useful in many applications, particularly in stepper motor control.

For example, you can use PTO with a pulse profile to control a stepper motor through a simple ramp up, run, and ramp down sequence or more complicated sequences by defining a pulse profile that consists of up to 255 segments, with each segment corresponding to a ramp up, run, or ramp down operation.

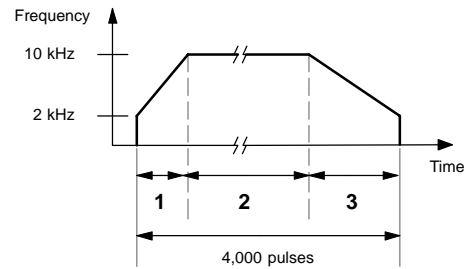

Figure 6-30 illustrates sample profile table values required to generate an output waveform that accelerates a stepper motor (segment 1), operates the motor at a constant speed (segment 2), and then decelerates the motor (segment 3).

1 Segment #1 200 pulses 2 Segment #2 3400 pulses 3 Segment #3 400 pulses

Figure 6-30 Frequency/Time Diagram

For this example: The starting and final pulse frequency is 2 kHz, the maximum pulse frequency is 10 kHz, and 4000 pulses are required to achieve the desired number of motor revolutions. Since the values for the profile table are expressed in terms of period (cycle time) instead of frequency, you must convert the given frequency values into cycle time values. Therefore, the starting (initial) and final (ending) cycle time is 500 μs, and the cycle time corresponding to the maximum frequency is 100 μs. During the acceleration portion of the output profile, the maximum pulse frequency should be reached in approximately 200 pulses. The deceleration portion of the profile should be completed in approximately 400 pulses.

You can use the following formula to determine the delta cycle time value for a given segment that the PTO/PWM generator uses to adjust the cycle time of each pulse:

$$\text{Delta cycle time for a segment} = | \text{End_CT}_{\text{seg}} - \text{Init_CT}_{\text{seg}} | / \text{Quantity}_{\text{seg}}$$

where: End_CT_{seg} = Ending cycle time for this segment
 Init_CT_{seg} = Initial cycle time for this segment
 Quantity_{seg} = Quantity of pulses in this segment

Using this formula to calculate the delta cycle time values for the sample application:

Segment 1 (acceleration):
 Delta cycle time = -2

Segment 2 (constant speed):
 Delta cycle time = 0

Segment 3 (deceleration):
 Delta cycle time = 1

Table 6-36 lists the values for generating the example waveform (assumes that the profile table is located in V memory, starting at V500). You can include instructions in your program to load these values into V memory, or you can define the values of the profile in the data block.

Table 6-36 Profile Table Values

Address	Value	Description	
VB500	3	Total number of segments	
VW501	500	Initial cycle time	Segment 1
VW503	-2	Initial delta cycle time	
VD505	200	Number of pulses	
VW509	100	Initial cycle time	Segment 2
VW511	0	Delta cycle time	
VD513	3400	Number of pulses	
VW517	100	Initial cycle time	Segment 3
VW519	1	Delta cycle time	
VD521	400	Number of pulses	

In order to determine if the transitions between waveform segments are acceptable, you need to determine the cycle time of the last pulse in a segment. Unless the delta cycle time is 0, you must calculate the cycle time of the last pulse of a segment, because this value is not specified in the profile. Use the following formula to calculate the cycle time of the last pulse:

$$\text{Cycle time of the last pulse for a segment} = \text{Init_CT}_{\text{seg}} + (\text{Delta}_{\text{seg}} * (\text{Quantity}_{\text{seg}} - 1))$$

where: $\text{Init_CT}_{\text{seg}}$ = Initial cycle time for this segment

$\text{Delta}_{\text{seg}}$ = Delta cycle time for this segment

$\text{Quantity}_{\text{seg}}$ = Quantity of pulses in this segment

While the simplified example above is useful as an introduction, real applications can require more complicated waveform profiles. Remember that the delta cycle time can be specified only as an integer number of microseconds or milliseconds, and the cycle time modification is performed on each pulse.

The effect of these two items is that calculation of the delta cycle time value for a given segment could require an iterative approach. Some flexibility in the value of the ending cycle time or the number of pulses for a given segment might be required.

The duration of a given profile segment can be useful in the process of determining correct profile table values. Use the following formula to calculate the length of time for completing a given profile segment:

$$\text{Duration of segment} = \text{Quantity}_{\text{seg}} * (\text{Init_CT} + ((\text{Delta}_{\text{seg}}/2) * (\text{Quantity}_{\text{seg}} - 1)))$$

where: $\text{Quantity}_{\text{seg}}$ = Quantity of pulses in this segment

$\text{Init_CT}_{\text{seg}}$ = Initial cycle time for this segment

$\text{Delta}_{\text{seg}}$ = Delta cycle time for this segment

Sample Operation of a PWM Output



Tip

The following description of the PWM initialization and operation sequences recommends using the First Scan bit (SM0.1) to initialize the pulse output. Using the First Scan bit to call an initialization subroutine reduces the scan time because subsequent scans do not call this subroutine. (The First Scan bit is set only on the first scan following a transition to RUN mode.) However, your application could have other constraints that require you to initialize (or re-initialize) the pulse output. In that case, you can use another condition to call the initialization routine.

Initializing the PWM Output

Typically, you use a subroutine to initialize the PWM for the pulse output. You call the initialization subroutine from the main program. Use the first scan memory bit (SM0.1) to initialize the output used by the PWM to 0, and call a subroutine to perform the initialization operations. When you use the subroutine call, subsequent scans do not make the call to the subroutine, which reduces the scan time execution and provides a more structured program.

After creating the call to the initialization subroutine from the main program, use the following steps to create the control logic for configuring pulse output Q0.0 within the initialization subroutine:

1. Configure the control byte by loading one of the following values to SMB67: 16#D3 (to select microsecond increments) or 16#DB (to select millisecond increments).
Both of these values enable the PTO/PWM function, select PWM operation, set the update pulse width and cycle time values, and select the time base (microseconds or milliseconds).
2. Load a word-sized value for the cycle time in SMW68.
3. Load a word-sized value for the pulse width in SMW70.
4. Execute the PLS instruction (so that the S7-200 programs the PTO/PWM generator).
5. To preload a new control byte value for subsequent pulse width changes (optional), load one of the following values in SMB67: 16#D2 (microseconds) or 16#DA (milliseconds).
6. Exit the subroutine.

Changing the Pulse Width for the PWM Output

If you preloaded SMB67 with 16#D2 or 16#DA (see step 5. above), you can use a subroutine that changes the pulse width for the pulse output (Q0.0). After creating the call to this subroutine, use the following steps to create the control logic for changing the pulse width:

1. Load a word-sized value for the new pulse width in SMW70.
2. Execute the PLS instruction (so that the S7-200 programs the PTO/PWM generator).
3. Exit the subroutine.

Example: Pulse Width Modulation (PWM)

<p>M A I N</p>	<p>Network 1 //On the first scan, //set the image register bit low and call SBR_0.</p> <pre>LD SM0.1 R Q0.1, 1 CALL SBR_0</pre> <p>Network 2 //Set M0.0 elsewhere in the program //to change pulse width to 50% duty cycle.</p> <pre>LD M0.0 EU CALL SBR_1</pre>
-----------------------------------	--

<p>S B R 0</p>	<p>Network 1 //Start of subroutine 0: //1. Set up the control byte. // - Select PWM operation. // - Select ms increments and // synchronous updates. // - Enable the loading of the pulse width // and cycle time values. // - Enable the PWM function. //2. Set the cycle time to 10,000 ms. //3. Set pulse width to 1,000 ms. //4. Invoke PWM operation: PLS1=>Q0.1. //5. Preload the control byte for subsequent // pulse width changes</p> <pre>LD SM0.0 MOVB 16#DB, SMB77 MOVW +10000, SMW78 MOVW +1000, SMW80 PLS 1 MOVB 16#DA, SMB77</pre>
-----------------------------------	--

<p>S B R 1</p>	<p>Network 1 //Start of subroutine 1: //Set the pulse width to 5000 ms. //Assert pulse width change.</p> <pre>LD SM0.0 MOVW +5000, SMW80 PLS 1</pre>
-----------------------------------	--

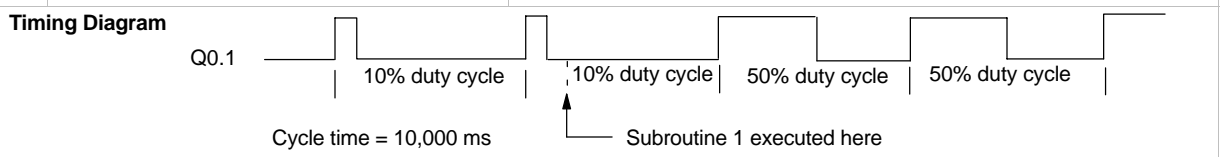

Sample Operation of a PTO Output



Tip

The following description of the PTO initialization and operation sequences recommends using the First Scan memory bit (SM0.1) to initialize the pulse output. Using the First Scan bit to call an initialization subroutine reduces the scan time because subsequent scans do not call this subroutine. (The First Scan bit is set only on the first scan following a transition to RUN mode.) However, your application could have other constraints that require you to initialize (or re-initialize) the pulse output. In that case, you can use another condition to call the initialization routine.

Initializing the PTO Output for a Single-Segment Operation

Typically, you use a subroutine to configure and initialize the PTO for the pulse output. You call the initialization subroutine from the main program. Use the first scan memory bit (SM0.1) to initialize the output used by the PTO to 0, and call a subroutine to perform the initialization operations. When you use the subroutine call, subsequent scans do not make the call to the subroutine, which reduces the scan time execution and provides a more structured program.

After creating the call to the initialization subroutine from the main program, use the following steps to create the control logic for configuring pulse output Q0.0 within the initialization subroutine:

1. Configure the control byte by loading one of the following values in SMB67: 16#85 (to select microsecond increments) or 16#8D (to select millisecond increments).
Both of these values enable the PTO/PWM function, select PTO operation, set the update pulse count and cycle time values, and select the time base (microseconds or milliseconds).
2. In SMW68, load a word-sized value for the cycle time.
3. In SMD72, load a double-word-sized value for the pulse count.
4. (Optional) To perform a related function as soon as the pulse train output is complete, you can program an interrupt by attaching the pulse train complete event (interrupt event 19) to an interrupt subroutine. Use the ATCH instruction and execute the global interrupt enable instruction ENI.
5. Execute the PLS instruction (so that the S7-200 programs the PTO/PWM generator).
6. Exit the subroutine.

Changing the PTO Cycle Time (Single-Segment Operation)

For a single-segment PTO operation, you can use an interrupt routine or a subroutine to change the cycle time. To change the PTO cycle time in an interrupt routine or subroutine when using a single-segment PTO operation, follow these steps:

1. Set the control byte (to enable the PTO/PWM function, to select PTO operation, to select the time base, and to set the update cycle time value) by loading one of the following values in SMB67: 16#81 (for microseconds) or 16#89 (for milliseconds).
2. In SMW68, load a word-sized value for the new cycle time.
3. Execute the PLS instruction (so that the S7-200 programs the PTO/PWM generator). The S7-200 completes any PTO that is in process before starting to generate the PTO waveform with the updated cycle time.
4. Exit the interrupt routine or the subroutine.

Changing the PTO Pulse Count (Single-Segment Operation)

For a single-segment PTO operation, you can use an interrupt routine or a subroutine to change the pulse count. To change the PTO pulse count in an interrupt routine or a subroutine when using a single-segment PTO operation, follow these steps:

1. Set the control byte (to enable the PTO/PWM function, to select PTO operation, to select the time base, and to set the update pulse count value) by loading either of the following values in SMB67: 16#84 (for microseconds) or 16#8C (for milliseconds).
2. In SMD72, load a double-word-sized value for the new pulse count.
3. Execute the PLS instruction (so that the S7-200 programs the PTO/PWM generator). The S7-200 completes any PTO that is in process before starting to generate the waveform with the updated pulse count.
4. Exit the interrupt routine or the subroutine.

Changing the PTO Cycle Time and the Pulse Count (Single-Segment Operation)

For a single-segment PTO operation, you can use an interrupt routine or a subroutine to change the cycle time and pulse count. To change the PTO cycle time and pulse count in an interrupt routine or a subroutine when using a single-segment PTO operation, follow these steps:

1. Set the control byte (to enable the PTO/PWM function, to select PTO operation, to select the time base, and to set the update cycle time and pulse count values) by loading either of the following values in SMB67: 16#85 (for microseconds) or 16#8D (for milliseconds).
2. In SMW68, load a word-sized value for the new cycle time.
3. In SMC72, load a double-word-sized value for the new pulse count.
4. Execute the PLS instruction (so that the S7-200 programs the PTO/PWM generator). The S7-200 completes any PTO that is in process before starting to generate the waveform with the updated pulse count and cycle time.
5. Exit the interrupt routine or the subroutine.

Initializing the PTO Output for a Multiple-Segment Operation

Typically, you use a subroutine to configure and initialize the PTO for the pulse output for multiple-segment operation. You call the initialization subroutine from the main program. Use the first scan memory bit (SM0.1) to initialize the output used by the PTO to 0, and call a subroutine to perform the initialization operations. When you use the First Scan bit to call the initialization subroutine, the subsequent scans do not make the call to the subroutine, which reduces scan time execution.

After creating the call to the initialization subroutine from the main program, use the following steps to create the control logic for configuring pulse output Q0.0 within the initialization subroutine:

1. Configure the control byte by loading one of the following values in SMB67: 16#A0 (to select microsecond increments) or 16#A8 (to select millisecond increments).
Both of these values enable the PTO/PWM function, select PTO operation, select multiple-segment operation, and select the time base (microseconds or milliseconds).
2. In SMW168, load a word-sized value for the starting V memory offset of the profile table.
3. Use V memory to set up the segment values in the profile table. Ensure that the Number of Segment field (the first byte of the table) is correct.
4. (Optional) To perform a related function as soon as the PTO profile is complete, you can program an interrupt by attaching the pulse train complete event (interrupt event 19) to an interrupt subroutine. Use the ATCH instruction and execute the global interrupt enable instruction ENI.
5. Execute the PLS instruction (so that the S7-200 programs the PTO/PWM generator).
6. Exit the subroutine.

Example: Single-Segment Pulse Train Operation (PTO)

M A I N	<p>Network 1</p>	<p>Network 1 //On the first scan, //set the image register bit low and call subroutine 0.</p> <pre>LD SM0.1 R Q0.0, 1 CALL SBR_0</pre>
S B R 0	<p>Network 1</p>	<p>Network 1 //Start of subroutine 0: Configure PTO</p> <p>//1. Set up the control byte: // - Select PTO operation. // - Select single segment operation. // - Select ms increments. // - Enable the loading of the pulse count // and cycle time value. // - Enable the PTO function.</p> <p>//2. Set cycle time to 500ms. //3. Set pulse count to 4 pulses. //4. Define interrupt routine 0 to be the interrupt // for processing PTO complete interrupts. //5. Global interrupt enable. //6. Invoke PTO operation, PLS0 => Q0.0. //7. Preload the control byte for subsequent cycle time //changes.</p> <pre>LD SM0.0 MOVB 16#8D, SMB67 MOVW +500, SMW68 MOVD +4, SMD72 ATCH INT_0, 19 ENI PLS 0 MOVB 16#89, SMB67</pre>

6

Example: Single-Segment Pulse Train Operation (PTO), continued

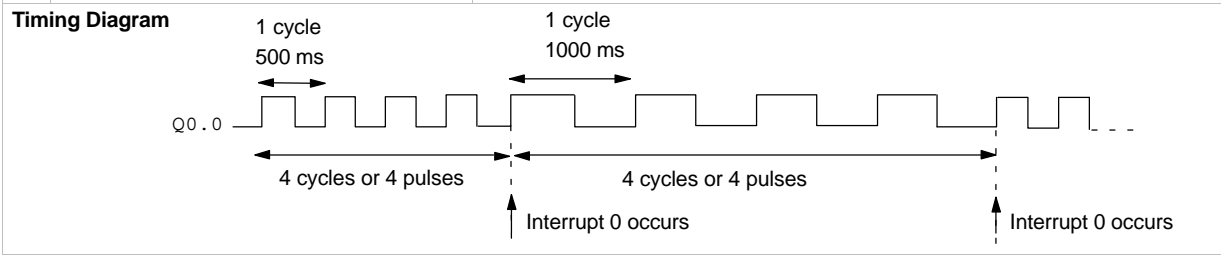
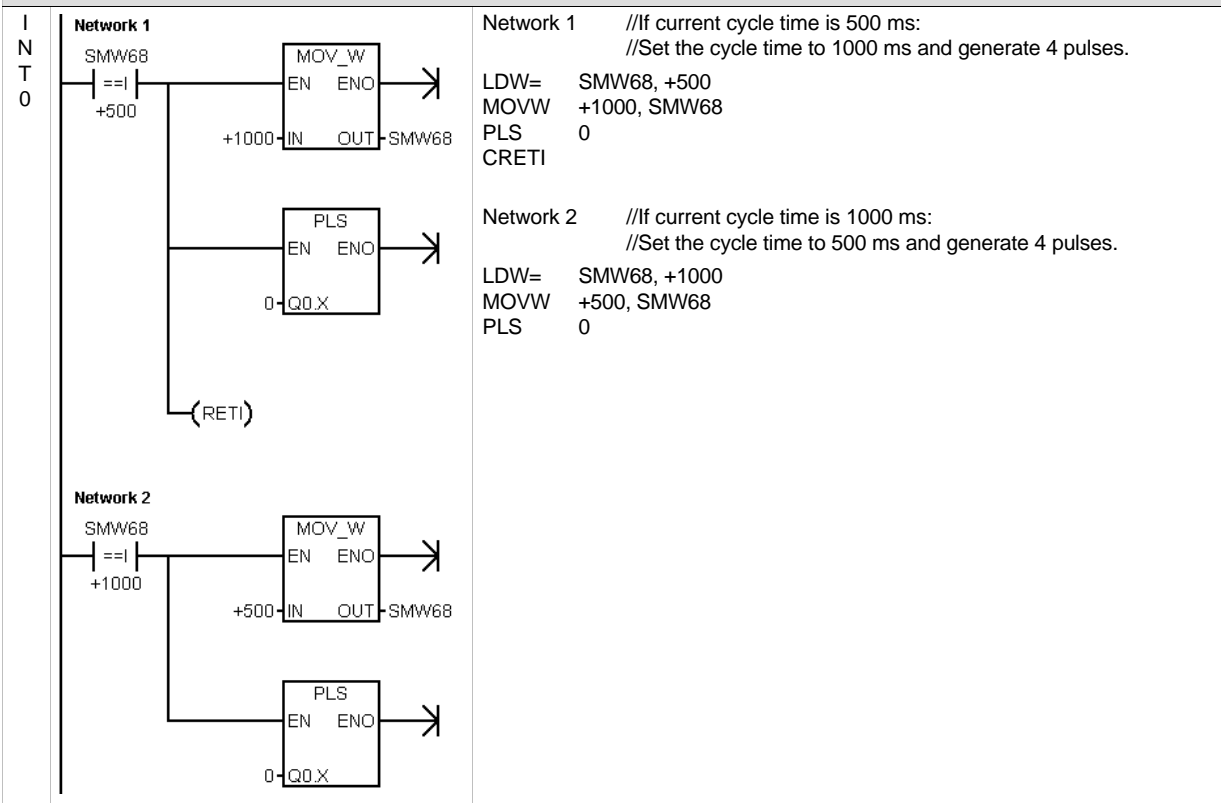

Example: Multiple-Segment Pulse Train Operation (PTO)

M A I N	<p>Network 1</p>	<p>Network 1 //On the first scan, //set the image register bit low and call subroutine 0</p> <pre>LD SM0.1 R Q0.0, 1 CALL SBR_0</pre>
S B R 0	<p>Network 1</p>	<p>Network 1 //Preload the PTO profile table: //Set number of profile table segments to 3. //Configure each of the 3 segments. // //1. Configure segment 1: // - Set the initial cycle time = 500 ms. // - Set the delta cycle time to -2 ms. // - Set the number of pulses to 200. //2. Configure segment 2: // - Set the initial cycle time to 100 ms. // - Set the delta cycle time to 0 ms. // - Set the number of pulses to 3400. //3. Configure segment 3: // - Set the initial cycle time to 100 ms. // - Set the delta cycle time to 1 ms. // - Set the number of pulses to 400.</p> <pre>LD SM0.0 MOVB 3, VB500 MOVW +500, VW501 //Segment 1 MOVW -2, VW503 MOVD +200, VD505 MOVW +100, VW509 //Segment 2 MOVW +0, VW511 MOVD +3400, VD513 MOVW +100, VW517 //Segment 3 MOVW +1, VW519 MOVD +400, VD521</pre>

6

Example: Multiple-Segment Pulse Train Operation (PTO) , continued

<p>S B R O c o n t i n u e d</p>		<p>Network 2 //1. Set up the control byte: // - Select PTO operation // - Select multiple segment operation // - Select ms increments // - Enable the PTO function //2. Set the start address of the profile table to V500. //3. Define interrupt routine 0 to be the interrupt // for processing PTO complete interrupts. //4. Global interrupt enable //5. Invoke PTO operation, PLS0 => Q0.0.</p> <pre>LD SM0.0 MOVB 16#A8, SMB67 MOVW +500, SMW168 ATCH INT_0, 19 ENI PLS 0</pre>
<p>I N T O</p>	<p>Network 1</p>	<p>Network 1 //When the PTO output profile is complete, //Turn on output Q0.5</p> <pre>LD SM0.0 = Q0.5</pre>

Math Instructions

Add, Subtract, Multiply, and Divide Instructions

Add

IN1 + IN2 = OUT
IN1 + OUT = OUT

Subtract

IN1 – IN2 = OUT *LAD and FBD*
OUT – IN1 = OUT *STL*

The Add Integer (+I) or Subtract Integer (–I) instructions add or subtract two 16-bit integers to produce a 16-bit result. The Add Double Integer (+D) or Subtract Double Integer (–D) instructions add or subtract two 32-bit integers to produce a 32-bit result. The Add Real (+R) and Subtract Real (–R) instructions add or subtract two 32-bit real numbers to produce a 32-bit real number result.

Multiply

IN1 * IN2 = OUT
IN1 * OUT = OUT

Divide

IN1 / IN2 = OUT *LAD and FBD*
OUT / IN1 = OUT *STL*

The Multiply Integer (*I) or Divide Integer (/I) instructions multiply or divide two 16-bit integers to produce a 16-bit result. (For division, no remainder is kept.) The Multiply Double Integer (*D) or Divide Double Integer (/D) instructions multiply or divide two 32-bit integers to produce a 32-bit result. (For division, no remainder is kept.) The Multiply Real (*R) or Divide Real (/R) instructions multiply or divide two 32-bit real numbers to produce a 32-bit real number result.

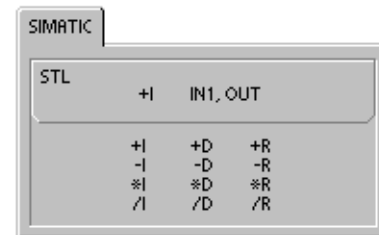
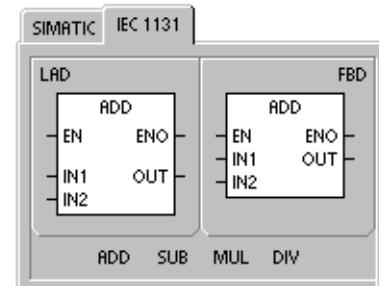
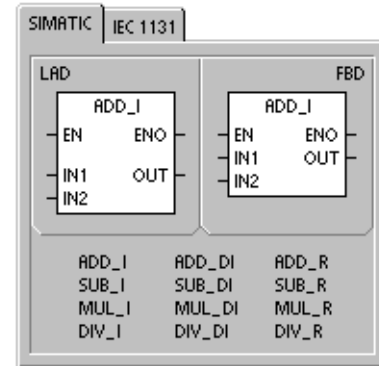

SM Bits and ENO

SM1.1 indicates overflow errors and illegal values. If SM1.1 is set, then the status of SM1.0 and SM1.2 is not valid and the original input operands are not altered. If SM1.1 and SM1.3 are not set, then the math operation has completed with a valid result and SM1.0 and SM1.2 contain valid status. If SM1.3 is set during a divide operation, then the other math status bits are left unchanged.

Error conditions that set ENO = 0

- SM1.1 (overflow)
- SM1.3 (divide by zero)
- 0006 (indirect address)

Special Memory bits affected

- SM1.0 (zero)
- SM1.1 (overflow, illegal value generated during the operation, or illegal input parameter found)
- SM1.2 (negative)
- SM1.3 (divide by zero)

Table 6-37 Valid Operands for Add, Subtract, Multiply, and Divide Instructions

Inputs/Outputs	Data Types	Operands
IN1, IN2	INT DINT REAL	IW, QW, VW, MW, SMW, SW, T, C, LW, AC, AIW, *VD, *AC, *LD, Constant ID, QD, VD, MD, SMD, SD, LD, AC, HC, *VD, *LD, *AC, Constant ID, QD, VD, MD, SMD, SD, LD, AC, *VD, *LD, *AC, Constant
OUT	INT DINT, REAL	IW, QW, VW, MW, SMW, SW, LW, T, C, AC, *VD, *AC, *LD ID, QD, VD, MD, SMD, SD, LD, AC, *VD, *LD, *AC

Real (or floating-point) numbers are represented in the format described in the ANSI/IEEE 754–1985 standard (single-precision). Refer to that standard for more information.

Example: Integer Math Instructions

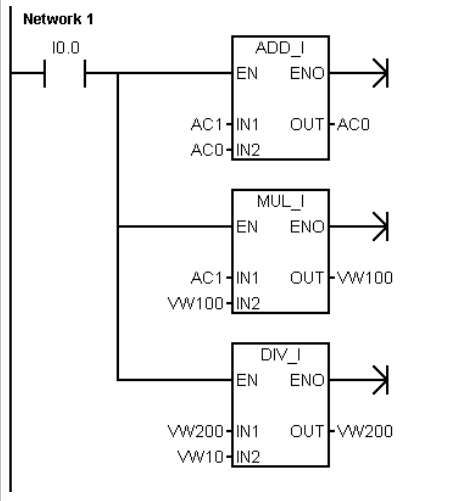

```

Network 1
LD   I0.0
+I   AC1, AC0
*I   AC1, VW100
/I   VW10, VW200
    
```

Add

$$\boxed{40} + \boxed{60} = \boxed{100}$$

AC1 AC0 AC0

Multiply

$$\boxed{40} * \boxed{20} = \boxed{800}$$

AC1 VW100 VW100

Divide

$$\boxed{4000} / \boxed{40} = \boxed{100}$$

VW200 VW10 VW200

Example: Real Math Instructions

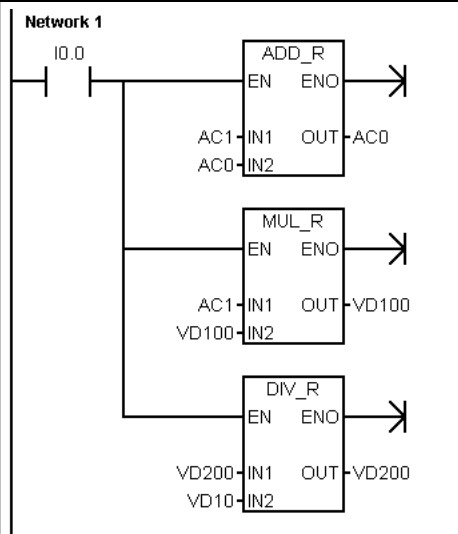

```

Network 1
LD   I0.0
+R   AC1, AC0
*R   AC1, VD100
/R   VD10, VD200
    
```

Add

$$\boxed{4000.0} + \boxed{6000.0} = \boxed{10000.0}$$

AC1 AC0 AC0

Multiply

$$\boxed{400.0} * \boxed{200.0} = \boxed{80000.0}$$

AC1 VD100 VD100

Divide

$$\boxed{4000.0} / \boxed{41.0} = \boxed{97.5609}$$

VD200 VD10 VD200

Multiply Integer to Double Integer and Divide Integer with Remainder

Multiply Integer to Double Integer

IN1 * IN2 = OUT LAD and FBD
 IN1 * OUT = OUT STL

The Multiply Integer to Double Integer instruction (MUL) multiplies two 16-bit integers and produces a 32-bit product. In the STL MUL instruction, the least-significant word (16 bits) of the 32-bit OUT is used as one of the factors.

Divide Integer with Remainder

IN1 / IN2 = OUT LAD and FBD
 OUT / IN1 = OUT STL

The Divide Integer with Remainder instruction (DIV) divides two 16-bit integers and produces a 32-bit result consisting of a 16-bit remainder (the most-significant word) and a 16-bit quotient (the least-significant word).

In STL, the least-significant word (16 bits) of the 32-bit OUT is used as the dividend.

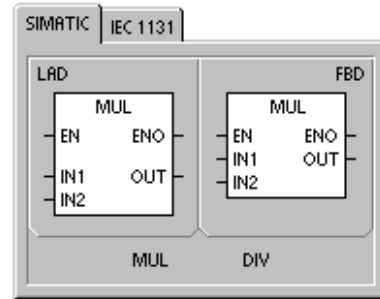

6

SM Bits and ENO

For both of the instructions on this page, Special Memory (SM) bits indicate errors and illegal values. If SM1.3 (divide by zero) is set during a divide operation, then the other math status bits are left unchanged. Otherwise, all supported math status bits contain valid status upon completion of the math operation.

Error conditions that set ENO = 0

- SM1.1 (overflow)
- SM1.3 (divide by zero)
- 0006 (indirect address)

Special Memory bits affected

- SM1.0 (zero)
- SM1.1 (overflow)
- SM1.2 (negative)
- SM1.3 (divide by zero)

Table 6-38 Valid Operands for Multiply Integer to Double Integer and Divide Integer with Remainder

Inputs/Outputs	Data Types	Operands
IN1, IN2	INT	IW, QW, VW, MW, SMW, SW, T, C, LW, AC, AIW, *VD, *LD, *AC, Constant
OUT	DINT	ID, QD, VD, MD, SMD, SD, LD, AC, *VD, *LD, *AC

Example: Multiply Integer to Double Integer Instruction and Divide Integer with Remainder Instruction

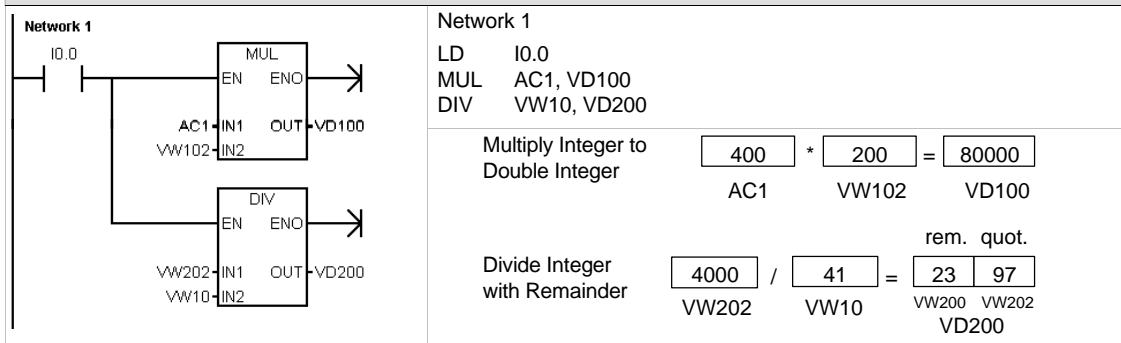

Note: VD100 contains: VW100 and VW102, and VD200 contains: VW200 and VW202.

Numeric Functions Instructions

Sine, Cosine, and Tangent

The Sine (SIN), Cosine (COS), and Tangent (TAN) instructions evaluate the trigonometric function of the angle value IN and place the result in OUT. The input angle value is in radians.

SIN (IN) = OUT COS (IN) = OUT TAN (IN) = OUT

To convert an angle from degrees to radians: Use the MUL_R (*R) instruction to multiply the angle in degrees by 1.745329E-2 (approximately by $\pi/180$).

Natural Logarithm and Natural Exponential

The Natural Logarithm instruction (LN) performs the natural logarithm of the value in IN and places the result in OUT.

The Natural Exponential instruction (EXP) performs the exponential operation of e raised to the power of the value in IN and places the result in OUT.

LN (IN) = OUT EXP (IN) = OUT

To obtain the base 10 logarithm from the natural logarithm: Divide the natural logarithm by 2.302585 (approximately the natural logarithm of 10).

To raise any real number to the power of another real number, including fractional exponents: Combine the Natural Exponential instruction with the Natural Logarithm instruction. For example, to raise X to the Y power, enter the following instruction: EXP (Y * LN (X)).

Square Root

The Square Root instruction (SQRT) takes the square root of a real number (IN) and produces a real number result OUT.

SQRT (IN) = OUT

To obtain other roots: 5 cubed = $5^3 = \text{EXP}(3 * \text{LN}(5)) = 125$
 The cube root of 125 = $125^{1/3} = \text{EXP}((1/3) * \text{LN}(125)) = 5$
 The square root of 5 cubed = $5^{3/2} = \text{EXP}(3/2 * \text{LN}(5)) = 11.18034$

SM Bits and ENO for the Numeric Functions Instructions

For all of the instructions that are described on this page, SM1.1 is used to indicate overflow errors and illegal values. If SM1.1 is set, then the status of SM1.0 and SM1.2 is not valid and the original input operands are not altered. If SM1.1 is not set, then the math operation has completed with a valid result and SM1.0 and SM1.2 contain valid status.

Error conditions that set ENO = 0 Special Memory bits affected

- SM1.1 (overflow)
- 0006 (indirect address)
- SM1.0 (zero)
- SM1.1 (overflow)
- SM1.2 (negative)

Table 6-39 Valid Operands for Numeric Functions

Inputs/Outputs	Data Types	Operands
IN	REAL	ID, QD, VD, MD, SMD, SD, LD, AC, *VD, *LD, *AC, Constant
OUT	REAL	ID, QD, VD, MD, SMD, SD, LD, AC, *VD, *LD, *AC

Real (or floating-point) numbers are represented in the format described in the ANSI/IEEE 754-1985 standard (single-precision). Refer to that standard for more information.

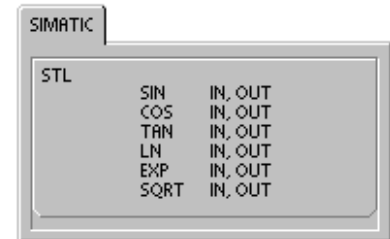
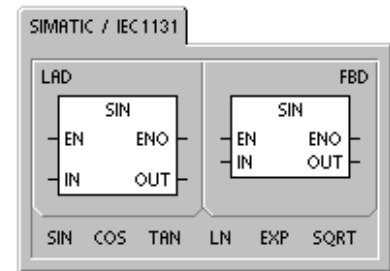

Proportional/Integral/Derivative (PID) Loop Instruction

The PID Loop instruction (PID) executes a PID loop calculation on the referenced LOOP based on the input and configuration information in Table (TBL).

Error conditions that set ENO = 0:

- SM1.1 (overflow)
- 0006 (indirect address)

Special Memory bits affected:

- SM1.1 (overflow)

The PID loop instruction (Proportional, Integral, Derivative Loop) is provided to perform the PID calculation. The top of the logic stack (TOS) must be ON (power flow) to enable the PID calculation. The instruction has two operands: a TABLE address which is the starting address of the loop table and a LOOP number which is a constant from 0 to 7.

Eight PID instructions can be used in a program. If two or more PID instructions are used with the same loop number (even if they have different table addresses), the PID calculations will interfere with one another and the output will be unpredictable.

The loop table stores nine parameters used for controlling and monitoring the loop operation and includes the current and previous value of the process variable, the setpoint, output, gain, sample time, integral time (reset), derivative time (rate), and the integral sum (bias).

To perform the PID calculation at the desired sample rate, the PID instruction must be executed either from within a timed interrupt routine or from within the main program at a rate controlled by a timer. The sample time must be supplied as an input to the PID instruction via the loop table.

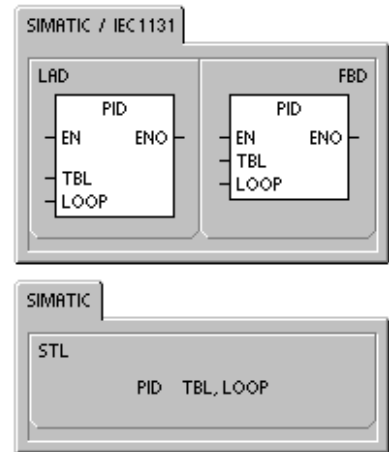

6

Table 6-41 Valid Operands for the PID Loop Instruction

Inputs/Outputs	Data Types	Operands
TBL	BYTE	VB
LOOP	BYTE	Constant (0 to 7)



Instruction
Wizard

STEP 7-Micro/WIN offers the PID Wizard to guide you in defining a PID algorithm for a closed-loop control process. Select the **Tools > Instruction Wizard** menu command and then select **PID** from the Instruction Wizard window.

Understanding the PID Algorithm

In steady state operation, a PID controller regulates the value of the output so as to drive the error (e) to zero. A measure of the error is given by the difference between the setpoint (SP) (the desired operating point) and the process variable (PV) (the actual operating point). The principle of PID control is based upon the following equation that expresses the output, $M(t)$, as a function of a proportional term, an integral term, and a differential term:

Output	=	Proportional term	+	Integral term	+	Differential term
$M(t)$	=	$K_C * e$	+	$K_C \int_0^t e dt + M_{initial}$	+	$K_C * de/dt$
where:	$M(t)$	is the loop output as a function of time				
	K_C	is the loop gain				
	e	is the loop error (the difference between setpoint and process variable)				
	$M_{initial}$	is the initial value of the loop output				

6

In order to implement this control function in a digital computer, the continuous function must be quantized into periodic samples of the error value with subsequent calculation of the output. The corresponding equation that is the basis for the digital computer solution is:

M_n	=	$K_C * e_n$	+	$K_I * \sum_1^n + M_{initial}$	+	$K_D * (e_n - e_{n-1})$
output	=	proportional term	+	integral term	+	differential term
where:	M_n	is the calculated value of the loop output at sample time n				
	K_C	is the loop gain				
	e_n	is the value of the loop error at sample time n				
	e_{n-1}	is the previous value of the loop error (at sample time $n - 1$)				
	K_I	is the proportional constant of the integral term				
	$M_{initial}$	is the initial value of the loop output				
	K_D	is the proportional constant of the differential term				

From this equation, the integral term is shown to be a function of all the error terms from the first sample to the current sample. The differential term is a function of the current sample and the previous sample, while the proportional term is only a function of the current sample. In a digital computer, it is not practical to store all samples of the error term, nor is it necessary.

Since the digital computer must calculate the output value each time the error is sampled beginning with the first sample, it is only necessary to store the previous value of the error and the previous value of the integral term. As a result of the repetitive nature of the digital computer solution, a simplification in the equation that must be solved at any sample time can be made. The simplified equation is:

M_n	=	$K_C * e_n$	+	$K_I * e_n + MX$	+	$K_D * (e_n - e_{n-1})$
output	=	proportional term	+	integral term	+	differential term
where:	M_n	is the calculated value of the loop output at sample time n				
	K_C	is the loop gain				
	e_n	is the value of the loop error at sample time n				
	e_{n-1}	is the previous value of the loop error (at sample time $n - 1$)				
	K_I	is the proportional constant of the integral term				
	MX	is the previous value of the integral term (at sample time $n - 1$)				
	K_D	is the proportional constant of the differential term				

The S7-200 uses a modified form of the above simplified equation when calculating the loop output value. This modified equation is:

$$M_n = MP_n + MI_n + MD_n$$

output = proportional term + integral term + differential term

where: M_n is the calculated value of the loop output at sample time n
 MP_n is the value of the proportional term of the loop output at sample time n
 MI_n is the value of the integral term of the loop output at sample time n
 MD_n is the value of the differential term of the loop output at sample time n

Understanding the Proportional Term of the PID Equation

The proportional term MP is the product of the gain (K_C), which controls the sensitivity of the output calculation, and the error (e), which is the difference between the setpoint (SP) and the process variable (PV) at a given sample time. The equation for the proportional term as solved by the S7-200 is:

$$MP_n = K_C * (SP_n - PV_n)$$

where: MP_n is the value of the proportional term of the loop output at sample time n
 K_C is the loop gain
 SP_n is the value of the setpoint at sample time n
 PV_n is the value of the process variable at sample time n

6

Understanding the Integral Term of the PID Equation

The integral term MI is proportional to the sum of the error over time. The equation for the integral term as solved by the S7-200 is:

$$MI_n = K_C * T_S / T_I * (SP_n - PV_n) + MX$$

where: MI_n is the value of the integral term of the loop output at sample time n
 K_C is the loop gain
 T_S is the loop sample time
 T_I is the integration period of the loop (also called the integral time or reset)
 SP_n is the value of the setpoint at sample time n
 PV_n is the value of the process variable at sample time n
 MX is the value of the integral term at sample time $n - 1$ (also called the integral sum or the bias)

The integral sum or bias (MX) is the running sum of all previous values of the integral term. After each calculation of MI_n , the bias is updated with the value of MI_n which might be adjusted or clamped (see the section "Variables and Ranges" for details). The initial value of the bias is typically set to the output value ($M_{initial}$) just prior to the first loop output calculation. Several constants are also part of the integral term, the gain (K_C), the sample time (T_S), which is the cycle time at which the PID loop recalculates the output value, and the integral time or reset (T_I), which is a time used to control the influence of the integral term in the output calculation.

Understanding the Differential Term of the PID Equation

The differential term MD is proportional to the change in the error. The S7-200 uses the following equation for the differential term:

$$MD_n = K_C * T_D / T_S * ((SP_n - PV_n) - (SP_{n-1} - PV_{n-1}))$$

To avoid step changes or bumps in the output due to derivative action on setpoint changes, this equation is modified to assume that the setpoint is a constant ($SP_n = SP_{n-1}$). This results in the calculation of the change in the process variable instead of the change in the error as shown:

$$MD_n = K_C * T_D / T_S * (SP_n - PV_n - SP_n + PV_{n-1})$$

or just:

$$MD_n = K_C * T_D / T_S * (PV_{n-1} - PV_n)$$

where:

MD_n	is the value of the differential term of the loop output at sample time n
K_C	is the loop gain
T_S	is the loop sample time
T_D	is the differentiation period of the loop (also called the derivative time or rate)
SP_n	is the value of the setpoint at sample time n
SP_{n-1}	is the value of the setpoint at sample time n-1
PV_n	is the value of the process variable at sample time n
PV_{n-1}	is the value of the process variable at sample time n-1

The process variable rather than the error must be saved for use in the next calculation of the differential term. At the time of the first sample, the value of PV_{n-1} is initialized to be equal to PV_n .

Selecting the Type of Loop Control

In many control systems, it might be necessary to employ only one or two methods of loop control. For example, only proportional control or proportional and integral control might be required. The selection of the type of loop control desired is made by setting the value of the constant parameters.

If you do not want integral action (no "I" in the PID calculation), then a value of infinity should be specified for the integral time (reset). Even with no integral action, the value of the integral term might not be zero, due to the initial value of the integral sum MX.

If you do not want derivative action (no "D" in the PID calculation), then a value of 0.0 should be specified for the derivative time (rate).

If you do not want proportional action (no "P" in the PID calculation) and you want I or ID control, then a value of 0.0 should be specified for the gain. Since the loop gain is a factor in the equations for calculating the integral and differential terms, setting a value of 0.0 for the loop gain will result in a value of 1.0 being used for the loop gain in the calculation of the integral and differential terms.

Converting and Normalizing the Loop Inputs

A loop has two input variables, the setpoint and the process variable. The setpoint is generally a fixed value such as the speed setting on the cruise control in your automobile. The process variable is a value that is related to loop output and therefore measures the effect that the loop output has on the controlled system. In the example of the cruise control, the process variable would be a tachometer input that measures the rotational speed of the tires.

Both the setpoint and the process variable are real world values whose magnitude, range, and engineering units could be different. Before these real world values can be operated upon by the PID instruction, the values must be converted to normalized, floating-point representations.

The first step is to convert the real world value from a 16-bit integer value to a floating-point or real number value. The following instruction sequence is provided to show how to convert from an integer value to a real number.

ITD	AIW0, AC0	//Convert an input value to a double word
DTR	AC0, AC0	//Convert the 32-bit integer to a real number

The next step is to convert the real number value representation of the real world value to a normalized value between 0.0 and 1.0. The following equation is used to normalize either the setpoint or process variable value:

$$R_{Norm} = ((R_{Raw} / Span) + Offset)$$

where:

- R_{Norm} is the normalized, real number value representation of the real world value
- R_{Raw} is the un-normalized or raw, real number value representation of the real world value
- Offset is 0.0 for unipolar values
is 0.5 for bipolar values
- Span is the maximum possible value minus the minimum possible value:
= 32,000 for unipolar values (typical)
= 64,000 for bipolar values (typical)

The following instruction sequence shows how to normalize the bipolar value in AC0 (whose span is 64,000) as a continuation of the previous instruction sequence:

/R	64000.0, AC0	//Normalize the value in the accumulator
+R	0.5, AC0	//Offset the value to the range from 0.0 to 1.0
MOVR	AC0, VD100	//Store the normalized value in the loop TABLE

Converting the Loop Output to a Scaled Integer Value

The loop output is the control variable, such as the throttle setting of the cruise control on an automobile. The loop output is a normalized, real number value between 0.0 and 1.0. Before the loop output can be used to drive an analog output, the loop output must be converted to a 16-bit, scaled integer value. This process is the reverse of converting the PV and SP to a normalized value. The first step is to convert the loop output to a scaled, real number value using the formula given below:

R_{Scal}	=	(M_n – Offset)	*	Span
where:	R _{Scal}	is the scaled, real number value of the loop output		
	M _n	is the normalized, real number value of the loop output		
	Offset	is 0.0 for unipolar values is 0.5 for bipolar values		
	Span	is the maximum possible value minus the minimum possible value = 32,000 for unipolar values (typical) = 64,000 for bipolar values (typical)		

The following instruction sequence shows how to scale the loop output:

MOVR	VD108, AC0	//Moves the loop output to the accumulator
-R	0.5, AC0	//Include this statement only if the value is bipolar
*R	64000.0, AC0	//Scales the value in the accumulator

Next, the scaled, real number value representing the loop output must be converted to a 16-bit integer. The following instruction sequence shows how to do this conversion:

ROUND	AC0, AC0	//Converts the real number to a 32-bit integer
DTI	AC0, LW0	//Converts the value to a 16-bit integer
MOVW	LW0, AQW0	//Writes the value to the analog output

Forward- or Reverse-Acting Loops

The loop is forward-acting if the gain is positive and reverse-acting if the gain is negative. (For I or ID control, where the gain value is 0.0, specifying positive values for integral and derivative time will result in a forward-acting loop, and specifying negative values will result in a reverse-acting loop.)

Variables and Ranges

The process variable and setpoint are inputs to the PID calculation. Therefore the loop table fields for these variables are read but not altered by the PID instruction.

The output value is generated by the PID calculation, so the output value field in the loop table is updated at the completion of each PID calculation. The output value is clamped between 0.0 and 1.0. The output value field can be used as an input by the user to specify an initial output value when making the transition from manual control to PID instruction (auto) control of the output. (See the discussion in the "Modes" section below).

If integral control is being used, then the bias value is updated by the PID calculation and the updated value is used as an input in the next PID calculation. When the calculated output value goes out of range (output would be less than 0.0 or greater than 1.0), the bias is adjusted according to the following formulas:

MX	=	1.0	-	(MP_n + MD_n)	<i>when the calculated output M_n > 1.0</i>
	or				
MX	=	-(MP_n + MD_n)			<i>when the calculated output M_n < 0.0</i>
where:	MX	is the value of the adjusted bias			
	MP _n	is the value of the proportional term of the loop output at sample time n			
	MD _n	is the value of the differential term of the loop output at sample time n			
	M _n	is the value of the loop output at sample time n			

By adjusting the bias as described, an improvement in system responsiveness is achieved once the calculated output comes back into the proper range. The calculated bias is also clamped between 0.0 and 1.0 and then is written to the bias field of the loop table at the completion of each PID calculation. The value stored in the loop table is used in the next PID calculation.

The bias value in the loop table can be modified by the user prior to execution of the PID instruction in order to address bias value problems in certain application situations. Care must be taken when manually adjusting the bias, and any bias value written into the loop table must be a real number between 0.0 and 1.0.

A comparison value of the process variable is maintained in the loop table for use in the derivative action part of the PID calculation. You should not modify this value.

Modes

There is no built-in mode control for S7-200 PID loops. The PID calculation is performed only when power flows to the PID box. Therefore, “automatic” or “auto” mode exists when the PID calculation is performed cyclically. “Manual” mode exists when the PID calculation is not performed.

The PID instruction has a power-flow history bit, similar to a counter instruction. The instruction uses this history bit to detect a 0-to-1 power-flow transition. When the power-flow transition is detected, it will cause the instruction to perform a series of actions to provide a bumpless change from manual control to auto control. In order for change to auto mode control to be bumpless, the value of the output as set by the manual control must be supplied as an input to the PID instruction (written to the loop table entry for M_n) before switching to auto control. The PID instruction performs the following actions to values in the loop table to ensure a bumpless change from manual to auto control when a 0-to-1 power-flow transition is detected:

- Sets setpoint (SP_n) = process variable (PV_n)
- Sets old process variable (PV_{n-1}) = process variable (PV_n)
- Sets bias (MX) = output value (M_n)

The default state of the PID history bits is “set” and that state is established at startup and on every STOP-to-RUN mode transition of the controller. If power flows to the PID box the first time that it is executed after entering RUN mode, then no power-flow transition is detected and the bumpless mode change actions are not performed.

Alarm Checking and Special Operations

The PID instruction is a simple but powerful instruction that performs the PID calculation. If other processing is required such as alarm checking or special calculations on loop variables, these must be implemented using the basic instructions supported by the S7-200.

Error Conditions

When it is time to compile, the CPU will generate a compile error (range error) and the compilation will fail if the loop table start address or PID loop number operands specified in the instruction are out of range.

Certain loop table input values are not range checked by the PID instruction. You must take care to ensure that the process variable and setpoint (as well as the bias and previous process variable if used as inputs) are real numbers between 0.0 and 1.0.

If any error is encountered while performing the mathematical operations of the PID calculation, then SM1.1 (overflow or illegal value) is set and execution of the PID instruction is terminated. (Update of the output values in the loop table could be incomplete, so you should disregard these values and correct the input value causing the mathematical error before the next execution of the loop's PID instruction.)

Loop Table

The loop table is 36 bytes long and has the format shown in Table 6-42.

Table 6-42 Loop Table

Offset	Field	Format	Type	Description
0	Process variable (PV _n)	Double word – REAL	In	Contains the process variable, which must be scaled between 0.0 and 1.0.
4	Setpoint (SP _n)	Double word – REAL	In	Contains the setpoint, which must be scaled between 0.0 and 1.0.
8	Output (M _n)	Double word – REAL	In/Out	Contains the calculated output, scaled between 0.0 and 1.0.
12	Gain (K _C)	Double word – REAL	In	Contains the gain, which is a proportional constant. Can be a positive or negative number.
16	Sample time (T _S)	Double word – REAL	In	Contains the sample time, in seconds. Must be a positive number.
20	Integral time or reset (T _I)	Double word – REAL	In	Contains the integral time or reset, in minutes. Must be a positive number.
24	Derivative time or rate (T _D)	Double word – REAL	In	Contains the derivative time or rate, in minutes. Must be a positive number.
28	Bias (MX)	Double word – REAL	In/Out	Contains the bias or integral sum value between 0.0 and 1.0.
32	Previous process variable (PV _{n-1})	Double word – REAL	In/Out	Contains the previous value of the process variable stored from the last execution of the PID instruction.

6

PID Program Example

In this example, a water tank is used to maintain a constant water pressure. Water is continuously being taken from the water tank at a varying rate. A variable speed pump is used to add water to the tank at a rate that will maintain adequate water pressure and also keep the tank from being emptied.

The setpoint for this system is a water level setting that is equivalent to the tank being 75% full. The process variable is supplied by a float gauge that provides an equivalent reading of how full the tank is and that can vary from 0% (or empty) to 100% (or completely full). The output is a value of pump speed that allows the pump to run from 0% to 100% of maximum speed.

The setpoint is predetermined and is entered directly into the loop table. The process variable is supplied as a unipolar, analog value from the float gauge. The loop output is written to a unipolar, analog output which is used to control the pump speed. The span of both the analog input and analog output is 32,000.

Only proportional and integral control are employed in this example. The loop gain and time constants have been determined from engineering calculations and can be adjusted as required to achieve optimum control. The calculated values of the time constants are: $K_C = 0.25$, $T_S = 0.1$ seconds, and $T_I = 30$ minutes.

The pump speed is controlled manually until the water tank is 75% full, then the valve is opened to allow water to be drained from the tank. At the same time, the pump is switched from manual to auto control mode. A digital input is used to switch the control from manual to auto. This input (I0.0) is manual/automatic control: 0 = manual and 1 = automatic. While in manual control mode, the pump speed is written by the operator to VD108 as a real number value from 0.0 to 1.0.

Example: PID Loop Instruction

M A I N	<p>Network 1</p>	<p>Network 1 //On the first scan, //Call the initialization subroutine</p> <pre>LD SM0.1 CALL SBR_0</pre>
S B R 0	<p>Network 1</p>	<p>Network 1 //Load PID parameters and //attach the PID interrupt routine: //1. Load the loop setpoint = 75% full. //2. Load the loop gain = 0.25. //3. Load the loop sample time = 0.1 seconds. //4. Load the integral time = 30 minutes. //5. Set no derivative action. //6. Set the timed interval (100ms) // for timed interrupt INT_0. //7. Set up a timed interrupt to invoke // the PID execution. //8. Enable interrupts</p> <pre>LD SM0.0 MOVR 0.75, VD104 MOVR 0.25, VD112 MOVR 0.1, VD116 MOVR 30.0, VD120 MOVR 0.0, VD124 MOVB 100, SMB34 ATCH INT_0, 10 ENI</pre>

Example: PID Loop Instruction, continued

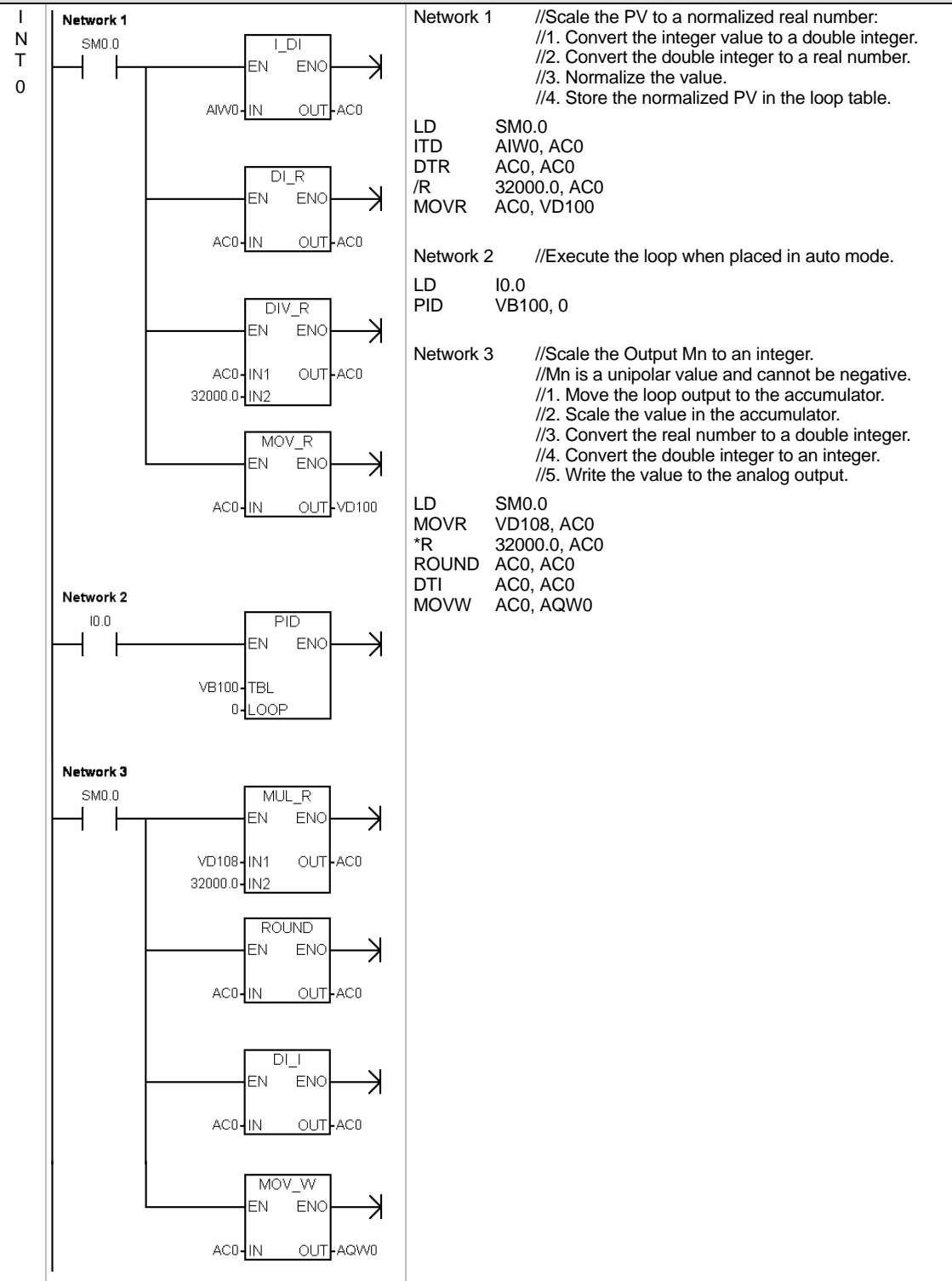

Interrupt Instructions

Enable Interrupt and Disable Interrupt

The Enable Interrupt instruction (ENI) globally enables processing of all attached interrupt events. The Disable Interrupt instruction (DISI) globally disables processing of all interrupt events.

When you make the transition to RUN mode, interrupts are initially disabled. In RUN mode, you can enable interrupt processing by executing the Enable Interrupt instruction. Executing the Disable Interrupt instruction inhibits the processing of interrupts; however, active interrupt events will continue to be queued.

Error conditions that set ENO = 0:

- 0004 (attempted execution of ENI, DISI, or HDEF instructions in an interrupt routine)

Conditional Return from Interrupt

The Conditional Return from Interrupt instruction (CRETI) can be used to return from an interrupt, based upon the condition of the preceding logic.

Attach Interrupt

The Attach Interrupt instruction (ATCH) associates an interrupt event EVNT with an interrupt routine number INT and enables the interrupt event.

Error conditions that set ENO = 0:

- 0002 (conflicting assignment of inputs to an HSC)

Detach Interrupt

The Detach Interrupt instruction (DTCH) disassociates an interrupt event EVNT from all interrupt routines and disables the interrupt event.

Table 6-43 Valid Operands for the Attach Interrupt and Detach Interrupt Instructions

Inputs/Outputs	Data Types	Operands						
INT	BYTE	Constant (0 to 127)						
EVNT	BYTE	Constant <table border="0" style="margin-left: 20px;"> <tr> <td><i>CPU 221 and CPU 222:</i></td> <td>0 to 12, 19 to 23, and 27 to 33</td> </tr> <tr> <td><i>CPU 224:</i></td> <td>0 to 23 and 27 to 33</td> </tr> <tr> <td><i>CPU 226 and CPU 226XM:</i></td> <td>0 to 33</td> </tr> </table>	<i>CPU 221 and CPU 222:</i>	0 to 12, 19 to 23, and 27 to 33	<i>CPU 224:</i>	0 to 23 and 27 to 33	<i>CPU 226 and CPU 226XM:</i>	0 to 33
<i>CPU 221 and CPU 222:</i>	0 to 12, 19 to 23, and 27 to 33							
<i>CPU 224:</i>	0 to 23 and 27 to 33							
<i>CPU 226 and CPU 226XM:</i>	0 to 33							

Operation of the Attach Interrupt and Detach Interrupt Instructions

Before an interrupt routine can be invoked, an association must be established between the interrupt event and the program segment that you want to execute when the event occurs. Use the Attach Interrupt instruction to associate an interrupt event (specified by the interrupt event number) and the program segment (specified by an interrupt routine number). You can attach multiple interrupt events to one interrupt routine, but one event cannot be concurrently attached to multiple interrupt routines.

When you attach an interrupt event to an interrupt routine, that interrupt is automatically enabled. If you disable all interrupts using the global disable interrupt instruction, each occurrence of the interrupt event is queued until interrupts are re-enabled, using the global enable interrupt instruction, or the interrupt queue overflows.

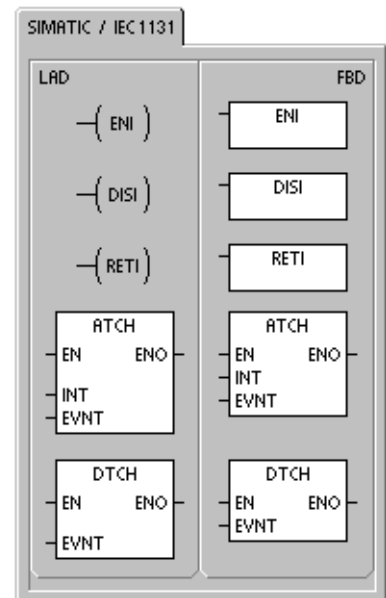

You can disable individual interrupt events by breaking the association between the interrupt event and the interrupt routine with the Detach Interrupt instruction. The Detach Interrupt instruction returns the interrupt to an inactive or ignored state. Table 6-44 lists the different types of interrupt events.

Table 6-44 Interrupt Events

Event	Description	CPU 221 CPU 222	CPU 224	CPU 226 CPU 226XM
0	I0.0 Rising edge	Y	Y	Y
1	I0.0 Falling edge	Y	Y	Y
2	I0.1 Rising edge	Y	Y	Y
3	I0.1 Falling edge	Y	Y	Y
4	I0.2 Rising edge	Y	Y	Y
5	I0.2 Falling edge	Y	Y	Y
6	I0.3 Rising edge	Y	Y	Y
7	I0.3 Falling edge	Y	Y	Y
8	Port 0 Receive character	Y	Y	Y
9	Port 0 Transmit complete	Y	Y	Y
10	Timed interrupt 0 SMB34	Y	Y	Y
11	Timed interrupt 1 SMB35	Y	Y	Y
12	HSC0 CV=PV (current value = preset value)	Y	Y	Y
13	HSC1 CV=PV (current value = preset value)		Y	Y
14	HSC1 Direction changed		Y	Y
15	HSC1 External reset		Y	Y
16	HSC2 CV=PV (current value = preset value)		Y	Y
17	HSC2 Direction changed		Y	Y
18	HSC2 External reset		Y	Y
19	PLS0 PTO pulse count complete interrupt	Y	Y	Y
20	PLS1 PTO pulse count complete interrupt	Y	Y	Y
21	Timer T32 CT=PT interrupt	Y	Y	Y
22	Timer T96 CT=PT interrupt	Y	Y	Y
23	Port 0 Receive message complete	Y	Y	Y
24	Port 1 Receive message complete			Y
25	Port 1 Receive character			Y
26	Port 1 Transmit complete			Y
27	HSC0 Direction changed	Y	Y	Y
28	HSC0 External reset	Y	Y	Y
29	HSC4 CV=PV (current value = preset value)	Y	Y	Y
30	HSC4 Direction changed	Y	Y	Y
31	HSC4 External reset	Y	Y	Y
32	HSC3 CV=PV (current value = preset value)	Y	Y	Y
33	HSC5 CV=PV (current value = preset value)	Y	Y	Y

Understanding How the S7-200 Processes Interrupt Routines

The interrupt routine is executed in response to an associated internal or external event. Once the last instruction of the interrupt routine has been executed, control is returned to the main program. You can exit the routine by executing a Conditional Return from Interrupt instruction (CRETI). Table 6-45 emphasizes some guidelines and restrictions for using interrupt routines in your program.

Table 6-45 Guidelines and Restrictions for Using Interrupt Routines

Guidelines
<p>Interrupt processing provides quick reaction to special internal or external events. You should optimize interrupt routines to perform a specific task, and then return control to the main routine.</p> <p>By keeping the interrupt routines short and to the point, execution is quick and other processes are not deferred for long periods of time. If this is not done, unexpected conditions can cause abnormal operation of equipment controlled by the main program. For interrupts, the axiom, “the shorter, the better,” is definitely true.</p>
Restrictions
<p>You cannot use the Disable Interrupt (DISI), Enable Interrupt (ENI), High-Speed Counter Definition (HDEF), and End (END) instructions in an interrupt routine.</p>

System Support for Interrupts

Because contact, coil, and accumulator logic can be affected by interrupts, the system saves and reloads the logic stack, accumulator registers, and the special memory bits (SM) that indicate the status of accumulator and instruction operations. This avoids disruption to the main user program caused by branching to and from an interrupt routine.

Sharing Data Between the Main Program and Interrupt Routines

You can share data between the main program and one or more interrupt routines. Because it is not possible to predict when the S7-200 might generate an interrupt, it is desirable to limit the number of variables that are used by both the interrupt routine and elsewhere in the program. Problems with the consistency of shared data can result due to the actions of interrupt routines when the execution of instructions in your main program is interrupted by interrupt events. Use the local variable table of the interrupt routine to ensure that your interrupt routine uses only the temporary memory and does not overwrite data used somewhere else in your program.

There are a number of programming techniques you can use to ensure that data is correctly shared between your main program and interrupt routines. These techniques either restrict the way access is made to shared memory locations or prevent interruption of instruction sequences using shared memory locations.

- For an STL program that is sharing a single variable: If the shared data is a single byte, word, or double word variable and your program is written in STL, then correct shared access can be ensured by storing the intermediate values from operations on shared data only in non-shared memory locations or accumulators.
- For a LAD program that is sharing a single variable: If the shared data is a single byte, word, or double word variable and your program is written in LAD, then correct shared access can be ensured by establishing the convention that access to shared memory locations be made using only Move instructions (MOVB, MOVW, MOVD, MOVR). While many LAD instructions are composed of interruptible sequences of STL instructions, these Move instructions are composed of a single STL instruction whose execution cannot be affected by interrupt events.
- For an STL or LAD program that is sharing multiple variables: If the shared data is composed of a number of related bytes, words, or double words, then the interrupt disable/enable instructions (DISI and ENI) can be used to control interrupt routine execution. At the point in your main program where operations on shared memory locations are to begin, disable the interrupts. Once all actions affecting the shared locations are complete, re-enable the interrupts. During the time that interrupts are disabled, interrupt routines cannot be executed and therefore cannot access shared memory locations; however, this approach can result in delayed response to interrupt events.

Calling Subroutines from Interrupt Routines

You can call one nesting level of subroutines from an interrupt routine. The accumulators and the logic stack are shared between an interrupt routine and a subroutine that is called.

Types of Interrupts Supported by the S7-200

The S7-200 supports the following types of interrupt routines:

- Communications port interrupts: The S7-200 generates events that allow your program to control the communications port.
- I/O interrupts: The S7-200 generates events for different changes of state for various I/O. These events allow your program to respond to the high-speed counters, the pulse outputs, or to rising or falling states of the inputs.
- Time-based interrupts: The S7-200 generates events that allow your program to react at specific intervals.

Communications Port Interrupts

The serial communications port of the S7-200 can be controlled by your program. This mode of operating the communications port is called Freeport mode. In Freeport mode, your program defines the baud rate, bits per character, parity, and protocol. The Receive and Transmit interrupts are available to facilitate your program-controlled communications. Refer to the Transmit and Receive instructions for more information.

I/O Interrupts

I/O interrupts include rising/falling edge interrupts, high-speed counter interrupts, and pulse train output interrupts. The S7-200 can generate an interrupt on rising and/or falling edges of an input (either I0.0, I0.1, I0.2, or I0.3). The rising edge and the falling edge events can be captured for each of these input points. These rising/falling edge events can be used to signify a condition that must receive immediate attention when the event happens.

The high-speed counter interrupts allow you to respond to conditions such as the current value reaching the preset value, a change in counting direction that might correspond to a reversal in the direction in which a shaft is turning, or an external reset of the counter. Each of these high-speed counter events allows action to be taken in real time in response to high-speed events that cannot be controlled at programmable logic controller scan speeds.

The pulse train output interrupts provide immediate notification of completion of outputting the prescribed number of pulses. A typical use of pulse train outputs is stepper motor control.

You can enable each of the above interrupts by attaching an interrupt routine to the related I/O event.

Time-Based Interrupts

Time-based interrupts include timed interrupts and the timer T32/T96 interrupts. You can specify actions to be taken on a cyclic basis using a timed interrupt. The cycle time is set in 1-ms increments from 1 ms to 255 ms. You must write the cycle time in SMB34 for timed interrupt 0, and in SMB35 for timed interrupt 1.

The timed interrupt event transfers control to the appropriate interrupt routine each time the timer expires. Typically, you use timed interrupts to control the sampling of analog inputs or to execute a PID loop at regular intervals.

A timed interrupt is enabled and timing begins when you attach an interrupt routine to a timed interrupt event. During the attachment, the system captures the cycle time value, so subsequent changes to SMB34 and SMB35 do not affect the cycle time. To change the cycle time, you must modify the cycle time value, and then re-attach the interrupt routine to the timed interrupt event. When the re-attachment occurs, the timed interrupt function clears any accumulated time from the previous attachment and begins timing with the new value.

After being enabled, the timed interrupt runs continuously, executing the attached interrupt routine on each expiration of the specified time interval. If you exit RUN mode or detach the timed interrupt, the timed interrupt is disabled. If the global disable interrupt instruction is executed, timed interrupts continue to occur. Each occurrence of the timed interrupt is queued (until either interrupts are enabled or the queue is full).

The timer T32/T96 interrupts allow timely response to the completion of a specified time interval. These interrupts are only supported for the 1-ms resolution on-delay (TON) and off-delay (TOF) timers T32 and T96. The T32 and T96 timers otherwise behave normally. Once the interrupt is enabled, the attached interrupt routine is executed when the active timer's current value becomes equal to the preset time value during the normal 1-ms timer update performed in the S7-200. You enable these interrupts by attaching an interrupt routine to the T32/T96 interrupt events.

Interrupt Priority and Queuing

Interrupts are serviced by the S7-200 on a first-come-first-served basis within their respective priority group. Only one user-interrupt routine is ever being executed at any point in time. Once the execution of an interrupt routine begins, the routine is executed to completion. It cannot be pre-empted by another interrupt routine, even by a higher priority routine. Interrupts that occur while another interrupt is being processed are queued for later processing.

Table 6-46 shows the three interrupt queues and the maximum number of interrupts they can store.

Table 6-46 Maximum Number of Entries per Interrupt Queue

Queue	CPU 221, CPU 222, CPU 224	CPU 226 and CPU 226XM
Communications queue	4	8
I/O Interrupt queue	16	16
Timed Interrupt queue	8	8

Potentially, more interrupts can occur than the queue can hold. Therefore, queue overflow memory bits (identifying the type of interrupt events that have been lost) are maintained by the system. Table 6-47 shows the interrupt queue overflow bits. You should use these bits only in an interrupt routine because they are reset when the queue is emptied, and control is returned to the main program.

Table 6-48 shows all interrupt events, with their priority and assigned event number.

Table 6-47 Interrupt Queue Overflow Bits

Description (0 = No Overflow, 1 = Overflow)	SM Bit
Communications queue	SM4.0
I/O Interrupt queue	SM4.1
Timed Interrupt queue	SM4.2

Table 6-48 Priority Order for Interrupt Events

Event	Description	Priority Group	Priority in Group
8	Port 0 Receive character	Communications <i>Highest Priority</i>	0
9	Port 0 Transmit complete		0
23	Port 0 Receive message complete		0
24	Port 1 Receive message complete		1
25	Port 1 Receive character		1
26	Port 1 Transmit complete		1
19	PLS0 PTO pulse count complete interrupt	Discrete <i>Medium Priority</i>	0
20	PLS1 PTO pulse count complete interrupt		1
0	I0.0 Rising edge		2
2	I0.1 Rising edge		3
4	I0.2 Rising edge		4
6	I0.3 Rising edge		5
1	I0.0 Falling edge		6
3	I0.1 Falling edge		7
5	I0.2 Falling edge		8
7	I0.3 Falling edge		9
12	HSC0 CV=PV (current value = preset value)		10
27	HSC0 Direction changed		11
28	HSC0 External reset		12
13	HSC1 CV=PV (current value = preset value)		13
14	HSC1 Direction changed		14
15	HSC1 External reset		15
16	HSC2 CV=PV (current value = preset value)		16
17	HSC2 Direction changed		17
18	HSC2 External reset		18
32	HSC3 CV=PV (current value = preset value)		19
29	HSC4 CV=PV (current value = preset value)		20
30	HSC4 Direction changed		21
31	HSC4 External reset		22
33	HSC5 CV=PV (current value = preset value)	23	
10	Timed interrupt 0 SMB34	Timed <i>Lowest Priority</i>	0
11	Timed interrupt 1 SMB35		1
21	Timer T32 CT=PT interrupt		2
22	Timer T96 CT=PT interrupt		3

Example: Interrupt Instructions

M A I N	<p>Network 1</p> <p>Network 2</p> <p>Network 3</p>	<p>Network 1 //On the first scan: //1. Define interrupt routine INT_0 to be a falling-edge interrupt for I0.0 //2. Globally enable interrupts.</p> <pre>LD SM0.1 ATCH INT_0, 1 ENI</pre> <p>Network 2 //If an I/O error is detected, //disable the falling-edge interrupt for I0.0. //This network is optional.</p> <pre>LD SM5.0 DTCH 1</pre> <p>Network 3 //When M5.0 is on, //disable all interrupts.</p> <pre>LD M5.0 DISI</pre>
I N T 0	<p>Network 1</p>	<p>Network 1 //I0.0 falling-edge interrupt routine: //Conditional return based on an I/O error.</p> <pre>LD SM5.0 CRETI</pre>

Example: Timed Interrupt for Reading the Value of an Analog Input

M A I N	<p>Network 1</p>	<p>Network 1 //On the first scan, call subroutine 0.</p> <pre>LD SM0.1 CALL SBR_0</pre>
S B R 0	<p>Network 1</p>	<p>Network 1 //1. Set the interval for the timed interrupt 0 to 100 ms. //2. Attach timed interrupt 0 (Event 10) to INT_0. //3. Global interrupt enable.</p> <pre>LD SM0.0 MOVB 100, SMB34 ATCH INT_0, 10 ENI</pre>
I N T 0	<p>Network 1</p>	<p>Network 1 //Read the value of AIW4 every 100 ms</p> <pre>LD SM0.0 MOVW AIW4, VW100</pre>

Logical Operations Instructions

Invert Instructions

Invert Byte, Word, and Double Word

The Invert Byte (INVB), Invert Word (INVW), and Invert Double Word (INVD) instructions form the one's complement of the input IN and load the result into the memory location OUT.

Error conditions that set ENO = 0

- 0006 (indirect address)

SM bits affected:

- SM1.0 (zero)

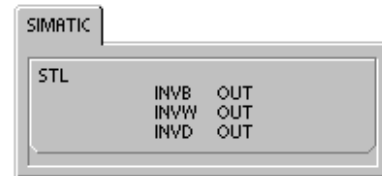
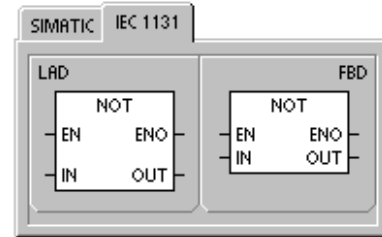
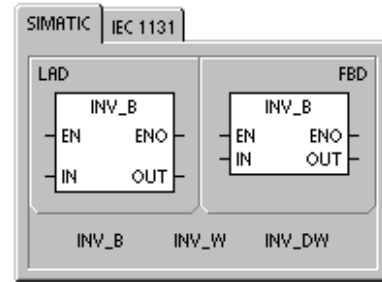

Table 6-49 Valid Operands for the Invert Instructions

Inputs/Outputs	Data Types	Operands
IN	BYTE WORD DWORD	IB, QB, VB, MB, SMB, SB, LB, AC, *VD, *LD, *AC, Constant IW, QW, VW, MW, SMW, SW, T, C, LW, AC, AIW, *VD, *LD, *AC, Constant ID, QD, VD, MD, SMD, SD, LD, AC, HC, *VD, *LD, *AC, Constant
OUT	BYTE WORD DWORD	IB, QB, VB, MB, SMB, SB, LB, AC, *VD, *LD, *AC IW, QW, VW, MW, SMW, SW, T, C, LW, AC, *VD, *LD, *AC ID, QD, VD, MD, SMD, SD, LD, AC, *VD, *LD, *AC

Example: Invert Instruction	
<p>Network 1</p>	<p>Network 1</p> <pre>LD I4.0 INVW AC0</pre> <p>Invert Word</p> <p>AC0 1101 0111 1001 0101</p> <p> complement</p> <p>AC0 0010 1000 0110 1010</p>

AND, OR, and Exclusive OR Instructions

AND Byte, AND Word, and AND Double Word

The AND Byte (ANDB), AND Word (ANDW), and AND Double Word (ANDD) instructions AND the corresponding bits of two input values IN1 and IN2 and load the result in a memory location OUT.

OR Byte, OR Word and OR Double Word

The OR Byte (ORB), OR Word instruction (ORW), and OR Double Word (ORD) instructions OR the corresponding bits of two input values IN1 and IN2 and load the result in a memory location OUT.

Exclusive OR Byte, Exclusive OR Word, and Exclusive OR Double Word

The Exclusive OR Byte (XROB), Exclusive OR Word (XORW), and Exclusive OR Double Word (XORD) instruction XOR the corresponding bits of two input values IN1 and IN2 and load the result in a memory location OUT.

SM Bits and ENO

For all of the instructions described on this page, the following conditions affect SM bits and ENO.

Error conditions that set ENO = 0

- 0006 (indirect address)

SM bits affected:

- SM1.0 (zero)

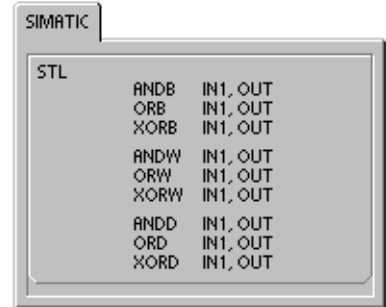
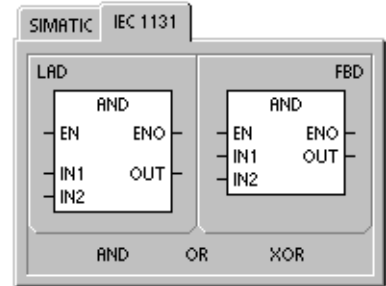
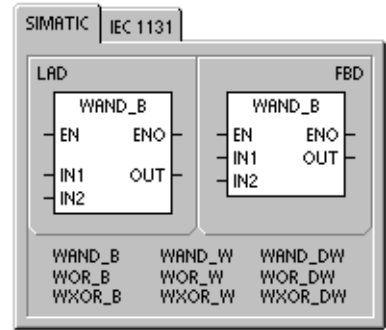

6

Table 6-50 Valid Operands for the AND, OR, and Exclusive OR Instructions

Inputs/Outputs	Data Types	Operands
IN1, IN2	BYTE	IB, QB, VB, MB, SMB, SB, LB, AC, *VD, *LD, *AC, Constant
	WORD	IW, QW, VW, MW, SMW, SW, T, C, LW, AC, AIW, *VD, *LD, *AC, Constant
	DWORD	ID, QD, VD, MD, SMD, SD, LD, AC, HC, *VD, *LD, *AC, Constant
OUT	BYTE	IB, QB, VB, MB, SMB, SB, LB, AC, *VD, *AC, *LD
	WORD	IW, QW, VW, MW, SMW, SW, T, C, LW, AC, *VD, *AC, *LD
	DWORD	ID, QD, VD, MD, SMD, SD, LD, AC, *VD, *AC, *LD

Example: AND, OR, and Exclusive OR Instructions

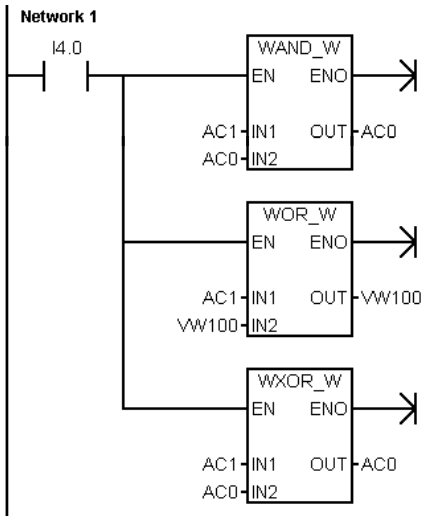

Network 1

```

LD      I4.0
ANDW   AC1, AC0
ORW    AC1, VW100
XORW   AC1, AC0
    
```

AND Word	OR Word
AC1 0001 1111 0110 1101	AC1 0001 1111 0110 1101
AND	OR
AC0 1101 0011 1110 0110	VW100 1101 0011 1010 0000
equals	equals
AC0 0001 0011 0110 0100	VW100 1101 1111 1110 1101
Exclusive OR Word	
AC1 0001 1111 0110 1101	
XOR	
AC0 0001 0011 0110 0100	
equals	
AC0 0000 1100 0000 1001	

6

Move Instructions

Move Byte, Word, Double Word, or Real

The Move Byte (MOVB), Move Word (MOVW), Move Double Word (MOVD), and Move Real (MOVR) instructions move a value from a memory location IN to a new memory location OUT without changing the original value.

Use the Move Double Word instruction to create a pointer. For more information, refer to the section on pointers and indirect addressing in Chapter 4.

For the IEC Move instruction, the input and output data types can vary, but must be of the same size.

Error conditions that set ENO = 0

- 0006 (indirect address)

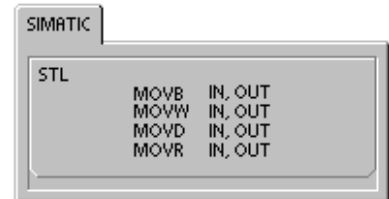
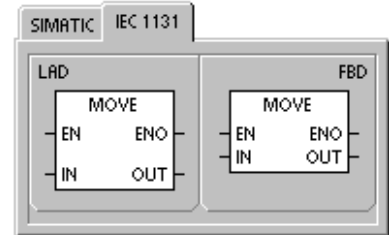
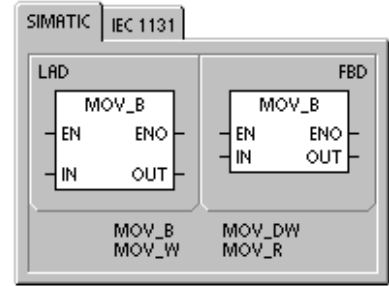

6

Table 6-51 Valid Operands for the Move Instructions

Inputs/Outputs	Data Types	Operands
IN	BYTE WORD, INT DWORD, DINT REAL	IB, QB, VB, MB, SMB, SB, LB, AC, *VD, *LD, *AC, Constant IW, QW, VW, MW, SMW, SW, T, C, LW, AC, AIW, *VD, *AC, *LD, Constant ID, QD, VD, MD, SMD, SD, LD, AC, HC, &IB, &QB, &VB, &MB, &SB, &T, &C, *VD, *LD, *AC, Constant ID, QD, VD, MD, SMD, SD, LD, AC, *VD, *LD, *AC, Constant
OUT	BYTE WORD, INT DWORD, DINT, REAL	IB, QB, VB, MB, SMB, SB, LB, AC, *VD, *LD, *AC IW, QW, VW, MW, SMW, SW, T, C, LW, AC, AQW, *VD, *LD, *AC ID, QD, VD, MD, SMD, SD, LD, AC, *VD, *LD, *AC

Move Byte Immediate (Read and Write)

The Move Byte Immediate instructions allow you to immediately move a byte between the physical I/O and a memory location.

The Move Byte Immediate Read (BIR) instruction reads physical input (IN) and writes the result to the memory address (OUT), but the process-image register is not updated.

The Move Byte Immediate Write instruction (BIW) reads the data from the memory address (IN) and writes to physical output (OUT), and the corresponding process image location.

Error conditions that set ENO = 0

- 0006 (indirect address)
- Unable to access expansion module

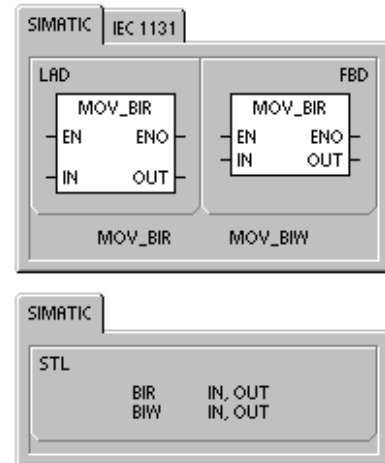

Table 6-52 Valid Operands for the Move Byte Immediate Read Instruction

Inputs/Outputs	Data Types	Operands
IN	BYTE	IB, *VD, *LD, *AC
OUT	BYTE	IB, QB, VB, MB, SMB, SB, LB, AC, *VD, *LD, *AC

Table 6-53 Valid Operands for the Move Byte Immediate Write Instruction

Inputs/Outputs	Data Types	Operands
IN	BYTE	IB, QB, VB, MB, SMB, SB, LB, AC, *VD, *LD, *AC, Constant
OUT	BYTE	QB, *VD, *LD, *AC

Block Move Instructions

Block Move Byte, Word, or Double Word

The Block Move Byte (BMB), Block Move Word (BMW), and Block Move Double Word (BMD) instructions move a specified amount of data to a new memory location by moving the number of bytes, words, or double words N starting at the input address IN to a new block starting at the output address OUT.

N has a range of 1 to 255.

Error conditions that set ENO = 0

- 0006 (indirect address)
- 0091 (operand out of range)

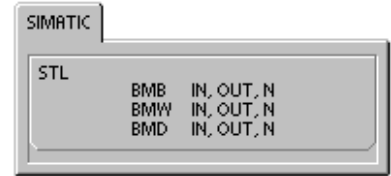
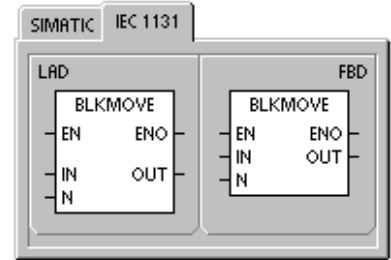
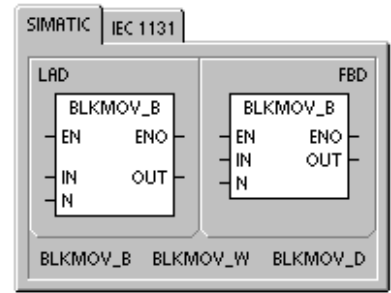

6

Table 6-54 Valid Operands for the Block Move Instructions

Inputs/Outputs	Data Types	Operands
IN	BYTE WORD, INT DWORD, DINT	IB, QB, VB, MB, SMB, SB, LB, *VD, *LD, *AC IW, QW, VW, MW, SMW, SW, T, C, LW, AIW, *VD, *LD, *AC ID, QD, VD, MD, SMD, SD, LD, *VD, *LD, *AC
OUT	BYTE WORD, INT DWORD, DINT	IB, QB, VB, MB, SMB, SB, LB, *VD, *LD, *AC IW, QW, VW, MW, SMW, SW, T, C, LW, AQW, *VD, *LD, *AC ID, QD, VD, MD, SMD, SD, LD, *VD, *LD, *AC
N	BYTE	IB, QB, VB, MB, SMB, SB, LB, AC, Constant, *VD, *LD, *AC

Example: Block Move Instruction																										
<p>Network 1</p>	<p>Network 1 //Move array 1 (VB20 to VB23) //to array 2 (VB100 to VB103)</p> <pre>LD I2.1 BMB VB20, VB100, 4</pre> <table style="margin-left: 40px;"> <tr> <td></td> <td>VB20</td> <td>VB21</td> <td>VB22</td> <td>VB23</td> </tr> <tr> <td>Array 1</td> <td>30</td> <td>31</td> <td>32</td> <td>33</td> </tr> <tr> <td>↓</td> <td></td> <td></td> <td></td> <td></td> </tr> <tr> <td>Array 2</td> <td>VB100</td> <td>VB101</td> <td>VB102</td> <td>VB103</td> </tr> <tr> <td></td> <td>30</td> <td>31</td> <td>32</td> <td>33</td> </tr> </table>		VB20	VB21	VB22	VB23	Array 1	30	31	32	33	↓					Array 2	VB100	VB101	VB102	VB103		30	31	32	33
	VB20	VB21	VB22	VB23																						
Array 1	30	31	32	33																						
↓																										
Array 2	VB100	VB101	VB102	VB103																						
	30	31	32	33																						

Program Control Instructions

Conditional End

The Conditional End instruction (END) terminates the current scan based upon the condition of the preceding logic. You can use the Conditional End instruction in the main program, but you cannot use it in either subroutines or interrupt routines.

Stop

The Stop instruction (STOP) terminates the execution of your program by causing a transition of the S7-200 CPU from RUN to STOP mode.

If the Stop instruction is executed in an interrupt routine, the interrupt routine is terminated immediately, and all pending interrupts are ignored. Remaining actions in the current scan cycle are completed, including execution of the main user program, and the transition from RUN to STOP mode is made at the end of the current scan.

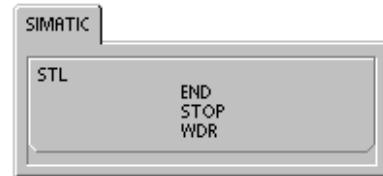
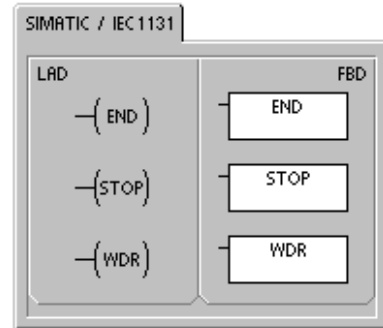

6

Watchdog Reset

The Watchdog Reset instruction (WDR) retriggers the system watchdog timer of the S7-200 CPU to extend the time that the scan is allowed to take without getting a watchdog error.

You should use the Watchdog Reset instruction carefully. If you use looping instructions either to prevent scan completion or to delay excessively the completion of the scan, the following processes are inhibited until the scan cycle is completed:

- Communications (except Freeport Mode)
- I/O updating (except Immediate I/O)
- Force updating
- SM bit updating (SM0, SM5 to SM29 are not updated)
- Run-time diagnostics
- 10-ms and 100-ms timers will not properly accumulate time for scans exceeding 25 seconds
- STOP instruction, when used in an interrupt routine
- Expansion modules with discrete outputs also include a watchdog timer that turns off outputs if the module is not written by the S7-200. Use an immediate write to each expansion module with discrete outputs to keep the correct outputs on during extended scan times. Refer to the example that follows this description.



Tip

If you expect your scan time to exceed 500 ms, or if you expect a burst of interrupt activity that could prevent returning to the main scan for more than 500 ms, you should use the Watchdog Reset instruction to retrigger the watchdog timer.

Each time you use the Watchdog Reset instruction, you should also use an immediate write to one output byte (QB) in each discrete expansion module to reset each expansion module watchdog.

If you use the Watchdog Reset instruction to allow the execution of a program that requires a long scan time, changing the mode switch to the STOP position causes the S7-200 to transition to STOP mode within 1.4 seconds.

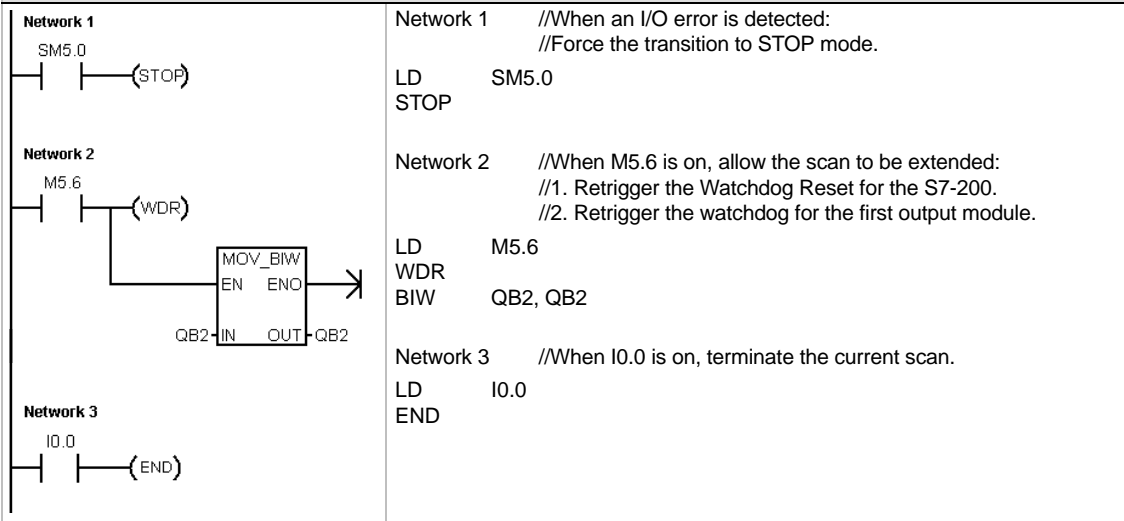
Example: Stop, End, and Watchdog Reset Instructions

For–Next Loop Instructions

Use the For (FOR) and Next (NEXT) instructions to delineate a loop that is repeated for the specified count. Each For instruction requires a Next instruction. You can nest For–Next loops (place a For–Next loop within a For–Next loop) to a depth of eight.

The For instruction executes the instructions between the For and the Next instructions. You specify the index value or current loop count INDX, the starting value INIT, and the ending value FINAL.

The Next instruction marks the end of the FOR loop.

Error conditions that set ENO = 0

- 0006 (indirect address)

If you enable the For–Next loop, it continues the looping process until it finishes the iterations, unless you change the final value from within the loop itself. You can change the values while the For–Next loop is in the looping process. When the loop is enabled again, it copies the initial value into the index value (current loop number).

The For–Next instruction resets itself the next time it is enabled.

For example, given an INIT value of 1 and a FINAL value of 10, the instructions between the For instruction and the Next instruction are executed 10 times with the INDX value being incremented: 1, 2, 3, ...10.

If the starting value is greater than the final value, the loop is not executed. After each execution of the instructions between the For instruction and the Next instruction, the INDX value is incremented and the result is compared to the final value. If the INDX is greater than the final value, the loop is terminated.

If the top of stack is 1 when your program enters the For–Next loop, then the top of stack will be 1 when your program exits the For–Next loop.

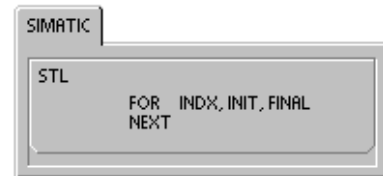
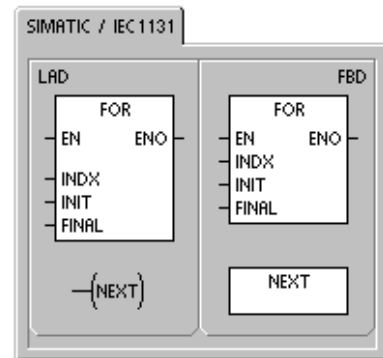

6

Table 6-55 Valid Operands for the For and Next Instructions

Inputs/Outputs	Data Types	Operands
INDX	INT	IW, QW, VW, MW, SMW, SW, T, C, LW, AC, *VD, *LD, *AC
INIT, FINAL	INT	VW, IW, QW, MW, SMW, SW, T, C, LW, AC, AIW, *VD, *LD, *AC, Constant

Example: For-Next Loop Instructions

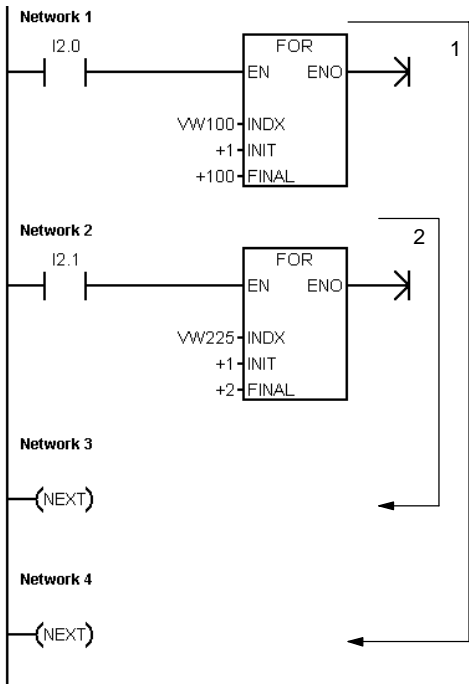

Network 1 //When I2.0 comes on, the outside loop
//(arrow 1) is executed 100 times

```
LD I2.0
FOR VW100, +1, +100
```

Network 2 //The inside loop (arrow 2) is executed twice
//for each execution of the outside loop
//when I2.1 is on.

```
LD I2.1
FOR VW225, +1, +2
```

Network 3 //End of Loop 2.
NEXT

Network 4 //End of Loop 1 .
NEXT

Jump Instructions

The Jump to Label instruction (JMP) performs a branch to the specified label N within the program.

The Label instruction (LBL) marks the location of the jump destination N.

You can use the Jump instruction in the main program, in subroutines, or in interrupt routines. The Jump and its corresponding Label instruction must always be located within the same segment of code (either the main program, a subroutine, or an interrupt routine).

You cannot jump from the main program to a label in either a subroutine or an interrupt routine. Likewise, you cannot jump from a subroutine or interrupt routine to a label outside that subroutine or interrupt routine.

You can use a Jump instruction within an SCR segment, but the corresponding Label instruction must be located within the same SCR segment.

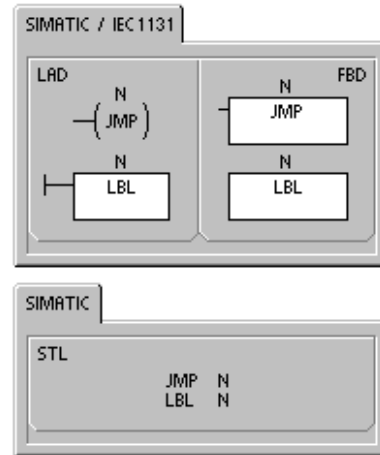

Table 6-56 Valid Operands for the Jump Instructions

Inputs/Outputs	Data Types	Operands
N	WORD	Constant (0 to 255)

Example: Jump to Label Instruction

<p>Network 1</p> <p>Network 2</p>	<p>Network 1 //If the retentive data has not been lost, Jump to LBL4</p> <p>LDN SM0.2</p> <p>JMP 4</p> <p>Network 2</p> <p>LBL 4</p>
---	--

Sequence Control Relay (SCR) Instructions

SCR instructions provide you with a simple yet powerful state control programming technique that fits naturally into a LAD, FBD, or STL program.

Whenever your application consists of a sequence of operations that must be performed repetitively, SCRs can be used to structure your program so that it corresponds directly to your application. As a result, you can program and debug your application more quickly and easily.

The Load SCR instruction (LSCR) loads the SCR and logic stacks with the value of the S bit referenced by the instruction N.

The SCR segment is energized or de-energized by the resulting value of the SCR stack. The value of the SCR stack is copied to the top of the logic stack so that boxes or output coils can be tied directly to the left power rail without an intervening contact.

Restrictions

When using SCRs, be aware of the following restrictions:

- You cannot use the same S bit in more than one routine. For example, if you use S0.1 in the main program, do not use it in a subroutine.
- You cannot jump into or out of an SCR segment; however, you can use Jump and Label instructions to jump around SCR segments or to jump within an SCR segment.
- You cannot use the END instruction in an SCR segment.

Table 6-57 Valid Operands for the Sequence Control Relay Instructions

Inputs/Outputs	Data Types	Operands
S_bit	BOOL	S

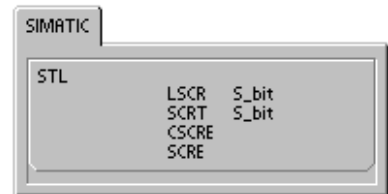
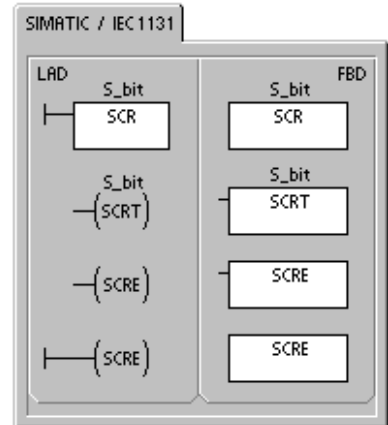

Figure 6-31 shows the S stack and the logic stack and the effect of executing the Load SCR instruction. The following is true of Sequence Control Relay instructions:

- ❑ The Load SCR instruction (LSCR) marks the beginning of an SCR segment, and the SCR End instruction (SCRE) marks the end of an SCR segment. All logic between the Load SCR and the SCR End instructions are dependent upon the value of the S stack for its execution. Logic between the SCR End and the next Load SCR instruction is not dependent on the value of the S stack.

- ❑ The SCR Transition instruction (SCRT) provides the means to transfer control from an active SCR segment to another SCR segment.

Execution of the SCR Transition instruction when it has power flow will reset the S bit of the currently active segment and will set the S bit of the referenced segment.

Resetting the S bit of the active segment does not affect the S stack at the time the SCR Transition instruction executes.

Consequently, the SCR segment remains energized until it is exited.

Load the value of Sx.y onto the SCR and logic stacks.

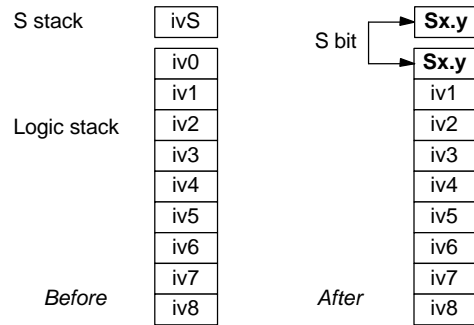
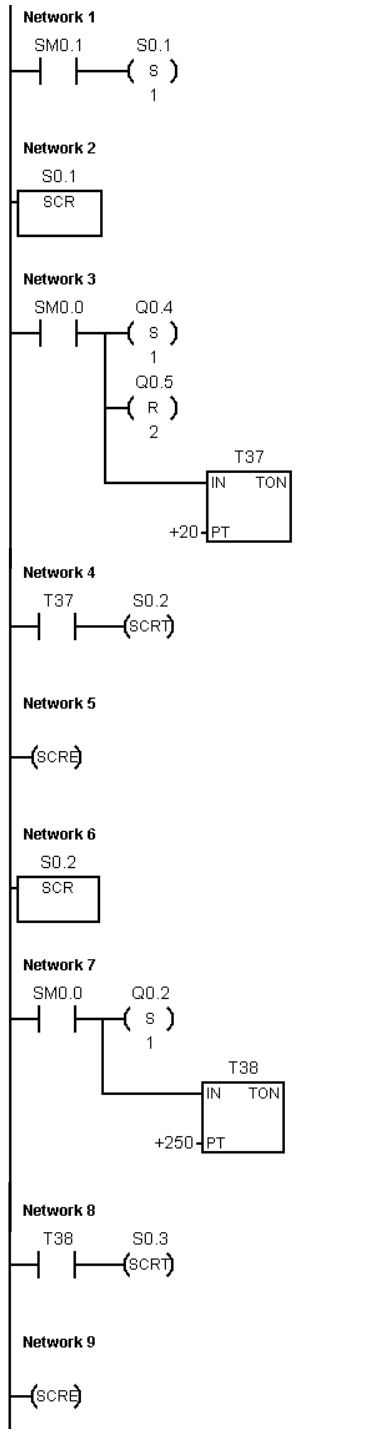

Figure 6-31 Effect of LSCR on the Logic Stack

- ❑ The Conditional SCR End instruction (CSCRE) provides a means to exit an active SCR segment without executing the instructions between the Conditional SCR End and the SCR End instructions. The Conditional SCR End instruction does not affect any S bit nor does it affect the S stack.

In the following example, the first scan bit SM0.1 sets S0.1, which will be the active State 1 on the first scan. After a 2-second delay, T37 causes a transition to State 2. This transition deactivates the State 1 SCR (S0.1) segment and activates the State 2 SCR (S0.2) segment.

Example: Sequence Control Relay Instruction



```

Network 1 //On the first scan enable State 1.
LD SM0.1
S S0.1, 1

Network 2 //Beginning of State 1 control region.
LSCR S0.1

Network 3 //Control the signals for Street 1:
//1. Set: Turn on the red light.
//2. Reset: Turn off the yellow and green lights.
//3. Start a 2-second timer.
LD SM0.0
S Q0.4, 1
R Q0.5, 2
TON T37, +20

Network 4 //After a 2 second delay, transition to State 2.
LD T37
SCRT S0.2

Network 5 //End of SCR region for State 1.
SCRE

Network 6 //Beginning of State 2 control region.
LSCR S0.2

Network 7 //Control the signals for Street 2:
//1. Set: Turn on the green light.
//2. Start a 25-second timer.
LD SM0.0
S Q0.2, 1
TON T38, +250

Network 8 //After a 25 second delay, transition to State 3.
LD T38
SCRT S0.3

Network 9 //End of SCR region for State 2.
SCRE
    
```

In other situations, a control stream might be directed into one of several possible control streams, depending upon which transition condition comes true first. Such a situation is depicted in Figure 6-34, which shows an equivalent SCR program.

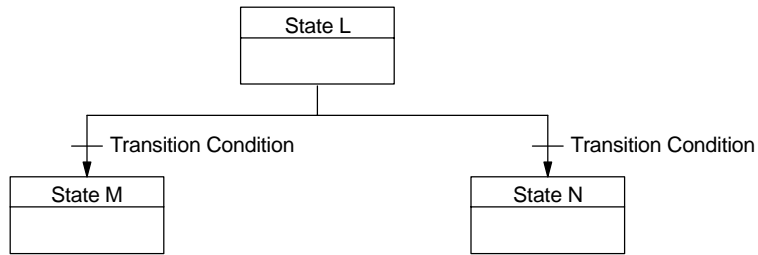
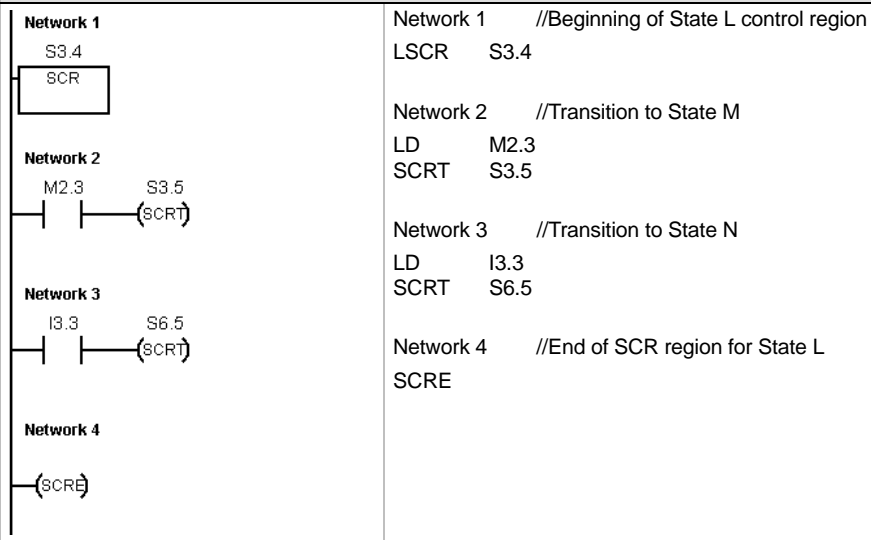

Figure 6-34 Divergence of a Control Stream, Depending on the Transition Condition

6

Example: Conditional Transitions



Shift and Rotate Instructions

Shift Right and Shift Left Instructions

The Shift instructions shift the input value IN right or left by the shift count N and load the result in the output OUT.

The Shift instructions fill with zeros as each bit is shifted out. If the shift count (N) is greater than or equal to the maximum allowed (8 for byte operations, 16 for word operations, and 32 for double word operations), the value is shifted the maximum number of times for the operation. If the shift count is greater than 0, the overflow memory bit (SM1.1) takes on the value of the last bit shifted out. The zero memory bit (SM1.0) is set if the result of the shift operation is zero.

Byte operations are unsigned. For word and double word operations, the sign bit is shifted when you use signed data types.

Error conditions that set ENO = 0

- 0006 (indirect address)

SM bits affected:

- SM1.0 (zero)
- SM1.1 (overflow)

Rotate Right and Rotate Left Instructions

The Rotate instructions rotate the input value (IN) right or left by the shift count (N) and load the result in the memory location (OUT). The rotate is circular.

If the shift count is greater than or equal to the maximum for the operation (8 for a byte operation, 16 for a word operation, or 32 for a double-word operation), the S7-200 performs a modulo operation on the shift count to obtain a valid shift count before the rotation is executed. This result is a shift count of 0 to 7 for byte operations, 0 to 15 for word operations, and 0 to 31 for double-word operations.

If the shift count is 0, a rotate operation is not performed. If the rotate operation is performed, the value of the last bit rotated is copied to the overflow bit (SM1.1).

If the shift count is not an integer multiple of 8 (for byte operations), 16 (for word operations), or 32 (for double-word operations), the last bit rotated out is copied to the overflow memory bit (SM1.1). The zero memory bit (SM1.0) is set when the value to be rotated is zero.

Byte operations are unsigned. For word and double word operations, the sign bit is shifted when you use signed data types.

Error conditions that set ENO = 0

- 0006 (indirect address)

SM bits affected:

- SM1.0 (zero)
- SM1.1 (overflow)

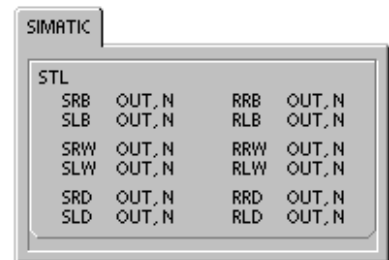
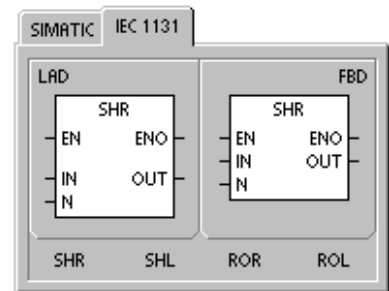
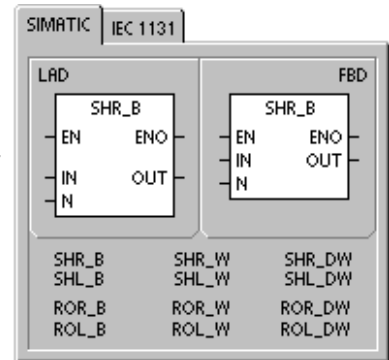

Table 6-58 Valid Operands for the Shift and Rotate Instructions

Inputs/Outputs	Data Types	Operands
IN	BYTE WORD DWORD	IB, QB, VB, MB, SMB, SB, LB, AC, *VD, *LD, *AC, Constant IW, QW, VW, MW, SMW, SW, T, C, LW, AC, AIW, *VD, *LD, *AC, Constant ID, QD, VD, MD, SMD, SD, LD, AC, HC, *VD, *LD, *AC, Constant
OUT	BYTE WORD DWORD	IB, QB, VB, MB, SMB, SB, LB, AC, *VD, *LD, *AC IW, QW, VW, MW, SMW, SW, T, C, LW, AC, *VD, *LD, *AC ID, QD, VD, MD, SMD, SD, LD, AC, *VD, *LD, *AC
N	BYTE	IB, QB, VB, MB, SMB, SB, LB, AC, *VD, *LD, *AC, Constant

Example: Shift and Rotate Instructions

Network 1

Network 1

```

LD    I4.0
RRW  AC0, 2
SLW  VW200, 3
        
```

Rotate

	Before rotate	Overflow
AC0	0100 0000 0000 0001	x
AC0	After first rotate 1010 0000 0000 0000	1
AC0	After second rotate 0101 0000 0000 0000	0

Zero Memory Bit (SM1.0) = 0
Overflow Memory Bit (SM1.1) = 0

Shift

	Before shift	Overflow
VW200	1110 0010 1010 1101	x
VW200	After first shift 1100 0101 0101 1010	1
VW200	After second shift 1000 1010 1011 0100	1
VW200	After third shift 0001 0101 0110 1000	1

Zero Memory Bit (SM1.0) = 0
Overflow Memory Bit (SM1.1) = 1

Shift Register Bit Instruction

The Shift Register Bit instruction shifts a value into the Shift Register. This instruction provides an easy method for sequencing and controlling product flow or data. Use this instruction to shift the entire register one bit, once per scan.

The Shift Register Bit instruction shifts the value of DATA into the Shift Register. S_BIT specifies the least significant bit of the Shift Register. N specifies the length of the Shift Register and the direction of the shift (Shift Plus = N, Shift Minus = -N).

Each bit shifted out by the SHRB instruction is placed in the overflow memory bit (SM1.1).

This instruction is defined by both the least significant bit (S_BIT) and the number of bits specified by the length (N).

Error conditions that set ENO = 0

- 0006 (indirect address)
- 0091 (operand out of range)
- 0092 (error in count field)

SM bits affected:

- SM1.1 (overflow)

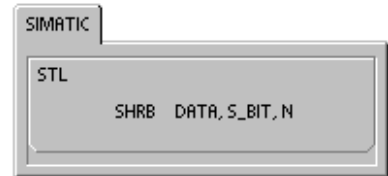
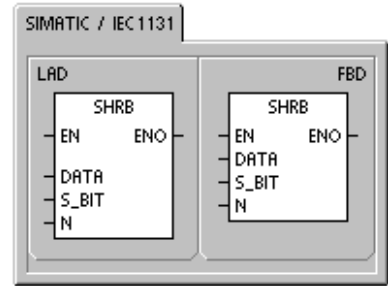

Table 6-59 Valid Operands for the Shift Register Bit Instruction

Inputs/Outputs	Data Types	Operands
DATA, S_Bit	BOOL	I, Q, V, M, SM, S, T, C, L
N	BYTE	IB, QB, VB, MB, SMB, SB, LB, AC, *VD, *LD, *AC, Constant

Use the following equation to compute the address of the most significant bit of the Shift Register (MSB.b):

$$\text{MSB.b} = \lceil (\text{Byte of } S_BIT) + ((N) - 1 + (\text{bit of } S_BIT)) / 8 \rceil \lceil \text{remainder of the division by } 8 \rceil$$

For example: if S_BIT is V33.4 and N is 14, the following calculation shows that the MSB.b is V35.1.

$$\begin{aligned} \text{MSB.b} &= V33 + ((14) - 1 + 4) / 8 \\ &= V33 + 17 / 8 \\ &= V33 + 2 \text{ with a remainder of } 1 \\ &= V35.1 \end{aligned}$$

On a Shift Minus, indicated by a negative value of length (N), the input data shifts into the most significant bit of the Shift Register, and shifts out of the least significant bit (S_BIT). The data shifted out is then placed in the overflow memory bit (SM1.1).

On a Shift Plus, indicated by a positive value of length (N), the input data (DATA) shifts into the least significant bit of the Shift Register, specified by the S_BIT, and out of the most significant bit of the Shift Register. The data shifted out is then placed in the overflow memory bit (SM1.1).

The maximum length of the shift register is 64 bits, positive or negative. Figure 6-35 shows bit shifting for negative and positive values of N.

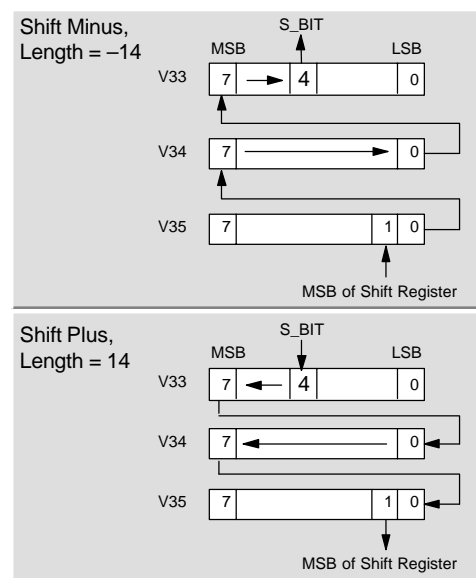
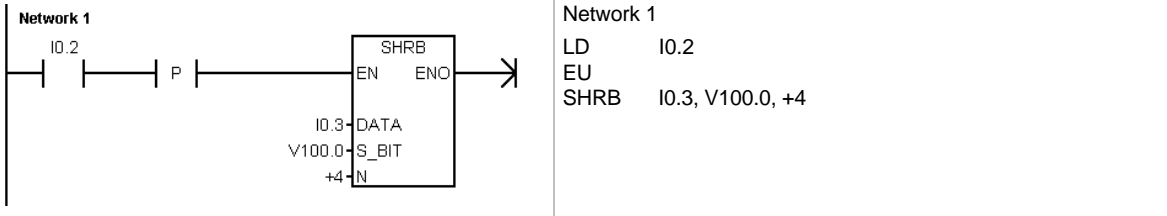
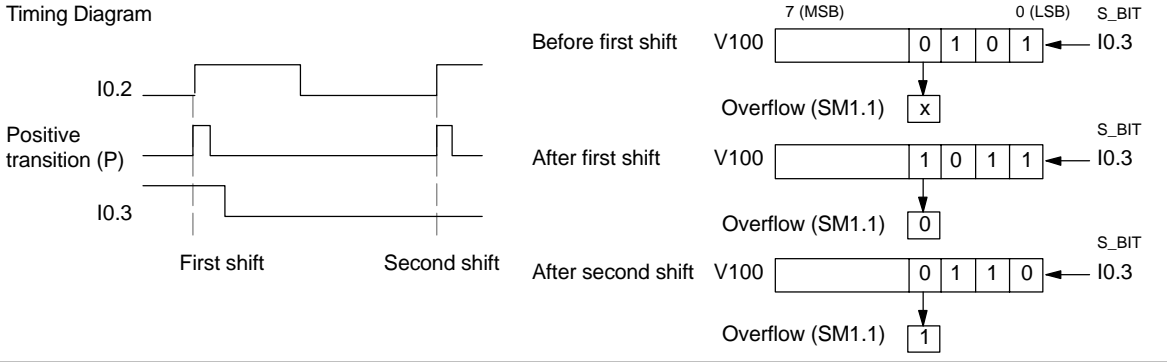

Figure 6-35 Shift Register Entry and Exit

Example: Shift Register Bit Instruction



Timing Diagram



6

Swap Bytes Instruction

The Swap Bytes instruction exchanges the most significant byte with the least significant byte of the word IN.

Error conditions that set ENO = 0

- 0006 (indirect address)

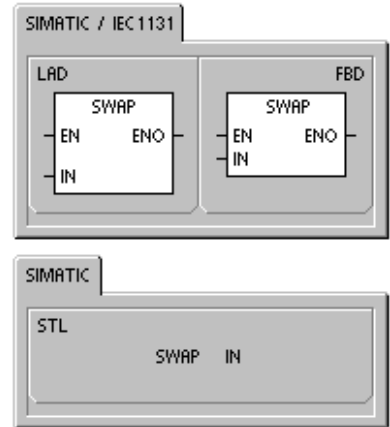
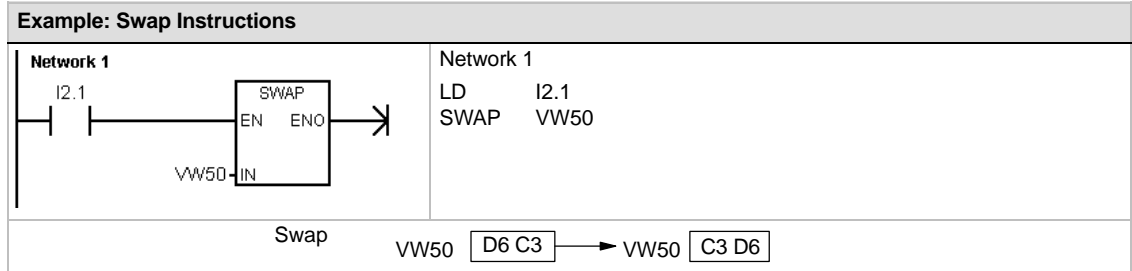

Table 6-60 Valid Operands for the Swap Bytes Instruction

Inputs/Outputs	Data Types	Operands
IN	WORD	IW, QW, VW, MW, SMW, SW, T, C, LW, AC, *VD, *LD, *AC



String Instructions

String Length

The String Length instruction (SLEN) returns the length of the string specified by IN.

Copy String

The Copy String instruction (SCPY) copies the string specified by IN to the string specified by OUT.

Concatenate String

The Concatenate String instruction (SCAT) appends the string specified by IN to the end of the string specified by OUT.

SM Bits and ENO

For the String Length, Copy String, and Concatenate String instructions, the following conditions affect ENO.

Error conditions that set ENO = 0

- 0006 (indirect address)
- 0091 (range error)

Table 6-61 Valid Operands for the String Length Instruction

Inputs/Outputs	Data Types	Operands
IN	BYTE (String)	VB, LB, *VD, *LD, *AC
OUT	BYTE	IB, QB, VB, MB, SMB, SB, LB, AC, *VD, *LD, *AC

Table 6-62 Valid Operands for the Copy String and Concatenate String Instructions

Inputs/Outputs	Data Types	Operands
IN, OUT	BYTE (String)	VB, LB, *VD, *LD, *AC

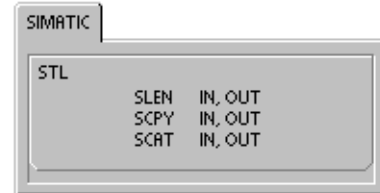
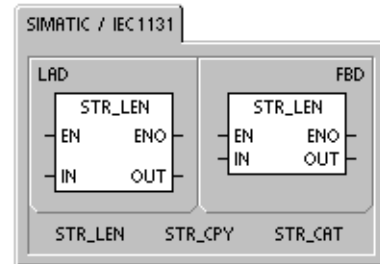

Example: Concatenate String, Copy String, and String Length Instructions

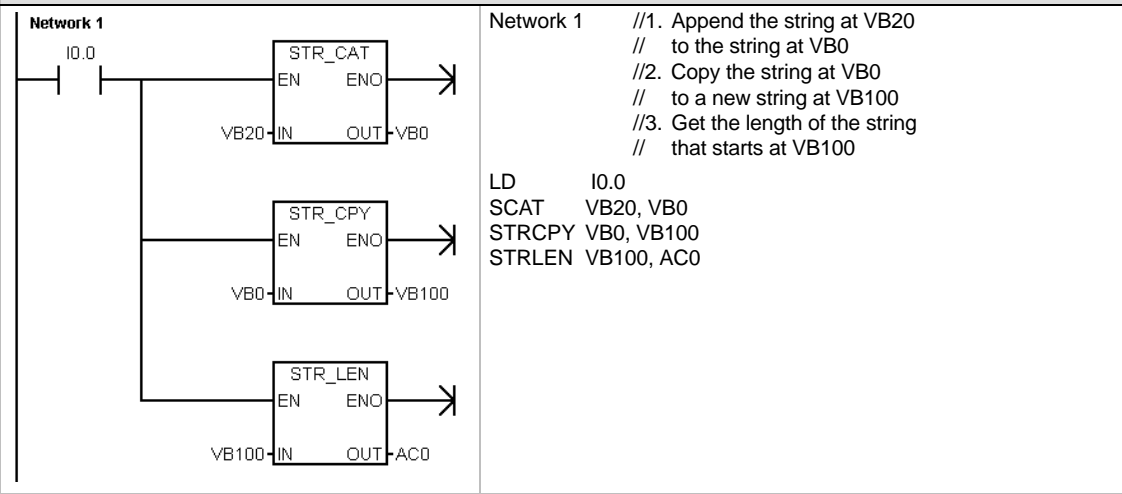

```

Network 1 //1. Append the string at VB20
           // to the string at VB0
           //2. Copy the string at VB0
           // to a new string at VB100
           //3. Get the length of the string
           // that starts at VB100
    
```

```

LD      I0.0
SCAT   VB20, VB0
STRCPY VB0, VB100
STRLEN VB100, AC0
    
```

Before executing the program

VB0						VB6	
6	'H'	'E'	'L'	'L'	'O'	' '	' '

VB20					VB25	
5	'W'	'O'	'R'	'L'	'D'	

After executing the program

VB0											VB11	
11	'H'	'E'	'L'	'L'	'O'	' '	' '	'W'	'O'	'R'	'L'	'D'

VB100											VB111	
11	'H'	'E'	'L'	'L'	'O'	' '	' '	'W'	'O'	'R'	'L'	'D'

AC0
11

Copy Substring from String

The Copy Substring from String instruction (SSCPY) copies the specified number of characters N from the string specified by IN, starting at the index INDX, to a new string specified by OUT.

Error conditions that set ENO = 0

- 0006 (indirect address)
- 0091 (range error)
- 009B (index=0)

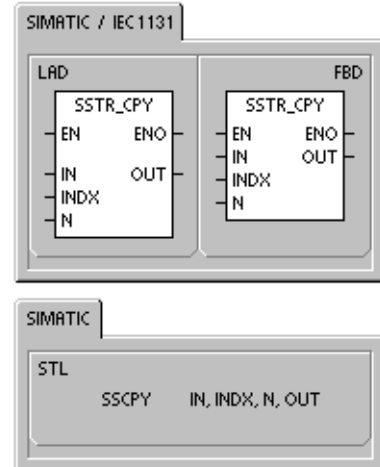

Table 6-63 Valid Operands for the Copy Substring from String Instructions

Inputs/Outputs	Data Types	Operands
IN, OUT	BYTE (String)	VB, LB, *VD, *LD, *AC
INDX, N	BYTE	IB, QB, VB, MB, SMB, SB, LB, AC, *VD, *LD, *AC, Constant

Example: Copy Substring Instruction

Network 1

Network 1 //Starting at the seventh character in the string at VB0, //copy 5 characters to a new string at VB20

```
LD I0.0
SSCPY VB0, 7, 5, VB20
```

Before executing the program

VB0	'H'	'E'	'L'	'L'	'O'	' '	'W'	'O'	'R'	'L'	'D'
-----	-----	-----	-----	-----	-----	-----	-----	-----	-----	-----	-----

After executing the program

VB20	5	'W'	'O'	'R'	'L'	'D'
------	---	-----	-----	-----	-----	-----

Find String Within String

The Find String Within String instruction (SFND) searches for the first occurrence of the string IN2 within the string IN1. The search begins at the starting position specified by OUT. If a sequence of characters is found that matches exactly the string IN2, the position of the first character in the sequence for the string is written to OUT. If the string IN2 was not found in the string IN1, the instruction OUT is set to 0.

Error conditions that set ENO = 0

- 0006 (indirect address)
- 0091 (range error)
- 009B (index=0)

Find First Character Within String

The Find First Character Within String instruction (CFND) searches the string IN1 for the first occurrence of any character from the character set described in the string IN2. The search begins at starting position OUT. If a matching character is found, the position of the character is written to OUT. If no matching character is found, OUT is set to 0.

Error conditions that set ENO = 0

- 0006 (indirect address)
- 0091 (range error)
- 009B (index=0)

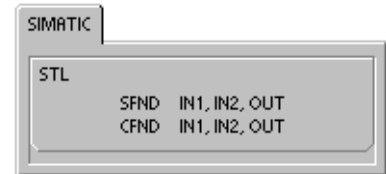
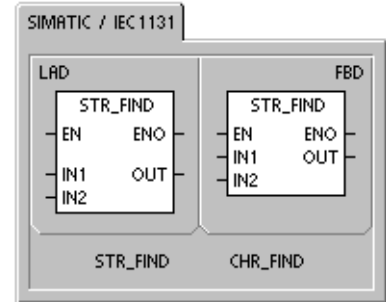
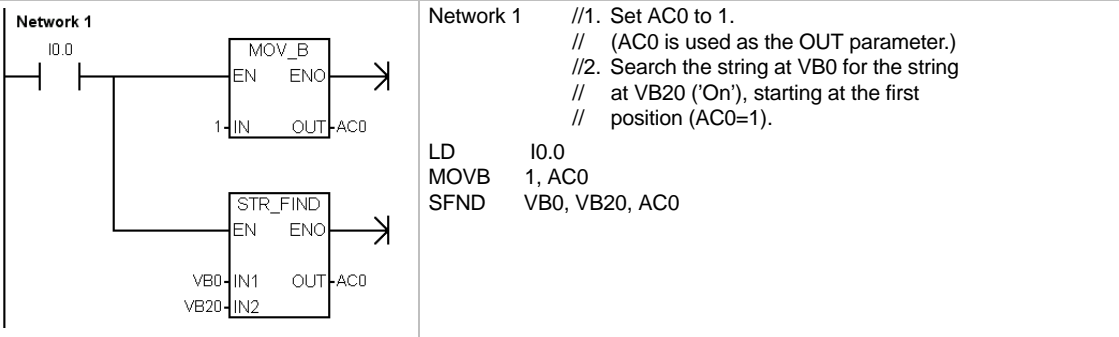

Table 6-64 Valid Operands for Find String Within String and Find First Character Within String Instructions

Inputs/Outputs	Data Types	Operands
IN1, IN2	BYTE (String)	VB, LB, *VD, *LD, *AC
OUT	BYTE	IB, QB, VB, MB, SMB, SB, LB, AC, *VD, *LD, *AC

Example: Find String Within String Instruction

The following example uses a string stored at VB0 as a command for turning a pump on or off. A string 'On' is stored at VB20, and a string 'Off' is stored at VB30. The result of the Find String Within String instruction is stored in AC0 (the OUT parameter). If the result is not 0, then the string 'On' was found in the command string (VB12).



```

Network 1 //1. Set AC0 to 1.
           // (AC0 is used as the OUT parameter.)
           //2. Search the string at VB0 for the string
           // at VB20 ('On'), starting at the first
           // position (AC0=1).
LD      I0.0
MOV_B   1, AC0
SFND   VB0, VB20, AC0
    
```

VB0												VB12		
12	'T'	'u'	'r'	'n'	' '	'P'	'u'	'm'	'p'	' '	'O'	'n'		
VB20				VB22		VB30			VB33					
2	'O'	'n'			3	'O'	'f'	'f'						

If the string in VB20 is found: AC0

If the string in VB20 is not found: AC0

Example: Find Character Within String Instruction

In the following example, a string stored at VB0 contains the temperature. The string at VB20 stores all the numeric characters (and the + and -) that can identify a temperature in a string. The sample program finds the starting position for a number in that string and then converts the numeric characters into a real number. VD200 stores the real-number value of the temperature.

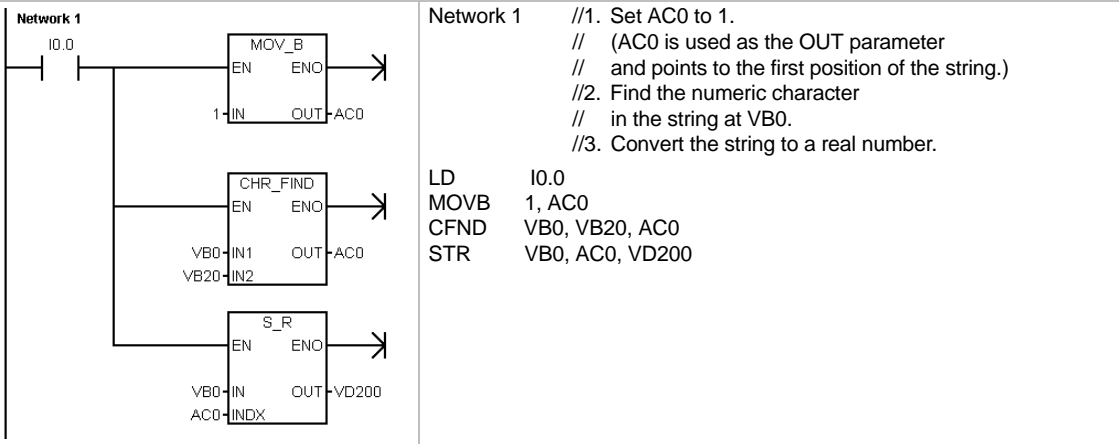

```

Network 1 //1. Set AC0 to 1.
           // (AC0 is used as the OUT parameter
           // and points to the first position of the string.)
           //2. Find the numeric character
           // in the string at VB0.
           //3. Convert the string to a real number.
LD      I0.0
MOV_B   1, AC0
CFND   VB0, VB20, AC0
STR    VB0, AC0, VD200
    
```

VB0											VB11			
11	'T'	'e'	'm'	'p'	' '	' '	'g'	'8'	'.'	'6'	'F'			
VB20												VB32		
12	'1'	'2'	'3'	'4'	'5'	'6'	'7'	'8'	'9'	'0'	'+'	'-'		

Starting position of the temperature stored in VB0: AC0

Real-number value of the temperature: VD200

Table Instructions

Add To Table

The Add To Table instruction adds word values (DATA) to a table (TBL). The first value of the table is the maximum table length (TL). The second value is the entry count (EC), which specifies the number of entries in the table. New data are added to the table after the last entry. Each time new data are added to the table, the entry count is incremented.

A table can have up to 100 data entries.

Error conditions that set ENO = 0

- SM1.4 (table overflow)
- 0006 (indirect address)
- 0091 (operand out of range)

SM bits affected:

- SM1.4 is set to 1 if you try to overfill the table

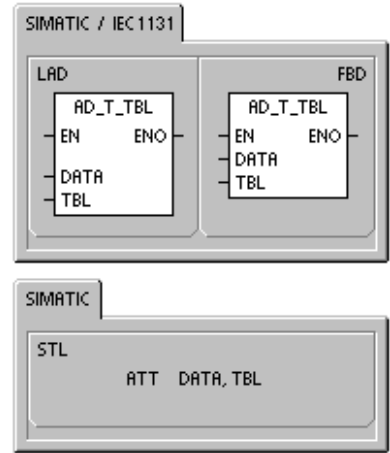

6

Table 6-65 Valid Operands for the Table Instructions

Inputs/Outputs	Data Types	Operands
DATA	INT	IW, QW, VW, MW, SMW, SW, T, C, LW, AC, AIW, *VD, *LD, *AC, Constant
TBL	WORD	IW, QW, VW, MW, SMW, SW, T, C, LW, *VD, *LD, *AC

Example: Add to Table Instruction

Network 1

Network 2

Network 1 //Load maximum table length

```
LD SM0.1
MOVW +6, VW200
```

Network 2

```
LD IO.0
ATT VW100, VW200
```

Before execution of ATT	After execution of ATT																																										
<table style="border-collapse: collapse;"> <tr><td style="border: 1px solid black; padding: 2px;">VW100</td><td style="border: 1px solid black; padding: 2px; text-align: center;">1234</td></tr> <tr><td style="border: 1px solid black; padding: 2px;">VW200</td><td style="border: 1px solid black; padding: 2px; text-align: center;">0006</td></tr> <tr><td style="border: 1px solid black; padding: 2px;">VW202</td><td style="border: 1px solid black; padding: 2px; text-align: center;">0002</td></tr> <tr><td style="border: 1px solid black; padding: 2px;">VW204</td><td style="border: 1px solid black; padding: 2px; text-align: center;">5431</td></tr> <tr><td style="border: 1px solid black; padding: 2px;">VW206</td><td style="border: 1px solid black; padding: 2px; text-align: center;">8942</td></tr> <tr><td style="border: 1px solid black; padding: 2px;">VW208</td><td style="border: 1px solid black; padding: 2px; text-align: center;">xxxx</td></tr> <tr><td style="border: 1px solid black; padding: 2px;">VW210</td><td style="border: 1px solid black; padding: 2px; text-align: center;">xxxx</td></tr> <tr><td style="border: 1px solid black; padding: 2px;">VW212</td><td style="border: 1px solid black; padding: 2px; text-align: center;">xxxx</td></tr> <tr><td style="border: 1px solid black; padding: 2px;">VW214</td><td style="border: 1px solid black; padding: 2px; text-align: center;">xxxx</td></tr> </table>	VW100	1234	VW200	0006	VW202	0002	VW204	5431	VW206	8942	VW208	xxxx	VW210	xxxx	VW212	xxxx	VW214	xxxx	<table style="border-collapse: collapse;"> <tr><td style="border: 1px solid black; padding: 2px;">VW200</td><td style="border: 1px solid black; padding: 2px; text-align: center;">0006</td><td style="padding-left: 10px;">TL (max. no. of entries)</td></tr> <tr><td style="border: 1px solid black; padding: 2px;">VW202</td><td style="border: 1px solid black; padding: 2px; text-align: center;">0003</td><td style="padding-left: 10px;">EC (entry count)</td></tr> <tr><td style="border: 1px solid black; padding: 2px;">VW204</td><td style="border: 1px solid black; padding: 2px; text-align: center;">5431</td><td style="padding-left: 10px;">d0 (data 0)</td></tr> <tr><td style="border: 1px solid black; padding: 2px;">VW206</td><td style="border: 1px solid black; padding: 2px; text-align: center;">8942</td><td style="padding-left: 10px;">d1 (data 1)</td></tr> <tr><td style="border: 1px solid black; padding: 2px;">VW208</td><td style="border: 1px solid black; padding: 2px; text-align: center;">1234</td><td style="padding-left: 10px;">d2 (data 2)</td></tr> <tr><td style="border: 1px solid black; padding: 2px;">VW210</td><td style="border: 1px solid black; padding: 2px; text-align: center;">xxxx</td><td></td></tr> <tr><td style="border: 1px solid black; padding: 2px;">VW212</td><td style="border: 1px solid black; padding: 2px; text-align: center;">xxxx</td><td></td></tr> <tr><td style="border: 1px solid black; padding: 2px;">VW214</td><td style="border: 1px solid black; padding: 2px; text-align: center;">xxxx</td><td></td></tr> </table>	VW200	0006	TL (max. no. of entries)	VW202	0003	EC (entry count)	VW204	5431	d0 (data 0)	VW206	8942	d1 (data 1)	VW208	1234	d2 (data 2)	VW210	xxxx		VW212	xxxx		VW214	xxxx	
VW100	1234																																										
VW200	0006																																										
VW202	0002																																										
VW204	5431																																										
VW206	8942																																										
VW208	xxxx																																										
VW210	xxxx																																										
VW212	xxxx																																										
VW214	xxxx																																										
VW200	0006	TL (max. no. of entries)																																									
VW202	0003	EC (entry count)																																									
VW204	5431	d0 (data 0)																																									
VW206	8942	d1 (data 1)																																									
VW208	1234	d2 (data 2)																																									
VW210	xxxx																																										
VW212	xxxx																																										
VW214	xxxx																																										

First-In-First-Out and Last-In-First-Out

A table can have up to 100 data entries.

First-In-First-Out

The First-In-First-Out instruction (FIFO) moves the oldest (or first) entry in a table to the output memory address by removing the first entry in the table (TBL) and moving the value to the location specified by DATA. All other entries of the table are shifted up one location. The entry count in the table is decremented for each instruction execution.

Last-In-First-Out

The Last-In-First-Out instruction (LIFO) moves the newest (or last) entry in the table to the output memory address by removing the last entry in the table (TBL) and moving the value to the location specified by DATA. The entry count in the table is decremented for each instruction execution.

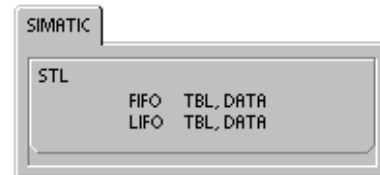
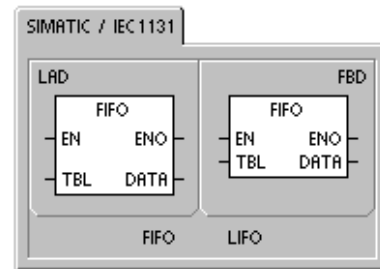

Error conditions that set ENO = 0

- SM1.5 (empty table)
- 0006 (indirect address)
- 0091 (operand out of range)

SM bits affected:

- SM1.5 is set to 1 if you try to remove an entry from an empty table

Table 6-66 Valid Operands for the First-In-First-Out and Last-In-First-Out Instructions

Inputs/Outputs	Data Types	Operands
TBL	WORD	IW, QW, VW, MW, SMW, SW, T, C, LW, *VD, *LD, *AC
DATA	INT	IW, QW, VW, MW, SMW, SW, T, C, LW, AC, AQW, *VD, *LD, *AC

Example: First-In-First-Out Instruction

Network 1

Network 1

```
LD    I4.1
FIFO  VW200, VW400
```

Before execution of FIFO

VW200	0006	TL (max. no. of entries)
VW202	0003	EC (entry count)
VW204	5431	d0 (data 0)
VW206	8942	d1 (data 1)
VW208	1234	d2 (data 2)
VW210	xxxx	
VW212	xxxx	
VW214	xxxx	

After execution of FIFO

VW200	0006	TL (max. no. of entries)
VW202	0002	EC (entry count)
VW204	8942	d0 (data 0)
VW206	1234	d1 (data 1)
VW208	xxxx	
VW210	xxxx	
VW212	xxxx	
VW214	xxxx	

VW400 5431

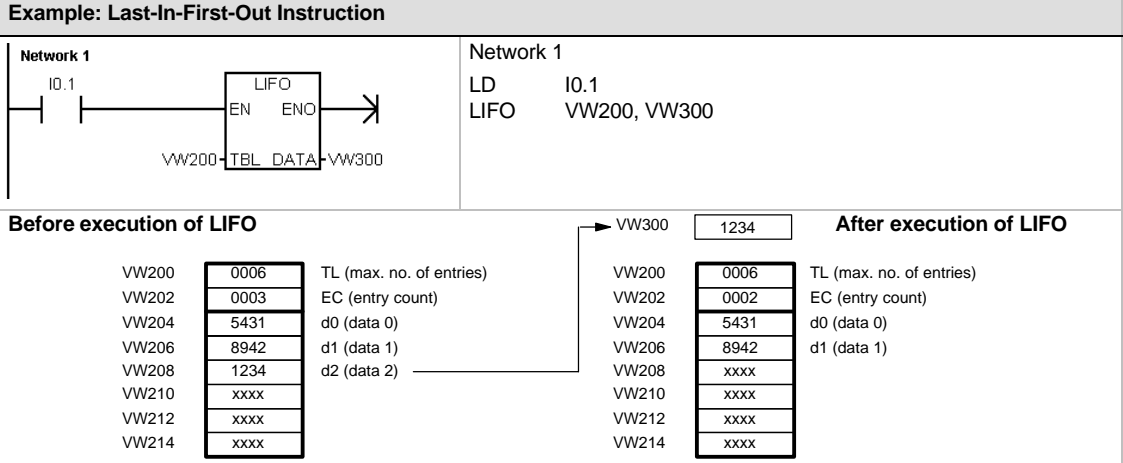

Memory Fill

The Memory Fill instruction (FILL) writes N consecutive words, beginning at address OUT, with the word value contained in address IN.

N has a range of 1 to 255.

Error conditions that set ENO = 0

- 0006 (indirect address)
- 0091 (operand out of range)

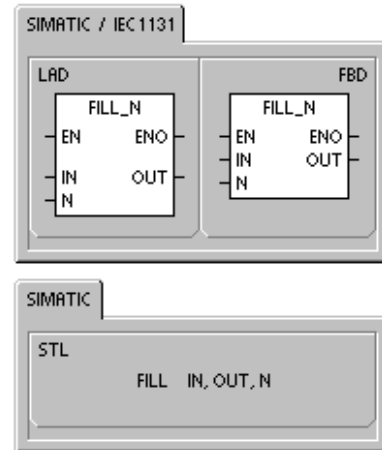

Table 6-67 Valid Operands for the Memory Fill Instruction

Inputs/Outputs	Data Types	Operands
IN	INT	IW, QW, VW, MW, SMW, SW, T, C, LW, AC, AIW, *VD, *LD, *AC, Constant
N	BYTE	IB, QB, VB, MB, SMB, SB, LB, AC, *VD, *LD, *AC, Constant
OUT	INT	IW, QW, VW, MW, SMW, SW, T, C, LW, AQW, *VD, *LD, *AC

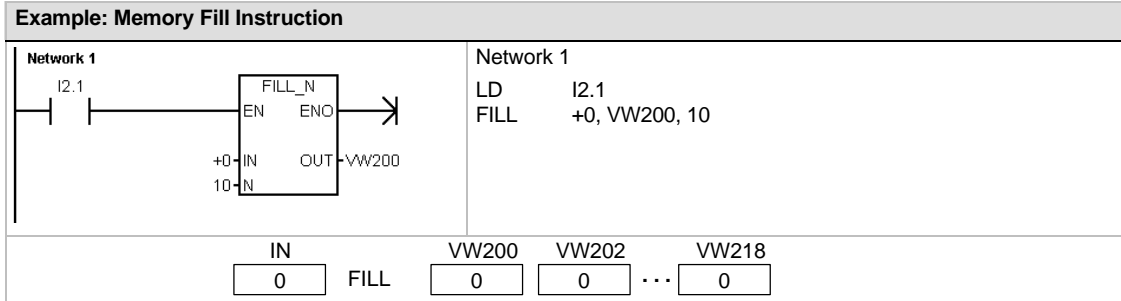

Table Find

The Table Find instruction (FND) searches a table for data that matches certain criteria. The Table Find instruction searches the table TBL, starting with the table entry INDX, for the data value or pattern PTN that matches the search criteria defined by CMD. The command parameter CMD is given a numeric value of 1 to 4 that corresponds to =, <>, <, and >, respectively.

If a match is found, the INDX points to the matching entry in the table. To find the next matching entry, the INDX must be incremented before invoking the Table Find instruction again. If a match is not found, the INDX has a value equal to the entry count.

A table can have up to 100 data entries. The data entries (area to be searched) are numbered from 0 to a maximum value of 99.

Error conditions that set ENO = 0

- 0006 (indirect address)
- 0091 (operand out of range)

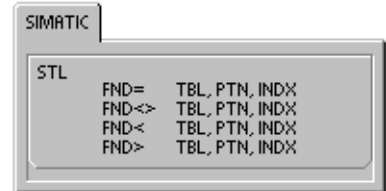
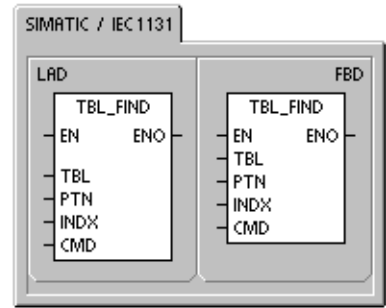

Table 6-68 Valid Operands for the Table Find Instruction

Inputs/Outputs	Data Types	Operands
TBL	WORD	IW, QW, VW, MW, SMW, T, C, LW, *VD, *LD, *AC
PTN	INT	IW, QW, VW, MW, SMW, SW, T, C, LW, AC, AIW, *VD, *LD, *AC, Constant
INDX	WORD	IW, QW, VW, MW, SMW, SW, T, C, LW, AC, *VD, *LD, *AC
CMD	BYTE	(Constant) 1: Equal (=), 2: Not Equal (<>), 3: Less Than (<), 4: Greater Than (>)



Tip

When you use the Table Find instruction with tables generated with the Add to Table, Last-In-First-Out, and First-In-First-Out instructions, the entry count and the data entries correspond directly. The maximum-number-of-entries word required for the Add to Table, Last-In-First-Out, or First-In-First-Out instructions is not required by the Table Find instruction. See Figure 6-36.

Consequently, you should set the TBL operand of a Find instruction to one-word address (two bytes) higher than the TBL operand of a corresponding the Add to Table, Last-In-First-Out, or First-In-First-Out instruction.

Table format for ATT, LIFO, and FIFO

VW200	0006	TL (max. no. of entries)
VW202	0006	EC (entry count)
VW204	xxxx	d0 (data 0)
VW206	xxxx	d1 (data 1)
VW208	xxxx	d2 (data 2)
VW210	xxxx	d3 (data 3)
VW212	xxxx	d4 (data 4)
VW214	xxxx	d5 (data 5)

Table format for TBL_FIND

VW202	0006	EC (entry count)
VW204	xxxx	d0 (data 0)
VW206	xxxx	d1 (data 1)
VW208	xxxx	d2 (data 2)
VW210	xxxx	d3 (data 3)
VW212	xxxx	d4 (data 4)
VW214	xxxx	d5 (data 5)

Figure 6-36 Different Table Formats between the Table Find Instruction and the ATT, LIFO, and FIFO Instructions

Example: Table Find Instruction

Network 1

Network 1

```
LD I2.1
FND= VW202, 16#3130, AC1
```

When I2.1 is on, search the table for a value equal to 3130 HEX.

VW202	0006	EC (entry count)
VW204	3133	d0 (data 0)
VW206	4142	d1 (data 1)
VW208	3130	d2 (data 2)
VW210	3030	d3 (data 3)
VW212	3130	d4 (data 4)
VW214	4541	d5 (data 5)

If the table was created using ATT, LIFO, and FIFO instructions, VW200 contains the maximum number of allowed entries and is not required by the Find instructions.

AC1 AC1 must be set to 0 to search from the top of table.

Execute table search

AC1 AC1 contains the data entry number corresponding to the first match found in the table (d2).

AC1 Increment the INDX by one, before searching the remaining entries of the table.

Execute table search

AC1 AC1 contains the data entry number corresponding to the second match found in the table (d4).

AC1 Increment the INDX by one, before searching the remaining entries of the table.

Execute table search

AC1 AC1 contains a value equal to the entry count. The entire table has been searched without finding another match.

AC1 Before the table can be searched again, the INDX value must be reset to 0.

Example: Creating a Table

The following program creates a table with 20 entries. The first memory location of the table contains the length of the table (in this case 20 entries). The second memory location shows the current number of table entries. The other locations contain the entries. A table can have up to 100 entries. It does not include the parameters defining the maximum length of the table or the actual number of entries (here VW0 and VW2). The actual number of entries in the table (here VW2) is automatically incremented or decremented by the CPU with every command.

Before you work with a table, assign the maximum number of table entries. Otherwise, you cannot make entries in the table. Also, be sure that all read and write commands are activated with edges.

To search the table, the index (VW106) must set to 0 before doing the find. If a match is found, the index will have the table entry number, but if no match is found, the index will match the current entry count for the table (VW2).

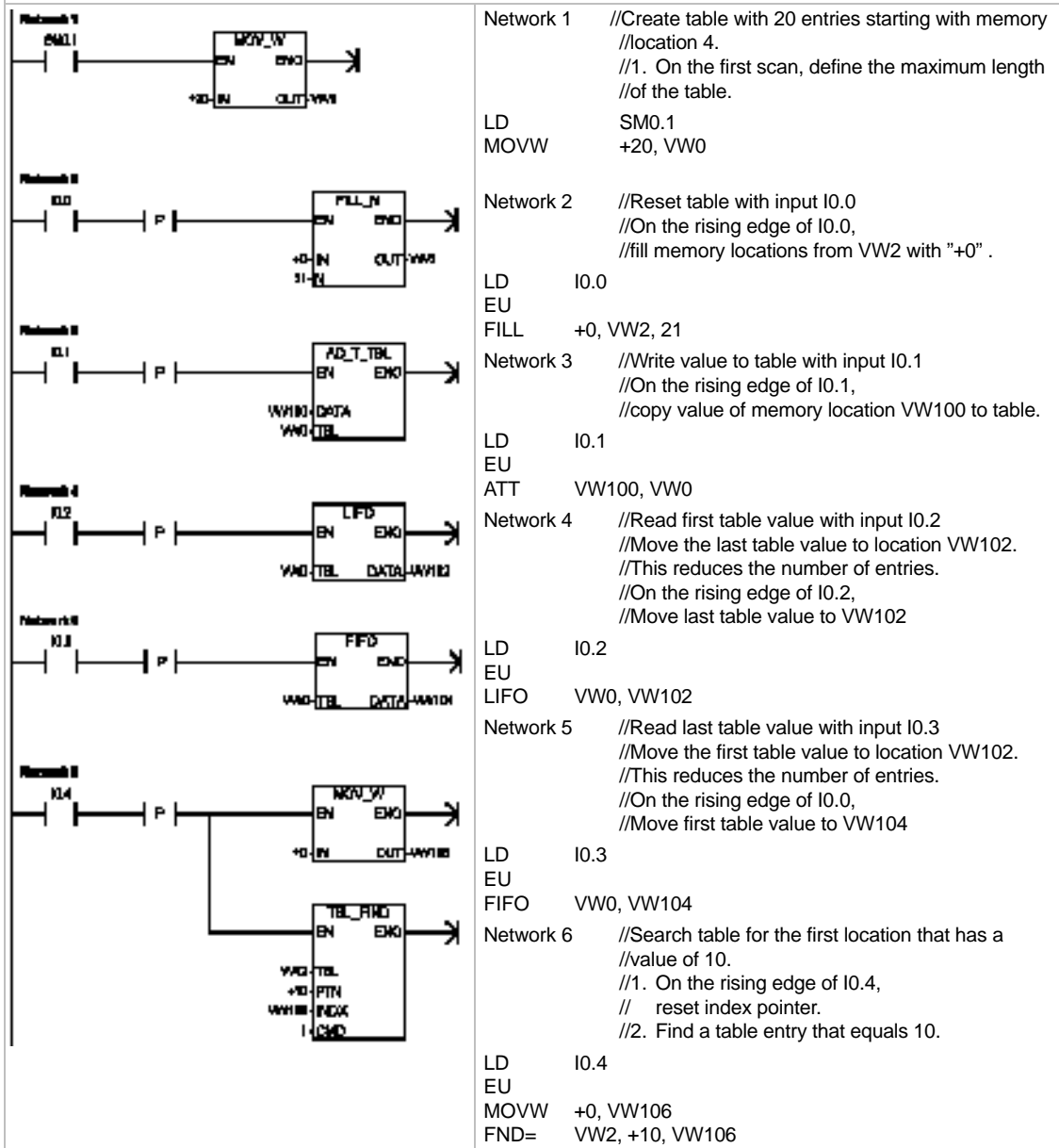

Timer Instructions

SIMATIC Timer Instructions

On-Delay Timer

Retentive On-Delay Timer

The On-Delay Timer (TON) and Retentive On-Delay Timer (TONR) instructions count time when the enabling input is on. The timer number (Txx) determines the resolution of the timer.

Off-Delay Timer

The Off-Delay Timer (TOF) is used to delay turning an output off for a fixed period of time after the input turns off. The timer number (Txx) determines the resolution of the timer.

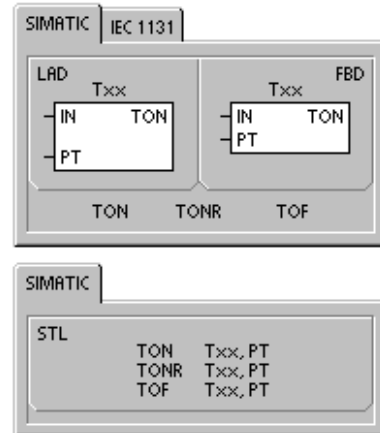

Table 6-69 Valid Operands for the SIMATIC Timer Instructions

Inputs/Outputs	Data Types	Operands
Txx	WORD	Constant (T0 to T255)
IN	BOOL	I, Q, V, M, SM, S, T, C, L, Power Flow
PT	INT	IW, QW, VW, MW, SMW, SW, T, C, LW, AC, AIW, *VD, *LD, *AC, Constant



Tip

You cannot share the same timer number (Txx) for an off-delay timer (TOF) and an on-delay timer (TON). For example, you cannot have both a TON T32 and a TOF T32.

As shown in Table 6-70, the three types of timers perform different types of timing tasks:

- You can use a TON for timing a single interval.
- You can use a TONR for accumulating a number of timed intervals.
- You can use a TOF for extending time past an off (or false) condition, such as for cooling a motor after it is turned off.

Table 6-70 Operations of the Timer Instructions

Type	Current >= Preset	State of the Enabling Input (IN)	Power Cycle/First Scan
TON	Timer bit on Current continues counting to 32,767	ON: Current value counts time OFF: Timer bit off, current value = 0	Timer bit off Current value = 0
TONR	Timer bit on Current continues counting to 32,767	ON: Current value counts time OFF: Timer bit and current value maintain last state	Timer bit off Current value can be maintained ¹
TOF	Timer bit off Current = Preset, stops counting	ON: Timer bit on, current value = 0 OFF: Timer counts after on-to-off transition	Timer bit off Current value = 0

¹ The retentive timer current value can be selected for retention through a power cycle. See Chapter 4 for information about memory retention for the S7-200 CPU.



Tips and Tricks

Refer to the *Tips and Tricks on the documentation CD* for a sample program that uses the on-delay timer (TON). See *Tip 31*

The TON and TONR instructions count time when the enabling input is on. When the current value is equal to or greater than the preset time, the timer bit is on.

- The current value of a TON timer is cleared when the enabling input is off, whereas the current value of the TONR timer is maintained when the input is off.
- You can use the TONR timer to accumulate time when the input turns on and off. Use the Reset instruction (R) to clear the current value of the TONR.
- Both the TON and the TONR timers continue counting after the preset is reached, and they stop counting at the maximum value of 32,767.

The TOF instruction is used to delay turning an output off for a fixed period of time after the input turns off. When the enabling input turns on, the timer bit turns on immediately, and the current value is set to 0. When the input turns off, the timer counts until the elapsed time reaches the preset time.

- When the preset is reached, the timer bit turns off and the current value stops incrementing; however, if the input turns on again before the TOF reaches the preset value, the timer bit remains on.
- The enabling input must make an on-to-off transition for the TOF to begin counting time intervals.
- If the TOF timer is inside an SCR region and the SCR region is inactive, then the current value is set to 0, the timer bit is turned off, and the current value does not increment.



Tip

You can reset a TONR only by using the Reset (R) instruction. You can also use the Reset instruction to reset any TON or TOF. The Reset instruction performs the following operations:

- Timer Bit = off
- Timer Current = 0

After a reset, TOF timers require the enabling input to make the transition from on to off in order for the timer to restart.

Determining the Resolution of the Timer

Timers count time intervals. The resolution (or time base) of the timer determines the amount of time in each interval. For example, a TON with a resolution of 10 ms counts the number of 10-ms intervals that elapse after the TON is enabled: a count of 50 on a 10-ms timer represents 500 ms. The SIMATIC timers are available in three resolutions: 1 ms, 10 ms, and 100 ms. As shown in Table 6-71, the timer number determines the resolution of the timer.



Tip

To guarantee a minimum time interval, increase the preset value (PV) by 1. For example: To ensure a minimum timed interval of at least 2100 ms for a 100-ms timer, set the PV to 22.

Table 6-71 Timer Numbers and Resolutions

Timer Type	Resolution	Maximum Value	Timer Number
TONR (retentive)	1 ms	32.767 s (0.546 min.)	T0, T64
	10 ms	327.67 s (5.46 min.)	T1 to T4, T65 to T68
	100 ms	3276.7 s (54.6 min.)	T5 to T31, T69 to T95
TON, TOF (non-retentive)	1 ms	32.767 s (0.546 min.)	T32, T96
	10 ms	327.67 s (5.46 min.)	T33 to T36, T97 to T100
	100 ms	3276.7 s (54.6 min.)	T37 to T63, T101 to T255

Understanding How Resolution Affects the Timer Action

For a timer with a resolution of 1 ms, the timer bit and the current value are updated asynchronous to the scan cycle. For scans greater than 1 ms, the timer bit and the current value are updated multiple times throughout the scan.

For a timer with a resolution of 10 ms, the timer bit and the current value are updated at the beginning of each scan cycle. The timer bit and current value remain constant throughout the scan, and the time intervals that accumulate during the scan are added to the current value at the start of each scan.

For a timer with a resolution of 100 ms, the timer bit and current value are updated when the instruction is executed; therefore, ensure that your program executes the instruction for a 100-ms timer only once per scan cycle in order for the timer to maintain the correct timing.

Example: SIMATIC On-Delay Timer

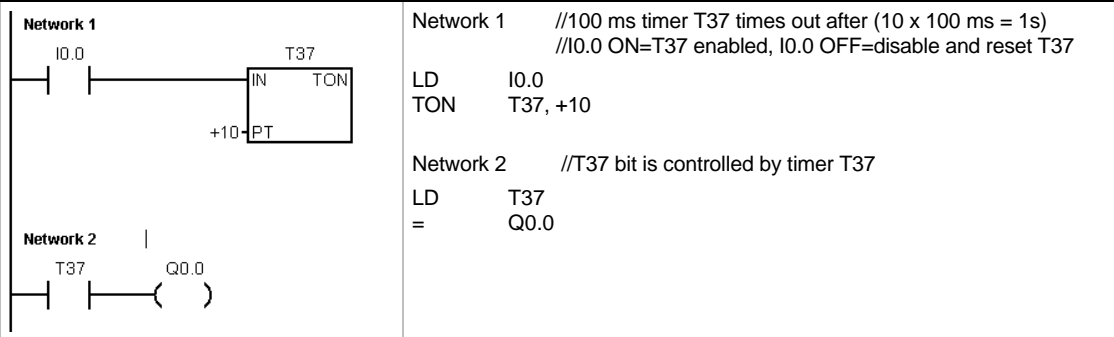

Timing Diagram

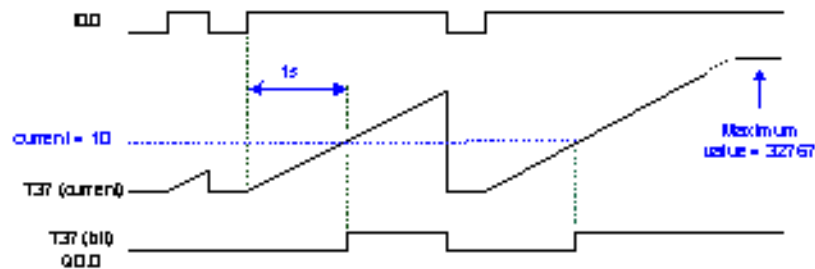



Tip

To guarantee that the output of a self-resetting timer is turned on for one scan each time the timer reaches the preset value, use a normally closed contact instead of the timer bit as the enabling input to the timer.

Example: SIMATIC Self-Resetting On-Delay Timer

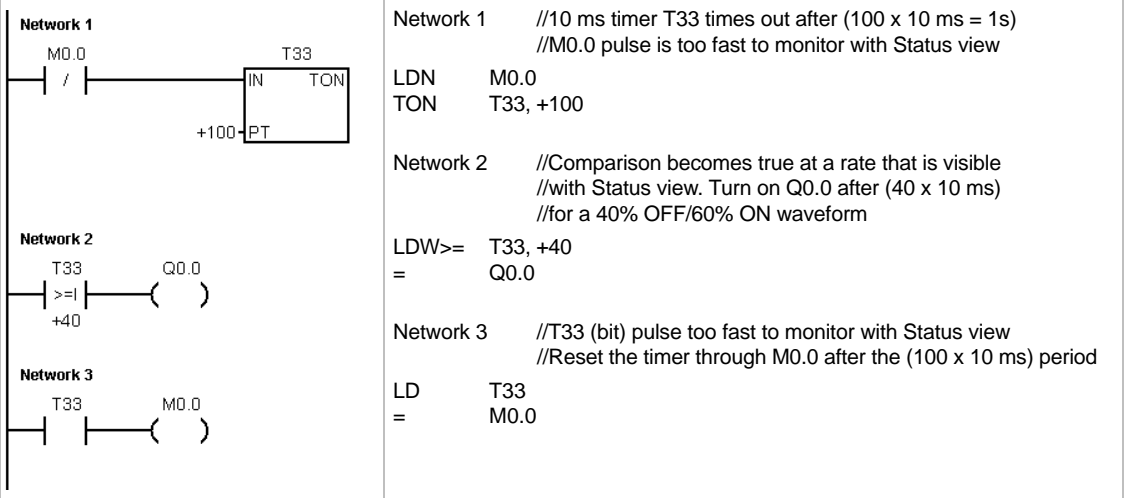

Timing Diagram

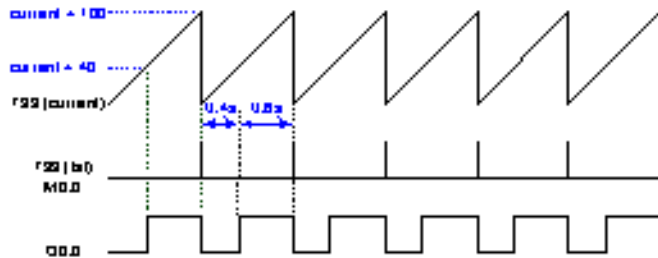

Example: SIMATIC Off-Delay Timer

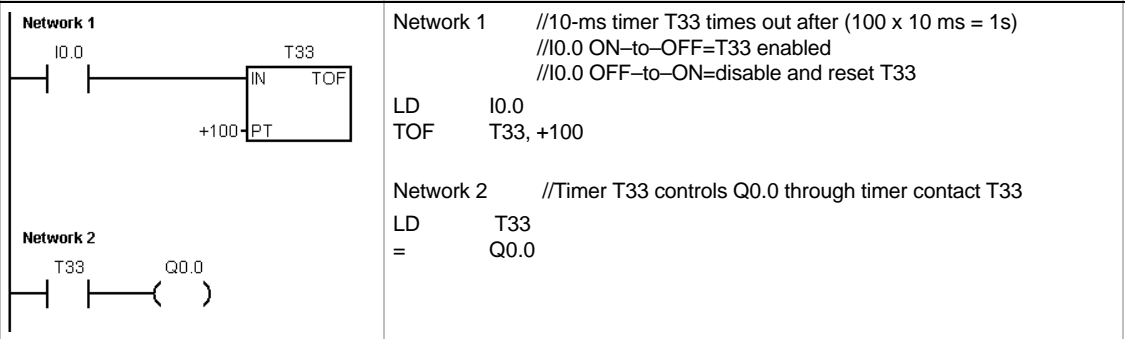

Timing Diagram

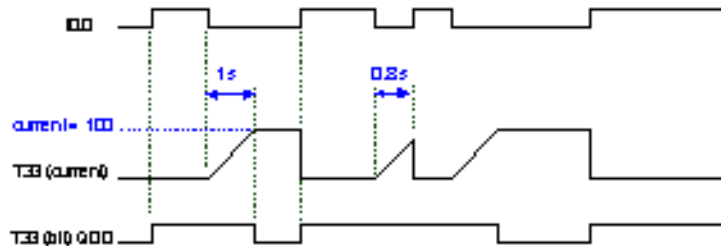

6

Example: SIMATIC Retentive On-Delay Timer

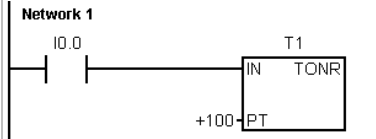
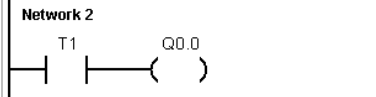
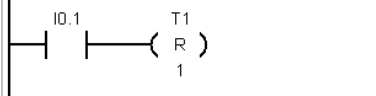
<p>Network 1</p>  <p>Network 2</p>  <p>Network 3</p> 	<p>Network 1 //10 ms TONR timer T1 times out at PT=(100 x 10 ms=1s) LD I0.0 TONR T1, +100</p> <p>Network 2 //T1 bit is controlled by timer T1. //Turns Q0.0 on after the timer accumulates a total //of 1 second LD T1 = Q0.0</p> <p>Network 3 //TONR timers must be reset by a Reset instruction //with a T address. //Resets timer T1 (current and bit) when I0.1 is on. LD I0.1 R T1, 1</p>
---	--

Timing Diagram

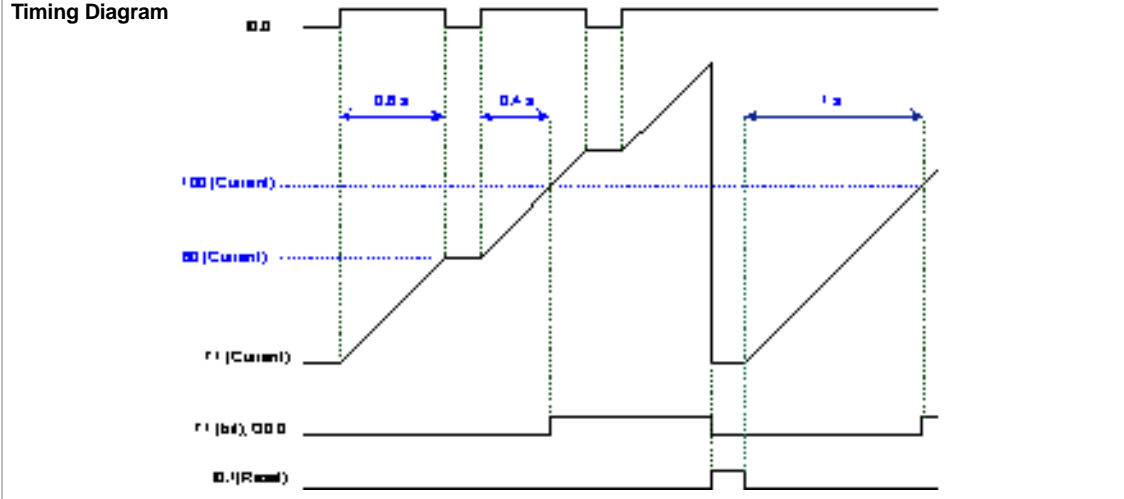

IEC Timer Instructions

On-Delay Timer

The On-Delay Timer (TON) instruction counts time when the enabling input is on.

Off-Delay Timer

The Off-Delay Timer (TOF) delays turning an output off for a fixed period of time after the input turns off.

Pulse Timer

The Pulse Timer (TP) generates pulses for a specific duration.

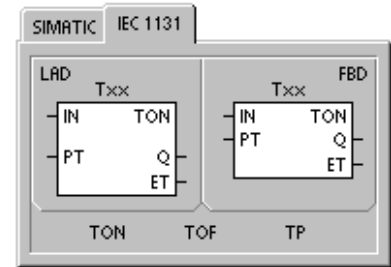

Table 6-72 Valid Operands for the IEC Timer Instructions

Inputs/Outputs	Data Types	Operands
Txx	TON, TOF, TP	Constant (T32 to T63, T96 to T255)
IN	BOOL	I, Q, V, M, SM, S, T, C, L, Power Flow
PT	INT	IW, QW, VW, MW, SMW, SW, LW, AC, AIW, *VD, *LD, *AC, Constant
Q	BOOL	I, Q, V, M, SM, S, L
ET	INT	IW, QW, VW, MW, SMW, SW, LW, AC, AQW, *VD, *LD, *AC



Tip

You cannot share the same timer numbers for TOF, TON, and TP. For example, you cannot have both a TON T32 and a TOF T32.

- The TON instruction counts time intervals up to the preset value when the enabling input (IN) becomes true. When the elapsed time (ET) is equal to the Preset Time (PT), the timer output bit (Q) turns on. The output bit resets when the enabling input turns off. When the preset is reached, timing stops and the timer is disabled.
- The TOF instruction delays setting an output to off for a fixed period of time after the input turns off. It times up to the preset value when the enabling input (IN) turns off. When the elapsed time (ET) is equal to the preset time (PT), the timer output bit (Q) turns off. When the preset is reached, the timer output bit turns off and the elapsed time is maintained until the enabling input makes the transition to on. If the enabling input sets the transition to off for a period of time shorter than the preset time, the output bit remains on.
- The TP instruction generates pulses for a specific duration. As the enabling input (IN) turns on, the output bit (Q) turns on. The output bit remains on for the pulse specified within the preset time (PT). When the elapsed time (ET) reaches preset (PT), the output bit turns off. The elapsed time is maintained until the enabling input turns off. When the output bit turns on, it remains on until the pulse time has elapsed.

Each count of the current value is a multiple of the time base. For example, a count of 50 on a 10-ms timer represents 500 ms. The IEC timers (TON, TOF, and TP) are available in three resolutions. The resolution is determined by the timer number, as shown in Table 6-73.

Table 6-73 Resolution of the IEC Timers

Resolution	Maximum Value	Timer Number
1 ms	32.767 s (0.546 minutes)	T32, T96
10 ms	327.67 s (5.46 minutes)	T33 to T36, T97 to T100
100 ms	3276.7 s (54.6 minutes)	T37 to T63, T101 to T255

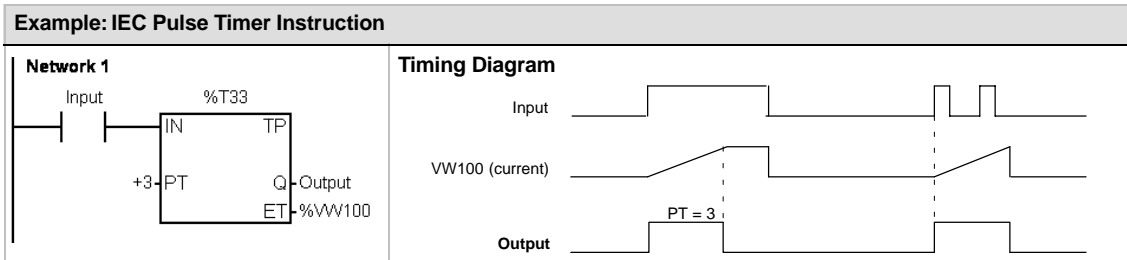
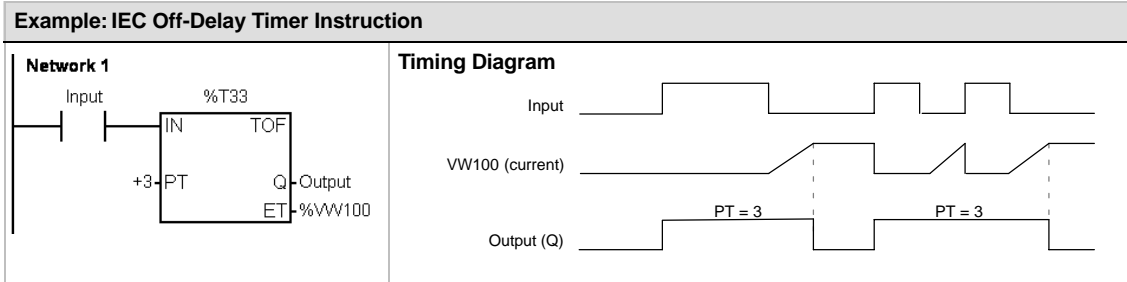
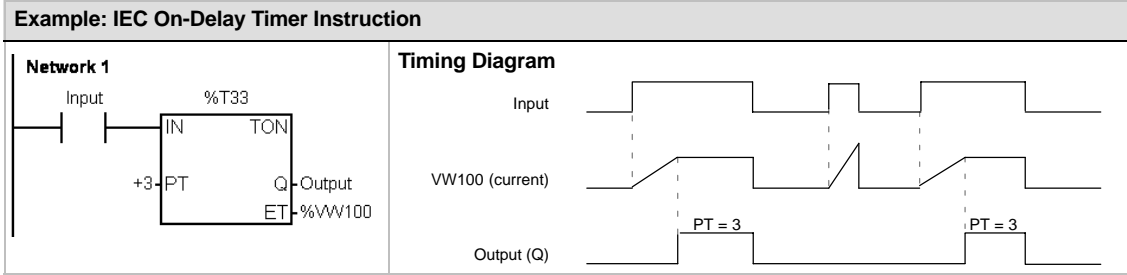

Subroutine Instructions

The Call Subroutine instruction (CALL) transfers control to the subroutine SBR_N. You can use a Call Subroutine instruction with or without parameters. After the subroutine completes its execution, control returns to the instruction that follows the Call Subroutine.

The Conditional Return from Subroutine instruction (CRET) terminates the subroutine based upon the preceding logic.

To add a subroutine, select the **Edit > Insert > Subroutine** menu command.

Error conditions that set ENO = 0

- 0008 (maximum subroutine nesting exceeded)
- 0006 (indirect address)

From the main program, you can nest subroutines (place a subroutine call within a subroutine) to a depth of eight. From an interrupt routine, you cannot nest subroutines.

A subroutine call cannot be placed in any subroutine called from an interrupt routine. Recursion (a subroutine that calls itself) is not prohibited, but you should use caution when using recursion with subroutines.

Table 6-74 Valid Operands for the Subroutine Instructions

Inputs/Outputs	Data Types	Operands
SBR_N	WORD	Constant for CPU 221, CPU 222, CPU 224, and CPU 226: 0 to 63 for CPU 226XM: 0 to 127



Tip

STEP 7–Micro/WIN automatically adds an unconditional return from each subroutine.

When a subroutine is called, the entire logic stack is saved, the top of stack is set to one, all other stack locations are set to zero, and control is transferred to the called subroutine. When this subroutine is completed, the stack is restored with the values saved at the point of call, and control is returned to the calling routine.

Accumulators are common to subroutines and the calling routine. No save or restore operation is performed on accumulators due to subroutine use.

Calling a Subroutine With Parameters

Subroutines can contain passed parameters. The parameters are defined in the local variable table of the subroutine. The parameters must have a symbol name (maximum of 23 characters), a variable type, and a data type. Sixteen parameters can be passed to or from a subroutine.

The variable type field in the local variable table defines whether the variable is passed into the subroutine (IN), passed into and out of the subroutine (IN_OUT), or passed out of the subroutine (OUT). Table 6-75 describes the parameter types for a subroutine. To add a parameter entry, place the cursor on the variable type field of the type (IN, IN_OUT, or OUT) that you want to add. Click the right mouse button to get a menu of options. Select the Insert option and then the Row Below option. Another parameter entry of the selected type appears below the current entry.

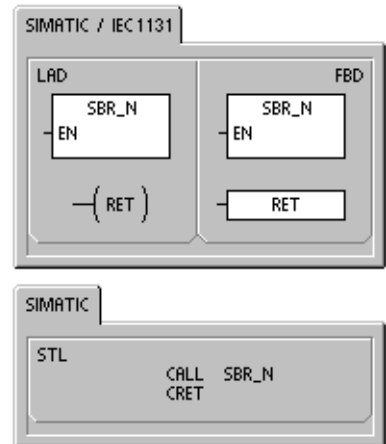

Table 6-75 Parameter Types for a Subroutine

Parameter	Description
IN	Parameters are passed into the subroutine. If the parameter is a direct address (such as VB10), the value at the specified location is passed into the subroutine. If the parameter is an indirect address (such as *AC1), the value at the location pointed to is passed into the subroutine. If the parameter is a data constant (16#1234) or an address (&VB100), the constant or address value is passed into the subroutine.
IN_OUT	The value at the specified parameter location is passed into the subroutine, and the result value from the subroutine is returned to the same location. Constants (such as 16#1234) and addresses (such as &VB100) are not allowed for input/output parameters.
OUT	The result value from the subroutine is returned to the specified parameter location. Constants (such as 16#1234) and addresses (such as &VB100) are not allowed as output parameters.
TEMP	Any local memory that is not used for passed parameters can be used for temporary storage within the subroutine.

As shown in Figure 6-37, the data type field in the local variable table defines the size and format of the parameter. The parameter types are listed below:

- BOOL:** This data type is used for single bit inputs and outputs. IN3 in the following example is a Boolean input.
- BYTE, WORD, DWORD:** These data types identify an unsigned input or output parameter of 1, 2, or 4 bytes, respectively.
- INT, DINT:** These data types identify signed input or output parameters of 2 or 4 bytes, respectively.

Name	Var Type	Data Type	Comment
EN	Bool	BOOL	
Piece	Bool	BOOL	Piece piece flag
Addr	Byte	BYTE	Address of slave device
Data	Int	INT	Data to write to slave
Status	In_Out	BYTE	Status of slave
Done	Bool	BOOL	Done flag
Error	Word	WORD	Error number if any

Figure 6-37 Local Variable Table

- REAL:** This data type identifies a single precision (4 byte) IEEE floating-point value.
- Power Flow:** Boolean power flow is allowed only for bit (Boolean) inputs. This declaration tells STEP 7-Micro/WIN that this input parameter is the result of power flow based on a combination of bit logic instructions. Boolean power flow inputs must appear first in the local variable table before any other type input. Only input parameters are allowed to be used this way. The enable input (EN) and the IN1 inputs in the following example use Boolean logic.

Example: Subroutine Call

There are two STL examples provided. The first set of STL instructions can be displayed only in the STL editor since the BOOL parameters used as power flow inputs are not saved to L memory.

The second set of STL instructions can be displayed also in the LAD and FBD editors because L memory is used to save the state of the BOOL inputs parameters that are shown as power flow inputs in LAD and FBD.

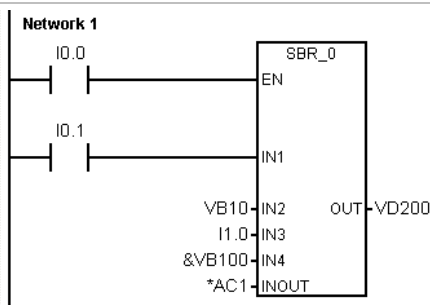

STL only:

```

Network 1
LD    IO.0
CALL  SBR_0, IO.1, VB10, I1.0, &VB100, *AC1, VD200
    
```

To display correctly in LAD and FBD:

```

Network 1
LD    I0.0
=     L60.0
LD    I0.1
=     L63.7
LD    L60.0
CALL  SBR_0, L63.7, VB10, I1.0, &VB100, *AC1, VD200
    
```

Address parameters such as IN4 (&VB100) are passed into a subroutine as a DWORD (unsigned double word) value. The type of a constant parameter must be specified for the parameter in the calling routine with a constant descriptor in front of the constant value. For example, to pass an unsigned double word constant with a value of 12,345 as a parameter, the constant parameter must be specified as DW#12345. If the constant descriptor is omitted from the parameter, the constant can be assumed to be a different type.

There are no automatic data type conversions performed on the input or output parameters. For example, if the local variable table specifies that a parameter has the data type REAL, and in the calling routine a double word (DWORD) is specified for that parameter, the value in the subroutine will be a double word.

When values are passed to a subroutine, they are placed into the local memory of the subroutine. The left-most column of the local variable table shows the local memory address for each passed parameter. Input parameter values are copied to the subroutine's local memory when the subroutine is called. Output parameter values are copied from the subroutine's local memory to the specified output parameter addresses when the subroutine execution is complete.

The data element size and type are represented in the coding of the parameters. Assignment of parameter values to local memory in the subroutine is as follows:

- Parameter values are assigned to local memory in the order specified by the call subroutine instruction with parameters starting at L.0.
- One to eight consecutive bit parameter values are assigned to a single byte starting with Lx.0 and continuing to Lx.7.
- Byte, word, and double word values are assigned to local memory on byte boundaries (LBx, LWx, or LDx).

In the Call Subroutine instruction with parameters, parameters must be arranged in order with input parameters first, followed by input/output parameters, and then followed by output parameters.

If you are programming in STL, the format of the CALL instruction is:

CALL subroutine number, parameter 1, parameter 2, ... , parameter

Example: Subroutine and Return from Subroutine Instructions		
M A I N	<p>Network 1</p>	<p>Network 1 //On the first scan, call subroutine 0 for initialization.</p> <pre>LD SM0.1 CALL SBR_0</pre>
S B R O	<p>Network 1</p> <p>Network 2</p>	<p>Network 1 //You can use a conditional return to leave //the subroutine before the last network.</p> <pre>LD M14.3 CRET</pre> <p>Network 2 //This network will be skipped if M14.3 is on.</p> <pre>LD SM0.0 MOVB 10, VB0</pre>

Communicating over a Network

7

The S7-200 is designed to solve your communications and networking needs by supporting not only the simplest of networks but also supporting more complex networks. The S7-200 also provides tools that allow you to communicate with other devices, such as printers and weigh scales which use their own communications protocols.

STEP 7–Micro/WIN makes setting up and configuring your network simple and straightforward.

In This Chapter

Understanding the Basics of S7-200 Network Communications	208
Selecting the Communications Protocol for Your Network	211
Installing and Removing Communications Interfaces	216
Building Your Network	218
Creating User-Defined Protocols with Freeport Mode	222
Using Modems and STEP 7–Micro/WIN with Your Network	224
Advanced Topics	228

Understanding the Basics of S7-200 Network Communications

Using Master and Slave Devices on a Network

The S7-200 supports a master-slave network and can function as either a master or a slave in a network, while STEP 7–Micro/WIN is always a master.



Tip

If you use Windows NT and a PC/PPI cable, no other master can be present on the network.

Masters

A device that is a master on a network can initiate a request to another device on the network. A master can also respond to requests from other masters on the network. Typical master devices include STEP 7–Micro/WIN, human-machine interface devices such as a TD 200, and S7-300 or S7-400 PLCs. The S7-200 functions as a master when it is requesting information from another S7-200 (peer-to-peer communications).



Tip

A TP070 will not work on a network with another master device.

Slaves

A device that is configured as a slave can only respond to requests from a master device; a slave never initiates a request. For most networks, the S7-200 functions as a slave. As a slave device, the S7-200 responds to requests from a network master device, such as an operator panel or STEP 7–Micro/WIN.

Setting the Baud Rate and Network Address

The speed that data is transmitted across the network is the baud rate, which is typically measured in units of kilobaud (kbaud) or megabaud (Mbaud). The baud rate measures how much data can be transmitted within a given amount of time. For example, a baud rate of 19.2 kbaud describes a transmission rate of 19,200 bits per second.

Every device that communicates over a given network must be configured to transmit data at the same baud rate. Therefore, the fastest baud rate for the network is determined by the slowest device connected to the network.

Table 7-1 lists the baud rates supported by the S7-200.

Table 7-1 Baud Rates Supported by the S7-200

Network	Baud Rate
Standard Network	9.6 kbaud to 187.5 kbaud
Using an EM 277	9.6 kbaud to 12 Mbaud
Freeport Mode	1200 baud to 115.2 kbaud

The network address is a unique number that you assign to each device on the network. The unique network address ensures that the data is transferred to or retrieved from the correct device. The S7-200 supports network addresses from 0 to 126. For an S7-200 with two ports, each port can have a network address. Table 7-2 lists the default (factory) settings for the S7-200 devices.

Table 7-2 Default Addresses for S7-200 Devices

S7-200 Device	Default Address
STEP 7–Micro/WIN	0
HMI (TD 200, TP, or OP)	1
S7-200 CPU	2

Setting the Baud Rate and Network Address for STEP 7–Micro/WIN

You must configure the baud rate and network address for STEP 7–Micro/WIN. The baud rate must be the same as the other devices on the network, and the network address must be unique.

Typically, you do not change the network address (0) for STEP 7–Micro/WIN. If your network includes another programming package, such as STEP 7, then you might need to change the network address for STEP 7–Micro/WIN.

As shown in Figure 7-1, configuring the baud rate and network address for STEP 7–Micro/WIN is simple. After you click the Communications icon in the Navigation bar, you perform the following steps:

1. Double-click the icon in the Communications Setup window.
2. Click the Properties button on the Set PG/PC Interface dialog box.
3. Select the network address for STEP 7–Micro/WIN.
4. Select the baud rate for STEP 7–Micro/WIN.

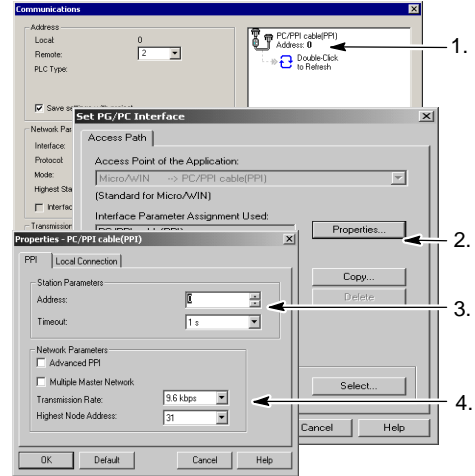

Figure 7-1 Configuring STEP 7–Micro/WIN

Setting the Baud Rate and Network Address for the S7-200

You must also configure the baud rate and network address for the S7-200. The system block of the S7-200 stores the baud rate and network address. After you select the parameters for the S7-200, you must download the system block to the S7-200.

The default baud rate for each S7-200 port is 9.6 kbaud, and the default network address is 2.

As shown in Figure 7-2, use STEP 7–Micro/WIN to set the baud rate and network address for the S7-200. After you select the System Block icon in the Navigation bar or select the **View > Component > System Block** menu command, you perform the following steps:

1. Select the network address for the S7-200.
2. Select the baud rate for the S7-200.
3. Download the system block to the S7-200.

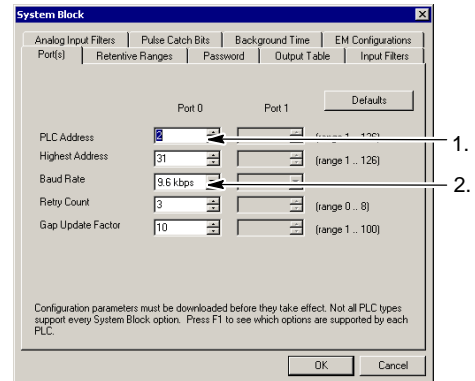

Figure 7-2 Configuring the S7-200 CPU

Setting the Remote Address

Before you can download the updated settings to the S7-200, you must set both the communications (COM) port of STEP 7–Micro/WIN and the remote address of the S7-200 to match the current setting of the remote S7-200. See Figure 7-3.

After you download the updated settings, you must reconfigure the COM port (if different from the setting used to download the settings for the remote S7-200). To display the Communications dialog box, either click the Communications icon in the Navigation bar or select the **View > Component > Communications** menu command.

1. Select the remote address.
2. Ensure that the parameters (baud rate) for the COM port, the remote S7-200 port, and the PC/PPI cable match. Otherwise, the communications fail.

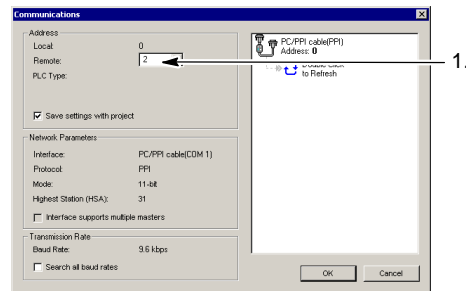

Figure 7-3 Configuring the S7-200 CPU

Searching for the S7-200 CPUs on a Network

You can search for and identify the S7-200 CPUs that are attached to your network. You can also search the network at a specific baud rate or at all baud rates when looking for S7-200s.

7

If you are using a PC/PPI cable, STEP 7–Micro/WIN can only search at 9.6 kbaud and 19.2 kbaud. For a CP card, STEP 7–Micro/WIN searches 9.6 kbaud, 19.2 kbaud and 187.5 kbaud. The search starts at the baud rate that is currently selected.

1. Open the Communications dialog box and double-click the Refresh icon to start the search.
2. To search all baud rates, select the Search All Baud Rates check box.

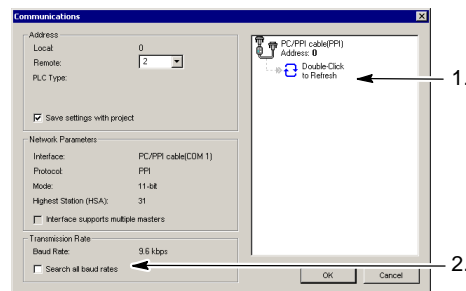

Figure 7-4 Searching for CPUs on a Network

Selecting the Communications Protocol for Your Network

The S7-200 CPUs support one or more of the following communications capabilities that allow you to configure your network for the performance and functionality that your application requires:

- Point-to-Point Interface (PPI)
- Multi-Point Interface (MPI)
- PROFIBUS

Based on the Open System Interconnection (OSI) seven-layer model of communications architecture, these protocols are implemented on a token ring network which conforms to the PROFIBUS standard as defined in the European Standard EN 50170. These protocols are asynchronous, character-based protocols with one start bit, eight data bits, even parity, and one stop bit. Communications frames depend upon special start and stop characters, source and destination station addresses, frame length, and a checksum for data integrity. The protocols can run on a network simultaneously without interfering with each other, as long as the baud rate is the same for each protocol.

PPI Protocol

PPI is a master-slave protocol: the master devices send requests to the slave devices, and the slave devices respond. See Figure 7-5. Slave devices do not initiate messages, but wait until a master sends them a request or polls them for a response.

Masters communicate to slaves by means of a shared connection which is managed by the PPI protocol. PPI does not limit the number of masters that can communicate with any one slave; however, you cannot install more than 32 masters on the network.

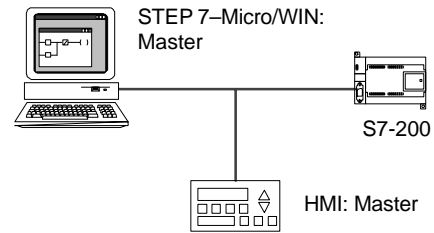

Figure 7-5 PPI Network

Selecting PPI Advanced allows network devices to establish a logical connection between the devices. With PPI Advanced, there are a limited number of connections supplied by each device. See Table 7-3 for the number of connections supported by the S7-200.

S7-200 CPUs can act as master devices while they are in RUN mode, if you enable PPI master mode in the user program. (See the description of SMB30 in Appendix D.) After enabling PPI master mode, you can use the Network Read or the Network Write instructions to read from or write to other S7-200s. While the S7-200 is acting as a PPI master, it still responds as a slave to requests from other masters.

You can use PPI protocol to communicate with all S7-200 CPUs. To communicate with an EM 277, you must enable PPI Advanced.

Table 7-3 Number of Connections for the S7-200 CPU and EM 277 Modules

Module	Baud Rate	Connections
S7-200 CPU	Port 0	9.6 kbaud, 19.2 kbaud, or 187.5 kbaud
	Port 1	9.6 kbaud, 19.2 kbaud, or 187.5 kbaud
EM 277 Module	9.6 kbaud to 12 Mbaud	6 per module

MPI Protocol

MPI allows both master-master and master-slave communications. See Figure 7-6. To communicate with an S7-200 CPU, STEP 7–Micro/WIN establishes a master–slave connection. MPI protocol does not communicate with an S7-200 CPU operating as a master.

Network devices communicate by means of separate connections (managed by the MPI protocol) between any two devices. Communication between devices is limited to the number of connections supported by the S7-200 CPU or EM 277 modules. See Table 7-3 for the number of connections supported by the S7-200.

For MPI protocol, the S7-300 and S7-400 PLCs use the XGET and XPUT instructions to read and write data to the S7-200 CPU. For information about these instructions, refer to your S7-300 or S7-400 programming manual.

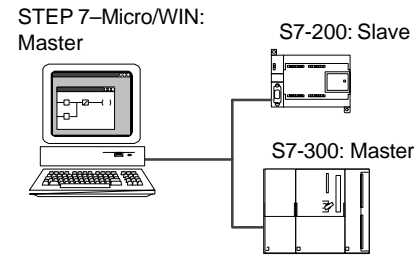

Figure 7-6 MPI Network

PROFIBUS Protocol

The PROFIBUS protocol is designed for high-speed communications with distributed I/O devices (remote I/O). There are many PROFIBUS devices available from a variety of manufacturers. These devices range from simple input or output modules to motor controllers and PLCs.

PROFIBUS networks typically have one master and several slave I/O devices. See Figure 7-7. The master device is configured to know what types of I/O slaves are connected and at what addresses. The master initializes the network and verifies that the slave devices on the network match the configuration. The master continuously writes output data to the slaves and reads input data from them.

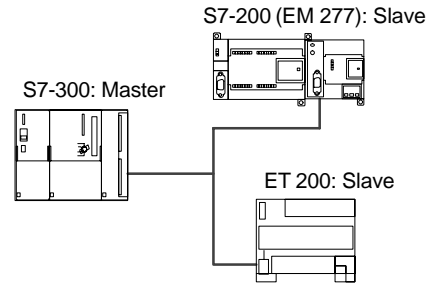

Figure 7-7 PROFIBUS Network

When a DP master configures a slave device successfully, it then owns that slave device. If there is a second master device on the network, it has very limited access to the slaves owned by the first master.

Sample Network Configurations Using Only S7-200 Devices

Single-Master PPI Networks

For a simple single-master network, the programming station and the S7-200 CPU are connected by either a PC/PPI cable or by a communications processor (CP) card installed in the programming station.

In the sample network at the top of Figure 7-8, the programming station (STEP 7–Micro/WIN) is the network master. In the sample network at the bottom of Figure 7-8, a human-machine interface (HMI) device (such as a TD 200, TP, or OP) is the network master.

In both sample networks, the S7-200 CPU is a slave that responds to requests from the master.

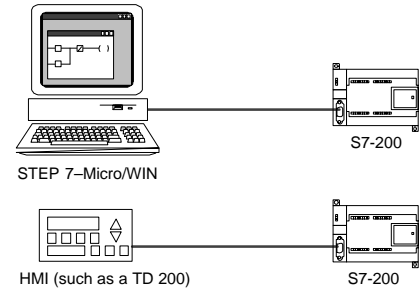

Figure 7-8 Single-Master PPI Network

For a single-master PPI configuration, you configure STEP 7–Micro/WIN to use PPI protocol: select either single-master, multi-master, or PPI Advanced.

Multi-Master PPI Networks

Figure 7-9 shows a sample network of multiple masters with one slave. The programming station (STEP 7–Micro/WIN) uses either a CP card or a PC/PPI cable, and STEP 7–Micro/WIN and the HMI device share the network.

Both STEP 7–Micro/WIN and the HMI device are masters and must have separate network addresses. The S7-200 CPU is a slave.

For a network with multiple masters accessing a single slave, you configure STEP 7–Micro/WIN to use PPI protocol with the multi-master driver enabled. PPI Advanced is optimal.

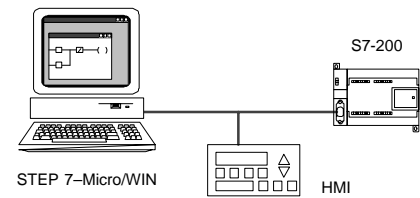

Figure 7-9 Multiple Masters with One Slave

Figure 7-10 shows a PPI network with multiple masters communicating with multiple slaves. In this example, both STEP 7–Micro/WIN and the HMI can request data from any S7-200 CPU slave. STEP 7–Micro/WIN and the HMI device share the network.

All devices (masters and slaves) have different network addresses.

For a PPI network with multiple masters and multiple slaves, you configure STEP 7–Micro/WIN to use PPI protocol with the multi-master driver enabled. PPI Advanced is optimal.

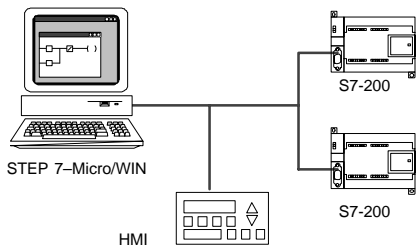

Figure 7-10 Multiple Masters and Slaves

Complex PPI Networks

Figure 7-11 shows a sample network that uses multiple masters with peer-to-peer communications.

STEP 7–Micro/WIN and the HMI device read and write over the network to the S7-200 CPUs, and the S7-200 CPUs use the Network Read and Network Write instructions to read and write to each other (peer-to-peer communications).

For this type of complex PPI network, you configure STEP 7–Micro/WIN to use PPI protocol with the multi-master driver enabled. PPI Advanced is optimal.

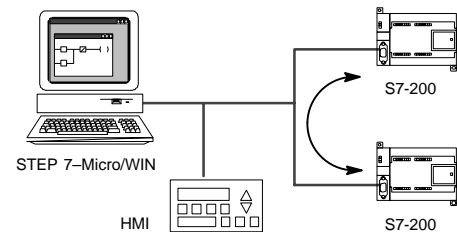

Figure 7-11 Peer-to-Peer Communications

Figure 7-12 shows another example of a complex PPI network that uses multiple masters with peer-to-peer communications. In this example, each HMI monitors one S7-200 CPU.

The S7-200 CPUs use the NETR and NETW instructions to read and write to each other (peer-to-peer communications).

For this network, you configure STEP 7–Micro/WIN to use PPI protocol with the multi-master driver enabled. PPI Advanced is optimal.

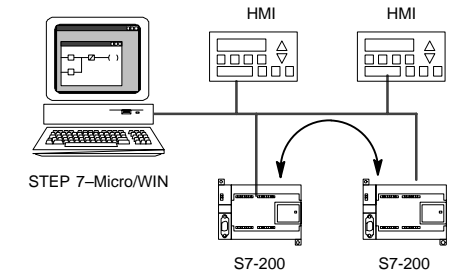

Figure 7-12 HMI Devices and Peer-to-Peer

Sample Network Configurations Using S7-200, S7-300, and S7-400 Devices

Networks with Baud Rates Up to 187.5 kbaud

In the sample network shown in Figure 7-13, the S7-300 uses the XPUT and XGET instructions to communicate with an S7-200 CPU. The S7-300 cannot communicate with an S7-200 CPU in master mode.

For baud rates above 19.2 kbaud, STEP 7–Micro/WIN must be connected by a communications processor (CP) card.

To communicate with the S7-200 CPUs, you configure STEP 7–Micro/WIN to use PPI protocol with the multi-master driver enabled. PPI Advanced is optimal.

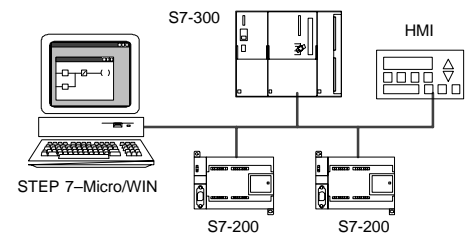

Figure 7-13 Baud Rates Up to 187.5 Kbaud

Networks with Baud Rates Above 187.5 kbaud (Up to 12 Mbaud)

For baud rates above 187.5 kbaud, the S7-200 CPU must use an EM 277 module for connecting to the network. See Figure 7-14. STEP 7–Micro/WIN must be connected by a communications processor (CP) card.

In this configuration, the S7-300 can communicate with the S7-200s, using the XPUT and XGET instructions, and the HMI can monitor either the S7-200s or the S7-300.

The EM 277 is always a slave device.

STEP 7–Micro/WIN can program or monitor either S7-200 CPU through the EM 277. To communicate with an EM 277, you configure STEP 7–Micro/WIN to use PPI protocol with the PPI Advanced driver enabled.

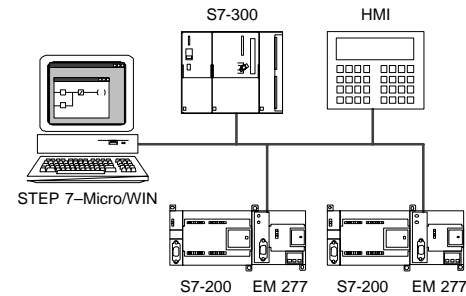

Figure 7-14 Baud Rates Above 187.5 Kbaud

Sample PROFIBUS-DP Network Configurations

Networks with S7-315-2 DP as PROFIBUS Master and EM 277 as PROFIBUS Slave

Figure 7-15 shows a sample PROFIBUS network that uses an S7-315-2 DP as the PROFIBUS master. An EM 277 module is a PROFIBUS slave.

The S7-315-2 DP can read data from or write data to the EM 277, from 1 byte up to 128 bytes. The S7-315-2 DP reads or writes V memory locations in the S7-200.

This network supports baud rates from 9600 baud to 12 Mbaud.

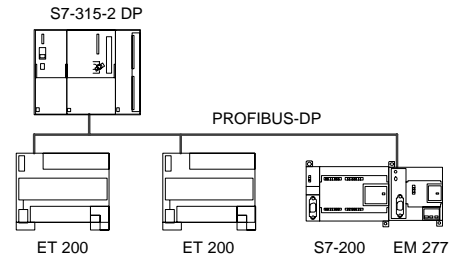

Figure 7-15 Network with S7-315-2 DP

Networks with STEP 7-Micro/WIN and HMI

Figure 7-16 shows a sample network with an S7-315-2 DP as the PROFIBUS master and EM 277 as a PROFIBUS slave. In this configuration, the HMI monitors the S7-200 through the EM 277. STEP 7-Micro/WIN programs the S7-200 through the EM 277.

This network supports baud rates from 9600 baud to 12 Mbaud. STEP 7-Micro/WIN requires a CP card for baud rates above 19.2 kbaud.

You configure STEP 7-Micro/WIN to use PROFIBUS protocol for the CP card. If there are only DP devices present on the network, select the DP or Standard profile. If there are non-DP devices on the network, then select the Universal (DP/FMS) profile for all PROFIBUS master devices.

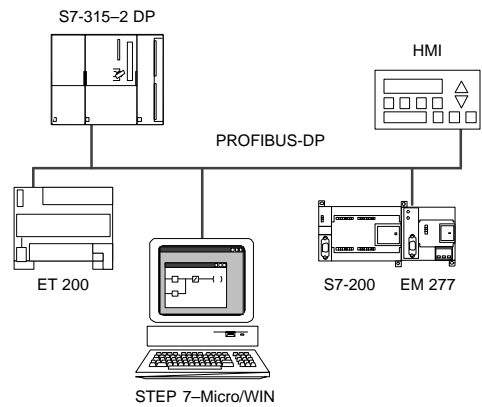

Figure 7-16 PROFIBUS Network

Installing and Removing Communications Interfaces

From the Set PG/PC Interface dialog box, you use the Installing/Uninstalling Interfaces dialog box to install or remove communications interfaces for your computer

1. In the Set PG/PC Interface dialog box, click Select to access the Installing/Uninstalling Interfaces dialog box.

The Selection box lists the interfaces that are available, and the Installed box displays the interfaces that have already been installed on your computer.

2. *To add a communications interface:* Select the communications hardware installed on your computer and click Install. When you close the Installing/Uninstalling Interfaces dialog box, the Set PG/PC Interface dialog box displays the interface in the Interface Parameter Assignment Used box.
3. *To remove a communications interface:* Select the interface to be removed and click Uninstall. When you close the Installing/Uninstalling Interfaces dialog box, the Set PG/PC Interface dialog box removes the interface from the Interface Parameter Assignment Used box.

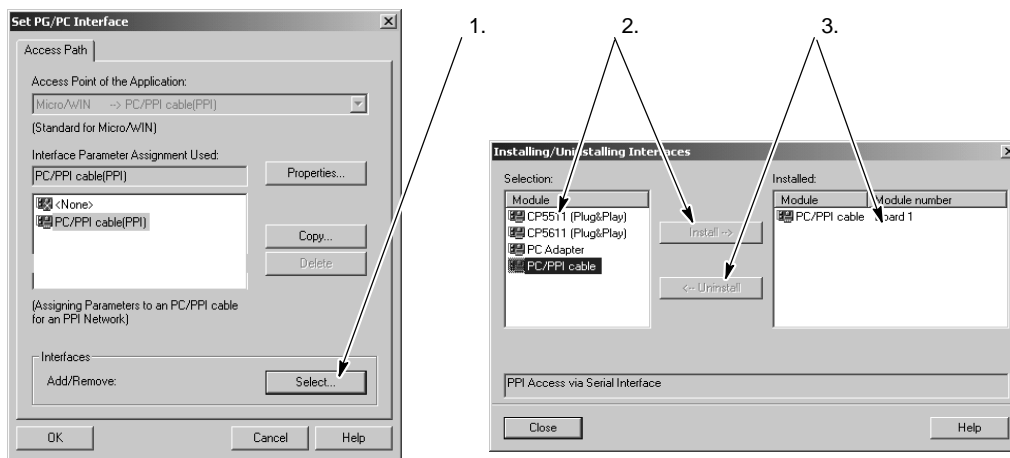

Figure 7-17 Set PG/PC Interface and Installing/Uninstalling Interfaces Dialog Boxes



Tip

Special Hardware Installation Information for Windows NT Users

Installing hardware modules under the Windows NT operating system is slightly different from installing hardware modules under Windows 95. Although the hardware modules are the same for either operating system, installation under Windows NT requires more knowledge of the hardware that you want to install. Windows 95 tries automatically to set up system resources for you, but Windows NT does not. Windows NT provides you with default values only. These values may or may not match the hardware configuration. These parameters can be modified easily to match the required system settings.

When you have installed a piece of hardware, select it from the Installed list box and click the Resources button. The Resources dialog box appears. The Resources dialog box allows you to modify the system settings for the actual piece of hardware that you installed. If this button is unavailable (gray), you do not need to do anything more.

At this point you may need to refer to your hardware manual to determine the setting for each of the parameters listed in the dialog box, depending on your hardware settings. You might need to try several different interrupts in order to establish communications correctly.

Adjusting the Port Settings of Your Computer for PPI Multi-Master

If you are using the PC/PPI cable with an operating system that supports the PPI Multi-Master configuration (Windows NT does not support the PPI Multi-Master), you might need to adjust the port settings on your computer:

1. Right-click the My Computer icon on the desktop and select the **Properties** menu command.
2. Select the Device Manager tab. For Windows 2000, select first the Hardware tab and then Device Manager button.
3. Double-click the Ports (COM & LPT).
4. Select the communications port that you are currently using (for example, COM1).
5. On the Port Settings tab, click the Advanced button.
6. Set the Receive Buffer and the Transmit Buffer controls to the lowest value (1).
7. Click OK to apply the change, close all the windows, and reboot the computer to make the new settings active.

Building Your Network

General Guidelines

Always install appropriate surge suppression devices for any wiring that could be subject to lightning surges.

Avoid placing low-voltage signal wires and communications cables in the same wire tray with AC wires and high-energy, rapidly switched DC wires. Always route wires in pairs, with the neutral or common wire paired with the hot or signal-carrying wire.

The communications port of the S7-200 CPU is not isolated. Consider using an RS-485 repeater or an EM 277 module to provide isolation for your network.

Caution

Interconnecting equipment with different reference potentials can cause unwanted currents to flow through the interconnecting cable.

These unwanted currents can cause communications errors or can damage equipment.

Be sure all equipment that you are about to connect with a communications cable either shares a common circuit reference or is isolated to prevent unwanted current flows. See the information about grounding and circuit reference points for using isolated circuits in Chapter 3.

7

Determining the Distances, Transmission Rate, and Cable for Your Network

As shown in Table 7-4, the maximum length of a network segment is determined by two factors: isolation (using an RS-485 repeater) and baud rate.

Isolation is required when you connect devices at different ground potentials. Different ground potentials can exist when grounds are physically separated by a long distance. Even over short distances, load currents of heavy machinery can cause a difference in ground potential.

Table 7-4 Maximum Length for a Network Cable

Baud Rate	Non-Isolated CPU Port ¹	CPU Port with Repeater or EM 277
9.6 kbaud to 187.5 kbaud	50 m	1,000 m
500 kbaud	Not supported	400 m
1 Mbaud to 1.5 Mbaud	Not supported	200 m
3 Mbaud to 12 Mbaud	Not supported	100 m

¹ The maximum distance allowed without using an isolator or repeater is 50 m. You measure this distance from the first node to the last node in the segment.

Using Repeaters on the Network

An RS-485 repeater provides bias and termination for the network segment. You can use a repeater for the following purposes:

- To increase the length of a network:* Adding a repeater to your network allows you to extend the network another 50 m. If you connect two repeaters with no other nodes in between (as shown in Figure 7-18), you can extend the network to the maximum cable length for the baud rate. You can use up to 9 repeaters in series on a network, but the total length of the network must not exceed 9600 m.
- To add devices to a network:* Each segment can have a maximum of 32 devices connected up to 50 m at 9600 baud. Using a repeater allows you to add another segment (32 devices) to the network.
- To electrically isolate different network segments:* Isolating the network improves the quality of the transmission by separating the network segments which might be at different ground potentials.

A repeater on your network counts as one of the nodes on a segment, even though it is not assigned a network address.

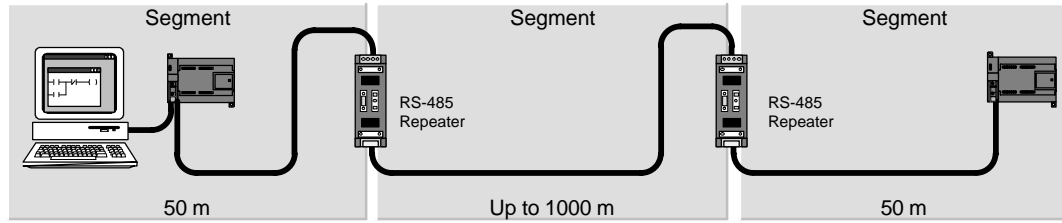

Figure 7-18 Sample Network with Repeater

Selecting the Network Cable

S7-200 networks use the RS-485 standard on twisted pair cables. Table 7-5 lists the specifications for the network cable. You can connect up to 32 devices on a network segment.

Table 7-5 General Specifications for Network Cable

Specifications	Description
Cable type	Shielded, twisted pair
Loop resistance	$\leq 115 \Omega/\text{km}$
Effective capacitance	30 pF/m
Nominal impedance	Approximately 135 Ω to 160 Ω (frequency = 3 MHz to 20 MHz)
Attenuation	0.9 dB/100 m (frequency = 200 kHz)
Cross-sectional core area	0.3 mm ² to 0.5 mm ²
Cable diameter	8 mm ± 0.5 mm

7

Connector Pin Assignments

The communications ports on the S7-200 CPU are RS-485 compatible on a nine-pin subminiature D connector in accordance with the PROFIBUS standard as defined in the European Standard EN 50170. Table 7-6 shows the connector that provides the physical connection for the communications port and describes the communications port pin assignments.

Table 7-6 Pin Assignments for the S7-200 Communications Port

Connector	Pin Number	PROFIBUS Signal	Port 0/Port 1
	1	Shield	Chassis ground
	2	24 V Return	Logic common
	3	RS-485 Signal B	RS-485 Signal B
	4	Request-to-Send	RTS (TTL)
	5	5 V Return	Logic common
	6	+5 V	+5 V, 100 Ω series resistor
	7	+24 V	+24 V
	8	RS-485 Signal A	RS-485 Signal A
	9	Not applicable	10-bit protocol select (input)
	Connector shell	Shield	Chassis ground

Biasing and Terminating the Network Cable

Siemens provides two types of network connectors that you can use to easily connect multiple devices to a network: a standard network connector (see Table 7-6 for the pin assignments), and a connector that includes a programming port, which allows you to connect a programming station or an HMI device to the network without disturbing any existing network connections. The programming port connector passes all signals (including the power pins) from the S7-200 through to the programming port, which is especially useful for connecting devices that draw power from the S7-200 (such as a TD 200).

Both connectors have two sets of terminal screws to allow you to attach the incoming and outgoing network cables. Both connectors also have switches to bias and terminate the network selectively. Figure 7-19 shows typical biasing and termination for the cable connectors.

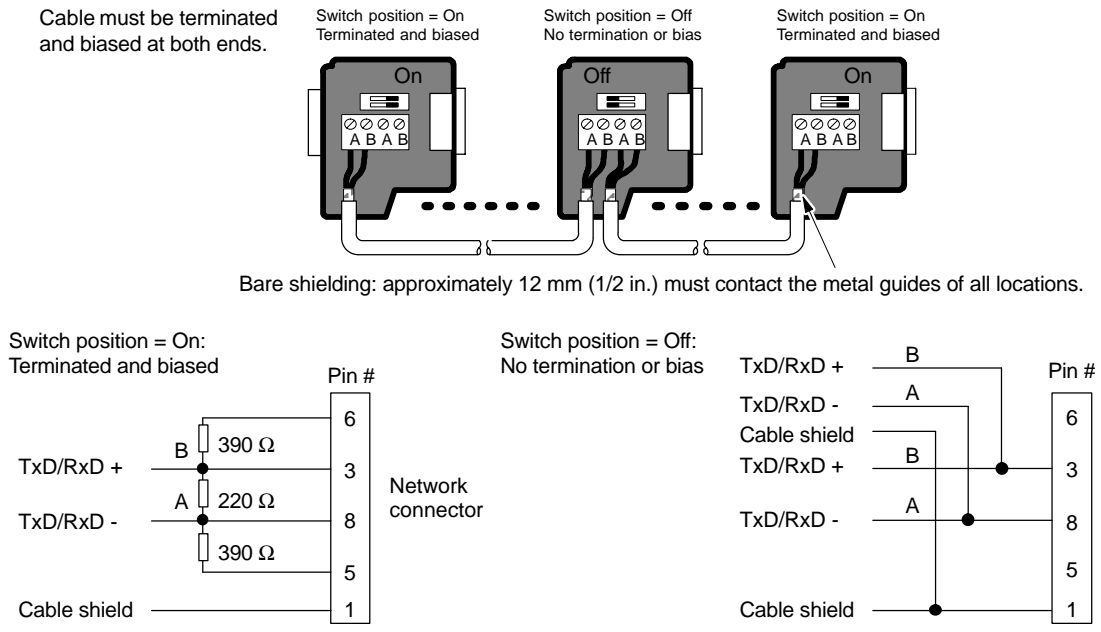

Figure 7-19 Bias and Termination of the Network Cable

Choosing the CP Card or PC/PPI Cable for Your Network

As shown in Table 7-7, STEP 7–Micro/WIN supports several CP cards that allow the programming station (your computer or SIMATIC programming device) to act as a network master.

The CP cards contain dedicated hardware to assist the programming station in managing a multi-master network and can support different protocols at several baud rates. The PC/PPI cable also allows you to enable multiple masters.

Each CP card provides a single RS-485 port for connection to the network. The CP 5511 PCMCIA card has an adapter that provides the 9-pin D port. You connect one end of the cable to the RS-485 port of the card and connect the other end to a programming port connector on your network.

If you are using a CP card with PPI communications: STEP 7–Micro/WIN does not support two different applications running on the same CP card at the same time. You must close the other application before connecting STEP 7–Micro/WIN to the network through the CP card.

Caution

Using a non-isolated RS-485-to-RS-232 converter can damage the RS-232 port of your computer.

The Siemens PC/PPI cable (order number 6ES7 901-3BF21-0XA0) provides electrical isolation between the RS-485 port on the S7-200 CPU and the RS-232 port that connects to your computer. If you do not use the Siemens PC/PPI cable, you must provide isolation for the RS-232 port of your computer.

Table 7-7 CP Cards and Protocols Supported by STEP 7–Micro/WIN

Configuration	Baud Rate	Protocol
PC/PPI cable ¹ Connected to the COM port on the programming station	9.6 kbaud or 19.2 kbaud	PPI
CP 5511 Type II, PCMCIA card (for a notebook computer)	9.6 kbaud to 12 Mbaud	PPI, MPI, and PROFIBUS
CP 5611 (version 3 or greater) PCI card	9.6 kbaud to 12 Mbaud	PPI, MPI, and PROFIBUS
MPI Either an integrated port on a SIMATIC programming device or a CP card for your computer (ISA card)	9.6 kbaud to 12 Mbaud	PPI, MPI, and PROFIBUS

¹ The PC/PPI cable provides electrical isolation between the RS-485 port (on the S7-200 CPU) and the RS-232 port that connects to your computer. Using a non-isolated RS-485-to-RS-232 converter could damage the RS-232 port of your computer.

Using HMI Devices on Your Network

The S7-200 CPU supports many types of HMI devices from Siemens and also from other manufacturers. While some of these HMI devices (such as the TD 200 or TP070) do not allow you to select the communications protocol used by the device, other devices (such as the OP7 and TP170) allow you to select the communications protocol for that device.

If your HMI device allows you to select the communications protocol, consider the following guidelines:

- For an HMI device connected to the communications port of the S7-200 CPU, with no other devices on the network, select either the PPI or the MPI protocol for the HMI device.
- For an HMI device connected to an EM 277 PROFIBUS module, select either the MPI or the PROFIBUS protocol.
 - If the network with the HMI device includes S7-300 or S7-400 PLCs, select the MPI protocol for the HMI device.
 - If the network with the HMI device is a PROFIBUS network, select the PROFIBUS protocol for the HMI device and select a profile consistent with the other masters on the PROFIBUS network.
- For an HMI device connected to the communications port of the S7-200 CPU which has been configured as a master, select the PPI protocol for the HMI device. PPI Advanced is optimal. The MPI and PROFIBUS protocols do not support the S7-200 CPU as a master.

Creating User-Defined Protocols with Freeport Mode





Freeport mode allows your program to control the communications port of the S7-200 CPU. You can use Freeport mode to implement user-defined communications protocols to communicate with many types of intelligent devices. Freeport mode supports both ASCII and binary protocols.

To enable Freeport mode, you use special memory bytes SMB30 (for Port 0) and SMB130 (for Port 1). Your program uses the following to control the operation of the communications port:

- Transmit instruction (XMT) and the transmit interrupt: The Transmit instruction allows the S7-200 to transmit up to 255 characters from the COM port. The transmit interrupt notifies your program in the S7-200 when the transmission has been completed.
- Receive character interrupt: The receive character interrupt notifies the user program that a character has been received on the COM port. Your program can then act on that character, based on the protocol being implemented.
- Receive instruction (RCV): The Receive instruction receives the entire message from the COM port and then generates an interrupt for your program when the message has been completely received. You use the SM memory of the S7-200 to configure the Receive instruction for starting and stopping the receiving of messages, based on defined conditions. The Receive instruction allows your program to start or stop a message based on specific characters or time intervals. Most protocols can be implemented with the Receive instruction.

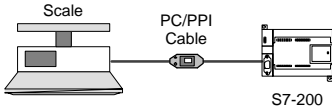
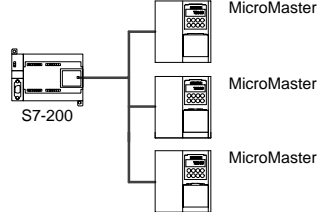
Freeport mode is active only when the S7-200 is in RUN mode. Setting the S7-200 to STOP mode halts all Freeport communications, and the communications port then reverts to the PPI protocol with the settings which were configured in the system block of the S7-200.

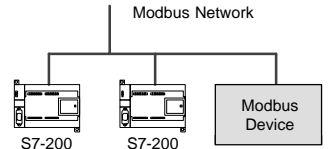
Table 7-8 Using Freeport Mode

Network Configuration		Description
Using Freeport over an RS-232 connection		<p>Example: Using an S7-200 with an electronic scale that has an RS-232 port.</p> <ul style="list-style-type: none"> ■ PC/PPI cable connects the RS-232 port on the scale to the RS-485 port on the S7-200 CPU. ■ S7-200 CPU uses Freeport to communicate with the scale. ■ Baud rate can be from 1200 baud to 115.2 kbaud. ■ User program defines the protocol.
Using USS protocol		<p>Example: Using an S7-200 with SIMODRIVE MicroMaster drives.</p> <ul style="list-style-type: none"> ■ STEP 7–Micro/WIN provides a USS library. ■ S7-200 CPU is a master, and the drives are slaves. <p> Refer to the <i>Tips and Tricks on the documentation CD for a sample USS program. See Tip 28.</i></p>
Creating a user program that emulates a slave device on another network		<p>Example: Connecting S7-200 CPUs to a Modbus network.</p> <ul style="list-style-type: none"> ■ User program in the S7-200 emulates a Modbus slave. ■ STEP 7–Micro/WIN provides a Modbus library. <p> Refer to the <i>Tips and Tricks on the documentation CD for a sample Modbus program. See Tip 41.</i></p>

Using the PC/PPI Cable and Freeport Mode with RS-232 Devices

You can use the PC/PPI cable and the Freeport communications functions to connect the S7-200 CPUs to many devices that are compatible with the RS-232 standard.

The PC/PPI cable is in Transmit mode when data is transmitted from the RS-232 port to the RS-485 port. The cable is in Receive mode when it is idle or is transmitting data from the RS-485 port to the RS-232 port. The cable changes from Receive to Transmit mode immediately when it detects characters on the RS-232 transmit line.

The PC/PPI cable supports baud rates between 1200 baud and 115.2 kbaud. Use the DIP switches on the housing of the PC/PPI cable to configure the cable for the correct baud rate. Table 7-9 shows the baud rates and switch positions.

The cable switches back to Receive mode when the RS-232 transmit line is in the idle state for a period of time defined as the turnaround time of the cable. The baud rate selection of the cable determines the turnaround time, as shown in Table 7-9.

If you are using the PC/PPI cable in a system where Freeport communications are used, the program in the S7-200 must comprehend the turnaround time for the following situations:

- The S7-200 responds to messages transmitted by the RS-232 device.

After the S7-200 receives a request message from the RS-232 device, the S7-200 must delay the transmission of a response message for a period of time greater than or equal to the turnaround time of the cable.

- The RS-232 device responds to messages transmitted from the S7-200.

After the S7-200 receives a response message from the RS-232 device, the S7-200 must delay the transmission of the next request message for a period of time greater than or equal to the turnaround time of the cable.

In both situations, the delay allows the PC/PPI cable sufficient time to switch from Transmit mode to Receive mode so that data can be transmitted from the RS-485 port to the RS-232 port.

Table 7-9 Turnaround Time and Settings

Baud Rate	Turnaround Time	Settings (1 = Up)
38400 to 115200	0.5 ms	000
19200	1.0 ms	001
9600	2.0 ms	010
4800	4.0 ms	011
2400	7.0 ms	100
1200	14.0 ms	101

Using Modems and STEP 7–Micro/WIN with Your Network

STEP 7–Micro/WIN version 3.2 uses the standard Windows Phone and Modem Options for selecting and configuring telephone modems. The Phone and Modem Options are under the Windows Control Panel. Using the Windows setup options for modems allows you to:

- Use most internal and external modems supported by Windows.
- Use the standard configurations for most modems supported by Windows.
- Use the standard Windows dialing rules for selection of locations, country and area code support, pulse or tone dialing, and calling card support.
- Use higher baud rates when communicating to the EM 241 Modem module.

Use the Windows control panel to display the Modem Properties dialog box. This dialog box allows you to configure the local modem. You select your modem from the list of modems supported by Windows. If your modem type is not listed in the Windows modem dialog box, select a type that is the closest match for your modem, or contact your modem vendor to acquire the modem configuration files for Windows.



Figure 7-20 Configuring the Local Modem

STEP 7–Micro/WIN also lets you use radio and cellular modems. These modem types do not appear in the Windows Modem Properties dialog box, but are available when configuring a connection for STEP 7–Micro/WIN.

Configuring a Modem Connection

A connection associates an identifying name with the physical properties of the connection. For a telephone modem these properties include the type of modem, 10 or 11 bit protocol selections, and timeouts. For cellular modems the connection allows setting of a PIN and other parameters. Radio modem properties include selections for baud rate, parity, flow control and other parameters.



Connection Wizard

Adding a Connection

Use the Connection wizard to add a new connection, remove, or edit a connection as shown in Figure 7-21.

1. Double-click the icon in the Communications Setup window.
2. Double-click the PC/PPI cable to open the PG/PC interface. Select the PPI cable and click the Properties button. On the Local Connection tab, check the Modem Connection box.
3. Open the Communications dialog box again, and double-click the modem Connect icon.
4. Click the Settings button to display the Modem Connections Settings dialog box.
5. Click the Add button to start the Add Modem Connection wizard.
6. Configure the connection as prompted by the wizard.

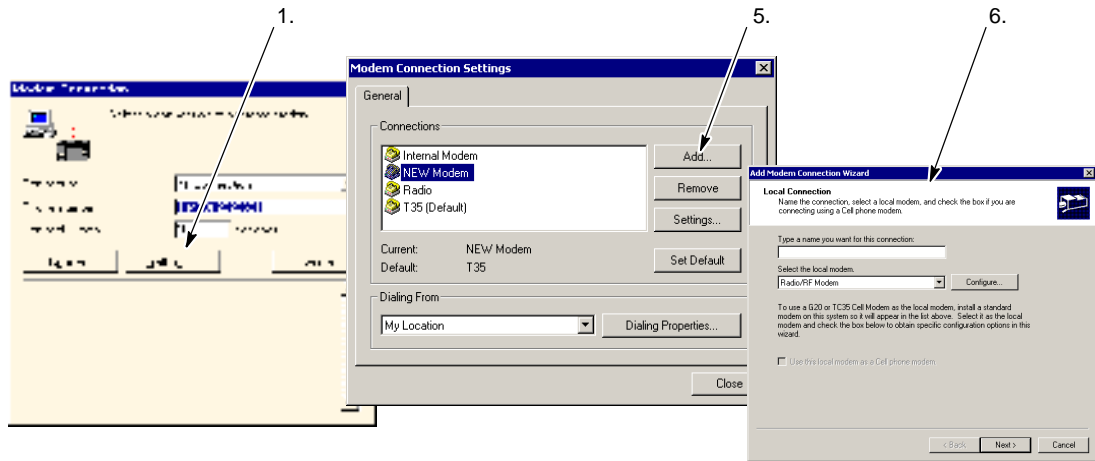

Figure 7-21 Adding a Modem Connection

Connecting to the S7-200 with a Modem

After you have added a modem connection, you can connect to an S7-200 CPU.

1. Open the Communications dialog box and double-click on the Connect icon to display the Modem Connection dialog box.
2. In the Modem Connection dialog box, click Connect to dial the modem.

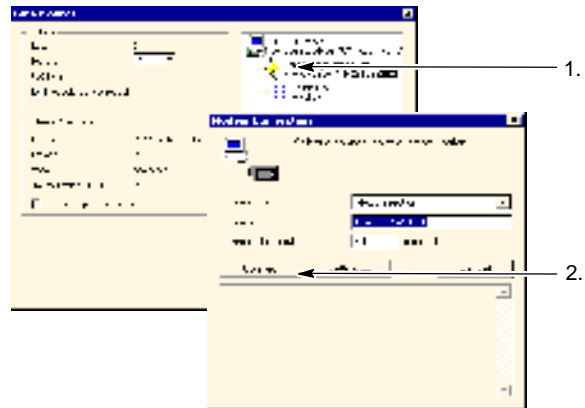

Figure 7-22 Connecting to the S7-200

Configuring a Remote Modem

The remote modem is the modem that is connected to the S7-200. If the remote modem is an EM 241 Modem module, no configuration is required. If you are connecting to a stand-alone modem or cell modem, you must configure the connection.



The Modem Expansion wizard configures the remote modem which is connected to the S7-200 CPU. Special modem configurations are required in order to properly communicate with the RS-485 half duplex port of the S7-200 CPU. Simply select the type of modem, and enter the information as prompted by the wizard. For more information, refer to the online help.

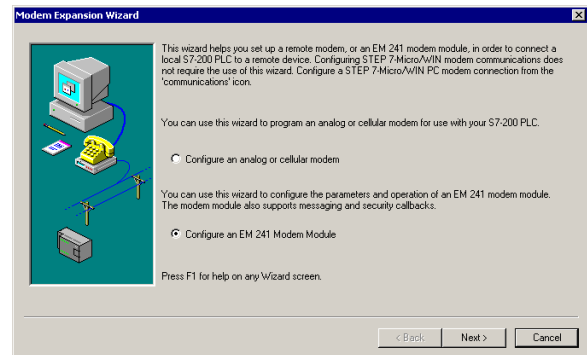

Figure 7-23 Modem Expansion Wizard

Using a Modem with the PC/PPI Cable

You can use a PC/PPI cable to connect the RS-232 communications port of a modem to an S7-200 CPU. See Figure 7-24. Switches 1, 2, and 3 on the PC/PPI cable set the baud rate. Switch 4 selects either a 10-bit or 11-bit PPI protocol. Switch 5 selects either the Data Communications Equipment (DCE) or Data Terminal Equipment (DTE) mode. Switch 6 (if present) selects the operation of the RTS signal on the RS-232 port of the PC/PPI cable.

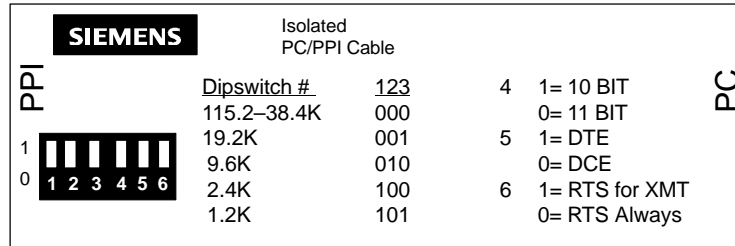

Figure 7-24 Settings for the PC/PPI Cable

Modems normally use the RS-232 control signals (such as RTS, CTS, and DTR) to allow a computer to control the modem. When you use a modem with a PC/PPI cable, you must configure the modem to operate without these signals. To determine the commands required for configuring the modem, consult the documentation for your specific modem.

Switch 4 of the PC/PPI cable selects either a 10-bit or 11-bit mode for PPI protocol. Use switch 4 only when the S7-200 is connected to STEP 7-Micro/WIN with a modem. Otherwise, set switch 4 for 11-bit mode to ensure proper operation with other devices.

Switch 5 of the PC/PPI cable allows you to set the RS-232 port of the cable to either DCE or DTE mode. If you are using the PC/PPI cable with STEP 7-Micro/WIN or if the PC/PPI cable is connected to a computer, set the PC/PPI cable to DCE mode. If you are using the PC/PPI cable with a modem (which is a DCE device), set the PC/PPI cable to DTE mode. This eliminates the need to install a null modem adapter between the PC/PPI cable and the modem. Depending on the connector on the modem, you might still need to use a 9-pin-to-25-pin adapter.

Switch 6 of the PC/PPI cable selects the operation of the RTS signal on the RS-232 connector. Selecting "RTS for XMT" causes the RTS signal to be active when the S7-200 is transmitting on the RS-485 port, and the RTS signal to be inactive when the S7-200 is receiving data. Selecting "RTS Always" causes the RTS signal to always be active on the RS-232 port of the PC/PPI cable, regardless of whether the S7-200 is transmitting or receiving. Switch 6 affects only the RTS signal when the PC/PPI cable is set for DTE mode.

Figure 7-25 shows the pin assignment for a common modem adapter.

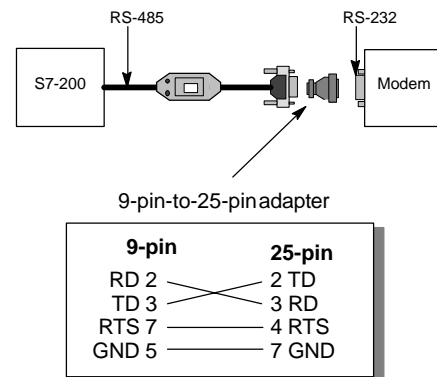

Figure 7-25 Pin Assignments for Adapters

Table 7-10 shows the pin numbers and functions for the RS-485 and RS-232 ports of the PC/PPI cable in DTE mode. Table 7-11 shows the pin numbers and functions for the RS-485 and RS-232 ports of the PC/PPI cable in DCE mode. The PC/PPI cable supplies RTS only when it is in DTE mode.

Table 7-10 Pin-outs for RS-485 and RS-232 DTE Connector

RS-485 Connector Pin-out		RS-232 DTE Connector Pin-out ¹	
Pin	Signal Description	Pin	Signal Description
1	Ground (RS-485 logic ground)	1	<i>Not used</i> : Data Carrier Detect (DCD)
2	24 V Return (RS-485 logic ground)	2	Receive Data (RD) (input to PC/PPI cable)
3	Signal B (Rx/D/TxD+)	3	Transmit Data (TD) (output from PC/PPI cable)
4	RTS (TTL level)	4	<i>Not used</i> : Data Terminal Ready (DTR)
5	Ground (RS-485 logic ground)	5	Ground (RS-232 logic ground)
6	NC (No connect)	6	<i>Not used</i> : Data Set Ready (DSR)
7	24 V Supply	7	Request To Send (RTS) (switch selectable)
8	Signal A (Rx/D/TxD-)	8	<i>Not used</i> : Clear To Send (CTS)
9	Protocol select	9	<i>Not used</i> : Ring Indicator (RI)

¹ A conversion from female to male, and a conversion from 9-pin to 25-pin, might be required for modems

Table 7-11 Pin-outs for RS-485 and RS-232 DCE Connector

RS-485 Connector Pin-out		RS-232 DCE Connector Pin-out	
Pin	Signal Description	Pin	Signal Description
1	Ground (RS-485 logic ground)	1	<i>Not used</i> : Data Carrier Detect (DCD)
2	24 V Return (RS-485 logic ground)	2	Receive Data (RD) (output from PC/PPI cable)
3	Signal B (Rx/D/TxD+)	3	Transmit Data (TD) (input to PC/PPI cable)
4	RTS (TTL level)	4	<i>Not used</i> : Data Terminal Ready (DTR)
5	Ground (RS-485 logic ground)	5	Ground (RS-232 logic ground)
6	NC (No connect)	6	<i>Not used</i> : Data Set Ready (DSR)
7	24 V Supply	7	<i>Not used</i> : Request To Send (RTS)
8	Signal A (Rx/D/TxD-)	8	<i>Not used</i> : Clear To Send (CTS)
9	Protocol select	9	<i>Not used</i> : Ring Indicator (RI)

Advanced Topics

Optimizing the Network Performance

The following factors affect network performance (with baud rate and number of masters having the greatest effect):

- Baud rate: Operating the network at the highest baud rate supported by all devices has the greatest effect on the network.
- Number of masters on the network: Minimizing the number of masters on a network also increases the performance of the network. Each master on the network increases the overhead requirements of the network; having fewer masters lessens the overhead.
- Selection of master and slave addresses: The addresses of the master devices should be set so that all of the masters are at sequential addresses with no gaps between addresses. Whenever there is an address gap between masters, the masters continually check the addresses in the gap to see if there is another master wanting to come online. This checking requires time and increases the overhead of the network. If there is no address gap between masters, no checking is done and so the overhead is minimized. You can set the slave addresses to any value without affecting network performance, as long as the slaves are not between masters. Slaves between masters increase the network overhead in the same way as having address gaps between masters.
- Gap update factor (GUF): Used only when an S7-200 CPU is operating as a PPI master, the GUF tells the S7-200 how often to check the address gap for other masters. You use STEP 7–Micro/WIN to set the GUF in the CPU configuration for a CPU port. This configures the S7-200 to check address gaps only on a periodic basis. For GUF=1, the S7-200 checks the address gap every time it holds the token; for GUF=2, the S7-200 checks the address gap once every two times it holds the token. If there are address gaps between masters, a higher GUF reduces the network overhead. If there are no address gaps between masters, the GUF has no effect on performance. Setting a large number for the GUF causes long delays in bringing masters online, because the addresses are checked less frequently. The default GUF setting is 10.
- Highest station address (HSA): Used only when an S7-200 CPU is operating as a PPI master, the HSA defines the highest address at which a master should look for another master. You use STEP 7–Micro/WIN to set the HSA in the CPU configuration for a CPU port. Setting an HSA limits the address gap which must be checked by the last master (highest address) in the network. Limiting the size of the address gap minimizes the time required to find and bring online another master. The highest station address has no effect on slave addresses: masters can still communicate with slaves which have addresses greater than the HSA. As a general rule, set the highest station address on all masters to the same value. This address should be greater than or equal to the highest master address. The default value for the HSA is 31.

Calculating the Token Rotation Time for a Network

In a token-passing network, the only station that can initiate communications is the station that holds the token. The token rotation time (the time required for the token to be circulated to each of the masters in the logical ring) measures the performance of your network.

Figure 7-26 provides a sample network as an example for calculating the token rotation time for a multiple-master network. In this example, the TD 200 (station 3) communicates with the CPU 222 (station 2), the TD 200 (station 5) communicates with the CPU 222 (station 4), and so on. The two CPU 224 modules use the Network Read and Network Write instructions to gather data from the other S7-200s: CPU 224 (station 6) sends messages to stations 2, 4, and 8, and the CPU 224 (station 8) sends messages to stations 2, 4, and 6. In this network, there are six master stations (the four TD 200 units and the two CPU 224 modules) and two slave stations (the two CPU 222 modules).



Tips and Tricks

Refer to the *Tips and Tricks* on the documentation CD for a discussion about token rotation. See *Tip 42*.

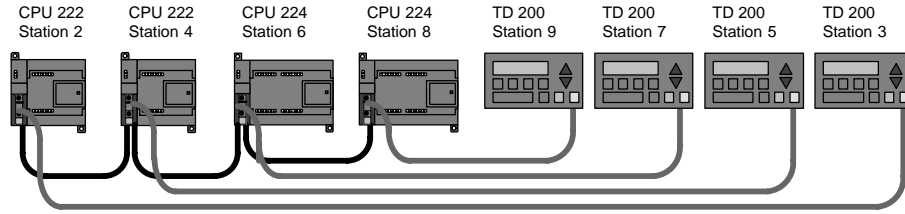

Figure 7-26 Example of a Token-Passing Network

In order for a master to send a message, it must hold the token. For example: When station 3 has the token, it initiates a request message to station 2 and then it passes the token to station 5. Station 5 then initiates a request message to station 4 and then passes the token to station 6. Station 6 then initiates a message to station 2, 4, or 8, and passes the token to station 7. This process of initiating a message and passing the token continues around the logical ring from station 3 to station 5, station 6, station 7, station 8, station 9, and finally back to station 3. The token must rotate completely around the logical ring in order for a master to be able to send a request for information. For a logical ring of six stations, sending one request message per token hold to read or write one double-word value (four bytes of data), the token rotation time is approximately 900 ms at 9600 baud. Increasing the number of bytes of data accessed per message or increasing the number of stations increases the token rotation time.

The token rotation time is determined by how long each station holds the token. You can determine the token rotation time for your multiple-master network by adding the times that each master holds the token. If the PPI master mode has been enabled (under the PPI protocol on your network), you can send messages to other S7-200s by using the Network Read and Network Write instructions with the S7-200. If you send messages using these instructions, you can use the following formula to calculate the approximate token rotation time, based on the following assumptions: each station sends one request per token hold, the request is either a read or write request for consecutive data locations, there is no conflict for use of the one communications buffer in the S7-200, and there is no S7-200 that has a scan time longer than about 10 ms.

7

Token hold time (T_{hold}) = (128 overhead + n data char) x 11 bits/char x 1/baud rate	
Token rotation time (T_{rot}) = T_{hold} of master 1 + T_{hold} of master 2 + . . . + T_{hold} of master m	
where	n is the number of data characters (bytes) m is the number of masters

The following equations calculate the rotation times (one “bit time” equals the duration of one signaling period) for the example shown in Figure 7-26:

$$\begin{aligned}
 T \text{ (token hold time)} &= (128 + 4 \text{ char}) \times 11 \text{ bits/char} \times 1/9600 \text{ bit times/s} \\
 &= 151.25 \text{ ms per master} \\
 T \text{ (token rotation time)} &= 151.25 \text{ ms per master} \leq 6 \text{ masters} \\
 &= 907.5 \text{ ms}
 \end{aligned}$$



Tip
SIMATIC NET COM PROFIBUS software provides an analyzer to determine network performance.

Comparing Token Rotation Times

Table 7-12 shows comparisons of the token rotation time versus the number of stations, amount of data, and the baud rate. The times are figured for a case where you use the Network Read and Network Write instructions with the S7-200 CPU or other master devices.

Table 7-12 Token Rotation Time (in Seconds)

Baud Rate	Bytes Transferred	Number of Masters								
		2	3	4	5	6	7	8	9	10
9.6 kbaud	1	0.30	0.44	0.59	0.74	0.89	1.03	1.18	1.33	1.48
	16	0.33	0.50	0.66	0.83	0.99	1.16	1.32	1.49	1.65
19.2 kbaud	1	0.15	0.22	0.30	0.37	0.44	0.52	0.59	0.67	0.74
	16	0.17	0.25	0.33	0.41	0.50	0.58	0.66	0.74	0.83
187.5 kbaud	1	0.009	0.013	0.017	0.022	0.026	0.030	0.035	0.039	0.043
	16	0.011	0.016	0.021	0.026	0.031	0.037	0.042	0.047	0.052

7

Understanding the Connections That Link the Network Devices

Network devices communicate through individual connections, which are private links between the master and slave devices. As shown in Figure 7-27, the communications protocols differ in how the connections are handled:

- The PPI protocol utilizes one shared connection among all of the network devices.
- The PPI Advanced, MPI, and PROFIBUS protocols utilize separate connections between any two devices communicating with each other.

When using PPI Advanced, MPI, or PROFIBUS, a second master cannot interfere with a connection that has been established between a master and a slave. S7-200 CPUs and EM 277s always reserve one connection for STEP 7–Micro/WIN and one connection for HMI devices. Other master devices cannot use these reserved connections. This ensures that you can always connect at least one programming station and at least one HMI device to the S7-200 CPU or EM 277 when the master is using a protocol that supports connections, such as PPI Advanced.

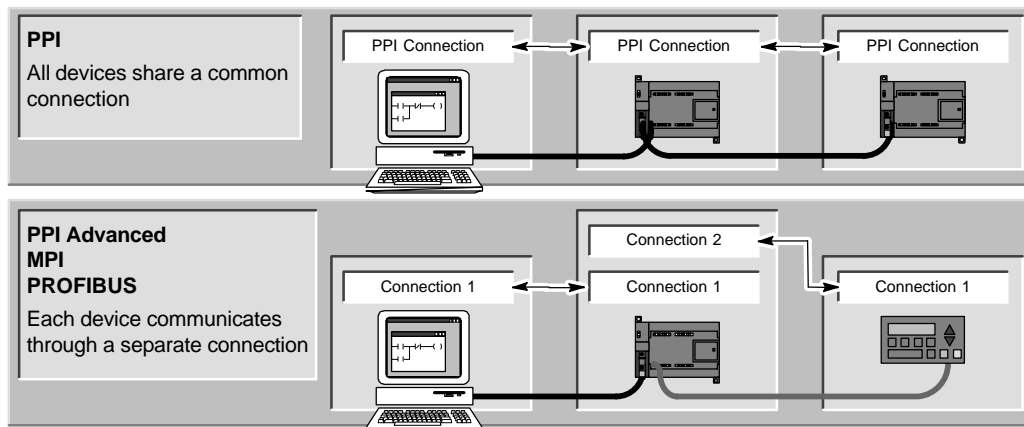

Figure 7-27 Managing the Communications Connections

As shown in Table 7-13, the S7-200 CPU or EM 277 provide a specific number of connections. Each port (Port 0 and Port 1) of an S7-200 CPU supports up to four separate connections. (This allows a maximum of eight connections for the S7-200 CPU.) This is in addition to the shared PPI connection. An EM 277 supports six connections.

Table 7-13 Capabilities of the S7-200 CPU and EM 277 Modules

Module	Baud Rate	Connections	Protocols Supported	
S7-200 CPU	Port 0	9.6 kbaud, 19.2 kbaud, or 187.5 kbaud	4	PPI, PPI Advanced, MPI, and PROFIBUS ¹
	Port 1	9.6 kbaud, 19.2 kbaud, or 187.5 kbaud	4	PPI, PPI Advanced, MPI, and PROFIBUS ¹
EM 277 Module	9.6 kbaud to 12 Mbaud	6 per module	PPI Advanced, MPI, and PROFIBUS	

¹ For Port 0 and Port 1 of the S7-200 CPU, you can use MPI and PROFIBUS only when communicating with an S7-200 device which is a slave.

Working with Complex Networks

For the S7-200, complex networks typically have multiple S7-200 masters that use the Network Read (NETR) and Network Write (NETW) instructions to communicate with other devices on a PPI network. Complex networks typically present special problems that can block a master from communicating with a slave.

If the network is running at a lower baud rate (such as 9.6 kbaud or 19.2 kbaud), then each master completes the transaction (read or write) before passing the token. At 187.5 kbaud, however, the master issues a request to a slave and then passes the token, which leaves an outstanding request at the slave.

Figure 7-28 shows a network with potential communications conflicts. In this network, Station 1, Station 2, and Station 3 are masters, using the Network Read or Network Write instructions to communicate with Station 4. The Network Read and Network Write instructions use PPI protocol so all of the S7-200s share the single PPI connection in Station 4.

In this example, Station 1 issues a request to Station 4. For baud rates above 19.2 kbaud, Station 1 then passes the token to Station 2. If Station 2 attempts to issue a request to Station 4, the request from Station 2 is rejected because the request from Station 1 is still present. All requests to Station 4 will be rejected until Station 4 completes the response to Station 1. Only after the response has been completed can another master issue a request to Station 4.

To avoid this conflict for the communications port on Station 4, consider making Station 4 the only master on the network, as shown in Figure 7-29. Station 4 then issues the read/write requests to the other S7-200s.

Not only does this configuration ensure that there is no conflict in communications, but it also reduces the overhead caused by having multiple masters and allows the network to operate more efficiently.

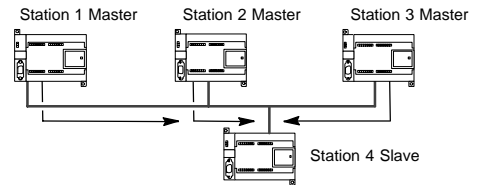

Figure 7-28 Communications Conflict

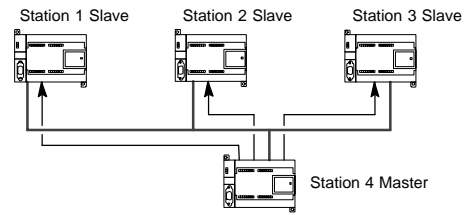

Figure 7-29 Avoiding Conflict

For some applications, however, reducing the number of masters on the network is not an option. When there are several masters, you must manage the token rotation time and ensure that the network does not exceed the target token rotation time. (The token rotation time is the amount of time that elapses from when a master passes the token until that master receives the token again.)

Table 7-14 HSA and Target Token Rotation Time

HSA	9.6 kbaud	19.2 kbaud	187.5 kbaud
HSA=15	0.613 s	0.307 s	31 ms
HSA=31	1.040 s	0.520 s	53 ms
HSA=63	1.890 s	0.950 s	97 ms
HSA=126	3.570 s	1.790 s	183 ms

If the time required for the token to return to the master is greater than a target token rotation time, then the master is not allowed to issue a request. The master can issue a request only when the actual token rotation time is less than the target token rotation time.

The highest station address (HSA) and the baud rate settings for the S7-200 determine the target token rotation time. Table 7-14 lists target rotation times.

For the slower baud rates, such as 9.6 kbaud and 19.2 kbaud, the master waits for the response to its request before passing the token. Because processing the request/response cycle can take a relatively long time in terms of the scan time, there is a high probability that every master on the network can have a request ready to transmit every time it holds the token. The actual token rotation time would then increase, and some masters might not be able to process any requests. In some situations, a master might only rarely be allowed to process requests.

For example: Consider a network of 10 masters that transmit 1 byte at 9.6 kbaud that is configured with an HSA of 15. For this example, each of the masters always has a message ready to send. As shown in Table 7-14, the target rotation time for this network is 0.613 s. However, based on the performance data listed in Table 7-12, the actual token rotation time required for this network is 1.48 s. Because the actual token rotation time is greater than the target token rotation time, some of the masters will not be allowed to transmit a message until some later rotation of the token.

You have two basic options for improving a situation where the actual token rotation time is greater than the target token rotation time:

- You can reduce actual token rotation time by reducing the number of masters on your network. Depending on your application, this might not be a feasible solution.
- You can increase the target token rotation time by increasing the HSA for all of the master devices on the network.

Increasing the HSA can cause a different problem for your network by affecting the amount of time that it takes for a S7-200 to switch to master mode and enter the network. If you use a timer to ensure that the Network Read or Network Write instruction completes its execution within a specified time, the delay in initializing master mode and adding the S7-200 as a master on the network can cause the instruction to time out. You can minimize the delay in adding masters by reducing the Gap Update Factor (GUF) for all masters on the network.

Because of the manner in which requests are posted to and left at the slave for 187.5 kbaud, you should allow extra time when selecting the target token rotation time. For 187.5 kbaud, the actual token rotation time should be approximately half of the target token rotation time.

To determine the token rotation time, use the performance data in Table 7-12 to determine the time required for completing the Network Read and Network Write operations. To calculate the time required for HMI devices (such as the TD 200), use the performance data for transferring 16 bytes. Calculate the token rotation time by adding the time for each device on the network. Adding all of the times together describes a worst-case scenario where all devices want to process a request during the same token rotation. This defines the maximum token rotation time required for the network.

For example: Consider a network running at 9.6 kbaud with four TD 200s and four S7-200s, with each S7-200 writing 10 bytes of data to another S7-200 every second. Use Table 7-12 to calculate the specific transfer times for the network:

4 TD 200 devices transferring 16 bytes of data =	0.66 s
4 S7-200s transferring 10 bytes of data =	<u>0.63 s</u>
Total token rotation time =	1.29 s

To allow enough time for this network to process all requests during one token rotation, set the HSA to 63. (See Table 7-14.) Selecting a target token rotation (1.89 s) that is greater than the maximum token rotation time (1.29 s) ensures that every device can transfer data on every rotation of the token.

To help improve the reliability of a multi-master network, you should also consider the following actions:

- Change the update rate for the HMI devices to allow more time between updates. For example, change the update rate for a TD 200 from “As fast as possible” to “Once per second.”
- Reduce the number of requests (and the network overhead for processing the requests) by combining the operations of Network Read or Network Write operations. For example, instead of using two Network Read operations that read 4 bytes each, use one Network Read operation that reads 8 bytes. The time to process the two requests of 4 bytes is much greater than the time to process one request for 8 bytes.
- Change the update rate of the S7-200 masters so that they do not attempt to update faster than the token rotation time.

Hardware Troubleshooting Guide and Software Debugging Tools



STEP 7–Micro/WIN provides software tools to help you debug and test your program. These features include viewing the status of the program as it is executed by the S7-200, selecting to run the S7-200 for a specified number of scans, and forcing values.

Use Table 8-1 as a guide for determining the cause and possible solution when troubleshooting problems with the S7-200 hardware.

In This Chapter

Features for Debugging Your Program	236
Displaying the Program Status	238
Using a Status Chart to Monitor and Modify the Data in the S7-200	239
Forcing Specific Values	240
Running Your Program for a Specified Number of Scans	240
Hardware Troubleshooting Guide	241

Features for Debugging Your Program

STEP 7–Micro/WIN provides several features to help you debug your program: bookmarks, cross reference tables, and run-time edits.

Using Bookmarks for Easy Program Access

You can set bookmarks in your program to make it easy to move back and forth between designated (bookmarked) lines of a long program. You can move to the next or the previous bookmarked line of your program.

Using the Cross Reference Table to Check Your Program References



Cross Reference

The cross reference table allows you to display the cross references and element usage information for your program.

The cross reference table identifies all operands used in the program, and identifies the program block, network or line location, and instruction context of the operand each time it is used.

You can toggle between symbolic and absolute view to change the representation of all operands.

Line	Operand	Block	Location	Content
1	I0.0	MAIN (OB1)	Network 1	— —
2	SMV02	MAIN (OB1)	Network 1	MOV_W
3	BLB01	MAIN (OB1)	Network 1	MOV_B
4	SM01.7	MAIN (OB1)	Network 1	— —
5	BLB1.7	MAIN (OB1)	Network 1	—(B)

Figure 8-1 Cross Reference Table

8



Tip

Double-clicking on an element in the cross reference table takes you to that part of your program or block.

Editing Your Program in RUN Mode

CPU 224 Rel. 1.10 (and higher) and CPU 226 Rel. 1.00 (and higher) models support RUN mode edits. The RUN mode edit capability is intended to allow you to make small changes to a user program with minimal disturbance to the process being controlled by the program. However, implementing this capability also allows massive program changes that could be disruptive or even dangerous.



Warning

When you download changes to an S7-200 in RUN mode, the changes immediately affect process operation. Changing the program in RUN mode can result in unexpected system operation, which could cause death or serious injury to personnel, and/or damage to equipment.

Only authorized personnel who understand the effects of RUN mode edits on system operation should perform a RUN mode edit.

To perform a program edit in RUN mode, the online S7-200 CPU must support RUN mode edits and must be in RUN mode.

1. Select the **Debug > Program Edit in RUN** menu command.
2. If the project is different than the program in the S7-200, you are prompted to save it. The RUN mode edit can be performed only on the program in the S7-200.
3. STEP 7–Micro/WIN alerts you about editing your program in RUN mode and prompts you to either continue or to cancel the operation. If you click Continue, STEP 7–Micro/WIN uploads the program from the S7-200. You can now edit your program in RUN mode. No restrictions on edits are enforced.



Tip

Positive (EU) and Negative (ED) transition instructions are shown with an operand. To view information about edge instructions, select the Cross Reference icon in the View. The Edge Usage tab lists numbers for the edge instructions in your program. Be careful not to assign duplicate edge numbers as you edit your program.

Downloading the Program in RUN Mode

RUN-mode editing allows you to download only your program block while the S7-200 is in RUN mode. Before downloading the program block in RUN mode, consider the effect of a RUN-mode modification on the operation of the S7-200 for the following situations:

- If you deleted the control logic for an output, the S7-200 maintains the last state of the output until the next power cycle or transition to STOP mode.
- If you deleted a high-speed counter or pulse output functions which were running, the high-speed counter or pulse output continues to run until the next power cycle or transition to STOP mode.
- If you deleted an Attach Interrupt instruction but did not delete the interrupt routine, the S7-200 continues to execute the interrupt routine until a power cycle or a transition to STOP mode. Likewise, if you deleted a Detach Interrupt instruction, the interrupts are not shut down until the next power cycle or transition to STOP mode.
- If you added an Attach Interrupt instruction that is conditional on the first scan bit, the event is not activated until the next power cycle or STOP-to-RUN mode transition.
- If you deleted an Enable Interrupt instruction, the interrupts continue to operate until the next power cycle or transition from RUN to STOP mode.
- If you modified the table address of a receive box and the receive box is active at the time that the S7-200 switches from the old program to the modified program, the S7-200 continues to write the data received to the old table address. Network Read and Network Write instructions function in the same manner.
- Any logic that is conditional on the state of the first scan bit will not be executed until the next power cycle or transition from STOP to RUN mode. The first scan bit is set only by the transition to RUN mode and is not affected by a RUN-mode edit.



Tip

Before you can download your program in RUN mode, the S7-200 must support RUN mode edits, the program must compile with no errors, and the communications between STEP 7–Micro/WIN and the S7-200 must be error-free.

You can download only the program block.

To download your program in RUN mode, click on the Download button or select the **File > Download** menu command. If the program compiles successfully, STEP 7–Micro/WIN downloads the program block to the S7-200.

Exiting RUN-Mode Edit

To exit RUN-mode editing, select the **Debug > Program Edit in RUN** menu command and deselect the checkmark. If you have changes that have not been saved, STEP 7–Micro/WIN prompts you either to continue editing, to download changes and exit RUN-mode editing, or to exit without downloading.

Displaying the Program Status

STEP 7–Micro/WIN allows you to monitor the status of the user program as it is being executed. When you monitor the program status, the program editor displays the status of instruction operand values.

To display the status, click the Program Status button or select the **Debug > Program Status** menu command.

Displaying the Status of the Program in LAD and FBD

STEP 7–Micro/WIN provides two options for displaying the status of LAD and FBD programs:

- End of scan status: STEP 7–Micro/WIN acquires the values for the status display across multiple scan cycles and then updates the status screen display. The status display does not reflect the actual status of each element at the time of execution. The end-of-scan status does not show status for L memory or for the accumulators.

For end of scan status, the status values are updated in all of the CPU operating modes.

- Execution status: STEP 7–Micro/WIN displays the values of the networks as the elements are executed in the S7-200. For displaying the execution status, select the **Debug > Use Execution Status** menu command.

For execution status, the status values are updated only when the CPU is in RUN mode.



Tip

STEP 7–Micro/WIN provides a simple method for changing the state of a variable. Simply select the variable and right-click to display a menu of options.

8

Configuring How the Status is Displayed in the LAD and FBD Program

STEP 7–Micro/WIN provides a variety of options for displaying the status in the program.

To configure the display option for the status screen, select the **Tools > Options** menu command and then select the Program Editor tab, as shown in Figure 8-2.

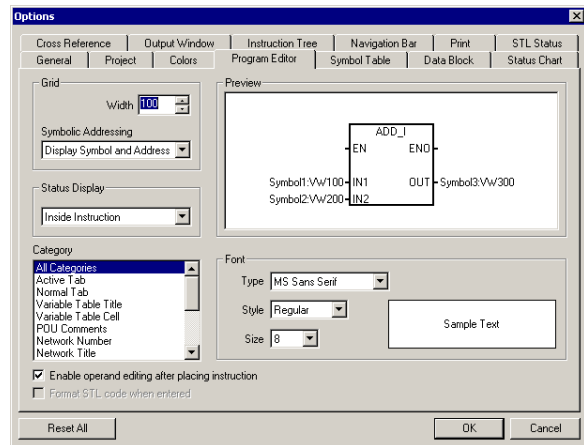

Figure 8-2 Options for the Status Display

Displaying the Status of the Program in STL

You can monitor the execution status of your STL program on an instruction-by-instruction basis. For an STL program, STEP 7–Micro/WIN displays the status of the instructions that are displayed on the screen.

STEP 7–Micro/WIN gathers status information from the S7-200, beginning from the first STL statement at the top of the editor window. As you scroll down the editor window, new information is gathered from the S7-200.

STEP 7–Micro/WIN continuously updates values on the screen. To halt the screen updates, select the Triggered Pause button. The current data remains on the screen until you deselect the Triggered Pause button.

Configuring Which Parameters Are Displayed in the STL Program

STEP 7–Micro/WIN allows you to display the status of a variety of parameters for the STL instructions. Select the **Tools > Options** menu command and then select the STL Status tab. See Figure 8-3.

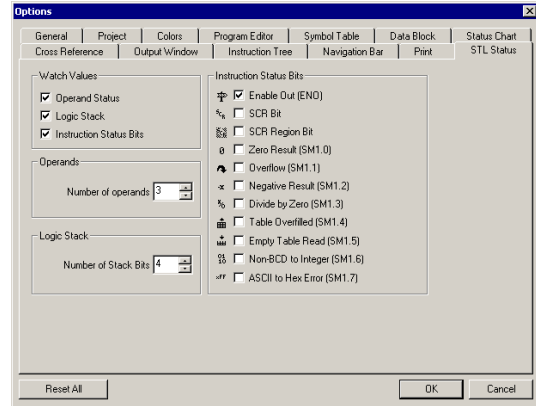

Figure 8-3 Options for Displaying STL Status

Using a Status Chart to Monitor and Modify the Data in the S7-200

The Status Chart allows you to read, write, force, and monitor variables while the S7-200 is executing your program. Select the **View > Component > Status Chart** menu command to create a status chart. Figure 8-4 shows a sample status chart.

You can create multiple status charts.

STEP 7–Micro/WIN provides toolbar icons for manipulating the status chart: Sort Ascending, Sort Descending, Single Read, Write All, Force, Unforce, Unforce All, and Read All Forced.

To select a format for a cell, select the cell and click the right mouse button to display the context menu.

	Address	Format	Current Value	New Value
1	Start_1	Bit	2#1	
2	Start_2	Bit	2#0	
3	Stop_1	Bit	2#1	
4	Stop_2	Bit	2#0	
5	High_Level	Bit	2#0	
6	Low_Level	Bit	2#0	
7	Reset	Bit	2#0	
8		Signed		
9	Pump_1	Bit	2#1	
10	Pump_2	Bit	2#0	
11	Mixer_Motor	Bit	2#0	
12	Steam_Valve	Bit	2#0	
13	Drain_Valve	Bit	2#1	
14	Drain_Pump	Bit	2#1	
15		Signed		
16	High_Lev_Reached	Bit	2#1	
17	Mix_Timer	Signed	+32767	
18	Cycle_Counter	Signed	+0	

Figure 8-4 Status Chart

Forcing Specific Values

The S7-200 allows you to force any or all of the I/O points (I and Q bits). In addition, you can also force up to 16 memory values (V or M) or analog I/O values (AI or AQ). V memory or M memory values can be forced in bytes, words, or double words. Analog values are forced as words only, on even-numbered byte boundaries, such as AIW6 or AQW14. All forced values are stored in the permanent EEPROM memory of the S7-200.

Because the forced data might be changed during the scan cycle (either by the program, by the I/O update cycle, or by the communications- processing cycle), the S7-200 reapplies the forced values at various times in the scan cycle.

- Reading the inputs:* The S7-200 applies the forced values to the inputs as they are read.
- Executing the control logic in the program:* The S7-200 applies the forced values to all immediate I/O accesses. Forced values are applied for up to 16 memory values after the program has been executed.
- Processing any communications requests:* The S7-200 applies the forced values to all read/write communications accesses.
- Writing to the outputs:* The S7-200 applies the forced values to the outputs as they are written.

You can use the Status Chart to force values. To force a new value, enter the value in the New Value column of the Status Chart, then press the Force button on the toolbar. To force an existing value, highlight the value in the Current Value column, then press the Force button.

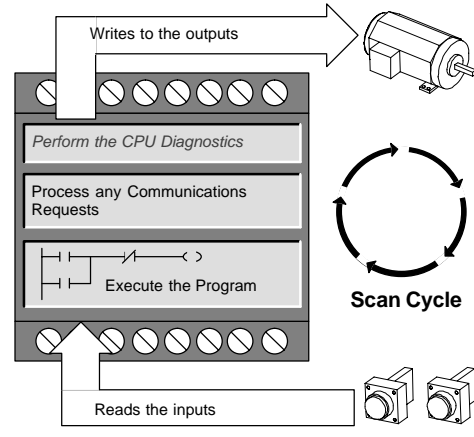

Figure 8-5 S7-200 Scan Cycle

8



Tip

The Force function overrides a Read Immediate or Write Immediate instruction. The Force function also overrides the output table that was configured for transition to STOP mode. If the S7-200 goes to STOP mode, the output reflects the forced value and not the value that was configured in the output table.

Running Your Program for a Specified Number of Scans

To help you debug your program, STEP 7–Micro/WIN allows you to run the program for a specific number of scans.

You can have the S7-200 execute only the first scan. This allows you to monitor the data in the S7-200 after the first scan. Select the **Debug > First Scan** menu command to run the first scan.

You can have the S7-200 execute your program for a limited number of scans (from 1 scan to 65,535 scans). This allows you to monitor the program as it changes variables. Select the **Debug > Multiple Scans** menu command to specify the number of scans to be executed.

Hardware Troubleshooting Guide

Table 8-1 Troubleshooting Guide for the S7-200 Hardware

Symptom	Possible Causes	Possible Solution
Outputs stop working	<ul style="list-style-type: none"> ■ The device being controlled has caused an electrical surge that damaged the output ■ User program error ■ Wiring loose or incorrect ■ Excessive load ■ Output point is forced 	<ul style="list-style-type: none"> ■ When connecting to an inductive load (such as a motor or relay), a proper suppression circuit should be used. Refer to Chapter 3. ■ Correct user program ■ Check wiring and correct ■ Check load against point ratings ■ Check the S7-200 for forced I/O
SF (System Fault) light on the S7-200 turns on	<p>The following list describes the most common error codes and causes:</p> <ul style="list-style-type: none"> ■ User programming error <ul style="list-style-type: none"> – 0003 Watchdog error – 0011 Indirect addressing – 0012 Illegal floating-point value – 0014 Range error ■ Electrical noise (0001 through 0009) ■ Component damage (0001 through 0010) 	<p>Read the fatal error code number and refer to Appendix C for information about the type of error:</p> <ul style="list-style-type: none"> ■ For a programming error, check the usage of the FOR, NEXT, JMP, LBL, and Compare instructions. ■ For electrical noise: <ul style="list-style-type: none"> – Refer to the wiring guidelines in Chapter 3. It is very important that the control panel is connected to a good ground and that high voltage wiring is not run in parallel with low voltage wiring. – Connect the M terminal on the 24 VDC Sensor Power Supply to ground.
None of the LEDs turn on	<ul style="list-style-type: none"> ■ Blown fuse ■ Reversed 24 V power wires ■ Incorrect voltage 	<p>Connect a line analyzer to the system to check the magnitude and duration of the over-voltage spikes. Based on this information, add the proper type arrestor device to your system.</p> <p>Refer to the wiring guidelines in Chapter 3 for information about installing the field wiring.</p>
Intermittent operation associated with high energy devices	<ul style="list-style-type: none"> ■ Improper grounding ■ Routing of wiring within the control cabinet ■ Too short of a delay time for the input filters 	<p>Refer to the wiring guidelines in Chapter 3.</p> <p>It is very important that the control panel is connected to a good ground and that high voltage wiring is not run in parallel with low voltage wiring.</p> <p>Connect the M terminal on the 24 VDC Sensor Power Supply to ground.</p> <p>Increase the input filter delay in the system data block.</p>
Communications network is damaged when connecting to an external device Either the port on the computer, the port on the S7-200, or the PC/PPI cable is damaged	<p>The communications cable can provide a path for unwanted currents if all non-isolated devices, such as PLCs, computers, or other devices that are connected to the network do not share the same circuit common reference.</p> <p>The unwanted currents can cause communications errors or damage to the circuits.</p>	<ul style="list-style-type: none"> ■ Refer to the wiring guidelines in Chapter 3 and to the network guidelines in Chapter 7. ■ Purchase the isolated PC/PPI cable. ■ Purchase the isolated RS-485-to-RS-485 repeater when you connect machines that do not have a common electrical reference. <p>Refer to Appendix E for information about order numbers for S7-200 equipment.</p>
Other communications problems (STEP 7–Micro/WIN)	Refer to Chapter 7 for information about network communications.	
Error handling	Refer to Appendix C for information about error codes.	

Creating a Program for the Position Module



The EM 253 Position module is an S7-200 special function module that generates the pulse trains used for open-loop control of the speed and position for either stepper motors or servo motors. It communicates with the S7-200 over the expansion I/O bus and appears in the I/O configuration as an intelligent module with eight digital outputs.

Based upon configuration information that is stored in the V memory of the S7-200, the Position module generates the pulse trains required to control motion.

To simplify the use of position control in your application, STEP 7–Micro/WIN provides a Position Control wizard that allows you to completely configure the Position module in minutes. STEP 7–Micro/WIN also provides a control panel that allows you to control, monitor and test your motion operations.

In This Chapter

Features of the Position Module	244
Configuring the Position Module	246
Position Instructions Created by the Position Control Wizard	257
Sample Programs for the Position Module	269
Monitoring the Position Module with the EM 253 Control Panel	274
Error Codes for the Position Module and the Position Instructions	276
Advanced Topics	278

Features of the Position Module

The Position module provides the functionality and performance that you need for single-axis, open-loop position control:

- Provides high-speed control, with a range from 12 pulses per second up to 200,000 pulses per second
- Supports both jerk (S curve) or linear acceleration and deceleration
- Provides a configurable measuring system that allows you to enter data either as engineering units (such as inches or centimeters) or as a number of pulses
- Provides configurable backlash compensation
- Supports absolute, relative, and manual methods of position control
- Provides continuous operation
- Provides up to 25 motion profiles, with up to 4 speed changes per profile
- Provides four different reference-point seek modes, with a choice of the starting seek direction and the final approach direction for each sequence
- Provides removable field wiring connectors for easy installation and removal

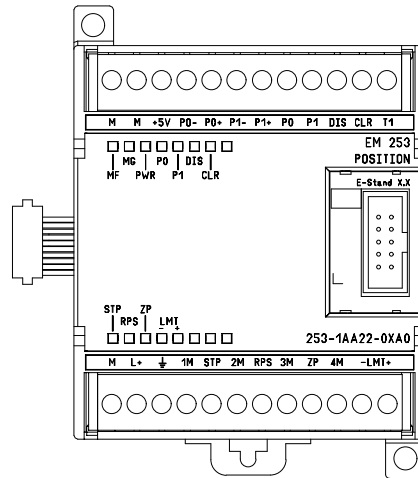

Figure 9-1 EM 253 Position Module

9

You use STEP 7–Micro/WIN to create all of the configuration and profile information used by the Position module. This information is downloaded to the S7-200 with your program blocks. Because all the information required for position control is stored in the S7-200, you can replace a Position module without having to reprogram or reconfigure the module.

The S7-200 reserves 8 bits of the process image output register (Q memory) for the interface to the Position module. Your application program in the S7-200 uses these bits to control the operation of the Position module. These 8 output bits are not connected to any of the physical field outputs of the Position module.

The Position module provides five digital inputs and four digital outputs that provide the interface to your motion application. See Table 9-1. These inputs and outputs are local to the Position module. Appendix A provides the detailed specifications for the Position module and also includes wiring diagrams for connecting the Position module to some of the more common motor driver/amplifier units.

Table 9-1 Inputs and Outputs of the Position Module

Signal	Description
STP	The STP input causes the module to stop the motion in progress. You can select the desired operation of STP within the Position Control wizard.
RPS	The RPS (Reference Point Switch) input establishes the reference point or home position for absolute move operations.
ZP	The ZP (Zero Pulse) input helps establish the reference point or home position. Typically, the motor driver/amplifier pulses ZP once per motor revolution.
LMT+ LMT–	LMT+ and LMT– inputs establish the maximum limits for motion travel. The Position Control wizard allows you to configure the operation of LMT+ and LMT– inputs.
P0 P1 P0+, P0– P1+, P1–	P0 and P1 are open drain transistor pulse outputs that control the movement and direction of movement of the motor. P0+, P0– and P1+, P1– are differential pulse outputs that provide the identical functions of P0 and P1, respectively, while providing superior signal quality. The open drain outputs and the differential outputs are all active simultaneously. Based upon the interface requirements of motor driver/amplifier, you choose which set of pulse outputs to use.
DIS	DIS is an open drain transistor output used to disable or enable the motor driver/amplifier.
CLR	CLR is an open drain transistor output used to clear the servo pulse count register.

Programming the Position Module

STEP 7–Micro/WIN provides easy-to-use tools for configuring and programming the Position module. Simply follow these steps:

1. Configure the Position module. STEP 7–Micro/WIN provides a Position Control wizard for creating the configuration/profile table and the position instructions. See page 246 for information about configuring the Position module.
2. Test the operation of the Position Module. STEP 7–Micro/WIN provides an EM 253 control panel for testing the wiring of the inputs and outputs, the configuration of the Position module, and the operation of the motion profiles. See page 274 for information about the EM 253 control panel.
3. Create the program to be executed by the S7-200. The Position Control wizard automatically creates the position instructions that you insert into your program. See page 257 for information about the position instructions. Insert the following instructions into your program:
 - To enable the Position module, insert a POSx_CTRL instruction. Use SM0.0 (Always On) to ensure that this instruction is executed every scan.
 - To move the motor to a specific location, use a POSx_GOTO or a POSx_RUN instruction. The POSx_GOTO instruction move to a location specified by the inputs from your program. The POSx_RUN instruction executes the motion profiles you configured with the Position Control wizard.
 - To use absolute coordinates for your motion, you must establish the zero position for your application. Use the a POSx_RSEEK or a POSx_LDPOS instruction to establish the zero position.
 - The other instructions that are created by the Position Control wizard provide functionality for typical applications and are optional for your specific application.
4. Compile your program and download the system block, data block, and program block to the S7-200.

**Tip**

Refer to Appendix A for information about connecting the Position module to several common stepper motor controllers.

**Tip**

To match the default settings in the Position Control wizard, set the DIP switches on the stepper motor controller to 10,000 pulses per revolution.

Configuring the Position Module



Position Control

You must create a configuration/profile table for the Position module in order for the module to control your motion application. The Position Control wizard makes the configuration process quick and easy by leading you step-by-step through the configuration process. Refer to the Advanced Topics on page 278 for detailed information about the configuration/profile table.

The Position Control wizard also allows you to create the configuration/profile table offline. You can create the configuration without being connected to an S7-200 CPU with a Position module installed.

To run the Position Control wizard, your project must have been compiled and set to symbolic addressing mode.

To start the Position Control wizard, either click the Tools icon in the navigation bar and then double-click the Position Control Wizard icon, or select the **Tools> Position Control Wizard** menu command.

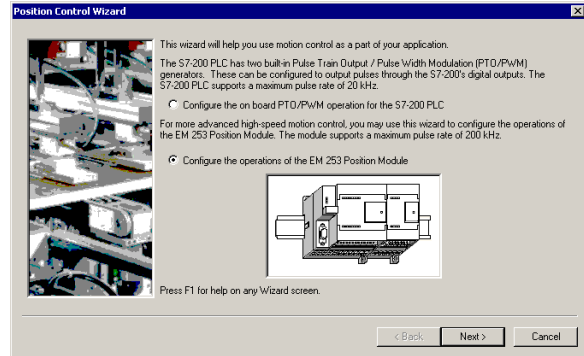

Figure 9-2 Position Control Wizard

The Position Control wizard allows you to configure either the operation of the Position module or the PTO/PWM operation of the Pulse Output instruction. After you select the option for the Position module and click Next, the wizard guides you through the steps required for configuring the Position module.

Entering the Location of the Position Module

You must define the parameters for your module and the set of motion profiles for your application by entering the module type and location. The Position Control wizard simplifies this task by automatically reading the position of the intelligent module. You only have to click the Read Modules button.

For an S7-200 CPU with firmware prior to version 1.2, you must install the intelligent module next to the CPU in order for the Position Control wizard to configure the module.

Selecting the Type of Measurement

You must select the measurement system to be used throughout the configuration. You can select to use either engineering units or pulses. If you select pulses, you do not have to specify any other information. If you select engineering units, you must enter the following data: the number of pulses required to produce one revolution of the motor (refer to the data sheet for your motor or drive), the base unit of measurement (such as inch, foot, millimeter, or centimeter), and the amount of motion (or "units") provided by one revolution of the motor.

STEP 7-Micro/WIN provides an EM253 Control Panel that allows you to modify the number of units per revolution after the Position module has been configured.

If you change the measurement system later, you must delete the entire configuration including any instructions generated by the Position Control wizard. You must then enter your selections consistent with the new measurement system.

Editing the Default Input and Output Configurations

The Position Control wizard provides an Advanced Options selection that allows you to view and edit the default input and output configurations for the Position module:

- The Input Active Levels tab changes the activation level settings. When the level is set to High, a logic 1 is read when current is flowing in the input. When the level is set to Low, a logic 1 is read when there is no current flow in the input. A logic 1 level is always interpreted as meaning the condition is active. The LEDs are illuminated when current flows in the input, regardless of activation level. (Default = active high)
- The Input Filter Times tab allows you to specify a delay time (range of 0.20 ms to 12.80 ms) for filtering the STP, RPS, LMT+, and LMT- inputs. This delay helps to filter noise on the input wiring that could cause inadvertent changes to the state of the inputs. (Default = 6.4 ms)
- The Pulse and Directional Outputs tab allows you to specify the method of controlling direction. First you must specify the polarity of the outputs.

Selecting Positive Polarity

For an application that uses positive polarity, select one of the following methods (shown in Figure 9-3) to accommodate your drive and the orientation of your application:

- The Position module emits pulses from the P0 output for positive rotation and pulses from the P1 output for negative rotation.
- The Position module emits pulses from the P0 output. The module turns on the P1 output for positive rotation and turn off the P1 output for negative rotation. (This is the default setting.)

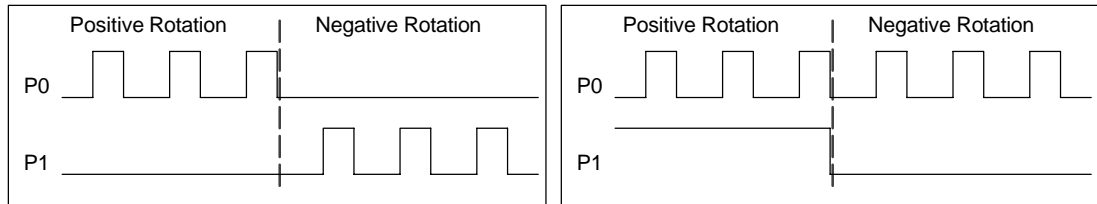

Figure 9-3 Rotation Options for Positive Polarity

Selecting Negative Polarity

For an application that uses negative polarity, select one of the following methods (shown in Figure 9-4) to accommodate your drive and the orientation of your application:

- The Position module emits pulses from the P0 output for negative rotation and pulses from the P1 output for positive rotation.
- The Position module emits pulses from the P0 output. The module turns off the P1 output for positive rotation and turn on the P1 output for negative rotation.

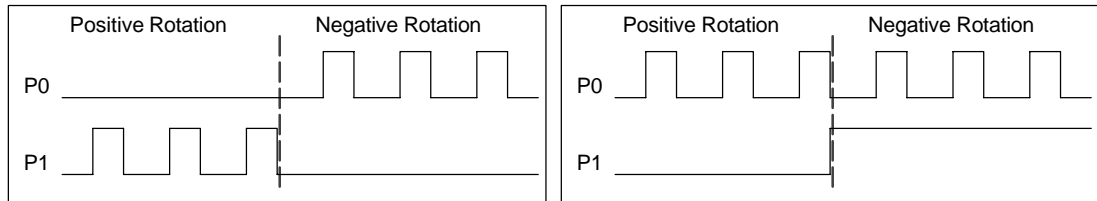

Figure 9-4 Rotation Options for Negative Polarity

Configuring the Response of the Module to the Physical Inputs

You must specify how the Position module responds to each of the LMT+ switch, the LMT– switch, and the STP input: no action (ignore the input condition), decelerate to a stop (default), or immediate stop.



Warning

Control devices can fail in unsafe conditions, and can result in unpredictable operation of controlled equipment. Such unpredictable operations could result in death or serious personal injury, and/or equipment failure.

The limit and stop functions in the Position Module are electronic logic implementations that do not provide the level of protection provided by electromechanical controls. Consider using an emergency stop function, electromechanical overrides, or redundant safeguards that are independent of the Position module and the S7-200 CPU.

Entering the Maximum and Start/Stop Speeds

You must specify the maximum speed (MAX_SPEED) and Start/Stop Speed (SS_SPEED) for your application:

- MAX_SPEED:** Enter the value for the optimum operating speed of your application within the torque capability of your motor. The torque required to drive the load is determined by friction, inertia, and the acceleration/deceleration times. The Position Control wizard calculates and displays the minimum speed that can be controlled by the Position module for a specified MAX_SPEED.
- SS_SPEED:** Enter a value within the capability of your motor to drive your load at low speeds. If the SS_SPEED value is too low, the motor and load could vibrate or move in short jumps at the beginning and end of travel. If the SS_SPEED value is too high, the motor could lose pulses on start up, and the load could overdrive the motor when attempting to stop.

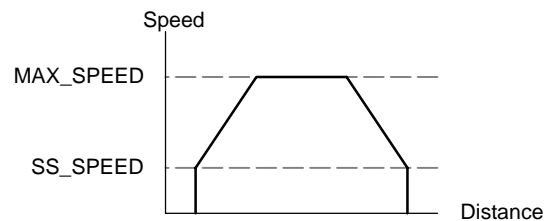

Figure 9-5 Maximum Speed and Start/Stop Speed

Motor data sheets have different ways of specifying the start/stop (or pull-in/pull-out) speed for a motor and given load. Typically, a useful SS_SPEED value is 5% to 15% of the MAX_SPEED value. The SS_SPEED value must be greater than the minimum speed displayed from your specification of MAX_SPEED.

To help you select the correct speeds for your application, refer to the data sheet for your motor. Figure 9-6 shows a typical motor torque/speed curve.

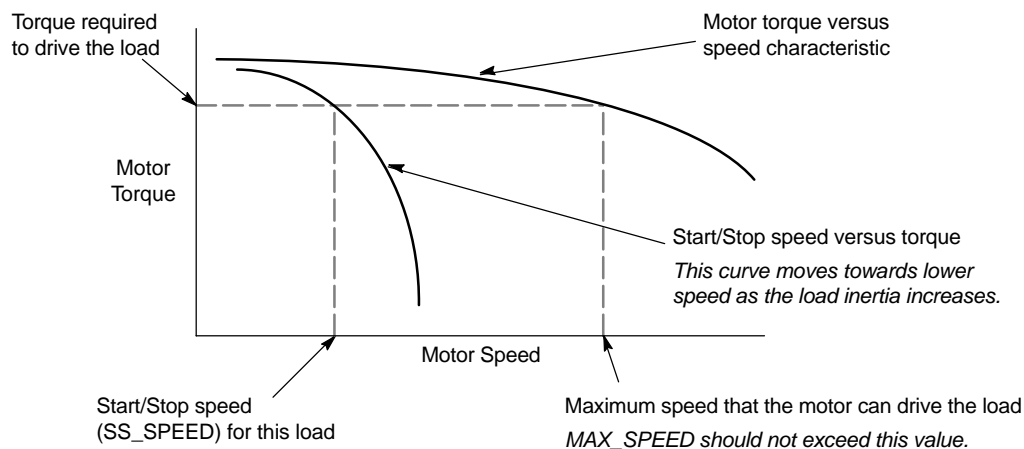

Figure 9-6 Typical Torque-Speed Curve for a Motor

Entering the Jog Parameters

The Jog command is used to manually move the tool to a desired location. Using the Position Control wizard, you specify the following Jog parameters values:

- JOG_SPEED:** The JOG_SPEED (Jog speed for the motor) is the maximum speed that can be obtained while the JOG command remains active.
- JOG_INCREMENT:** Distance that the tool is moved by a momentary JOG command.

Figure 9-7 shows the operation of the Jog command. When the Position module receives a Jog command, it starts a timer. If the Jog command is terminated before 0.5 seconds has elapsed, the Position module moves the tool the amount specified in the JOG_INCREMENT at the speed defined by SS_SPEED. If the Jog command is still active when the 0.5 seconds have elapsed, the Position module accelerates to the JOG_SPEED. Motion continues until the Jog command is terminated. The Position module then performs a decelerated stop. You can enable the Jog command either from the EM 253 control panel or with a position instruction.

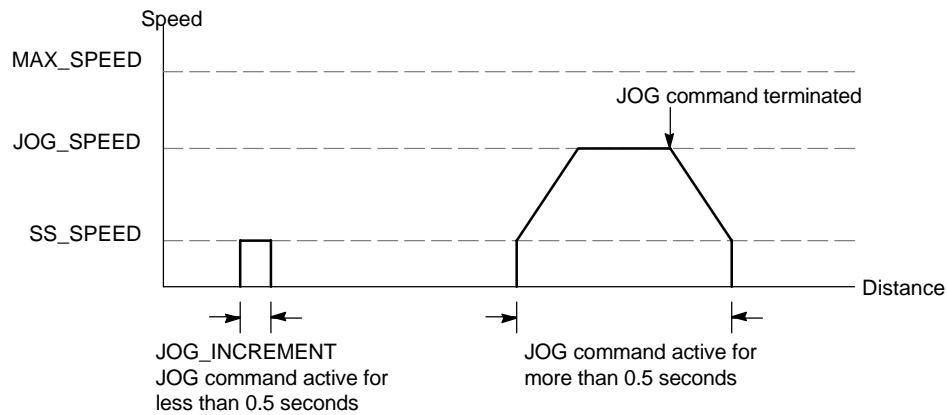

Figure 9-7 Representation of a JOG Operation

Entering the Acceleration and Deceleration Times

As part of the configuration for the Position module, you set the acceleration and deceleration times. The default setting for both the acceleration time and the deceleration time is 1 second. Typically, motors can work with less than 1 second. You specify the following times in milliseconds:

- ACCEL_TIME:** Time required for the motor to accelerate from SS_SPEED to MAX_SPEED. Default = 1000 ms
- DECEL_TIME:** Time required for the motor to decelerate from MAX_SPEED to SS_SPEED. Default = 1000 ms

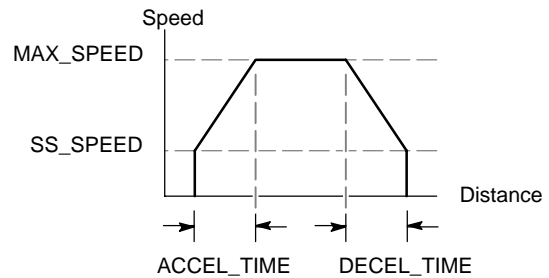

Figure 9-8 Acceleration and Deceleration Times



Tip

Motor acceleration and deceleration times are determined by trial and error. You should start by entering a larger value with the Position Control wizard. As you test your application, you can then use the EM 253 Control Panel to adjust the values as required. Optimize these settings for the application by gradually reducing the times until the motor starts to stall.

Entering the Jerk Time

Jerk compensation provides smoother position control by reducing the jerk (rate of change) in acceleration and deceleration parts of the motion profile. See Figure 9-9. Reducing jerk improves position tracking performance. Jerk compensation is also known as “S curve profiling.” Jerk compensation can only be applied to simple one-step profiles. This compensation is applied equally to the beginning and ending portions of both the acceleration and deceleration curve. Jerk compensation is not applied to the initial and final step between zero speed and SS_SPEED.

You specify the jerk compensation by entering a time value (JERK_TIME). This is the time required for acceleration to change from zero to the maximum acceleration defined by MAX_SPEED, SS_SPEED, and ACCEL_TIME, or equivalently for DECEL_TIME. A longer jerk time yields smoother operation with a smaller increase in total cycle time than would be obtained by simply increasing the ACCEL_TIME and DECEL_TIME. A value of zero indicates that no compensation should be applied.

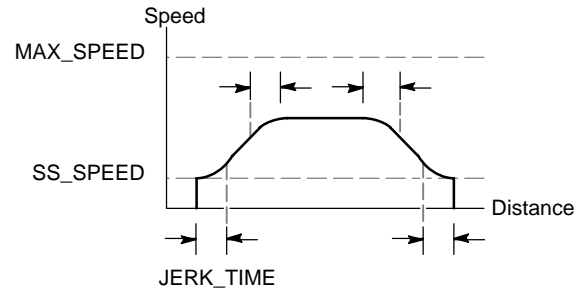

(Default = 0 ms)

Figure 9-9 Jerk Compensation



Tip

A good first value for JERK_TIME is 40% of ACCEL_TIME.

Configuring a Reference Point and the Seek Parameters

If your application specifies movements from an absolute position, you must establish a zero position that fixes the position measurements to a known point on the physical system. One method is to provide a reference point (RP) on your physical system. The Position module provides an external reference point switch (RPS) input that is used when seeking the RP.

You can configure the Reference Point Seek (RP seek) parameters that control how your motion application seek the RP. The RP can be centered in the RPS Active zone, the RP can be located on the edge of the RPS Active zone, or the RP can be located a specified number of zero pulse (ZP) input transitions from the edge of the RPS Active zone. To configure the RP, you enter the following information:

- You specify the RP seek speeds for the motor:
 - RP_FAST is the initial speed the module uses when performing an RP seek command. Typically, the RP_FAST value is approximately 2/3 of the MAX_SPEED value.
 - RP_SLOW is the speed of the final approach to the RP. A slower speed is used on approach to the RP, so as not to miss it. Typically, the RP_SLOW value is the SS_SPEED value.
- You specify the initial seek direction (RP_SEEK_DIR) and the final approach direction (RP_APPR_DIR) for the RP Seek. These directions are specified as negative or positive.
 - RP_SEEK_DIR is the initial direction for the RP seek operation. Typically, this is the direction from the work zone to the vicinity of the RP. Limit switches play an important role in defining the region that is searched for the RP. When performing a RP seek operation, encountering a limit switch can result in a reversal of the direction, which allows the search to continue. (Default = Negative)
 - RP_APPR_DIR is the direction of the final approach to the RP. To reduce backlash and provide more accuracy, RP_APPR_DIR moves in the same direction as the normal work cycle. (Default = Positive)

The Position Control wizard provides advanced reference point options that allow you to specify a RP offset (RP_OFFSET), which is the distance from the RP to the zero position. See Figure 9-10. The RP is identified by a method of locating an exact position with respect to the RPS. To configure the RP offset, you enter the following values:

- RP_OFFSET: Distance from the RP to the zero position of the physical measuring system. Default = 0
- Backlash compensation: Distance that the motor must move to eliminate the slack (backlash) in the system on a direction change. Backlash compensation is always a positive value. Default = 0

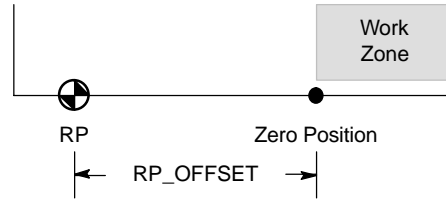

Figure 9-10 Relationship Between RP and Zero Position

Configuring the RP Seek Sequence

You can configure the sequence that the Position module uses to search for the reference point. Figure 9-11 shows a simplified diagram of the default RP seek sequence. You can select the following options for the RP search sequence:

- RP Seek mode 0: Does not perform a RP seek sequence
- RP Seek mode 1: The RP is where the RPS input goes active on the approach from the work zone side. (Default)
- RP Seek mode 2: The RP is centered within the active region of the RPS input.
- RP Seek mode 3: The RP is located outside the active region of the RPS input. RP_Z_CNT specifies how many ZP (Zero Pulse) input counts should be received after the RPS becomes inactive.
- RP Seek mode 4: The RP is generally within the active region of the RPS input. RP_Z_CNT specifies how many ZP (Zero Pulse) input counts should be received after the RPS becomes active.

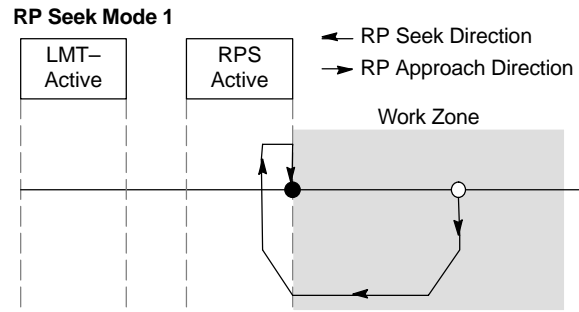

Figure 9-11 Default RP Search Sequence (Simplified)



Tip

The RPS Active region (which is the distance that the RPS input remains active) must be greater than the distance required to decelerate from the RP_FAST speed to the RP_SLOW speed. If the distance is too short, the Position module generates an error.

For more information about the different RP seek sequences for the Position module, see Figures 9-14 through 9-17 on pages 254 through 255.

Configuring the Motion Profiles for the Position Module

A profile is a pre-defined motion description consisting of one or more speeds of movement that effect a movement from a starting point to an ending point. You do not have to define a profile in order to use the module. The Position Control wizard provides an instruction subroutine (POSx_GOTO) for you to use to control moves.

- Number of profiles: You can select up to a maximum of 25 profiles.
- Address for the command byte: You must enter the output (Q) memory address of the command byte for the Position module. See Figure 4-10 on page 31 for a description of the I/O numbering.
- Address for the configuration/profile table: You must enter the starting memory address for the configuration/profile table that stores the configuration data for the Position module and the data for all of the profiles. The configuration data for the Position module requires 92 bytes of V memory, and each profile requires 34 bytes of V memory. For example, the amount of memory required for the configuration/profile table for a Position module with one profile is 126 bytes of V memory.

The Position Control wizard can suggest an unused V memory block address of the correct size.

Defining the Motion Profile

The Position Control wizard provides a Motion Profile Definition where you define each motion profile for your application. For each profile, you select the operating mode and define the specifics of each individual step for the profile. The Position Control wizard also allows you to define a symbolic name for each profile by simply entering the symbol name as you define the profile. After you have finished configuring the profile, you can save to configuration and print a copy of the parameters.

Selecting the Mode of Operation for the Profile

You configure the profile according to the mode of operation, either an absolute position, a relative position, a single-speed continuous rotation, or a two-speed continuous rotation. Figure 9-12 shows the different modes of operation.

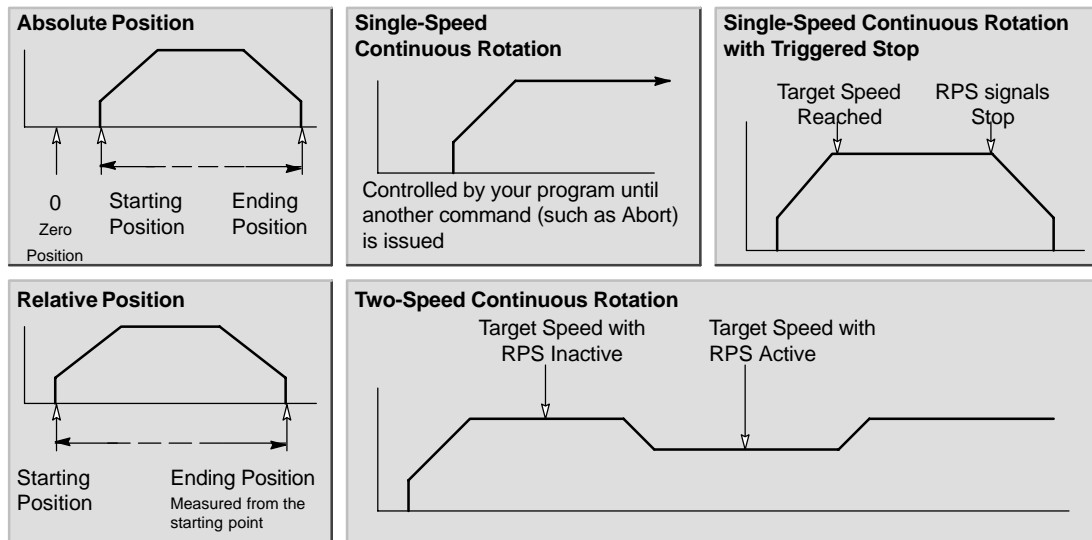

Figure 9-12 Mode Selections for the Position Module

Creating the Steps for the Profile

A step is a fixed distance that a tool moves, including the distance covered during acceleration and deceleration times. Each profile can have up to 4 individual steps.

You specify the target speed and ending position for each step. If you have more than one step, simply click the New Step button and enter the information for each step of the profile.

Figure 9-13 shows four possible profiles; however, there are other possible combinations.

By simply clicking the Plot Step button, you can view a graphical representation of the step, as calculated by the Position Control wizard. This allows you to easily and interactively review and edit each step.

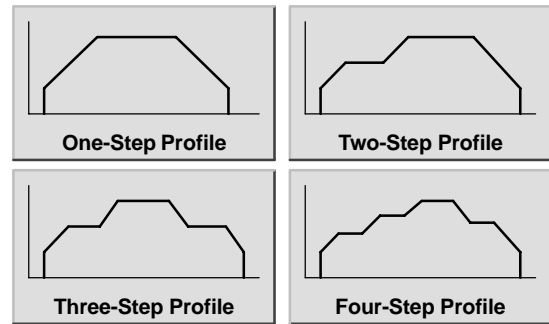

Figure 9-13 Sample Motion Profiles

Finishing the Configuration for the Position Module

After you have configured the operation of the Position module, you simply click Finish, and the Position Control wizard performs the following tasks:

- Inserts the module configuration and profile table into the data block for your S7-200 program
- Creates a global symbol table for the motion parameters
- Adds the motion instruction subroutines into the project program block for you to use in your application

You can run the Position Control wizard again in order to modify any configuration or profile information.



Tip

Because the Position Control wizard makes changes to the program block, the data block and the system block, be sure to download all three blocks to the S7-200 CPU. Otherwise, the Position module might not have all the program components that it needs for proper operation.

Understanding the RP Seek Modes Supported by the Position Module

The following figures provide diagrams of the different options for each RP seek mode.

- Figure 9-14 shows two of the options for RP seek mode 1. This mode locates the RP where the RPS input goes active on the approach from the work zone side.
- Figure 9-15 shows two of the options for RP seek mode 2. This mode locates the RP in the center within the active region of the RPS input.
- Figure 9-16 shows two of the options for RP seek mode 3. This mode locates the RP a specified number of zero pulses (ZP) outside the active region of the RPS input.
- Figure 9-17 shows two of the options for RP seek mode 4. This mode locates the RP a specified number of zero pulses (ZP) within the active region of the RPS input.

For each mode, there are four combinations of RP Seek direction and RP Approach direction. (Only two of the combinations are shown.) These combinations determine the pattern for the RP seek operation. For each of the combinations, there are also four different starting points:

The work zones for each diagram have been located so that moving from the reference point to the work zone requires movement in the same direction as the RP Approach Direction. By selecting the location of the work zone in this way, all the backlash of the mechanical gearing system is removed for the first move to the work zone after a reference point seek.

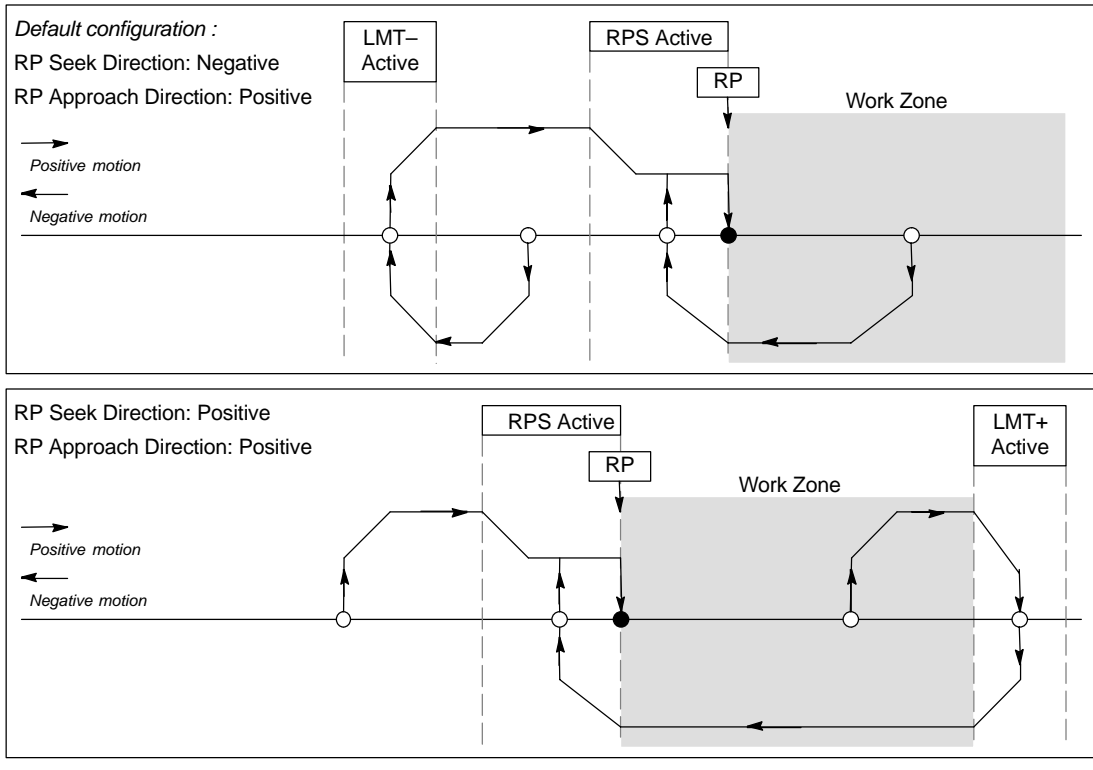

Figure 9-14 RP Seek Mode 1

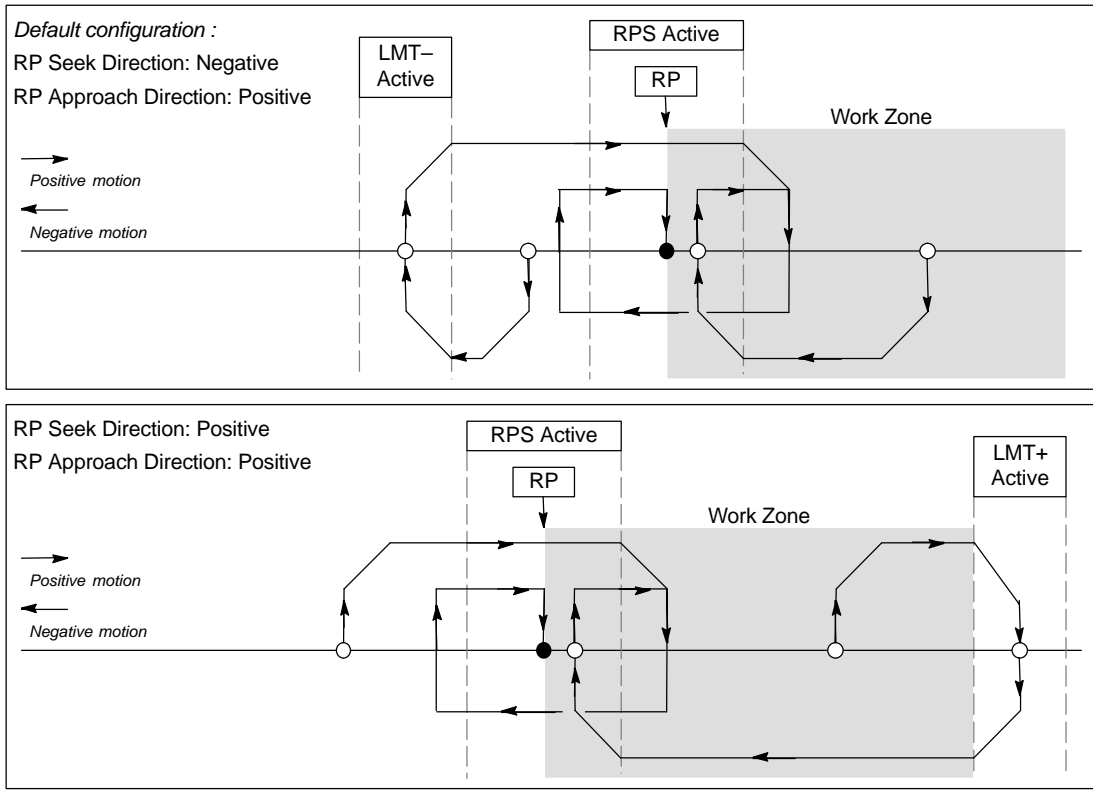

Figure 9-15 RP Seek: Mode 2

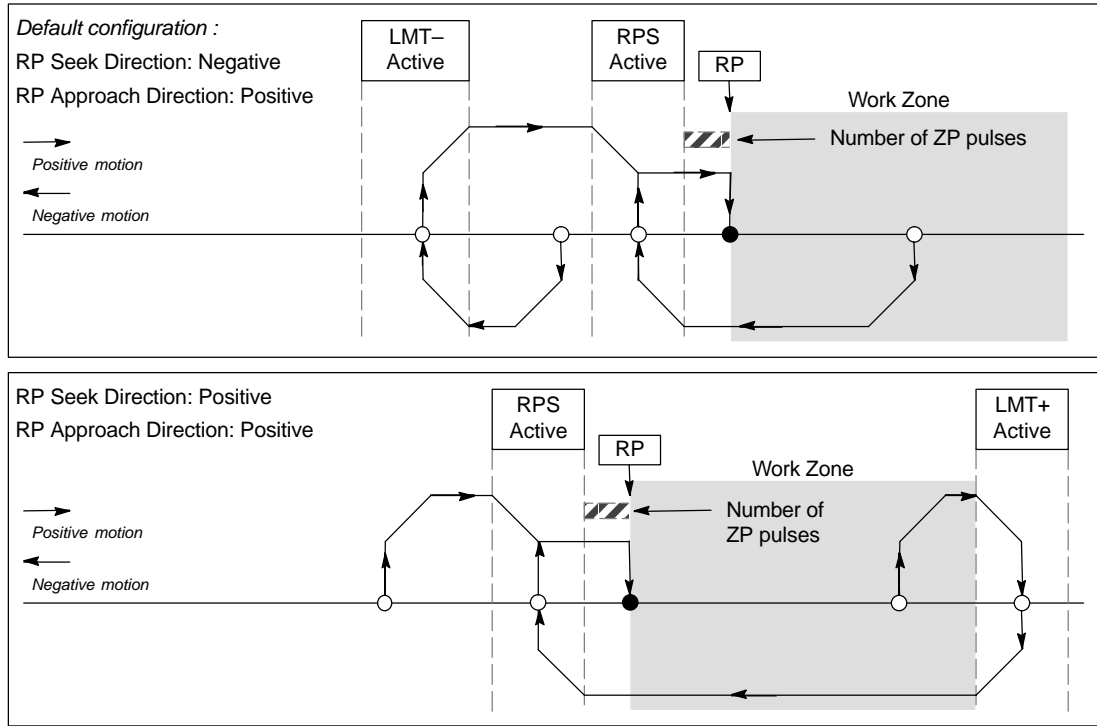

Figure 9-16 RP Seek: Mode 3

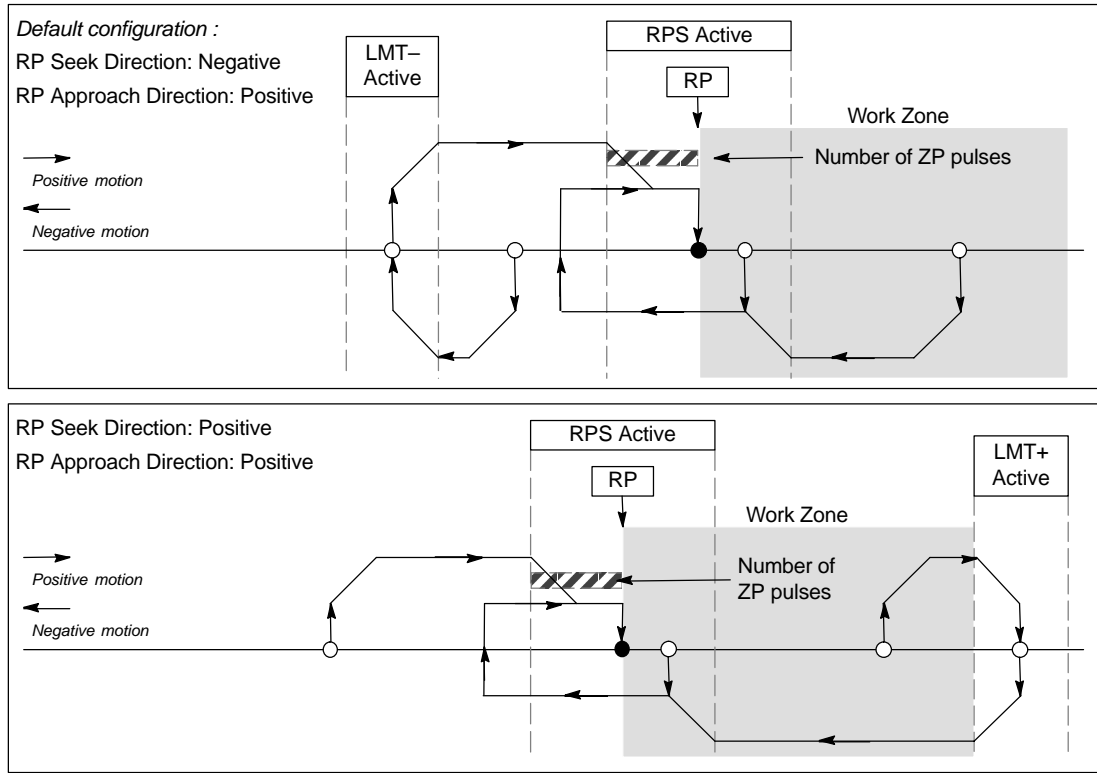

Figure 9-17 RP Seek: Mode 4

Selecting the Location of the Work Zone to Eliminate Backlash

Figure 9-18 shows the work zone in relationship to the reference point (RP), the RPS Active zone, and the limit switches (LMT+ and LMT-) for an approach direction that eliminates the backlash. The second part of the illustration places the work zone so that the backlash is not eliminated. Figure 9-18 shows RP seek mode 3. A similar placement of the work zone is possible, although not recommended, for each of the search sequences for each of the other RP seek modes.

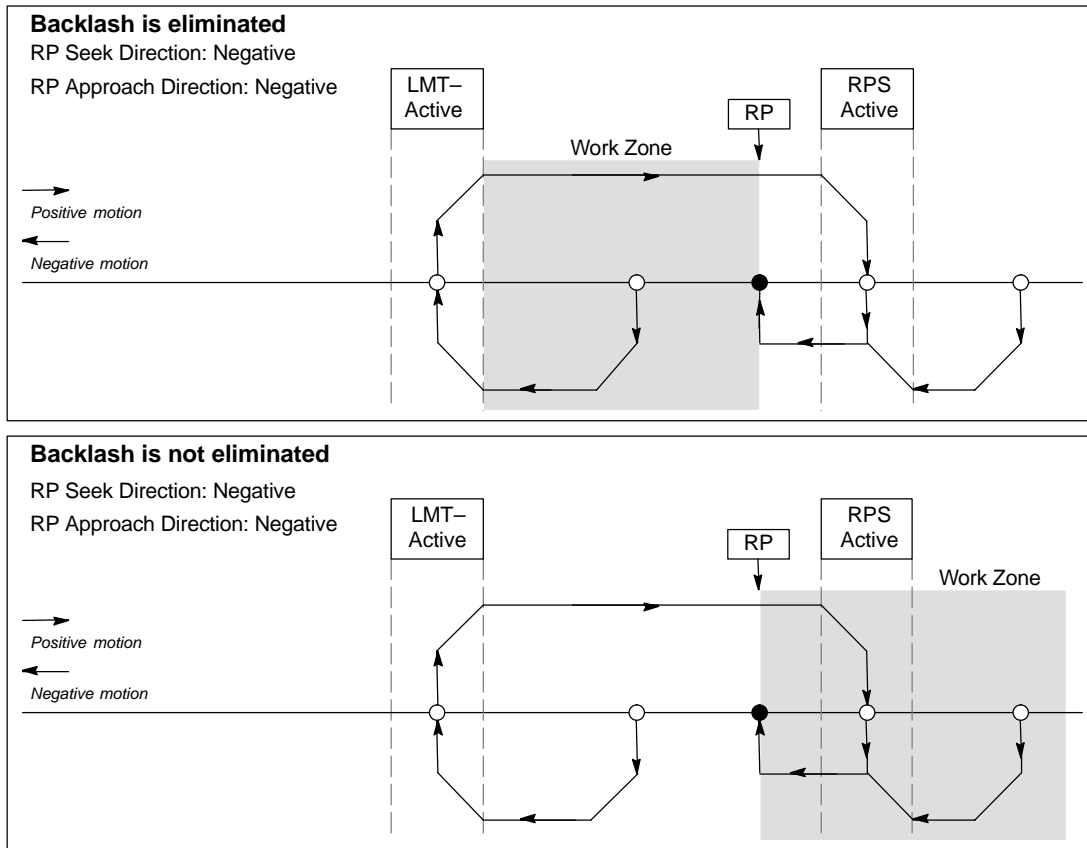

Figure 9-18 Placement of the Work Zone with and without the Elimination of Backlash

Position Instructions Created by the Position Control Wizard

The Position Control wizard makes controlling the Position module easier by creating unique instruction subroutines based on the position of the module and configuration options you selected. Each position instruction is prefixed with a "POSx_" where x is the module location. Because each position instruction is a subroutine, the 11 position instructions use 11 subroutines.



Tip

The position instructions increase the amount of memory required for your program by up to 1700 bytes. You can delete unused position instructions to reduce the amount of memory required. To restore a deleted position instruction, simply run the Position Control wizard again.

Guidelines for Using the Position Instructions

You must ensure that only one position instruction is active at a time.

You can execute the POSx_RUN and POSx_GOTO from an interrupt routine. However, it is very important that you do not attempt to start an instruction in an interrupt routine if the module is busy processing another command. If you start an instruction in an interrupt routine, then you can use the outputs of the POSx_CTRL instruction to monitor when the Position module has completed the movement.

The Position Control wizard automatically configures the values for the speed parameters (Speed and C_Speed) and the position parameters (Pos or C_Pos) according to the measurement system that you selected. For pulses, these parameters are DINT values. For engineering units, the parameters are REAL values for the type of unit that you selected. For example: selecting centimeters (cm) stores the position parameters as REAL values in centimeters and stores the speed parameters as REAL values in centimeters per second (cm/sec).

The following position instructions are required for specific position control tasks:

- Insert the POSx_CTRL instruction in your program and use the SM0.0 contact to execute it every scan.
- To specify motion to an absolute position, you must first use either an POSx_RSEEK or a POSx_LDPOS instruction to establish the zero position.
- To move to a specific location, based on inputs from your program, use the POSx_GOTO instruction.
- To run the motion profiles you configured with the Position Control wizard, use the POSx_RUN instruction.

The other position instructions are optional.

POSx_CTRL Instruction

The POSx_CTRL instruction (Control) enables and initializes the Position module by automatically commanding the Position module to load the configuration/profile table each time the S7-200 changes to RUN mode.

Use this instruction only once in your project, and ensure that your program calls this instruction every scan. Use SM0.0 (Always On) as the input for the EN parameter.

The EN parameter must be on to enable the other position instructions to send commands to the Position module. If the EN parameter turns off, then the Position module aborts any command that is in progress.

The output parameters of the POSx_CTRL instruction provide the current status of the Position module.

The Done parameter turns on when the Position module completes any instruction.

The Error parameter contains the result of this instruction. See Table 9-13 on page 276 for definitions of the error codes.

The C_Pos parameter is the current position of the module. Based on the units of measurement, the value is either a number of pulses (DINT) or the number of engineering units (REAL).

The C_Speed parameter provides the current speed of the module. If you configured the measurement system for the Position module for pulses, C_Speed is a DINT value containing the number of pulses/second. If you configured the measurement system for engineering units, C_Speed is a REAL value containing the selected engineering units/second (REAL).

The C_Dir parameter indicates the current direction of the motor.

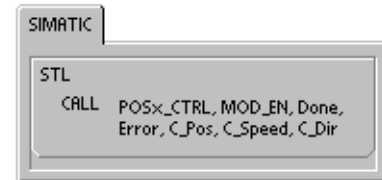
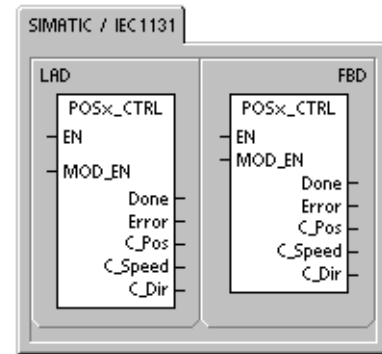

Table 9-2 Parameters for the POSx_CTRL Instruction

Inputs/Outputs	Data Type	Operands
MOD_EN	BOOL	I, Q, V, M, SM, S, T, C, L, Power Flow
Done, C_Dir	BOOL	I, Q, V, M, SM, S, T, C, L
Error	BYTE	IB, QB, VB, MB, SMB, SB, LB, AC, *VD, *AC, *LD
C_Pos, C_Speed	DINT, REAL	ID, QD, VD, MD, SMD, SD, LD, AC, *VD, *AC, *LD



Tip

The Position module reads the configuration/profile table only at power-up or when commanded to load the configuration.

- If you use the Position Control wizard to modify the configuration, then the POSx_CTRL instruction automatically commands the Position module to load the configuration/profile table every time the S7-200 CPU changes to RUN mode.
- If you use the EM 253 Control Panel to modify the configuration, clicking the Update Configuration button commands the Position module to load the new configuration/profile table.
- If you use another method to modify the configuration, then you must also issue a Reload the Configuration command to the Position module to load the configuration/profile table. Otherwise, the Position module continues to use the old configuration/profile table.

POSx_MAN Instruction

The POSx_MAN instruction (Manual Mode) puts the Position module into manual mode. This allows the motor to be run at different speeds or to be jogged in a positive or negative direction. While the POSx_MAN instruction is enabled, only the POSx_CTRL and POSx_DIS instructions are allowed.

You can enable only one of the RUN, JOG_P, or JOG_N inputs at a time.

Enabling the RUN (Run/Stop) parameter commands to the Position module to accelerate to the specified speed (Speed parameter) and direction (Dir parameter). You can change the value for the Speed parameter while the motor is running, but the Dir parameter must remain constant. Disabling the RUN parameter commands the Position module to decelerate until the motor comes to a stop.

Enabling the JOG_P (Jog Positive Rotation) or the JOG_N (Jog Negative Rotation) parameter commands the Position module to jog in either a positive or negative direction. If the JOG_P or JOG_N parameter remains enabled for less than 0.5 seconds, the Position module issues pulses to travel the distance specified in JOG_INCREMENT. If the JOG_P or JOG_N parameter remains enabled for 0.5 seconds or longer, the motion module begins to accelerate to the specified JOG_SPEED.

The Speed parameter determines the speed when RUN is enabled. If you configured the measuring system of the Position module for pulses, the speed is a DINT value for pulses/second. If you configured the measuring system of the Position module for engineering units, the speed is a REAL value for units/second. You can change this parameter while the motor is running.

The Dir parameter determines the direction to move when RUN is enabled. You cannot change this value when the RUN parameter is enabled.

The Error parameter contains the result of this instruction. See Table 9-13 on page 276 for definitions of the error codes.

The C_Pos parameter contains the current position of the module. Based on the units of measurement selected, the value is either a number of pulses (DINT) or the number of engineering units (REAL).

The C_Speed parameter contains the current speed of the module. Based on the units of measurement selected, the value is either the number of pulses/second (DINT) or the engineering units/second (REAL).

The C_Dir parameter indicates the current direction of the motor.

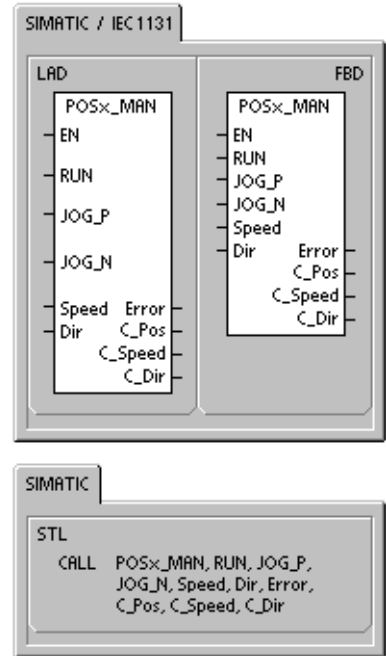

Table 9-3 Parameters for the POSx_MAN Instruction

Inputs/Outputs	Data Type	Operands
RUN, JOG_P, JOG_N	BOOL	I, Q, V, M, SM, S, T, C, L, Power Flow
Speed	DINT, REAL	ID, QD, VD, MD, SMD, SD, LD, AC, *VD, *AC, *LD, Constant
Dir, C_Dir	BOOL	I, Q, V, M, SM, S, T, C, L
Error	BYTE	IB, QB, VB, MB, SMB, SB, LB, AC, *VD, *AC, *LD
C_Pos, C_Speed	DINT, REAL	ID, QD, VD, MD, SMD, SD, LD, AC, *VD, *AC, *LD

POSx_GOTO Instruction

The POSx_GOTO instruction commands the Position Module to go to a desired location.

Turning on the EN bit enables the instruction. Ensure that the EN bit stays on until the DONE bit signals that the execution of the instruction has completed.

Turning on the START parameter sends a GOTO command to the Position module. For each scan when the START parameter is on and the Position module is not currently busy, the instruction sends a GOTO command to the Position module. To ensure that only one GOTO command is sent, use an edge detection element to pulse the START parameter on.

The Pos parameter contains a value that signifies either the location to move (for an absolute move) or the distance to move (for a relative move). Based on the units of measurement selected, the value is either a number of pulses (DINT) or the engineering units (REAL).

The Speed parameter determines the maximum speed for this movement. Based on the units of measurement, the value is either a number of pulses/second (DINT) or the engineering units/second (REAL).

The Mode parameter selects the type of move:

- 0 – Absolute position
- 1 – Relative position
- 2 – Single-speed, continuous positive rotation
- 3 – Single-speed, continuous negative rotation

The Done parameter turns on when the Position module completes this instruction.

The Error parameter contains the result of this instruction. See Table 9-13 on page 276 for definitions of the error codes.

The C_Pos parameter contains current position of the module. Based on the units of measurement, the value is either a number of pulses (DINT) or the number of engineering units (REAL).

The C_Speed parameter contains the current speed of the module. Based on the units of measurement, the value is either a number of pulses/second (DINT) or the engineering units/second (REAL).

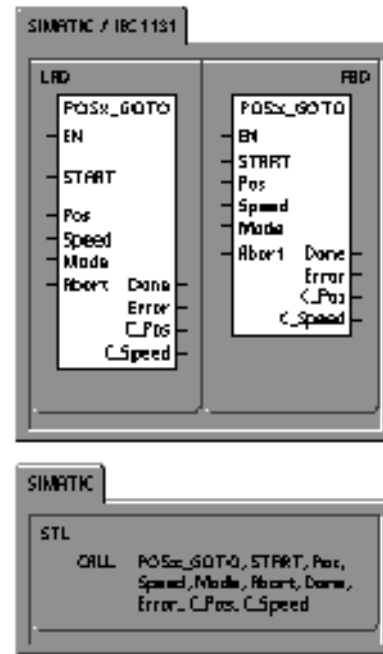

Table 9-4 Parameters for the POSx_GOTO Instruction

Inputs/Outputs	Data Type	Operands
START	BOOL	I, Q, V, M, SM, S, T, C, L, Power Flow
Pos, Speed	DINT, REAL	ID, QD, VD, MD, SMD, SD, LD, AC, *VD, *AC, *LD, Constant
Mode	BYTE	IB, QB, VB, MB, SMB, SB, LB, AC, *VD, *AC, *LD, Constant
Abort, Done	BOOL	I, Q, V, M, SM, S, T, C, L
Error	BYTE	IB, QB, VB, MB, SMB, SB, LB, AC, *VD, *AC, *LD
C_Pos, C_Speed	DINT, REAL	ID, QD, VD, MD, SMD, SD, LD, AC, *VD, *AC, *LD

POSx_RUN Instruction

The POSx_RUN instruction (Run Profile) commands the Position module to execute the motion operation in a specific profile stored in the configuration/profile table.

Turning on the EN bit enables the instruction. Ensure that the EN bit stays on until the Done bit signals that the execution of the instruction has completed.

Turning on the START parameter sends a RUN command to the Position module. For each scan when the START parameter is on and the Position module is not currently busy, the instruction sends a RUN command to the Position module. To ensure that only one command is sent, use an edge detection element to pulse the START parameter on.

The Profile parameter contains the number or the symbolic name for the motion profile. You can also select the advanced motion commands (118 to 127). For information about the motion commands, see Table 9-19 on page 284.

Turning on the Abort parameter commands to the Position module to stop the current profile and decelerate until the motor comes to a stop.

The Done parameter turns on when the module completes this instruction.

The Error parameter contains the result of this instruction. See Table 9-13 on page 276 for definitions of the error codes.

The C_Profile parameter contains the profile currently being executed by the Position module.

The C_Step parameter contains the step of the profile currently being executed.

The C_Pos parameter contains the current position of the module. Based on the units of measurement, the value is either a number of pulses (DINT) or the number of engineering units (REAL).

The C_Speed parameter contains the current speed of the module. Based on the units of measurement, the value is either a number of pulses/second (DINT) or the engineering units/second (REAL).

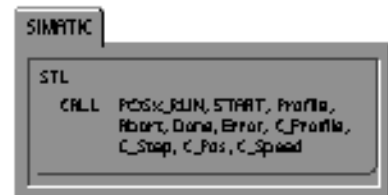
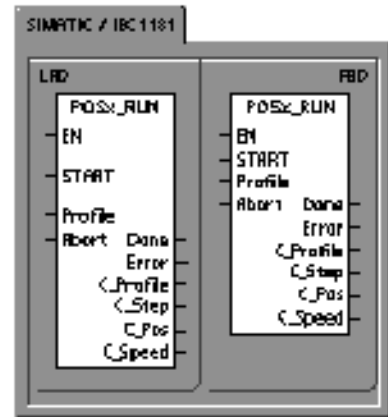

Table 9-5 Parameters for the POSx_RUN Instruction

Inputs/Outputs	Data Type	Operands
START	BOOL	I, Q, V, M, SM, S, T, C, L, Power Flow
Profile	BYTE	IB, QB, VB, MB, SMB, SB, LB, AC, *VD, *AC, *LD, Constant
Abort, Done	BOOL	I, Q, V, M, SM, S, T, C, L
Error, C_Profile, C_Step	BYTE	IB, QB, VB, MB, SMB, SB, LB, AC, *VD, *AC, *LD
C_Pos, C_Speed	DINT, REAL	ID, QD, VD, MD, SMD, SD, LD, AC, *VD, *AC, *LD

POSx_RSEEK Instruction

The POSx_RSEEK instruction (Seek Reference Point Position) initiates a reference point seek operation, using the search method in the configuration/profile table. When the Position module locates the reference point and motion has stopped, the Position module loads the RP_OFFSET parameter value into the current position and generates a 50-millisecond pulse on the CLR output.

The default value for RP_OFFSET is 0. You can use the Position Control wizard, the EM253 Control Panel, or the POSx_LDOFF (Load Offset) instruction to change the RP_OFFSET value.

Turning on the EN bit enables the instruction. Ensure that the EN bit stays on until the Done bit signals that the execution of the instruction has completed.

Turning on the START parameter sends a RSEEK command to the Position module. For each scan when the START parameter is on and the Position module is not currently busy, the instruction sends a RSEEK command to the Position module. To ensure that only one command is sent, use an edge detection element to pulse the START parameter on.

The Done parameter turns on when the module completes this instruction.

The Error parameter contains the result of this instruction. See Table 9-13 on page 276 for definitions of the error codes.

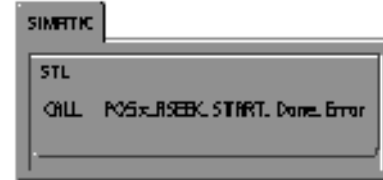
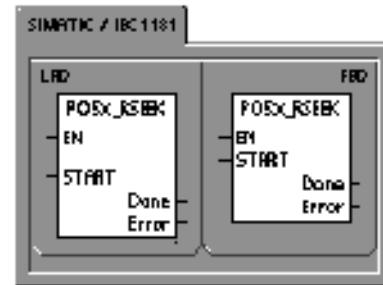

Table 9-6 Parameters for the POSx_RSEEK Instruction

Inputs/Outputs	Data Type	Operands
START	BOOL	I, Q, V, M, SM, S, T, C, L, Power Flow
Done	BOOL	I, Q, V, M, SM, S, T, C, L
Error	BYTE	IB, QB, VB, MB, SMB, SB, LB, AC, *VD, *AC, *LD

POSx_LDOFF Instruction

The POSx_LDOFF instruction (Load Reference Point Offset) establishes a new zero position that is at a different location from the reference point position.

Before executing this instruction, you must first determine the position of the reference point. You must also move the machine to the starting position. When the instruction sends the LDOFF command, the Position module computes the offset between the starting position (the current position) and the reference point position. The Position module then stores the computed offset to the RP_OFFSET parameter and sets the current position to 0. This establishes the starting position as the zero position.

In the event that the motor loses track of its position (such as on loss of power or if the motor is repositioned manually), you can use the POSx_RSEEK instruction to re-establish the zero position automatically.

Turning on the EN bit enables the instruction. Ensure that the EN bit stays on until the Done bit signals that the execution of the instruction has completed.

Turning on the START parameter sends a LDOFF command to the Position module. For each scan when the START parameter is on and the Position module is not currently busy, the instruction sends a LDOFF command to the Position module. To ensure that only one command is sent, use an edge detection element to pulse the START parameter on.

The Done parameter turns on when the module completes this instruction.

The Error parameter contains the result of this instruction. See Table 9-13 on page 276 for definitions of the error codes.

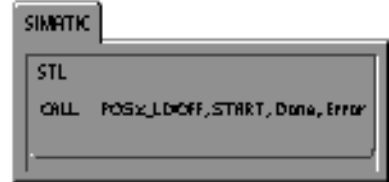
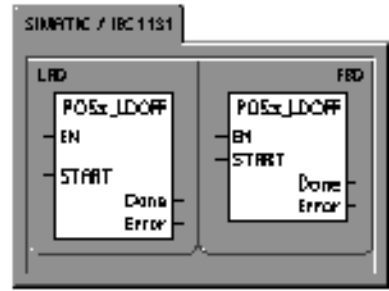

Table 9-7 Parameters for the POSx_LDOFF Instruction

Inputs/Outputs	Data Type	Operands
START	BOOL	I, Q, V, M, SM, S, T, C, L, Power Flow
Done	BOOL	I, Q, V, M, SM, S, T, C, L
Error	BYTE	IB, QB, VB, MB, SMB, SB, LB, AC, *VD, *AC, *LD

POSx_LDPOS Instruction

The POSx_LDPOS instruction (Load Position) changes the current position value in the Position module to a new value. You can also use this instruction to establish a new zero position for any absolute move command.

Turning on the EN bit enables the instruction. Ensure that the EN bit stays on until the Done bit signals that the execution of the instruction has completed.

Turning on the START parameter sends a LDPOS command to the Position module. For each scan when the START parameter is on and the Position module is not currently busy, the instruction sends a LDPOS command to the Position module. To ensure that only one command is sent, use an edge detection element to pulse the START parameter on.

The New_Pos parameter provides the new value to replace the current position value that the Position module reports and uses for absolute moves. Based on the units of measurement, the value is either a number of pulses (DINT) or the engineering units (REAL).

The Done parameter turns on when the module completes this instruction.

The Error parameter contains the result of this instruction. See Table 9-13 on page 276 for definitions of the error codes.

The C_Pos parameter contains the current position of the module. Based on the units of measurement, the value is either a number of pulses (DINT) or the number of engineering units (REAL).



Table 9-8 Parameters for the POSx_LDPOS Instruction

Inputs/Outputs	Data Type	Operands
START	BOOL	I, Q, V, M, SM, S, T, C, L, Power Flow
New_Pos, C_Pos	DINT, REAL	ID, QD, VD, MD, SMD, SD, LD, AC, *VD, *AC, *LD
Done	BOOL	I, Q, V, M, SM, S, T, C, L
Error	BYTE	IB, QB, VB, MB, SMB, SB, LB, AC, *VD, *AC, *LD

POSx_SRATE Instruction

The POSx_SRATE instruction (Set Rate) commands the Position module to change the acceleration, deceleration, and jerk times.

Turning on the EN bit enables the instruction. Ensure that the EN bit stays on until the Done bit signals that the execution of the instruction has completed.

Turning on the START parameter copies the new time values to the configuration/profile table and sends a SRATE command to the Position module. For each scan when the START parameter is on and the Position module is not currently busy, the instruction sends a SRATE command to the Position module. To ensure that only one command is sent, use an edge detection element to pulse the START parameter on.

The ACCEL_Time, DECEL_Time, and JERK_Time parameters determine the new acceleration time, deceleration time, and jerk time in milliseconds (ms).

The Done parameter turns on when the module completes this instruction.

The Error parameter contains the result of this instruction. See Table 9-13 on page 276 for definitions of the error codes.

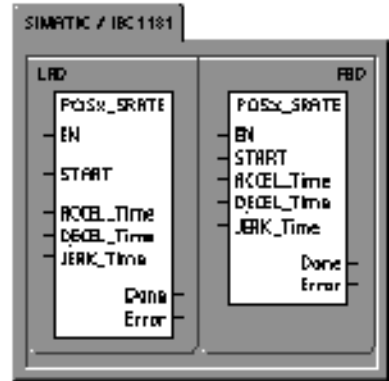

Table 9-9 Parameters for the POSx_SRATE Instruction

Inputs/Outputs	Data Type	Operands
START	BOOL	I, Q, V, M, SM, S, T, C, L
ACCEL_Time, DECEL_Time, JERK_Time	DINT	ID, QD, VD, MD, SMD, SD, LD, AC, *VD, *AC, *LD, Constant
Done	BOOL	I, Q, V, M, SM, S, T, C, L
Error	BYTE	IB, QB, VB, MB, SMB, SB, LB, AC, *VD, *AC, *LD

POSx_DIS Instruction

The POSx_DIS instruction turns the DIS output of the Position module on or off. This allows you to use the DIS output for disabling or enabling a motor controller. If you use the DIS output on the Position module, then this instruction can be called every scan or only when you need to change the value of the DIS output.

When the EN bit turns on to enable the instruction, the DIS_ON parameter controls the DIS output of the Position module. For more information about the DIS output, see Table 9-1 on page 244 or refer to the specifications for the Position module in Appendix A.

The Error parameter contains the result of this instruction. See Table 9-13 on page 276 for definitions of the error codes.

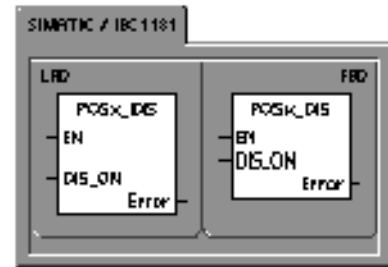

Table 9-10 Parameters for the POSx_DIS Instruction

Inputs/Outputs	Data Type	Operands
DIS_ON	BYTE	IB, QB, VB, MB, SMB, SB, LB, AC, *VD, *AC, *LD, Constant
Error	BYTE	IB, QB, VB, MB, SMB, SB, LB, AC, *VD, *AC, *LD

POSx_CLR Instruction

The POSx_CLR instruction (Pulse the CLR Output) commands the Position module to generate a 50-ms pulse on the CLR output.

Turning on the EN bit enables the instruction. Ensure that the EN bit stays on until the Done bit signals that the execution of the instruction has completed.

Turning on the START parameter sends a CLR command to the Position module. For each scan when the START parameter is on and the Position module is not currently busy, the instruction sends a CLR command to the Position module. To ensure that only one command is sent, use an edge detection element to pulse the START parameter on.

The Done parameter turns on when the module completes this instruction.

The Error parameter contains the result of this instruction. See Table 9-13 on page 276 for definitions of the error codes.

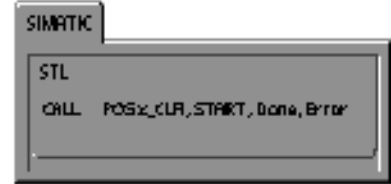
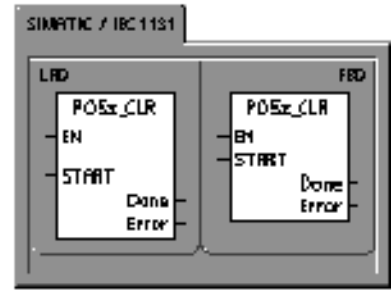

Table 9-11 Parameters for the POSx_CLR Instruction

Inputs/Outputs	Data Type	Operands
START	BOOL	I, Q, V, M, SM, S, T, C, L, Power Flow
Done	BOOL	I, Q, V, M, SM, S, T, C, L
Error	BYTE	IB, QB, VB, MB, SMB, SB, LB, AC, *VD, *AC, *LD

POSx_CFG Instruction

The POSx_CFG instruction (Reload Configuration) commands the Position module to read the configuration block from the location specified by the configuration/profile table pointer. The Position module then compares the new configuration with the existing configuration and performs any required setup changes or recalculations.

Turning on the EN bit enables the instruction. Ensure that the EN bit stays on until the Done bit signals that the execution of the instruction has completed.

Turning on the START parameter sends a CFG command to the Position module. For each scan when the START parameter is on and the Position module is not currently busy, the instruction sends a CFG command to the Position module. To ensure that only one command is sent, use an edge detection element to pulse the START parameter on.

The Done parameter turns on when the module completes this instruction.

The Error parameter contains the result of this instruction. See Table 9-13 on page 276 for definitions of the error codes.

Table 9-12 Parameters for the POSx_CFG Instruction

Inputs/Outputs	Data Type	Operands
START	BOOL	I, Q, V, M, SM, S, T, C, L, Power Flow
Done	BOOL	I, Q, V, M, SM, S, T, C, L
Error	BYTE	IB, QB, VB, MB, SMB, SB, LB, AC, *VD, *AC, *LD

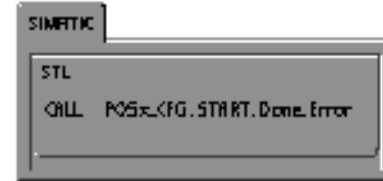
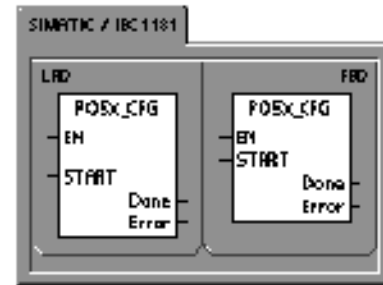

Sample Programs for the Position Module

The first sample program shows a simple relative move that uses the POSx_CTRL and POSx_GOTO instructions to perform a cut-to-length operation. This program does not require an RP seek mode or a motion profile, and the length can be measured in either pulses or engineering units. Enter the length (VD500) and target speed (VD504). When I0.0 (Start) turns on, the machine starts. When I0.1 (Stop) turns on, the machine finishes the current operation and stops. When I0.2 (E_Stop) turns on, the machine aborts any motion and immediately stops.

The second sample program provides an example of the POSx_CTRL, POSx_RUN, POSx_RSEEK, and POSx_MAN instructions. You must configure the RP seek mode and a motion profile.

Sample Program 1: Simple Relative Move (Cut to Length application)

	<pre> Network 1 //Control instruction (module in slot 0). LD SM0.0 = L60.0 LDN I0.2 = L63.7 LD L60.0 CALL POS0_CTRL, L63.7, M1.0, VB900, VD902, VD906, V910.0 Network 2 //Start puts machine into automatic mode LD I0.0 AN I0.2 EU S Q0.2, 1 S M0.1, 1 Network 3 //E_Stop: stops immediately and //turns off automatic mode. LD I0.2 R Q0.2, 1 Network 4 //Move to a certain point: //Enter the length to cut. //Enter the target speed into Speed. //Set the mode to 1 (Relative mode). LD Q0.2 = L60.0 LD M0.1 EU = L63.7 LD L60.0 CALL POS0_GOTO, L63.7, VD500, VD504, 1, I0.2, Q0.4, VB920, VD922, VD926 Network 5 //When in position, turn on the cutter //for 2 seconds to finish the cut. LD Q0.2 A Q0.4 TON T33, +200 AN T33 = Q0.3 </pre>
--	---

Sample Program 1: Simple Relative Move (Cut to Length application) , continued

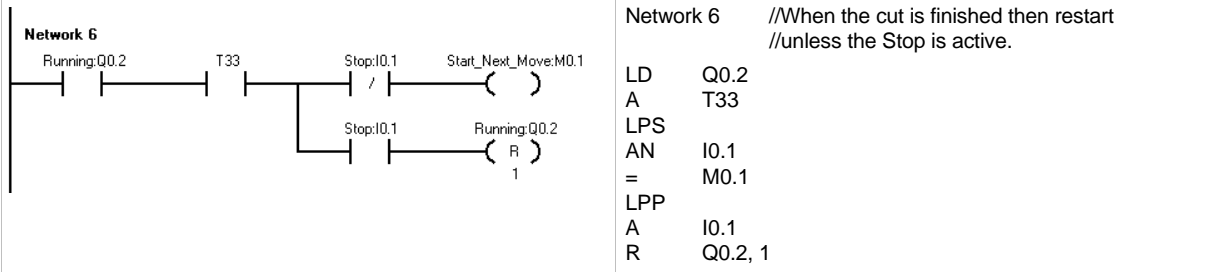

Sample Program 2: Program with POSx_CTRL, POSx_RUN, POSx_SEEK, and POSx_MAN

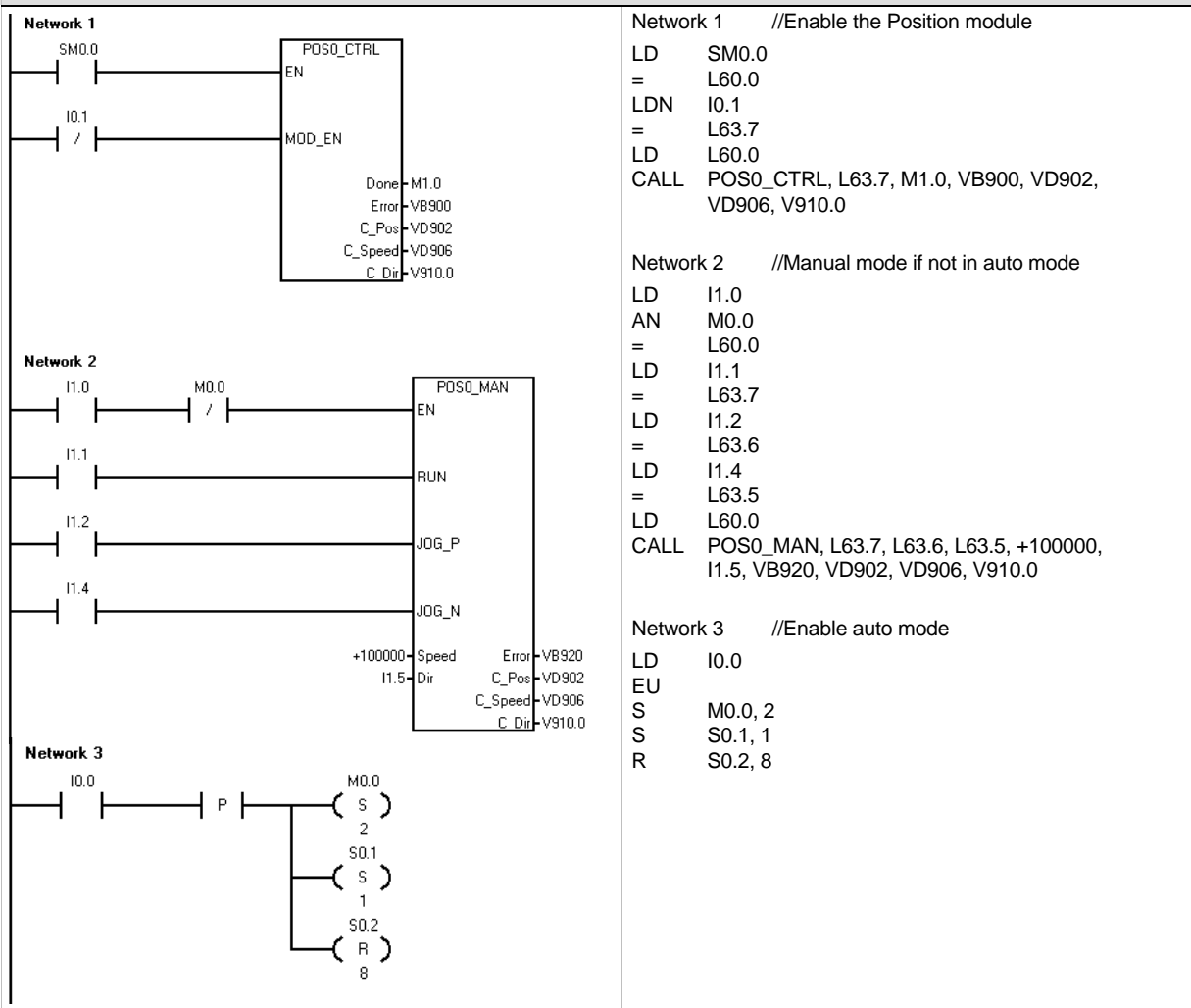

Sample Program 2: Program with POSx_CTRL, POSx_RUN, POSx_SEEK, and POSx_MAN, continued

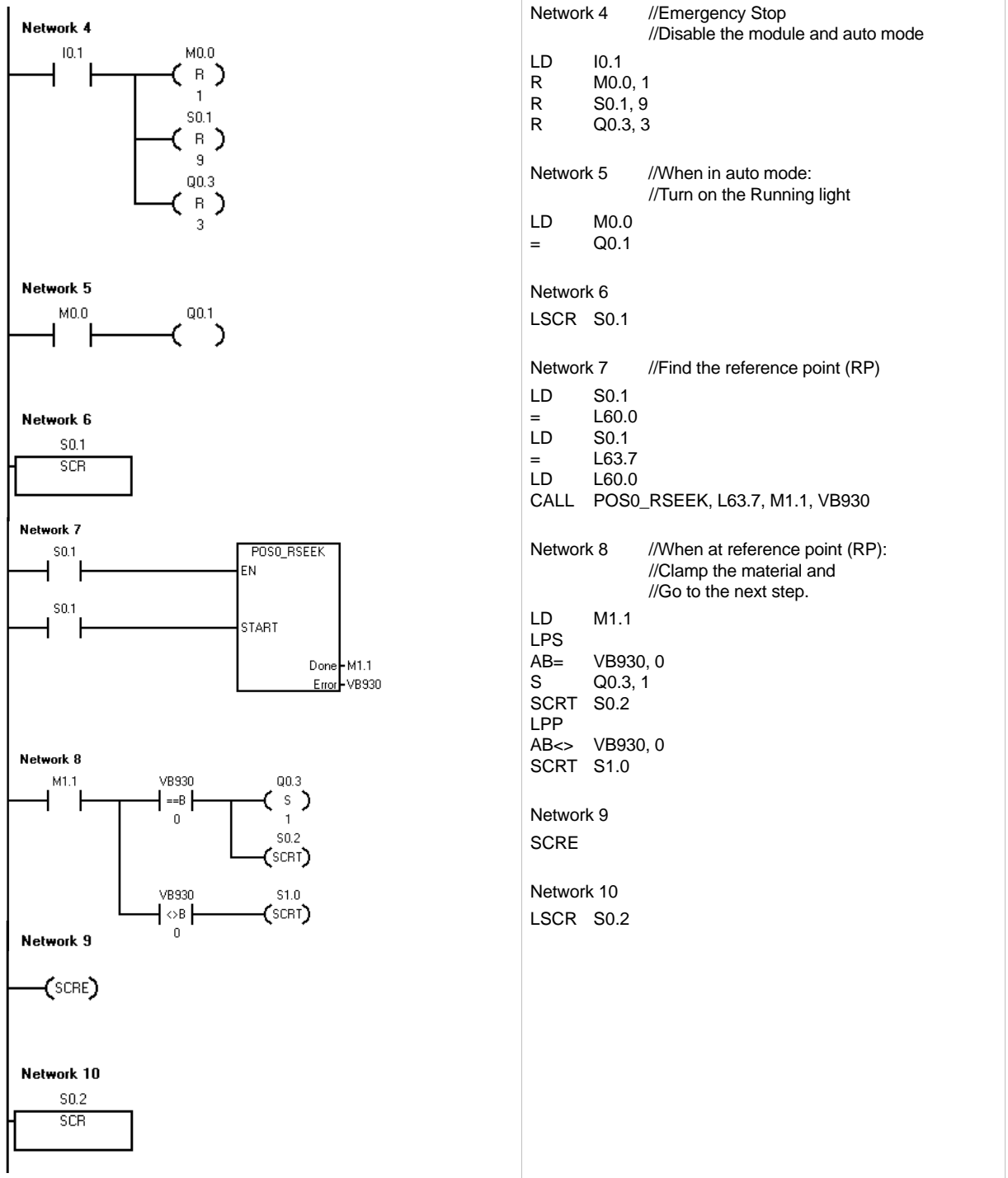

Sample Program 2: Program with POSx_CTRL, POSx_RUN, POSx_SEEK, and POSx_MAN, continued

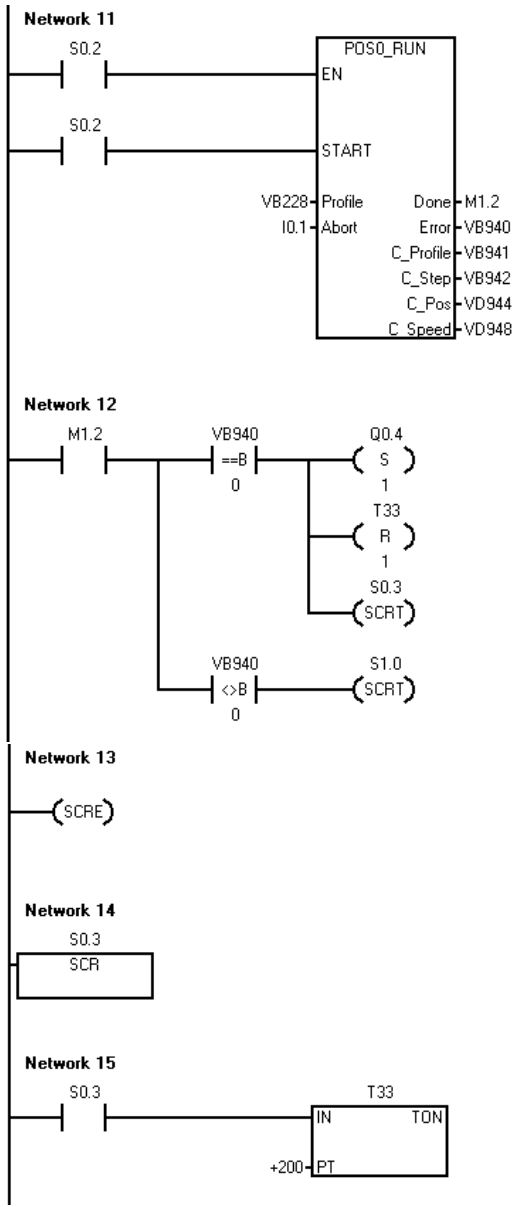

```

Network 11 //Use profile 1 to move into position.
LD S0.2
= L60.0
LD S0.2
= L63.7
LD L60.0
CALL POS0_RUN, L63.7, VB228, IO.1, M1.2, VB940,
VB941, VB942, VD944, VD948

Network 12 //When positioned, turn on the cutter
//and go to the next step.

LD M1.2
LPS
AB= VB940, 0
S Q0.4, 1
R T33, 1
SCRT S0.3
LPP
AB<> VB940, 0
SCRT S1.0

Network 13
SCR

Network 14 //Wait for the cut to finish
LSCR S0.3

Network 15
LD S0.3
TON T33, +200
    
```

Sample Program 2: Program with POSx_CTRL, POSx_RUN, POSx_SEEK, and POSx_MAN, continued

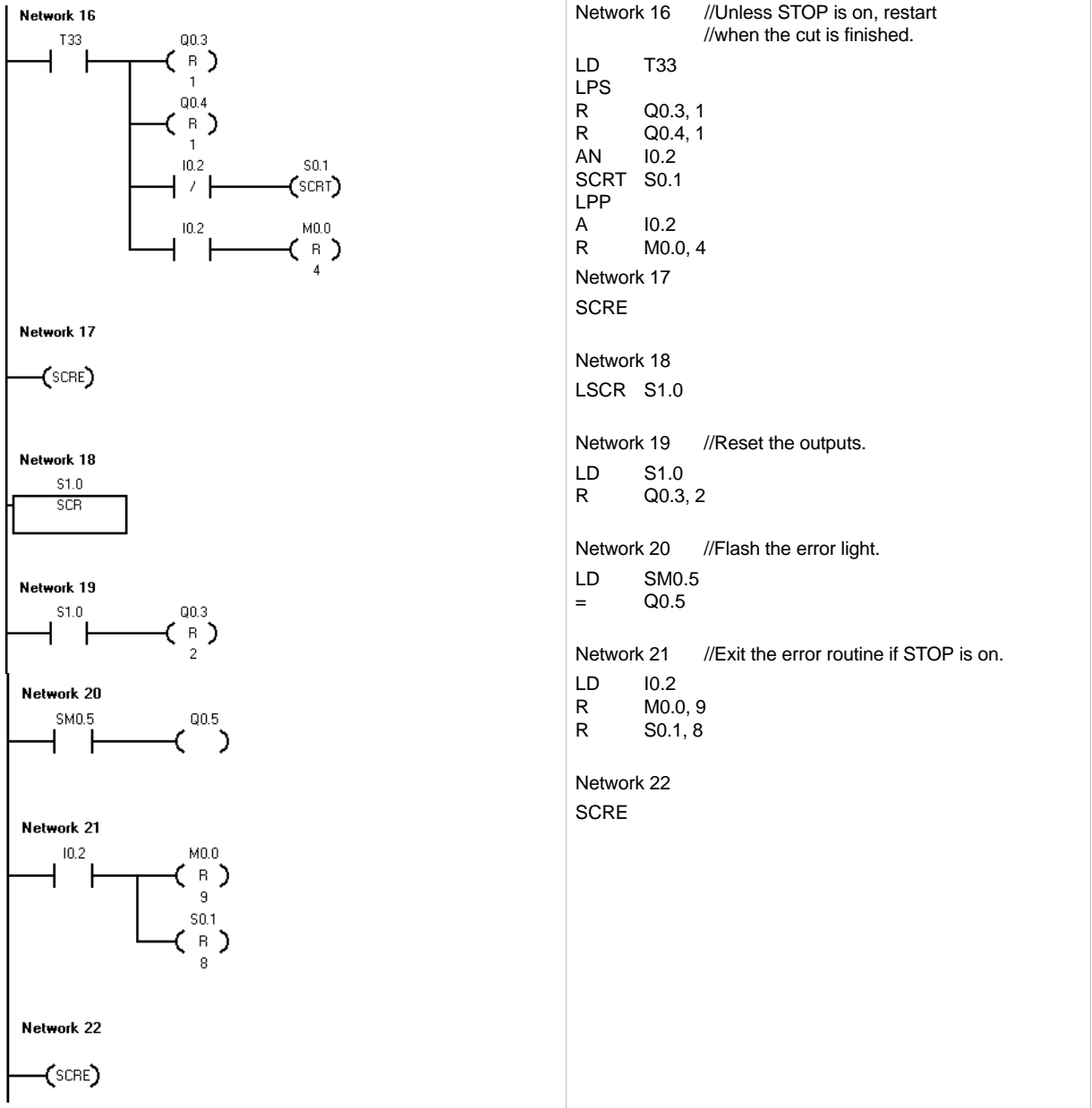

Monitoring the Position Module with the EM 253 Control Panel

To aid you in the development of your Position Control solution, STEP 7–Micro/WIN provides the EM 253 Control Panel. The Operation, Configuration and Diagnostics tabs make it easy for you to monitor and control the operation of the Position module during the startup and test phases of your development process.

Use the EM 253 Control Panel to verify that the Position module is wired correctly, to adjust the configuration data, and to test each movement profile.

Displaying and Controlling the Operation of the Position Module

The Operation tab of the control panel allows you to interact with the operations of the Position Module. The control panel displays the current speed, the current position and the current direction of the Position module. You can also see the status of the input and output LEDs (excluding the Pulse LEDs).

The control panel allows you to interact with the Position module by changing the speed and direction, by stopping and starting the motion, and by jogging the tool (if the motion is stopped).

You can also generate the following motion commands:

- Enable Manual Operation. This command allows you to use the manual controls for positioning the tool.
- Run a Motion Profile. This command allows you to select a profile to be executed. The control panel displays the status of the profile which is being executed by the Position module.
- Seek to a Reference Point. This command finds the reference point by using the configured search mode.

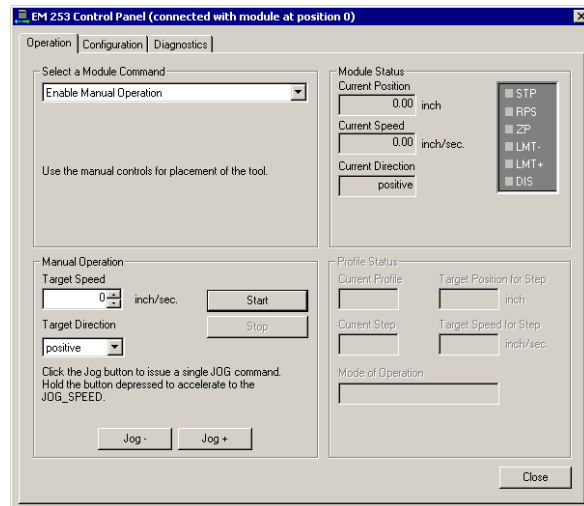

Figure 9-19 Operation Tab of the EM 253 Control Panel

- Load Reference Point Offset. After you use the manual controls to jog the tool to the new zero position, you then load the Reference Point Offset.
- Reload Current Position. This command updates the current position value and establishes a new zero position.
- Activate the DIS output and Deactivate the DIS output. These commands turn the DIS output of the Position module on and off.
- Pulse the CLR output. This command generates a 50 ms pulse on the CLR output of the Position module.
- Teach a Motion Profile. This command allows you to save the target position and speed for a motion profile and step as you manually position the tool. The control panel displays the status of the profile which is being executed by the Position module.
- Load Module Configuration. This command loads a new configuration by commanding the Position module to read the configuration block from the V memory of the S7-200.
- Move to an Absolute Position. This command allows you to move to a specified position at a target speed. Before using this command, you must have already established the zero position.
- Move by a Relative Amount. This command allows you to move a specified distance from the current position at a target speed. You can enter a positive or negative distance.
- Reset the Command Interface. This command clears the command byte for the Position module and sets the Done bit. Use this command if the Position module appears to not be responding to commands.

Displaying and Modifying the Configuration of the Position Module

The Configuration tab of the control panel allows you to view and modify the configuration settings for the Position module that are stored in the data block of the S7-200.

After you modify the configuration settings, you simply click a button to update the settings in both the STEP 7–Micro/Win project and the data block of the S7-200.

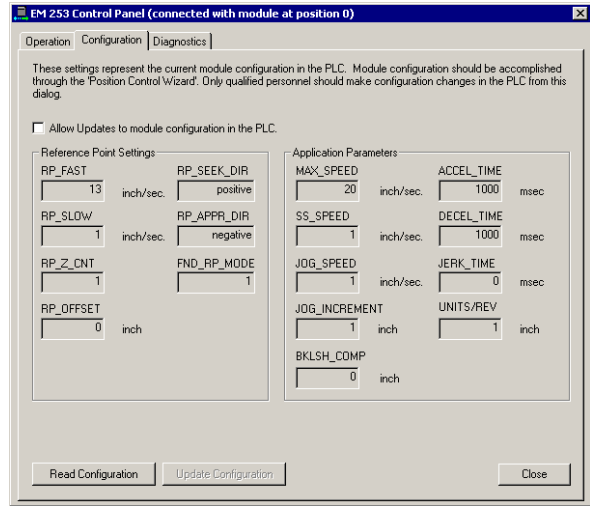

Figure 9-20 Configuration Tab of the EM 253 Control Panel

Displaying the Diagnostics Information for the Position Module

The Diagnostics tab of the control panel allows you to view the diagnostic information about the Position module.

You can view specific information about the Position module, such as the position of the module in the I/O chain, the module type and firmware version number, and the output byte used as the command byte for the module.

The control panel displays any error condition that resulted from a commanded operation. Refer to Table 9-13 on page 276 for the instruction error conditions.

You can also view any error condition reported by the Position module. Refer to Table 9-14 on page 277 for the module error conditions.

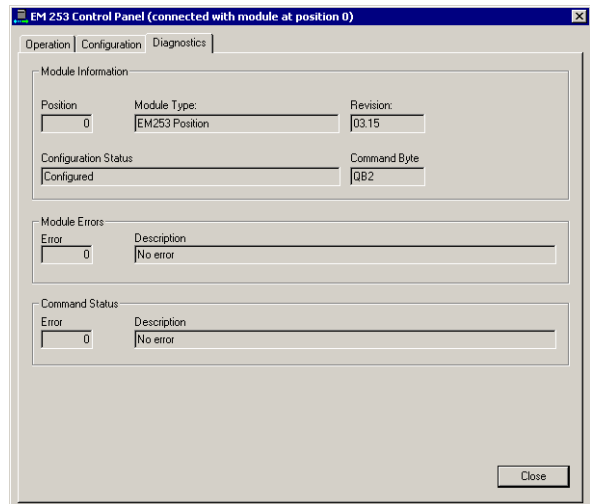

Figure 9-21 Diagnostics Tab of the EM 253 Control Panel

Error Codes for the Position Module and the Position Instructions

Table 9-13 Instruction Error Codes

Error Code	Description
0	No error
1	Aborted by user
2	Configuration error Use the EM 253 Control Panel Diagnostics tab to view error codes
3	Illegal command
4	Aborted due to no valid configuration Use the EM 253 Control Panel Diagnostics tab to view error codes
5	Aborted due to no user power
6	Aborted due to no defined reference point
7	Aborted due to STP input active
8	Aborted due to LMT- input active
9	Aborted due to LMT+ input active
10	Aborted due to problem executing motion
11	No profile block configured for specified profile
12	Illegal operation mode
13	Operation mode not supported for this command
14	Illegal number of steps in profile block
15	Illegal direction change
16	Illegal distance
17	RPS trigger occurred before target speed reached
18	Insufficient RPS active region width
19	Speed out of range
20	Insufficient distance to perform desired speed change
21	Illegal position
22	Zero position unknown
23 to 127	Reserved
128	Position module cannot process this instruction: either the Position module is busy with another instruction, or there was no Start pulse on this instruction
129	Position module error: <ul style="list-style-type: none"> ■ The location of the Position module or the Q memory address that was configured with the Position Control wizard does not match the actual location or memory address ■ Refer to SMB8 to SMB21 (I/O Module ID and Error Register) for other error conditions
130	Position module is not enabled
131	Position module is not available due to a module error or module not enabled (See the POSx_CTRL status)

Table 9-14 Module Error Codes

Error Code	Description
0	No error
1	No user power
2	Configuration block not present
3	Configuration block pointer error
4	Size of configuration block exceeds available V memory
5	Illegal configuration block format
6	Too many profiles specified
7	Illegal STP_RSP specification
8	Illegal LMT-_RPS specification
9	Illegal LMT+_RPS specification
10	Illegal FILTER_TIME specification
11	Illegal MEAS_SYS specification
12	Illegal RP_CFG specification
13	Illegal PLS/REV value
14	Illegal UNITS/REV value
15	Illegal RP_ZP_CNT value
16	Illegal JOG_INCREMENT value
17	Illegal MAX_SPEED value
18	Illegal SS_SPD value
19	Illegal RP_FAST value
20	Illegal RP_SLOW value
21	Illegal JOG_SPEED value
22	Illegal ACCEL_TIME value
23	Illegal DECEL_TIME value
24	Illegal JERK_TIME value
25	Illegal BKLSH_COMP value

Advanced Topics

Understanding the Configuration/Profile Table

The Position Control wizard has been developed to make motion applications easy by automatically generating the configuration and profile information based upon the answers you give about your position control system. Configuration/profile table information is provided for advanced users who want to create their own position control routines.

The configuration/profile table is located in the V memory area of the S7-200. As shown in Table 9-15, the configuration settings are stored in the following types of information:

- The configuration block contains information used to set up the module in preparation for executing motion commands.
- The interactive block supports direct setup of motion parameters by the user program.
- Each profile block describes a predefined move operation to be performed by the Position module. You can configure up to 25 profile blocks.



Tip

To create more than 25 motion profiles, you can exchange configuration/profile tables by changing the value stored in the configuration/profile table pointer.

Table 9-15 Configuration/Profile Table

Offset	Name	Function Description	Type																
Configuration Block																			
0	MOD_ID	Module identification field	—																
5	CB_LEN	The length of the configuration block in bytes (1 byte)	—																
6	IB_LEN	The length of the interactive block in bytes (1 byte)	—																
7	PF_LEN	The length of a single profile in bytes (1 byte)	—																
8	STP_LEN	The length of a single step in bytes (1 byte)	—																
9	STEPS	The number of steps allowed per profile (1 byte)	—																
10	PROFILES	Number of profiles from 0 to 25 (1 byte)	—																
11	Reserved	Set to 0x0000	—																
13	IN_OUT_CFG	<p>Specifies the use of the module inputs and outputs (1 byte)</p> <table border="1" style="margin-left: 40px;"> <tr> <td style="text-align: center;">MSB 7</td> <td style="text-align: center;">6</td> <td style="text-align: center;">5</td> <td style="text-align: center;">4</td> <td style="text-align: center;">3</td> <td style="text-align: center;">2</td> <td style="text-align: center;">1</td> <td style="text-align: center;">LSB 0</td> </tr> <tr> <td style="text-align: center;">P/D</td> <td style="text-align: center;">POL</td> <td style="text-align: center;">0</td> <td style="text-align: center;">0</td> <td style="text-align: center;">STP</td> <td style="text-align: center;">RPS</td> <td style="text-align: center;">LMT-</td> <td style="text-align: center;">LMT+</td> </tr> </table> <p>P/D This bit specifies the use of P0 and P1. Positive Polarity (POL=0): 0 – P0 pulses for positive rotation P1 pulses for negative rotation 1 – P0 pulses for rotation P1 controls rotation direction (0 – positive, 1 – negative) Negative Polarity (POL=1): 0 – P0 pulses for positive rotation P1 pulses for negative rotation 1 – P0 pulses for rotation P1 controls rotation direction (0 – positive, 1 – negative)</p> <p>POL This bit selects the polarity convention for P0 and P1. (0 – positive polarity, 1 – negative polarity)</p> <p>STP This bit controls the active level for the stop input.</p> <p>RPS This bit controls the active level for the RPS input.</p> <p>LMT- This bit controls the active level for the negative travel limit input.</p> <p>LMT+ This bit controls the active level for the positive travel limit input</p> <p>0 – Active high 1 – Active low</p>	MSB 7	6	5	4	3	2	1	LSB 0	P/D	POL	0	0	STP	RPS	LMT-	LMT+	—
MSB 7	6	5	4	3	2	1	LSB 0												
P/D	POL	0	0	STP	RPS	LMT-	LMT+												

Table 9-15 Configuration/Profile Table, continued

Offset	Name	Function Description	Type
14	STP_RSP	Specifies the response of the drive to the STP input (1 byte) 0 No action. Ignore the input condition. 1 Decelerate to a stop and indicate that the STP input is active. 2 Terminate the pulses and indicate STP input 3 to 255 Reserved (error if specified)	—
15	LMT-_RSP	Specifies the response of the drive to the negative limit input (1 byte) 0 No action. Ignore the input condition. 1 Decelerate to a stop and indicate that the limit has been reached. 2 Terminate the pulses and indicate that the limit has been reached. 3 to 255 Reserved (error if specified)	—
16	LMT+_RSP	Specifies the response of the drive to the positive limit input (1 byte) 0 No action. Ignore the input condition. 1 Decelerate to a stop and indicate that the limit has been reached. 2 Terminate pulses and indicate that the limit has been reached. 3 to 255 Reserved (error if specified)	—
17	FILTER_TIME	Specifies the filter time for the STP, LMT-, LMT+, and RPS inputs (1 byte)  '0000' 200 μsec '0101' 3200 μsec '0001' 400 μsec '0110' 6400 μsec '0010' 800 μsec '0111' 12800 μsec '0011' 1600 μsec '1000' No filter '0100' 1600 μsec '1001' to '1111' Reserved (error if specified)	—
18	MEAS_SYS	Specifies the measurement system (1 byte) 0 Pulses (speed is measured in pulses/second, and the position values are measured in pulses). Values are stored as DINT. 1 Engineering units (speed is measured in units/second, and the position values are measured in units). Values are stored as single-precision REAL. 2 to 255 Reserved (error if specified)	—
19	—	Reserved (Set to 0)	—
20	PLS/REV	Specifies the number of pulses per revolution of the motor (4 bytes) Only applicable when MEAS_SYS is set to 1.	DINT
24	UNITS/REV	Specifies the engineering units per revolution of the motor (4 bytes) Only applicable when MEAS_SYS is set to 1.	REAL
28	UNITS	Reserved for STEP 7–Micro/WIN to store a custom units string (4 bytes)	—
32	RP_CFG	Specifies the reference point search configuration (1 byte)  RP_SEEK_DIR This bit specifies the starting direction for a reference point search. (0 – positive direction, 1 – negative direction) RP_APPR_DIR This bit specifies the approach direction for terminating the reference point search. (0 – positive direction, 1 – negative direction) MODE Specifies the reference point search method. '0000' Reference point search disabled. '0001' The reference point is where the RPS input goes active. '0010' The reference point is centered within the active region of the RPS input. '0011' The reference point is outside the active region of the RPS input. '0100' The reference point is within the active region of the RPS input. '0101' to '1111' Reserved (error if selected)	—
33	—	Reserved (Set to 0)	—
34	RP_Z_CNT	Number of pulses of the ZP input used to define the reference point (4 bytes)	DINT

Table 9-15 Configuration/Profile Table, continued

Offset	Name	Function Description	Type
38	RP_FAST	Fast speed for the RP seek operation: MAX_SPD or less (4 bytes)	DINT REAL
42	RP_SLOW	Slow speed for the RP seek operation: maximum speed from which the motor can instantly go to a stop or less (4 bytes)	DINT REAL
46	SS_SPEED	Start/Stop Speed. (4 bytes) The starting speed is the maximum speed to which the motor can instantly go from a stop and the maximum speed from which the motor can instantly go to a stop. Operation below this speed is allowed, but the acceleration and deceleration times do not apply.	DINT REAL
50	MAX_SPEED	Maximum operating speed of the motor (4 bytes)	DINT REAL
54	JOG_SPEED	Jog speed. MAX_SPEED or less (4 bytes)	
58	JOG_INCREMENT	The jog increment value is the distance (or number of pulses) to move in response to a single jog pulse. (4 bytes)	DINT REAL
62	ACCEL_TIME	Time required to accelerate from minimum to maximum speed in milliseconds (4 bytes)	DINT
66	DECEL_TIME	Time required to decelerate from maximum to minimum speed in milliseconds (4 bytes)	DINT
70	BKLSH_COMP	Backlash compensation: the distance used to compensate for the system backlash on a direction change (4 bytes)	DINT REAL
74	JERK_TIME	Time during which jerk compensation is applied to the beginning and ending portions of an acceleration/deceleration curve (S curve). Specifying a value of 0 disables jerk compensation. The jerk time is given in milliseconds. (4 bytes)	DINT
Interactive Block			
78	MOVE_CMD	Selects the mode of operation (1 byte) 0 Absolute position 1 Relative position 2 Single-speed, continuous operation, positive rotation 3 Single-speed, continuous operation, negative rotation 4 Manual speed control, positive rotation 5 Manual speed control, negative rotation 6 Single-speed, continuous operation, positive rotation with triggered stop (RPS input signals stop) 7 Single-speed, continuous operation, negative rotation with triggered stop (RPS input signals stop) 8 to 255 – Reserved (error if specified)	—
79	—	Reserved. Set to 0	—
80	TARGET_POS	Target position to go to in this move (4 bytes)	DINT REAL
84	TARGET_SPEED	Target speed for this move (4 bytes)	DINT REAL
88	RP_OFFSET	Absolute position of the reference point (4 bytes)	DINT REAL
Profile Block 0			
92 (+0)	STEPS	Number of steps in this move sequence (1 byte)	—
93 (+1)	MODE	Selects the mode of operation for this profile block (1 byte) 0 Absolute position 1 Relative position 2 Single-speed, continuous operation, positive rotation 3 Single-speed, continuous operation, negative rotation 4 Reserved (error if specified) 5 Reserved (error if specified) 6 Single-speed, continuous operation, positive rotation with triggered stop (RPS selects speed) 7 Single-speed, continuous operation, negative rotation with triggered stop (RPS input signals stop) 8 Two-speed, continuous operation, positive rotation (RPS selects speed) 9 Two-speed, continuous operation, negative rotation (RPS selects speed) 10 to 255 – Reserved (error if specified)	—

Table 9-15 Configuration/Profile Table, continued

Offset	Name	Function Description	Type
94 (+2)	0	POS Position to go to in move step 0 (4 bytes)	DINT REAL
98 (+6)	0	SPEED Target speed for move step 0 (4 bytes)	DINT REAL
102 (+10)	1	POS Position to go to in move step 1 (4 bytes)	DINT REAL
106 (+14)	1	SPEED Target speed for move step 1 (4 bytes)	DINT REAL
110 (+18)	2	POS Position to go to in move step 2 (4 bytes)	DINT REAL
114 (+22)	2	SPEED Target speed for move step 2 (4 bytes)	DINT REAL
118 (+26)	3	POS Position to go to in move step 3 (4 bytes)	DINT REAL
122 (+30)	3	SPEED Target speed for move step 3 (4 bytes)	DINT REAL
Profile Block 1			
126 (+34)	STEPS	Number of steps in this move sequence (1 byte)	—
127 (+35)	MODE	Selects the mode of operation for this profile block (1 byte)	—
128 (+36)	0	POS Position to go to in move step 0 (4 bytes)	DINT REAL
132 (+40)	0	SPEED Target speed for move step 0 (4 bytes)	DINT REAL
...

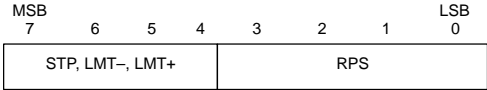
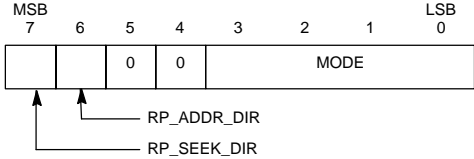
Special Memory Locations for the Position Module

The S7-200 allocates 50 bytes of special memory (SM) to each intelligent module, based on the physical position of the module in the I/O system. See Table 9-16. When the module detects an error condition or a change in status of the data, the module updates these SM locations. The first module updates SMB200 through SMB249 as required to report the error condition, the second module updates SMB250 through SMB299, and so on.

Table 9-16 Special Memory Bytes SMB200 to SMB549

SM Bytes for an intelligent module in:						
Slot 0	Slot 1	Slot 2	Slot 3	Slot 4	Slot 5	Slot 6
SMB200 to SMB249	SMB250 to SMB299	SMB300 to SMB349	SMB350 to SMB399	SMB400 to SMB449	SMB450 to SMB499	SMB500 to SMB549

Table 9-17 shows the structure of the SM data area allocated for an intelligent module. The definition is given as if this were the intelligent module is located in slot 0 of the I/O system.

Table 9-17 Special Memory Area Definition for the EM 253 Position Module

SM Address	Description																								
SMB200 to SMB215	Module name (16 ASCII characters). SMB200 is the first character: "EM253 Position"																								
SMB216 to SMB219	Software revision number (4 ASCII characters). SMB216 is the first character.																								
SMW220	Error code for the module. See Table 9-14 for a description of the error codes.																								
SMB222	<p>Input/output status. Reflects the status of the inputs and outputs of the module.</p> <table border="1" style="margin-left: 40px;"> <tr> <td colspan="4" style="text-align: center;">MSB</td> <td colspan="4" style="text-align: center;">LSB</td> </tr> <tr> <td style="text-align: center;">7</td> <td style="text-align: center;">6</td> <td style="text-align: center;">5</td> <td style="text-align: center;">4</td> <td style="text-align: center;">3</td> <td style="text-align: center;">2</td> <td style="text-align: center;">1</td> <td style="text-align: center;">0</td> </tr> <tr> <td style="text-align: center;">DIS</td> <td style="text-align: center;">0</td> <td style="text-align: center;">0</td> <td style="text-align: center;">STP</td> <td style="text-align: center;">LMT-</td> <td style="text-align: center;">LMT+</td> <td style="text-align: center;">RPS</td> <td style="text-align: center;">ZP</td> </tr> </table> <p>DIS Disable outputs 0 = No current flow 1 = Current flow STP Stop input 0 = No current flow 1 = Current flow LMT- Negative travel limit input 0 = No current flow 1 = Current flow LMT+ Positive travel limit input 0 = No current flow 1 = Current flow RPS Reference point switch input 0 = No current flow 1 = Current flow ZP Zero pulse input 0 = No current flow 1 = Current flow</p>	MSB				LSB				7	6	5	4	3	2	1	0	DIS	0	0	STP	LMT-	LMT+	RPS	ZP
MSB				LSB																					
7	6	5	4	3	2	1	0																		
DIS	0	0	STP	LMT-	LMT+	RPS	ZP																		
SMB223	<p>Instantaneous module status. Reflects the status of the module configuration and rotation direction status.</p> <table border="1" style="margin-left: 40px;"> <tr> <td colspan="6" style="text-align: center;">MSB</td> <td colspan="2" style="text-align: center;">LSB</td> </tr> <tr> <td style="text-align: center;">7</td> <td style="text-align: center;">6</td> <td style="text-align: center;">5</td> <td style="text-align: center;">4</td> <td style="text-align: center;">3</td> <td style="text-align: center;">2</td> <td style="text-align: center;">1</td> <td style="text-align: center;">0</td> </tr> <tr> <td style="text-align: center;">0</td> <td style="text-align: center;">0</td> <td style="text-align: center;">0</td> <td style="text-align: center;">0</td> <td style="text-align: center;">0</td> <td style="text-align: center;">OR</td> <td style="text-align: center;">R</td> <td style="text-align: center;">CFG</td> </tr> </table> <p>OR Target speed out of range 0 = In range 1 = Out of range R Direction of rotation 0 = Positive rotation 1 = Negative rotation CFG Module configured 0 = Not configured 1 = Configured</p>	MSB						LSB		7	6	5	4	3	2	1	0	0	0	0	0	0	OR	R	CFG
MSB						LSB																			
7	6	5	4	3	2	1	0																		
0	0	0	0	0	OR	R	CFG																		
SMB224	CUR_PF is a byte that indicates the profile currently being executed.																								
SMB225	CUR_STP is a byte that indicates the step currently being executed in the profile.																								
SMD226	CUR_POS is a double-word value that indicates the current position of the module.																								
SMD230	CUR_SPD is a double-word value that indicates the current speed of the module.																								
SMB234	<p>Result of the instruction. See Table 9-13 for descriptions of the error codes. Error conditions above 127 are generated by the instruction subroutines created by the wizard.</p> <table border="1" style="margin-left: 40px;"> <tr> <td colspan="2" style="text-align: center;">MSB</td> <td colspan="6" style="text-align: center;">LSB</td> </tr> <tr> <td style="text-align: center;">7</td> <td style="text-align: center;">6</td> <td colspan="6"></td> </tr> <tr> <td style="text-align: center;">D</td> <td colspan="6" style="text-align: center;">ERROR</td> </tr> </table> <p>D Done bit 0= Operation in progress 1= Operation complete (set by the module during initialization)</p>	MSB		LSB						7	6							D	ERROR						
MSB		LSB																							
7	6																								
D	ERROR																								
SMB235 to SMB244	Reserved																								
SMB245	Offset to the first Q byte used as the command interface to this module. The offset is supplied by the S7-200 automatically for the convenience of the user and is not needed by the module.																								
SMD246	Pointer to the V memory location of the configuration/profile table. A pointer value to an area other than V memory is not valid. The Position module monitors this location until it receives a non-zero pointer value.																								

Understanding the Command Byte for the Position Module

The Position module provides one byte of discrete outputs which is used as the command byte. Figure 9-22 shows the command byte definition. Table 9-18 shows the Command_code definitions.

A write to the command byte where the R bit changes from 0 to 1 is interpreted by the module as a new command.

If the module detects a transition to idle (R bit changes state to 0) while a command is active, then the operation in progress is aborted and, if a motion is in progress, then a decelerated stop is performed.

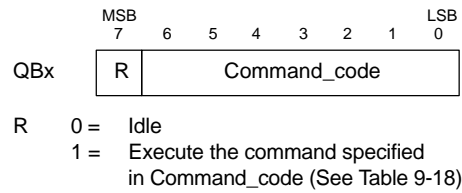

Figure 9-22 Definition of the Command Byte

After an operation has completed, the module must see a transition to idle before a new command is accepted. If an operation is aborted, then the module must complete any deceleration before a new command is accepted. Any change in the Command_code value while a command is active is ignored.

The response of the Position module to a change in the operating mode of the S7-200 or to a fault condition is governed by the effect that the S7-200 exerts over the discrete outputs according to the existing definition of the S7-200 function:

- If the S7-200 changes from STOP to RUN:* The program in the S7-200 controls the operation of the Position module.
- If the S7-200 changes from RUN to STOP:* You can select the state that the discrete outputs are to go to on a transition to STOP or that the outputs are to retain their last state.
 - *If the R bit is turned off when going to STOP:* The Position module decelerates any motion in progress to a stop
 - *If the R bit is turned on when going to STOP:* The Position module completes any command that is in progress. If no command is in progress, the Position module executes the command which is specified by the Command_code bits.
 - *If the R bit is held in its last state:* The Position module completes any motion in progress.
- If the S7-200 detects a fatal error and turns off all discrete outputs:* The Position module decelerates any motion in progress to a stop.

The Position module implements a watchdog timer that turns the outputs off if communications with the S7-200 are lost. If the output watchdog timer expires, the Position module decelerates any motion in progress to a stop.

If a fatal error in the hardware or firmware of the module is detected, the Position module sets the P0, P1, DIS and CLR outputs to the inactive state.

Table 9-18 Command_code Definitions

Command_code	Command
000 0000 to 000 1111	0 to 24 Execute motion specified in Profile Blocks 0 to 24
100 0000 to 111 0101	25 to 117 Reserved (Error if specified)
111 0110	118 Activate the DIS output
111 0111	119 Deactivate the DIS output
111 1000	120 Pulse the CLR output
111 1001	121 Reload current position
111 1010	122 Execute motion specified in the Interactive Block
111 1011	123 Capture reference point offset
111 1100	124 Jog positive rotation
111 1101	125 Jog negative rotation
111 1110	126 Seek to reference point position
111 1111	127 Reload configuration

Table 9-19 Motion Commands

Command	Description
Commands 0 to 24: <i>Executes the motion specified in profile blocks 0 to 24</i>	<p>When this command is executed, the Position module performs the motion operation specified in the MODE field of the profile block indicated by the Command_code portion of the command.</p> <ul style="list-style-type: none"> ■ In Mode 0 (absolute position), the motion profile block defines from one to four steps with each step containing both the position (POS) and speed (SPEED) that describes the move segment. The POS specification represents an absolute location, which is based on the location designated as reference point. The direction of movement is determined by the relationship between the current position and the position of the first step in the profile. In a multi-step move a reversal of direction of travel is prohibited and results in an error condition being reported. ■ In Mode 1 (relative position), the motion profile block defines from one to four steps with each step containing both the position (POS) and the speed (SPEED) that describes the move segment. The sign of the position value (POS) determines the direction of the movement. In a multi-step move, a reversal of direction of travel is prohibited and results in the reporting of an error condition. ■ In Modes 2 and 3 (single-speed, continuous operation modes), the position (POS) specification is ignored and the module accelerates to the speed specified in the SPEED field of the first step. Mode 2 is used for positive rotation, and Mode 3 is used for negative rotation. Movement stops when the command byte transitions to Idle. ■ In Modes 6 and 7 (single-speed, continuous operation modes with triggered stop), the module accelerates to the speed specified in the SPEED field of the first step. If and when the RPS input becomes active, movement stops after completing the distance specified in the POS field of the first step. (The distance specified in the POS field must include the deceleration distance.) If the POS field is zero when the RPS input becomes active, the Position module decelerates to a stop. Mode 6 is used for positive rotation, and Mode 7 is used for negative rotation. ■ In Modes 8 and 9, the binary value of the RPS input selects one of two speed values as specified by the first two steps in the profile block. <ul style="list-style-type: none"> – If the RPS is inactive: Step 0 controls the speed of the drive. – If the RPS is active: Step 1 controls the speed of the drive. Mode 8 is used for positive rotation, and Mode 9 is used for negative rotation. The SPEED value controls the speed of movement. The POS values are ignored in this mode.
Command 118 <i>Activates the DIS output</i>	<p>When this command is executed, the Position module activates the DIS output.</p>
Command 119 <i>Deactivates the DIS output</i>	<p>When this command is executed, the Position module deactivates the DIS output.</p>
Command 120 <i>Pulses the CLR output</i>	<p>When this command is executed, the Position module generates a 50-millisecond pulse on the CLR output.</p>
Command 121 <i>Reloads the Current Position</i>	<p>When this command is executed, the Position module sets the current position to the value found in the TARGET_POS field of the interactive block.</p>
Command 122 <i>Execute the motion specified in the interactive block</i>	<p>When this command is executed, the Position module performs the motion operation specified in the MOVE_CMD field of the interactive block.</p> <ul style="list-style-type: none"> ■ In Modes 0 and 1 (absolute and relative motion modes), a single step motion is performed based upon the target speed and position information provided in the TARGET_SPEED and TARGET_POS fields of the interactive block. ■ In Modes 2 and 3 (single-speed, continuous operation modes), the position specification is ignored, and the Position module accelerates to the speed specified in the TARGET_SPEED field of the interactive block. Movement stops when the command byte transitions to Idle. ■ In Modes 4 and 5 (manual speed control modes), the position specification is ignored and your program loads the value of speed changes into the TARGET_SPEED field of the interactive block. The Position module continuously monitors this location and responds appropriately when the speed value changes.

Table 9-19 Motion Commands, continued

Command	Description
Command 123 <i>Capture the Reference Point offset</i>	<p>When this command is executed, the Position module establishes a zero position that is at a different location from the reference point position.</p> <p>Before issuing this command, you must have determined the position of the reference point and must also have jogged the machine to the work starting position. After receiving this command, the Position module computes the offset between the work starting position (the current position) and the reference point position and writes the computed offset to the RP_OFFSET field of the Interactive Block. The current position is then set to 0 to establish the work starting position as the zero position.</p> <p>In the event that the stepper motor loses track of its position (for example, if power is lost or the stepper motor is repositioned manually) the Seek to Reference Point Position command can be issued to re-establish the zero position automatically.</p>
Command 124 <i>Jog positive rotation</i>	<p>This command allows you to manually issue pulses for moving the stepper motor in the positive direction.</p> <p>If the command remains active for less than 0.5 seconds, the Position module issues pulses to travel the distance specified in JOG_INCREMENT.</p> <p>If the command remains active for 0.5 seconds or longer, the motion module begins to accelerate to the specified JOG_SPEED.</p> <p>When a transition to idle is detected, the Position module decelerates to a stop.</p>
Command 125 <i>Jog negative rotation</i>	<p>This command allows you to manually issue pulses for moving the stepper motor in the negative direction.</p> <p>If the command remains active for less than 0.5 seconds, the Position module issues pulses to travel the distance specified in JOG_INCREMENT.</p> <p>If the command remains active for 0.5 seconds or longer, the Position module begins to accelerate to the specified JOG_SPEED.</p> <p>When a transition to idle is detected, the Position module decelerates to a stop.</p>
Command 126 <i>Seek to Reference Point position</i>	<p>When this command is executed, the Position module initiates a reference point seek operation using the specified search method. When the reference point has been located and motion has stopped, the Position module loads the value read from the RP_OFFSET field of the interactive block into the current position and pulses the CLR output on for 50 milliseconds.</p>
Command 127 <i>Reload the configuration</i>	<p>When this command is executed, the Position module reads the configuration/profile table pointer from the appropriate location in SM memory and then reads the configuration block from the location specified by the configuration/profile table pointer. The Position module compares the configuration data just obtained against the existing module configuration and performs any required setup changes or recalculations. Any cached profiles are discarded.</p>

Understanding the Profile Cache of the Position Module

The Position module stores the execution data for up to 4 profiles in cache memory. When the Position module receives a command to execute a profile, it checks to see if the requested profile is stored in the cache memory. If the execution data for the profile is resident in the cache, the Position module immediately executes the profile. If the the execution data for the profile is not resident in the cache, the Position module reads the profile block information from the configuration/profile table in the S7-200 and calculates the execution data for the profile before executing the profile.

Command 122 (Execute the motion specified in the interactive block) does not use cache memory to store the execution data, but always reads the interactive block from the configuration/profile table in the S7-200 and calculates the execution data for the motion.

Reconfiguring the Position module deletes all of the execution data stored in the cache memory.

Creating Your Own Position Control Instructions

The Position Control wizard creates the position instructions for controlling the operation of the Position module; however, you can also create your own instructions. The following STL code segment provides an example of how you might create your own control instructions for the Position module.

This example uses an S7-200 CPU 224 with a Position module located in slot 0. The Position module is configured on power-up. CMD_STAT is a symbol for SMB234, CMD is a symbol for QB2, and NEW_CMD is a symbol for the profile.

Sample Program: Controlling the Position Module

```

Network 1    //New move command state
LSCR      State_0

Network 2    //CMD_STAT is a symbol for SMB234
           //CMD is a symbol for QB2
           //NEW_CMD is a symbol for the profile.
           //
           //1. Clear the Done bit of the Position module.
           //2. Clear the command byte of the Position module.
           //3. Issue the new command.
           //4. Wait for the command to be executed.

LD        SM0.0
MOVB     0, CMD_STAT
BIW      0, CMD
BIW      NEW_CMD, CMD
SCRT     State_1

Network 3
SCRE

Network 4    //Wait for the command to be completed.
LSCR      State_1

Network 5    //If the command is complete without error, go to the idle state.
LDB=     CMD_STAT, 16#80
SCRT     Idle_State

Network 6    //If the command is complete with an error, go to the error handling state.
LDB>     CMD_STAT, 16#80
SCRT     Error_State

Network 7
SCRE

```

Creating a Program for the Modem Module

10

The EM 241 Modem module allows you to connect your S7-200 directly to an analog telephone line, and supports communications between your S7-200 and STEP 7–Micro/WIN. The Modem module also supports the Modbus slave RTU protocol. Communications between the Modem module and the S7-200 are made over the Expansion I/O bus.

STEP 7–Micro/WIN provides a Modem Expansion wizard to help set up a remote modem or a Modem module for connecting a local S7-200 to a remote device.

In This Chapter

Features of the Modem Module	288
Using the Modem Expansion Wizard to Configure the Modem Module	294
Overview of Modem Instructions and Restrictions	298
Instructions for the Modem Module	299
Sample Program for the Modem Module	303
S7-200 CPUs that Support Intelligent Modules	303
Special Memory Location for the Modem Module	304
Advanced Topics	306
Messaging Telephone Number Format	308
Text Message Format	309
CPU Data Transfer Message Format	310

Features of the Modem Module

The Modem module allows you to connect your S7-200 directly to an analog telephone line and provides the following features:

- Provides international telephone line interface
- Provides a modem interface to STEP 7–Micro/WIN for programming and troubleshooting (teleservice)
- Supports the Modbus RTU protocol
- Supports numeric and text paging
- Supports SMS messaging
- Allows CPU-to-CPU or CPU-to Modbus data transfers
- Provides password protection
- Provides security callback
- The Modem module configuration is stored in the CPU

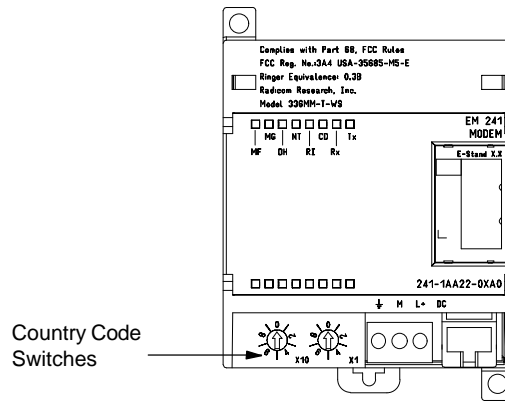

Figure 10-1 EM 241 Modem Module

You can use the STEP 7–Micro/WIN Modem Expansion wizard to configure the Modem module. Refer to Appendix A for the specifications of the Modem module.

International Telephone Line Interface

The Modem module is a standard V.34 (33.6 kBaud), 10-bit modem, and is compatible with most internal and external PC modems. The Modem module does not communicate with 11-bit modems.

You connect the Modem module to the telephone line with the six-position four-wire RJ11 connector mounted on the front of the module. See Figure 10-2.

An adapter may be required to convert the RJ11 connector for connection to the standard telephone line termination in the various countries. Refer to the documentation for your adapter connector for more information.

The modem and telephone line interface is powered from an external 24 VDC supply. This can be connected to the CPU sensor supply or to an external source. Connect the ground terminal on the Modem module to the system earth ground.

The Modem module automatically configures the telephone interface for country-specific operation when power is applied to the module. The two rotary switches on the front of the module select the country code. You must set the switches to the desired country selection before the Modem module is powered up. Refer to Table 10-1 for switch settings for the countries supported.

Pin	Description
3	Ring
4	Tip

Reverse connection is allowed.

Figure 10-2 View of RJ11 Jack

Table 10-1 Countries Supported by the EM 241

Switch Setting	Country
01	Austria
02	Belgium
05	Canada
08	Denmark
09	Finland
10	France
11	Germany
12	Greece
16	Ireland
18	Italy
22	Luxembourg
25	Netherlands
27	Norway
30	Portugal
34	Spain
35	Sweden
36	Switzerland
38	U.K.
39	U.S.A.

STEP 7–Micro/WIN Interface

The Modem module allows you to communicate with STEP 7–Micro/WIN over a telephone line (teleservice). You do not need to configure or program the S7-200 CPU to use the Modem module as the remote modem when used with STEP 7–Micro/WIN.

Follow these steps to use the Modem module with STEP 7–Micro/WIN:

1. Remove the power from the S7-200 CPU and attach the Modem module to the I/O expansion bus. Do not attach any I/O modules while the S7-200 CPU is powered up.
2. Connect the telephone line to the Modem module. Use an adapter if necessary.
3. Connect 24 volts DC to the Modem module terminal blocks.
4. Connect the Modem module terminal block ground connection to the system ground.
5. Set the country code switches.
6. Power up the S7-200 CPU and the Modem module.
7. Configure STEP 7–Micro/WIN to communicate to a 10-bit modem.

Modbus RTU Protocol

You can configure the Modem module to respond as a Modbus RTU slave. The Modem module receives Modbus requests over the modem interface, interprets those requests and transfers data to or from the CPU. The Modem module then generates a Modbus response and transmits it out over the modem interface.



Tip

If the Modem module is configured to respond as a Modbus RTU slave, STEP 7–Micro/WIN is not able to communicate to the Modem module over the telephone line.

The Modem module supports the Modbus functions shown in Table 10-2.

Modbus functions 4 and 16 allow reading or writing a maximum of 125 holding registers (250 bytes of V memory) in one request. Functions 5 and 15 write to the output image register of the CPU. These values can be overwritten by user program.

Modbus addresses are normally written as 5 or 6 character values containing the data type and the offset. The first one or two characters determine the data type, and the last four characters select the proper value within the data type. The Modbus master device maps the addresses to the correct Modbus functions.

Table 10-2 Modbus Functions Supported by Modem Module

Function	Description
Function 01	Read coil (output) status
Function 02	Read input status
Function 03	Read holding registers
Function 04	Read input (analog input) registers
Function 05	Write single coil (output)
Function 06	Preset single register
Function 15	Write multiple coils (outputs)
Function 16	Preset multiple registers

Table 10-3 shows the Modbus addresses supported by the Modem module, and the mapping of Modbus addresses to the S7-200 CPU addresses.

Use the Modem Expansion wizard to create a configuration block in for the Modem module to support Modbus RTU protocol. The Modem module configuration block must be downloaded to the CPU data block before you can use the Modbus protocol.

Table 10-3 Mapping Modbus Addresses to the S7-200 CPU

Modbus Address	S7-200 CPU Address
000001	Q0.0
000002	Q0.1
000003	Q0.2
...	...
000127	Q15.6
000128	Q15.7
010001	I0.0
010002	I0.1
010003	I0.2
...	...
010127	I15.6
010128	I15.7
030001	AIW0
030002	AIW2
030003	AIW4
...	...
030032	AIW62
040001	VW0
040002	VW2
040003	VW4
...	...
04xxxx	VW 2*(xxxx-1)

Paging and SMS Messaging

The Modem module supports sending numeric and text paging messages, and SMS (Short Message Service) messages to cellular phones (where supported by the cellular provider). The messages and telephone numbers are stored in the Modem module configuration block which must be downloaded to the data block in the S7-200 CPU. You can use the Modem Expansion wizard to create the messages and telephone numbers for the Modem module configuration block. The Modem Expansion wizard also creates the program code to allow your program to initiate the sending of the messages.

10

Numeric Paging

Numeric paging uses the tones of a touch tone telephone to send numeric values to a pager. The Modem module dials the requested paging service, waits for the voice message to complete, and then sends the tones corresponding to the digits in the paging message. The digits 0 through 9, asterisk (*), A, B, C and D are allowed in the paging message. The actual characters displayed by a pager for the asterisk and A, B, C, and D characters are not standardized, and are determined by the pager and the paging service provider.

Text Paging

Text paging allows alphanumeric messages to be transmitted to a paging service provider, and from there to a pager. Text paging providers normally have a modem line that accepts text pages. The Modem module uses Telelocator Alphanumeric Protocol (TAP) to transmit the text messages to the service provider. Many providers of text paging use this protocol to accept messages.

Short Message Service (SMS)

Short Message Service (SMS) messaging is supported by some cellular telephone services, generally those that are GSM compatible. SMS allows the Modem module to send a message over an analog telephone line to an SMS provider. The SMS provider then transmits the message to the cellular telephone, and the message appears on the text display of the telephone. The Modem module uses the Telelocator Alphanumeric Protocol (TAP) and the Universal Computer Protocol (UCP) to send messages to the SMS provider. You can send SMS messages only to SMS providers that support these protocols on a modem line.

Embedded Variables in Text and SMS Messages

The Modem module can embed data values from the CPU in the text messages and format the data values based on a specification in the message. You can specify the number of digits to the left and right of the decimal point, and whether the decimal point is a period or a comma. When the user program commands the Modem module to transmit a text message, the Modem module retrieves the message from the CPU, determines what CPU values are needed within the message, retrieves those values from the CPU, and then formats and places the values within the text message before transmitting the message to the service provider.

The telephone number of the messaging provider, the message, and the variables embedded within the message are read from the CPU over multiple CPU scan cycles. Your program should not modify telephone numbers or messages while a message is being sent. The variables embedded within a message can continue to be updated during the sending of a message. If a message contains multiple variables, those variables are read over multiple scan cycles of the CPU. If you want all of the embedded variables within a message to be consistent, you must not change any of the embedded variables after you send a message.

Data Transfers

The Modem module allows your program to transfer data to another CPU or to a Modbus device over the telephone line. The data transfers and telephone numbers are configured with the Modem Expansion wizard, and are stored in the Modem module configuration block. The configuration block is then downloaded to the data block in the S7-200 CPU. The Modem Expansion wizard also creates program code to allow your program to initiate the data transfers.

A data transfer can be either a request to read data from a remote device, or a request to write data to a remote device. A data transfer can read or write between 1 and 100 words of data. Data transfers move data to or from the V memory of the attached CPU.

The Modem Expansion wizard allows you to create a data transfer consisting of a single read from the remote device, a single write to the remote device, or both a read from and a write to the remote device.

Data transfers use the configured protocol of the Modem module. If the Modem module is configured to support PPI protocol (where it responds to STEP 7–Micro/WIN), the Modem module uses the PPI protocol to transfer data. If the Modem module is configured to support the Modbus RTU protocol, data transfers are transmitted using the Modbus protocol.

The telephone number of the remote device, the data transfer request and the data being transferred are read from the CPU over multiple CPU scan cycles. Your program should not modify telephone numbers or messages while a message is being sent. Also, you should not modify the data being transferred while a message is being sent.

If the remote device is another Modem module, the password function can be used by the data transfers by entering the password of the remote Modem module in the telephone number configuration. The callback function cannot be used with data transfers.

Password Protection

The password security of the Modem module is optional and is enabled with the Modem Expansion wizard. The password used by the Modem module is not the same as the CPU password. The Modem module password is a separate 8-character password that the caller must supply to the Modem module before being allowed access to the attached CPU. The password is stored in the V memory of the CPU as part of the Modem module configuration block. The Modem module configuration block must be downloaded to the data block of the attached CPU.

If the CPU has the password security enabled in the System Data Block, the caller must supply the CPU password to gain access to any password protected functions.

Security Callback

The callback function of the Modem module is optional and is configured with the Modem Expansion wizard. The callback function provides additional security for the attached CPU by allowing access to the CPU only from predefined telephone numbers. When the callback function is enabled, the Modem module answers any incoming calls, verifies the caller, and then disconnects the line. If the caller is authorized, the Modem module then dials a predefined telephone number for the caller, and allows access to the CPU.

The Modem module supports three callback modes:

- Callback to a single predefined telephone number
- Callback to multiple predefined telephone numbers
- Callback to any telephone number

The callback mode is selected by checking the appropriate option in the Modem Expansion wizard and then defining the callback telephone numbers. The callback telephone numbers are stored in the Modem module configuration block stored in the data block of the attached CPU.

The simplest form of callback is to a single predefined telephone number. If only one callback number is stored in the Modem module configuration block, whenever the Modem module answers an incoming call, it notifies the caller that callback is enabled, disconnects the caller, and then dials the callback number specified in the configuration block.

The Modem module also supports callback for multiple predefined telephone numbers. In this mode the caller is asked for a telephone number. If the supplied number matches one of the predefined telephone numbers in the Modem module configuration block, the Modem module disconnects the caller, and then calls back using the matching telephone number from the configuration block. The user can configure up to 250 callback numbers.

Where there are multiple predefined callback numbers, the callback number supplied when connecting to the Modem module must be an exact match of the number in the configuration block of the Modem module except for the first two digits. For example, if the configured callback is 91(123)4569999 because of a need to dial an outside line (9) and long distance (1), the number supplied for the callback could be any of the following:

- 91(123)4569999
- 1(123)4569999
- (123)4569999

All of the above telephone number are considered to be a callback match. The Modem module uses the callback telephone number from its configuration block when performing the callback, in this example 91(123)4569999. When configuring multiple callback numbers, make sure that all telephone numbers are unique excluding the first two digits. Only the numeric characters in a telephone number are used when comparing callback numbers. Characters such as commas or parenthesis are ignored when comparing callback numbers.

The callback to any telephone number is set up in the Modem Expansion wizard by selecting the "Enable callbacks to any phone number" option during the callback configuration. If this option is selected, the Modem module answers an incoming call and requests a callback telephone number. After the telephone number is supplied by the caller, the Modem module disconnects and dials that telephone number. This callback mode only provides a means to allow telephone charges to be billed to the Modem module's telephone connection and does not provide any security for the S7-200 CPU. The Modem module password should be used for security if this callback mode is used.

The Modem module password and callback functions can be enabled at the same time. The Modem module requires a caller to supply the correct password before handling the callback.

Configuration Table for the Modem Module

All of the text messages, telephone numbers, data transfer information, callback numbers and other options are stored in a Modem module configuration table which must be loaded into the V memory of the S7-200 CPU. The Modem Expansion wizard guides you through the creation of a Modem module configuration table. STEP 7–Micro/WIN then places the Modem module configuration table in the Data Block which is downloaded to the S7-200 CPU.

The Modem module reads this configuration table from the CPU on startup and within five seconds of any STOP-to-RUN transition of the CPU. The Modem module does not read a new configuration table from the CPU as long as the Modem module is online with STEP 7–Micro/WIN. If a new configuration table is downloaded while the Modem module is online, the Modem module reads the new configuration table when the online session is ended.

If the Modem module detects an error in the configuration table, the Module Good (MG) LED on the front of the module flashes on and off. Check the PLC Information screen in STEP 7–Micro/WIN, or read the value in SMW220 (for module slot 0) for information about the configuration error. The Modem module configuration errors are listed in Table 10-4. If you use the Modem Expansion wizard to create the Modem module configuration table, STEP 7–Micro/WIN checks the data before creating the configuration table.

Table 10-4 EM 241 Configuration Errors (Hexadecimal)

Error	Description
0000	No error
0001	No 24 VDC external power
0002	Modem failure
0003	No configuration block ID – The EM 241 identification at the start of the configuration table is not valid for this module.
0004	Configuration block out of range – The configuration table pointer does not point to V memory, or some part of the table is outside the range of V memory for the attached CPU.
0005	Configuration error – Callback is enabled and the number of callback telephone numbers equals 0 or it is greater than 250. The number of messages is greater than 250. The number of messaging telephone numbers is greater than 250, or if length of the messaging telephone numbers is greater than 120 bytes.
0006	Country selection error – The country selection on the two rotary switches is not a supported value.
0007	Phone number too large – Callback is enabled and the callback number length is greater than the maximum.
0008 to 00FF	Reserved
01xx	Error in callback number xx – There are illegal characters in callback telephone number xx. The value xx is 1 for the first callback number, 2 for the second, etc.
02xx	Error in telephone number xx – One of the fields in a message telephone number xx or a data transfer telephone number xx contains an illegal value. The value xx is 1 for the first telephone number, 2 for the second, etc.
03xx	Error in message xx – Message or data transfer number xx exceeds the maximum length. The value xx is 1 for the first message, 2 for the second, etc.
0400 to FFFF	Reserved

Status LEDs of the Modem Module

The Modem module has 8 status LEDs on the front panel. Table 10-5 describes the status LEDs.

Table 10-5 EM 241 Status LEDs

LED	Description
MF	Module Fail – This LED is on when the module detects a fault condition such as: <ul style="list-style-type: none"> ■ No 24 VDC external power ■ Timeout of the I/O watchdog ■ Modem failure ■ Communications error with the local CPU
MG	Module Good – This LED is on when there is no module fault condition. The Module Good LED flashes if there is a error in the configuration table, or the user has selected an illegal country setting for the telephone line interface. Check the PLC Information screen in STEP 7–Micro/WIN or read the value in SMW220 (for module slot 0) for information about the configuration error.
OH	Off Hook – This LED is on when the EM 241 is actively using the telephone line.
NT	No Dial Tone – This LED indicates an error condition and turns on when the EM 241 has been commanded to send a message and there is no dial tone on the telephone line. This is only an error condition if the EM 241 has been configured to check for a dial tone before dialing. The LED remains on for approximately 5 seconds after a failed dial attempt.
RI	Ring Indicator –This LED indicates that the EM 241 is receiving an incoming call.
CD	Carrier Detect – This LED indicates that a connection has been established with a remote modem.
Rx	Receive Data – This LED flashes on when the modem is receiving data.
Tx	Transmit Data – This LED flashes on when the modem is transmitting data.

Using the Modem Expansion Wizard to Configure the Modem Module

Start the Modem Expansion wizard from the STEP 7–Micro/WIN Tools menu or from the Tools portion of the Navigation Bar.

To use this wizard, the project must be compiled and set to Symbolic Addressing Mode. If you have not already compiled your program, compile it now.

1. On first screen of the Modem Expansion wizard, select Configure an EM 241 Modem module and click Next>.
2. The Modem Expansion wizard requires the Modem module's position relative to the S7-200 CPU in order to generate the correct program code. Click the Read Modules button to automatically read the positions of the intelligent modules attached to the CPU. Expansion modules are numbered sequentially starting at zero. Double-click the Modem module that you want to configure, or set the Module Position field to the position of the Modem module. Click Next>.

For an S7-200 CPU with firmware prior to version 1.2, you must install the intelligent module next to the CPU in order for the Modem Expansion wizard to configure the module.

3. The password protection screen allows you to enable password protection for the Modem module and assign a 1 to 8 character password for the module. This password is independent of the S7-200 CPU password. When the module is password-protected, anyone who attempts to connect with the S7-200 CPU through the Modem module is required to supply the correct password. Select password protection if desired, and enter a password. Click Next>.
4. The Modem module supports two communications protocols: PPI protocol (to communicate with STEP 7–Micro/WIN), and Modbus RTU protocol. Protocol selection is dependent on the type of device that is being used as the remote communications partner. This setting controls the communications protocol used when the Modem module answers a call and also when the Modem module initiates a CPU data transfer. Select the appropriate protocol and click Next>.

5. You can configure the module to send numeric and text messages to pagers, or Short Message Service (SMS) messages to cellular telephones. Check the Enable messaging checkbox and click the Configure Messaging... button to define messages and the recipient's telephone numbers.
6. When setting up a message to be sent to a pager or cellular phone, you must define the message and the telephone number. Select the Messages tab on the Configure Messaging screen and click the New Message button. Enter the text for the message and specify any CPU data values to insert into the message. To insert a CPU data value into the message, move the cursor to the position for the data and click the Insert Data... button. Specify the address of the CPU data value (i.e. VW100), the display format (i.e. Signed Integer) and the digits left and right of the decimal point. You can also specify if the decimal point should be a comma or a period.
 - Numeric paging messages are limited to the digits 0 to 9, the letters A, B, C and D, and the asterisk (*). The maximum allowed length of a numeric paging message varies by service provider.
 - Text messages can be up to 119 characters in length and contain any alphanumeric character.
 - Text messages can contain any number of embedded variables.
 - Embedded variables can be from V, M, SM, I, Q, S, T, C or AI memory in the attached CPU.
 - Hexadecimal data is displayed with a leading '16#'. The number of characters in the value is based on the size of the variable. For example, VW100 displays as 16#0123.
 - The number of digits left of the decimal must be large enough to display the expected range of values, including the negative sign, if the data value is a signed integer or floating point value.
 - If the data format is integer and the number of digits right of the decimal point is not zero, the integer value is displayed as a scaled integer. For example, if VW100 = 1234 and there are 2 digits right of the decimal point, the data is displayed as '12.34'.
 - If the data value is greater than can be displayed in the specified field size, the Modem module places the # character in all character positions of data value.
7. Telephone numbers are configured by selecting the Phone Numbers tab on the Configure Messaging screen. Click the New Phone Number... button to add a new telephone number. Once a telephone number has been configured it must be added to the project. Highlight the telephone number in the Available Phone Numbers column and click the right arrow box to add the telephone number to the current project. Once you have added the telephone number to the current project, you can select the telephone number and add a symbolic name for this number to use in your program.

The telephone number consists of several fields which vary based on the type of messaging selected by the user.

- The Messaging Protocol selection tells the Modem module which protocol to use when sending the message to the message service provider. Numeric pagers support only numeric protocol. Text paging services usually require TAP (Telelocator Alphanumeric Protocol). SMS messaging providers are supported with either TAP or UCP (Universal Computer Protocol). There are three different UCP services normally used for SMS messaging. Most providers support command 1 or 51. Check with the SMS provider to determine the protocol and commands required by that provider.
- The Description field allows you to add a text description for the telephone number.

- The Phone Number field is the telephone number of the messaging service provider. For text messages this is the telephone number of the modem line the service provider uses to accept text messages. For numeric paging this is the telephone number of the pager itself. The Modem module allows the telephone number field to be a maximum of 40 characters. The following characters are allowed in telephone numbers that the Modem module uses to dial out:

0 to 9	allowed from a telephone keypad
A, B, C, D, *, #	DTMF digits (tone dialing only)
,	pause dialing for 2 seconds
!	commands the modem to generate a hook flash
@	wait for 5 seconds of silence
W	wait for a dial tone before continuing
()	ignored (can be used to format the telephone number)
- The Specific Pager ID or Cell Phone Number field is where you enter the pager number or cellular telephone number of the message recipient. This number should not contain any characters except the digits 0 through 9. A maximum of 20 characters is allowed.
- The Password field is optional for TAP message. Some providers require a password but normally this field should be left blank. The Modem module allows the password to be up to 15 characters.
- The Originating Phone Number field allows the Modem module to be identified in the SMS message. This field is required by some service providers which use UCP commands. Some service providers might require a minimum number of characters in this field. The Modem module allows up to 15 characters.
- The Modem Standard field is provided for use in cases where the Modem module and the service provider modem cannot negotiate the modem standard. The default is V.34 (33.6 kBaud).
- The Data Format fields allow you to adjust the data bits and parity used by the modem when transmitting a message to a service provider. TAP normally used 7 data bits and even parity, but some service providers use 8 data bits and no parity. UCP always uses 8 data bits with no parity. Check with the service provider to determine which settings to use.

8. You can configure the Modem module to transfer data to another S7-200 CPU (if PPI protocol was selected) or to transfer data to a Modbus device (if Modbus protocol was selected). Check the Enable CPU data transfers checkbox and click the Configure CPU-to... button to define the data transfers and the telephone numbers of the remote devices.
9. When setting up a CPU-to-CPU or a CPU-to-Modbus data transfer you must define the data to transfer and the telephone number of the remote device. Select the Data Transfers tab on the Configure Data Transfers screen and click the New Transfer button. A data transfer consists of a data read from the remote device, a data write to the remote device, or both a read from and a write to the remote device. If both a read and a write are selected, the read is performed first and then the write.

Up to 100 words can be transferred in each read or write. Data transfers must be to or from the V Memory in the local CPU. The wizard always describes the memory locations in the remote device as if the remote device is an S7-200 CPU. If the remote device is a Modbus device, the transfer is to or from holding registers in the Modbus device (address 04xxxx). The equivalent Modbus address (xxxx) is determined as follows:

$$\begin{aligned} \text{Modbus address} &= 1 + (\text{V memory address} / 2) \\ \text{V memory address} &= (\text{Modbus address} - 1) * 2 \end{aligned}$$

10. The Phone Numbers tab on the Configure CPU Data Transfers screen allows you to define the telephone numbers for CPU-to-CPU or a CPU-to-Modbus data transfers. Click the New Phone Number... button to add a new telephone number. Once a telephone number has been configured it must be added to the project. Highlight the telephone number in the Available Phone Numbers column and click the right arrow box to add the telephone number to the current project. Once you have added the telephone number to the current project, you can select the telephone number and add a symbolic name for this telephone number to use in your program.

The Description and Phone Number fields are the same as described earlier for messaging. The Password field is required if the remote device is a Modem module and password protection has been enabled. The Password field in the local Modem module must be set to the password of the remote Modem module. The local Modem module supplies this password when it is requested by the remote Modem module.

11. Callback causes the Modem module to automatically disconnect and dial a predefined telephone number after receiving an incoming call from a remote STEP 7–Micro/WIN. Select the Enable callback checkbox and click the Configure Callback... button to configure callback telephone numbers. Click Next>.
12. The Configure Callback... screen allows you enter the telephone numbers the Modem module uses when it answers an incoming call. Check the 'Enable callbacks to only specified phone numbers' if the callback numbers are to be predefined. If the Modem module is to accept any callback number supplied by the incoming caller (to reverse the connection charges), check the 'Enable callbacks to any phone number' selection.

If only specified callback telephone numbers are allowed, click the New Phone Number button to add callback telephone numbers. The Callback Properties screen allows you to enter the predefined callback telephone numbers and a description for the callback number. The callback number entered here is the telephone number that the Modem module uses to dial when performing the callback. This telephone number should include all digits required to connect to an outside line, pause while waiting for an outside line, connect to long distance, etc.

After entering a new callback telephone number, it must be added to the project. Highlight the telephone number in the Available Callback Phone Numbers column and click the right arrow box to add the telephone number to the current project.

13. You can set the number of dialing attempts that the Modem module makes when sending a message or during a data transfer. The Modem module reports an error to the user program only when all attempts to dial and send the message are unsuccessful.

Some telephone lines do not have a dial tone present when the telephone receiver is lifted. Normally, the Modem module returns an error to the user program if a dial tone is not present when the Modem module is commanded to send a message or perform a callback. To allow dialing out on a line with no dial tone, check the box, Enable Dialing Without Dial Tone Selection.

14. The Modem Expansion wizard creates a configuration block for the Modem module and requires the user to enter the starting memory address where the Modem module configuration data is stored. The Modem module configuration block is stored in V Memory in the CPU. STEP 7–Micro/WIN writes the configuration block to the project Data Block. The size of the configuration block varies based on the number of messages and telephone numbers configured. You can select the V Memory address where you want the configuration block stored, or click the Suggest Address button if you want the wizard to suggest the address of an unused V Memory block of the correct size. Click Next>.
15. The final step in configuring the Modem module is to specify the Q memory address of the command byte for the Modem module. You can determine the Q memory address by counting the output bytes used by any modules with discrete outputs installed on the S7-200 before the Modem module. Click Next>.
16. The Modem Expansion wizard now generates the project components for your selected configuration (program block and data block) and makes that code available for use by your program. The final wizard screen displays your requested configuration project components. You must download the Modem module configuration block (Data Block) and the Program Block to the S7-200 CPU.

Overview of Modem Instructions and Restrictions

The Modem Expansion wizard makes controlling the Modem module easier by creating unique instruction subroutines based on the position of the module and configuration options you selected. Each instruction is prefixed with a "MODx_" where x is the module location.

Requirements for Using the EM 241 Modem Module Instructions

Consider these requirements when you use Modem module instructions:

- The Modem module instructions use three subroutines.
- The Modem module instructions increase the amount of memory required for your program by up to 370 bytes. If you delete an unused instruction subroutine, you can rerun the Modem Expansion wizard to recreate the instruction if needed.
- You must make sure that only one instruction is active at a time.
- The instructions cannot be used in an interrupt routine.
- The Modem module reads the configuration table information when it first powers up and after a STOP-to-RUN transition. Any change that your program makes to the configuration table is not seen by the module until a mode change or the next power cycle.

Using the EM 241 Modem Module Instructions

To use the Modem module instructions in your S7-200 program, follow these steps:

1. Use the Modem Expansion wizard to create the Modem module configuration table.
2. Insert the MODx_CTRL instruction in your program and use the SM0.0 contact to execute it every scan.
3. Insert a MODx_MSG instruction for each message you need to send.
4. Insert a MODx_XFR instruction for each data transfer.

Instructions for the Modem Module

MODx_CTRL Instruction

The MODx_CTRL (Control) instruction is used to enable and initialize the Modem module. This instruction should be called every scan and should only be used once in the project.

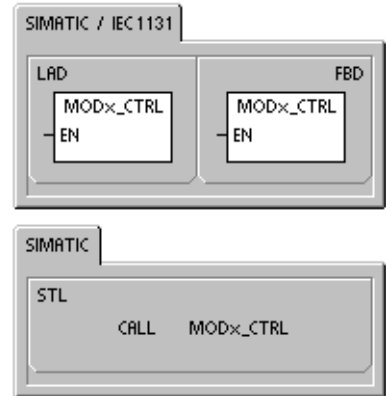

MODx_XFR Instruction

The MODx_XFR (Data Transfer) instruction is used to command the Modem module to read and write data to another S7-200 CPU or a Modbus device. This instruction requires 20 to 30 seconds from the time the START input is triggered until the Done bit is set.

The EN bit must be on to enable a command to the module, and should remain on until the Done bit is set, signaling completion of the process. An XFR command is sent to the Modem module on each scan when START input is on and the module is not currently busy. The START input can be pulsed on through an edge detection element, which only allows one command to be sent.

Phone is the number of one of the data transfer telephone numbers. You can use the symbolic name you assigned to each data transfer telephone number when the number was defined with the Modem Expansion wizard.

Data is the number of one of the defined data transfers. You can use the symbolic name you assigned to the data transfer when the request was defined using the Modem Expansion wizard.

Done is a bit that comes on when the Modem module completes the data transfer.

Error is a byte that contains the result of the data transfer. Table 10-4 defines the possible error conditions that could result from executing this instruction.

Table 10-6 Parameters for the MODx_XFR Instruction

Inputs/Outputs	Data Type	Operands
START	BOOL	I, Q, M, S, SM, T, C, V, L, Power Flow
Phone, Data	BYTE	VB, IB, QB, MB, SB, SMB, LB, AC, Constant, *VD, *AC, *LD
Done	BOOL	I, Q, M, S, SM, T, C, V, L
Error	BYTE	VB, IB, QB, MB, SB, SMB, LB, AC, *VD, *AC, *LD

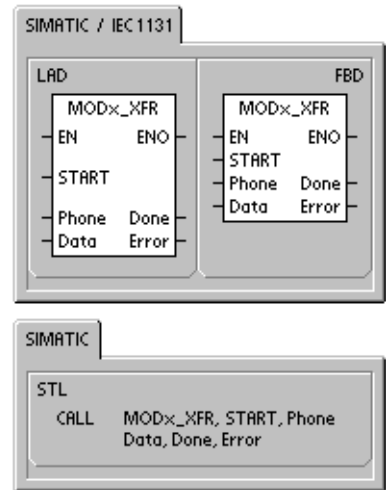

MODx_MSG Instruction

The MODx_MSG (Send Message) instruction is used to send a paging or SMS message from Modem module. This instruction requires 20 to 30 seconds from the time the START input is triggered until the Done bit is set.

The EN bit must be on to enable a command to the module, and should remain on until the Done bit is set, signaling completion of the process. A MSG command is sent to the Modem module on each scan when START input is on and the module is not currently busy. The START input can be pulsed on through an edge detection element, which only allows one command to be sent.

Phone is the number of one of the message telephone numbers. You can use the symbolic name you assigned to each message telephone number the when the number was defined with the Modem Expansion wizard.

Msg is the number of one of the defined messages. You can use the symbolic name you assigned to the message when the message was defined using the Modem Expansion wizard.

Done is a bit that comes on when the Modem module completes the sending of the message to the service provider.

Error is a byte that contains the result of this request to the module. Table 10-8 defines the possible error conditions that could result from executing this instruction.

Table 10-7 Parameters for the MODx_MSG Instruction

Inputs/Outputs	Data Type	Operands
START	BOOL	I, Q, M, S, SM, T, C, V, L, Power Flow
Phone, Msg	BYTE	VB, IB, QB, MB, SB, SMB, LB, AC, Constant, *VD, *AC, *LD
Done	BOOL	I, Q, M, S, SM, T, C, V, L
Error	BYTE	VB, IB, QB, MB, SB, SMB, LB, AC, *VD, *AC, *LD

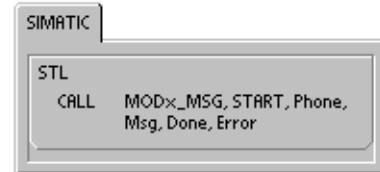
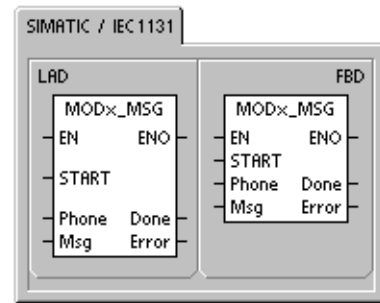

Table 10-8 Error Values Returned by MODx_MSG and MODx_XFR Instructions

Error	Description
0	No error
Telephone line errors	
1	No dial tone present
2	Busy line
3	Dialing error
4	No answer
5	Connect timeout (no connection within 1 minute)
6	Connection aborted or an unknown response
Errors in the command	
7	Numeric paging message contains illegal digits
8	Telephone number (Phone input) out of range
9	Message or data transfer (Msg or Data input) out of range
10	Error in text message or data transfer message
11	Error in messaging or data transfer telephone number
12	Operation not allowed (i.e. attempts set to zero)
Service provider errors	
13	No response (timeout) from messaging service
14	Message service disconnected for unknown reason
15	User aborted message (disabled command bit)
TAP – Text paging and SMS message errors returned by service provider	
16	Remote disconnect received (service provider aborted session)
17	Login not accepted by message service (incorrect password)
18	Block not accepted by message service (checksum or transmission error)
19	Block not accepted by message service (unknown reason)
UCP – SMS message errors returned by service provider	
20	Unknown error
21	Checksum error
22	Syntax error
23	Operation not supported by system (illegal command)
24	Operation not allowed at this time
25	Call barring active (blacklist)
26	Caller address invalid
27	Authentication failure
28	Legitimization code failure
29	GA not valid
30	Repetition not allowed
31	Legitimization code for repetition, failure
32	Priority call not allowed
33	Legitimization code for priority call, failure
34	Urgent message not allowed
35	Legitimization code for urgent message, failure
36	Reverse charging not allowed
37	Legitimization code for reverse charging, failure

Table 10-8 Error Values Returned by MODx_MSG and MODx_XFR Instructions, continued

Error	Description
UCP – SMS message errors returned by service provider (continued)	
38	Deferred delivery not allowed
39	New AC not valid
40	New legitimization code not allowed
41	Standard text not valid
42	Time period not valid
43	Message type not supported by system
44	Message too long
45	Requested standard text not valid
46	Message type not valid for pager type
47	Message not found in SMSC
48	Reserved
49	Reserved
50	Subscriber hang up
51	Fax group not supported
52	Fax message type not supported
Data transfer errors	
53	Message timeout (no response from remote device)
54	Remote CPU busy with upload or download
55	Access error (memory out of range, illegal data type)
56	Communications error (unknown response)
57	Checksum or CRC error in response
58	Remote EM 241 set for callback (not allowed)
59	Remote EM 241 rejected the provided password
60 to 127	Reserved
Instruction use errors	
128	Cannot process this request. Either the Modem module is busy with another request, or there was no START pulse on this request.
129	Modem module error: <ul style="list-style-type: none"> ■ The location of the Modem module or the Q memory address that was configured with the Modem Expansion wizard does not match the actual location or memory address ■ Refer to SMB8 to SMB21 (I/O Module ID and Error Register)

Sample Program for the Modem Module

Example: Modem Module	
<p>Network 1</p> <p>Network 2</p> <p>Network 3</p>	<pre> Network 1 // Call the MOD0_CTRL subroutine // on every scan. LD SM0.0 CALL MOD0_CTRL, M0.0, VB10 Network 2 // Send a text message to a cell phone. LD I0.0 EU = L63.7 LD I0.0 CALL MOD0_MSG, L63.7, CellPhone, Message1, M0.0, VB10 Network 3 // Transfer data to a remote CPU. LD I0.1 EU = L63.7 LD I0.1 CALL MOD0_XFR, L63.7, RemoteCPU, Transfer1, M0.0, VB10 </pre>

S7-200 CPUs that Support Intelligent Modules

The Modem module is an intelligent expansion module designed to work with the S7-200 CPUs shown in Table 10-9.

Table 10-9 EM 241 Modem Module Compatibility with S7-200 CPUs

CPU	Description
CPU 222 Rel. 1.10 or greater	CPU 222 DC/DC/DC
	CPU 222 AC/DC/Relay
CPU 224 Rel. 1.10 or greater	CPU 224 DC/DC/DC
	CPU 224 AC/DC/Relay
CPU 226 Rel. 1.00 or greater	CPU 226 DC/DC/DC
	CPU 226 AC/DC/Relay
CPU 226XM Rel. 1.00 or greater	CPU 226XM DC/DC/DC
	CPU 226XM AC/DC/Relay

Special Memory Location for the Modem Module

Fifty bytes of special memory (SM) are allocated to each intelligent module based on its physical position in the I/O expansion bus. When an error condition or a change in status is detected, the module indicates this by updating the SM locations corresponding to the module's position. If it is the first module, it updates SMB200 through SMB249 as needed to report status and error information. If it is the second module, it updates SMB250 through SMB299, and so on. See Table 10-10.

Table 10-10 Special Memory Bytes SMB200 to SMB549

Special Memory Bytes SMB200 to SMB549						
Intelligent Module in Slot 0	Intelligent Module in Slot 1	Intelligent Module in Slot 2	Intelligent Module in Slot 3	Intelligent Module in Slot 4	Intelligent Module in Slot 5	Intelligent Module in Slot 6
SMB200 to SMB249	SMB250 to SMB299	SMB300 to SMB349	SMB350 to SMB399	SMB400 to SMB449	SMB450 to SMB499	SMB500 to SMB549

Table 10-11 shows the Special Memory data area allocated for the Modem module. This area is defined as if this were the intelligent module located in Slot 0 of the I/O system.

Table 10-11 SM Locations for the EM 241 Modem Module

SM Address	Description																																				
SMB200 to SMB215	Module name (16 ASCII characters) SMB200 is the first character. "EM241 Modem"																																				
SMB216 to SMB219	S/W revision number (4 ASCII characters) SMB216 is the first character.																																				
SMW220	Error code 0000 – No error 0001 – No user power 0002 – Modem failure 0003 – No configuration block ID 0004 – Configuration block out of range 0005 – Configuration error 0006 – Country code selection error 0007 – Phone number too large 0008 – Message too large 0009 to 00FF – Reserved 01xx – Error in callback number xx 02xx – Error in pager number xx 03xx – Error in message number xx 0400 to FFFF – Reserved																																				
SMB222	Module status – reflects the LED status <table style="margin-left: auto; margin-right: auto; border-collapse: collapse;"> <tr> <td style="text-align: center;">MSB</td> <td style="text-align: center;">7</td> <td style="text-align: center;">6</td> <td style="text-align: center;">5</td> <td style="text-align: center;">4</td> <td style="text-align: center;">3</td> <td style="text-align: center;">2</td> <td style="text-align: center;">1</td> <td style="text-align: center;">LSB</td> </tr> <tr> <td style="text-align: center;">F</td> <td style="text-align: center;">G</td> <td style="text-align: center;">H</td> <td style="text-align: center;">T</td> <td style="text-align: center;">R</td> <td style="text-align: center;">C</td> <td style="text-align: center;">0</td> <td style="text-align: center;">0</td> <td></td> </tr> </table> <table style="margin-left: auto; margin-right: auto; border-collapse: collapse;"> <tr> <td style="padding-right: 20px;">F – EM_FAULT</td> <td style="padding-right: 20px;">0 – no fault</td> <td>1 – fault</td> </tr> <tr> <td style="padding-right: 20px;">G – EM_GOOD</td> <td style="padding-right: 20px;">0 – not good</td> <td>1 – good</td> </tr> <tr> <td style="padding-right: 20px;">H – OFF_HOOK</td> <td style="padding-right: 20px;">0 – on hook,</td> <td>1 – off hook</td> </tr> <tr> <td style="padding-right: 20px;">T – NO_DIALTONE</td> <td style="padding-right: 20px;">0 – dial tone</td> <td>1 – no dial tone</td> </tr> <tr> <td style="padding-right: 20px;">R – RING</td> <td style="padding-right: 20px;">0 – not ringing</td> <td>1 – phone ringing</td> </tr> <tr> <td style="padding-right: 20px;">C – CONNECT</td> <td style="padding-right: 20px;">0 – not connected</td> <td>1 – connected</td> </tr> </table>	MSB	7	6	5	4	3	2	1	LSB	F	G	H	T	R	C	0	0		F – EM_FAULT	0 – no fault	1 – fault	G – EM_GOOD	0 – not good	1 – good	H – OFF_HOOK	0 – on hook,	1 – off hook	T – NO_DIALTONE	0 – dial tone	1 – no dial tone	R – RING	0 – not ringing	1 – phone ringing	C – CONNECT	0 – not connected	1 – connected
MSB	7	6	5	4	3	2	1	LSB																													
F	G	H	T	R	C	0	0																														
F – EM_FAULT	0 – no fault	1 – fault																																			
G – EM_GOOD	0 – not good	1 – good																																			
H – OFF_HOOK	0 – on hook,	1 – off hook																																			
T – NO_DIALTONE	0 – dial tone	1 – no dial tone																																			
R – RING	0 – not ringing	1 – phone ringing																																			
C – CONNECT	0 – not connected	1 – connected																																			
SMB223	Country code as set by switches (decimal value)																																				
SMW224	Baud rate at which the connection was established (unsigned decimal value).																																				

Table 10-11 SM Locations for the EM 241 Modem Module, continued

SM Address	Description												
SMB226	<p>Result of the user command</p> <div style="text-align: center;"> <table style="margin-left: auto; margin-right: auto;"> <tr> <td style="text-align: center;">MSB</td> <td style="text-align: center;">7</td> <td style="text-align: center;">6</td> <td style="text-align: center;">5</td> <td style="text-align: center;">LSB</td> <td style="text-align: center;">0</td> </tr> <tr> <td style="border: 1px solid black; padding: 2px;">D</td> <td style="border: 1px solid black; padding: 2px;">0</td> <td colspan="4" style="border: 1px solid black; padding: 2px;">ERROR</td> </tr> </table> </div> <p>D – Done bit; 0 – operation in progress 1 – operation complete</p> <p>ERROR : Error Code Description, see Table 10-8</p>	MSB	7	6	5	LSB	0	D	0	ERROR			
MSB	7	6	5	LSB	0								
D	0	ERROR											
SMB227	Telephone number selector – This byte specifies which messaging telephone number to use when sending a message. Valid values are 1 through 250.												
SMB228	Message selector – This byte specifies which message to send. Valid values are 1 through 250.												
SMB229 to SMB244	Reserved												
SMB245	Offset to the first Q byte used as the command interface to this module. The offset is supplied by the CPU for the convenience of the user and is not needed by the module.												
SMD246	Pointer to the configuration table for the Modem module in V memory. A pointer value to an area other than V memory is not accepted and the module continues to examine this location, waiting for a non-zero pointer value.												

Advanced Topics

Understanding the Configuration Table

The Modem Expansion wizard has been developed to make modem applications easy by automatically generating the configuration table based upon the answers you give about your system. Configuration table information is provided for advanced users who want to create their own Modem module control routines and format their own messages.

The configuration table is located in the V memory area of the S7-200. In Table 10-12, the Byte Offset column of the table is the byte offset from the location pointed to by the configuration area pointer in SM memory. The configuration table information is divided into four sections.

- The Configuration Block contains information to configure the module.
- The Callback Telephone Number Block contains the predefined telephone numbers allowed for callback security.
- The Message Telephone Number Block contains the telephone numbers used when dialing messaging services or CPU data transfers.
- The Message Block contains the predefined messages to send to the messaging services.

Table 10-12 Configuration Table for the Modem Module

Configuration Block																					
Byte Offset	Description																				
0 to 4	Module Identification – Five ASCII characters used for association of the configuration table to an intelligent module. Release 1.00 of the EM 241 Modem module expects "M241A".																				
5	The length of the Configuration Block – Currently 24.																				
6	Callback telephone number length – Valid values are 0 through 40.																				
7	Messaging telephone number length – Valid values are 0 through 120.																				
8	Number of callback telephone numbers – Valid values are 0 through 250.																				
9	Number of messaging telephone numbers – Valid values are 0 through 250.																				
10	Number of messages – Valid values are 0 through 250.																				
11 to 12	Reserved (2 bytes)																				
13	<p>This byte contains the enable bits for the features supported.</p> <table style="margin-left: 40px; border-collapse: collapse;"> <tr> <td style="padding: 0 5px;">MSB</td> <td style="padding: 0 5px;">7</td> <td style="padding: 0 5px;">6</td> <td style="padding: 0 5px;">5</td> <td style="padding: 0 5px;">4</td> <td style="padding: 0 5px;">3</td> <td style="padding: 0 5px;">2</td> <td style="padding: 0 5px;">1</td> <td style="padding: 0 5px;">LSB</td> <td style="padding: 0 5px;">0</td> </tr> <tr> <td style="border: 1px solid black; text-align: center; width: 20px;">PD</td> <td style="border: 1px solid black; text-align: center; width: 20px;">CB</td> <td style="border: 1px solid black; text-align: center; width: 20px;">PW</td> <td style="border: 1px solid black; text-align: center; width: 20px;">MB</td> <td style="border: 1px solid black; text-align: center; width: 20px;">BD</td> <td style="border: 1px solid black; text-align: center; width: 20px;">0</td> <td style="border: 1px solid black; text-align: center; width: 20px;">0</td> <td style="border: 1px solid black; text-align: center; width: 20px;">0</td> <td></td> <td></td> </tr> </table> <p style="margin-left: 40px;"> PD – 0 = tone dialing 1 = pulse dialing CB – 0 = callback disabled 1 = callback enabled PW – 0 = password disabled 1 = password enabled MB – 0 = PPI protocol enabled 1 = Modbus protocol enabled BD – 0 = blind dialing disabled 1 = blind dialing enabled Bits 2, 1 and 0 are ignored by the module </p>	MSB	7	6	5	4	3	2	1	LSB	0	PD	CB	PW	MB	BD	0	0	0		
MSB	7	6	5	4	3	2	1	LSB	0												
PD	CB	PW	MB	BD	0	0	0														
14	Reserved																				
15	Attempts – This value specifies the number of times the modem is to attempt to dial and send a message before returning an error. A value of 0 prevents the modem from dialing out.																				
16 to 23	Password – Eight ASCII characters																				

Table 10-12 Configuration Table for the Modem Module, continued

Callback Telephone Number Block (optional)	
Byte Offset	Description
24	Callback Telephone Number 1 – A string representing the first telephone number that is authorized for callback access from the EM 241 Modem module. Each callback telephone number must be allocated the same amount of space as specified in the callback telephone number length field (offset 6 in the Configuration Block).
24+ callback number	Callback Telephone Number 2
:	:
:	Callback Telephone Number n
Messaging Telephone Number Block (optional)	
Byte Offset	Description
M	Messaging Telephone Number 1 – A string representing a messaging telephone number which includes protocol and dialing options. Each telephone number must be allocated the same amount of space as specified in the messaging telephone number length field (offset 7 in the Configuration Block). The messaging telephone number format is described below
M + messaging number length	Messaging Telephone Number 2
:	:
:	Messaging Telephone Number n
Message Block (optional)	
Byte Offset	Description
N	V memory offset (relative to VB0) for the first message (2 bytes)
N+2	Length of message 1
N+3	Length of message 2
:	:
:	Length of message n
P	Message 1 – A string (120 bytes max.) representing the first message. This string includes text and embedded variable specifications or it could specify a CPU data transfer. See the Text Message Format and the CPU Data Transfer Format described below.
P + length of message 1	Message 2
:	:
:	Message n

The Modem module re-reads the configuration table when these events occur:

- Within five seconds of each STOP-to-RUN transition of the S7-200 CPU (unless the modem is currently online)
- Every five seconds until a valid configuration is found (unless the modem is currently online)
- Every time the modem transitions from an online to an offline condition

Messaging Telephone Number Format

The Messaging Telephone Number is a structure which contains the information needed by the Modem module to send a message. The Messaging Telephone Number is an ASCII string with a leading length byte followed by ASCII characters. The maximum length of a Messaging Telephone Number is 120 bytes (which includes the length byte).

The Messaging Telephone Number contains up to 6 fields separated by a forward slash (/) character. Back-to-back slashes indicate an empty (null) field. Null fields are set to default values in the Modem module.

Format: <Telephone Number>/<ID>/<Password>/<Protocol>/<Standard>/<Format>

The Telephone Number field is the telephone number that the Modem module dials when sending a message. If the message being sent is a text or SMS message, this is the telephone number of the service provider. If the message is a numeric page, this field is the pager telephone number. If the message is a CPU data transfer, this is the telephone number of the remote device. The maximum number of characters in this field is 40.

The ID is the pager number or cellular telephone number. This field should consist of the digits 0 to 9 only. If the protocol is a CPU data transfer, this field is used to supply the address of the remote device. Up to 20 characters are allowed in this field.

The Password field is used to supply the a password for messages sent via TAP if a password is required by the service provider. For messages sent via UCP this field is used as the originating address or telephone number. If the message is a CPU data transfer to another Modem module, this field can be used to supply the password of the remote Modem module. The password can be up to 15 characters in length.

The Protocol field consists of one ASCII character which tells the Modem module how it should format and transmit the message. The following values are allowed:

- 1 – Numeric paging protocol (default)
- 2 – TAP
- 3 – UCP command 1
- 4 – UCP command 30
- 5 – UCP command 51
- 6 – CPU data transfer

The Standard field forces the Modem module to use a specific modem standard. The standard field is one ASCII character. The following values are allowed:

- 1 – Bell 103
- 2 – Bell 212
- 3 – V.21
- 4 – V.22
- 5 – V.22 bit
- 6 – V.23c
- 7 – V.32
- 8 – V.32 bit
- 9 – V.34 (default)

The Format field is three ASCII characters which specify the number of data bits and parity to be used when transmitting the message. This field does not apply if the protocol is set to numeric paging. Only the following two settings are allowed:

- 8N1 – 8 data bits, no parity, one stop bit (default)
- 7E1 – 7 data bits, even parity, one stop bit

Text Message Format

The Text Message Format defines the format of text paging or SMS messages. These types of messages can contain text and embedded variables. The text message is an ASCII string with a leading length byte followed by ASCII characters. The maximum length of a text message is 120 bytes (which includes the length byte).

Format: <Text><Variable><Text><Variable>...

The Text field consists of ASCII characters.

The Variable field defines an embedded data value which the Modem module reads from the local CPU, formats, and places in the message. The percent (%) character is used to mark the start and the end of a variable field. The address and the left fields are separated with a colon. The delimiter between the Left and Right fields can be either a period or a comma and is used as the decimal point in the formatted variable. The syntax for the variable field is:

%Address:Left.Right Format%

The Address field specifies the address, data type and size of the embedded data value (i.e. VD100, VW50, MB20 or T10). The following data types are allowed: I, Q, M, S, SM, V, T, C, and AI. Byte, word and double word sizes are allowed.

The Left field defines the number of digits to display left of the decimal point. This value should be large enough to handle the expected range of the embedded variable including a minus sign if needed. If Left is zero the value is displayed with a leading zero. The valid range for Left is 0 to 10.

The Right field defines the number of digits to display right of the decimal point. Zeros to the right of the decimal point are always displayed. If Right is zero the number is displayed without a decimal point. The valid range for Right is 0 to 10.

The Format field specifies the display format of the embedded value. The following characters are allowed for the format field:

- i – signed integer
- u – unsigned integer
- h – hexadecimal
- f – floating point/real

Example: "Temperature = %VW100:3.1i% Pressure = %VD200:4.3f%"

CPU Data Transfer Message Format

A CPU data transfer, either a CPU-to-CPU or a CPU-to-Modbus data transfer, is specified using the CPU Data Transfer Message Format. A CPU Data Transfer Message is an ASCII string which can specify any number of data transfers between devices, up to the number of specifications that fit in the maximum message length of 120 bytes (119 characters plus a length byte). An ASCII space can be used to separate the data transfer specifications, but is not required. All data transfer specifications are executed within one connection. Data transfers are executed in the order defined in the message. If an error is detected in a data transfer, the connection to the remote device is terminated and subsequent transactions are not processed.

If the operation is specified as a read, Count number of words are read from the remote device starting at the Remote_address, and then written to V Memory in the local CPU starting at the Local_address.

If the operation is specified as a write, Count number of words are read from the local CPU starting at the Local_address, and then written to the remote device starting at Remote_address.

Format: <Operation>=<Count>,<Local_address>,<Remote_address>

The Operation field consists of one ASCII character and defines the type of transfer.

R – Read data from the remote device
W – Write data to the remote device

The Count field specifies the number of words to be transferred. The valid range for the count field is 1 to 100 words.

The Local_address field specifies the V Memory address in the local CPU for the data transfer (i.e. VW100).

The Remote_address field specifies the address in the remote device for the data transfer (i.e. VW500). This address is always specified as a V Memory address even if the data transfer is to a Modbus device. If the remote device is a Modbus device, the conversion between V Memory address and Modbus address is as follows:

$$\begin{aligned}\text{Modbus address} &= 1 + (\text{V Memory address} / 2) \\ \text{V Memory address} &= (\text{Modbus address} - 1) * 2\end{aligned}$$

Example: R=20,VW100, VW200 W=50,VW500,VW1000 R=100,VW1000,VW2000

Using the USS Protocol Library to Control a MicroMaster Drive



STEP 7–Micro/WIN Instruction Libraries makes controlling MicroMaster drives easier by including preconfigured subroutines and interrupt routines that are specifically designed for using the USS protocol to communicate with the drive. With the USS instructions, you can control the physical drive and the read/write drive parameters.

You find these instructions in the Libraries folder of the STEP 7–Micro/WIN instruction tree. When you select a USS instruction, one or more associated subroutines (USS1 through USS7) are added automatically.

In This Chapter

Requirements for Using the USS Protocol	312
Calculating the Time Required for Communicating with the Drive	313
Using the USS Instructions	314
Instructions for the USS Protocol	315
Sample Programs for the USS Protocol	322
USS Execution Error Codes	323
Connecting and Setting Up the MicroMaster Series 3 Drive	324
Connecting and Setting Up the MicroMaster Series 4 Drive	327

Requirements for Using the USS Protocol

The STEP 7–Micro/WIN Instruction Libraries provides 14 subroutines, 3 interrupt routines, and 8 instructions to support the USS protocol. The USS instructions use the following resources in the S7-200:

- ❑ Initializing the USS protocol dedicates Port 0 for the USS communications.

You use the USS_INIT instruction to select either USS or PPI for Port 0. (USS refers to the USS protocol for SIMOTION MicroMaster drives.) After selecting to use the USS protocol for communicating with drives, you cannot use Port 0 for any other purpose, including communicating with STEP 7–Micro/WIN.

During the development of the program for an application using the USS protocol, you should use a CPU 226, CPU 226XM, or EM 277 PROFIBUS–DP module connected to a PROFIBUS CP card in your computer. This second communications port allows STEP 7–Micro/WIN to monitor the application while USS protocol is running.
- ❑ The USS instructions affect all of the SM locations that are associated with Freeport communications on Port 0.
- ❑ The USS instructions use 14 subroutines and 3 interrupt routines.
- ❑ The USS instructions increase the amount of memory required for your program by up to 3450 bytes. Depending on the specific USS instructions used, the support routines for these instructions can increase the overhead for the control program by at least 2150 bytes, up to 3450 bytes.
- ❑ The variables for the USS instructions require a 400-byte block of V memory. The starting address for this block is assigned by the user and is reserved for USS variables.
- ❑ Some of the USS instructions also require a 16-byte communications buffer. As a parameter for the instruction, you provide a starting address in V memory for this buffer. It is recommended that a unique buffer be assigned for each instance of USS instructions.
- ❑ When performing calculations, the USS instructions use accumulators AC0 to AC3. You can also use the accumulators in your program; however, the values in the accumulators will be changed by the USS instructions.
- ❑ The USS instructions cannot be used in an interrupt routine.

11



Tip

To change the operation of Port 0 back to PPI so that you can communicate with STEP 7–Micro/WIN, use another USS_INIT instruction to reassign Port 0.

You can also set the mode switch on the S7-200 to STOP mode. This resets the parameters for Port 0. Be aware that stopping the communications to the drives also stops the drives.

Calculating the Time Required for Communicating with the Drive

Communications with the drive are asynchronous to the S7-200 scan. The S7-200 typically completes several scans before one drive communications transaction is completed. The following factors help determine the amount of time required: the number of drives present, the baud rate, and the scan time of the S7-200.

Some drives require longer delays when using the parameter access instructions. The amount of time required for a parameter access is dependent on the drive type and the parameter being accessed.

After a USS_INIT instruction assigns Port 0 to use the USS Protocol, the S7-200 regularly polls all active drives at the intervals shown in Table 11-1. You must set the time-out parameter of each drive to allow for this task.

Table 11-1 Communications Times

Baud Rate	Time Between Polls of Active Drives (with No Parameter Access Instructions Active)
1200	240 ms (maximum) times the number of drives
2400	130 ms (maximum) times the number of drives
4800	75 ms (maximum) times the number of drives
9600	50 ms (maximum) times the number of drives
19200	35 ms (maximum) times the number of drives
38400	30 ms (maximum) times the number of drives
57600	25 ms (maximum) times the number of drives
115200	25 ms (maximum) times the number of drives



Tip

Only one USS_RPM_x or USS_WPM_x instruction can be active at a time. The Done output of each instruction should signal completion before user logic initiates a new instruction.

Use only one USS_CTRL instruction for each drive.

Using the USS Instructions

To use the USS protocol instructions in your S7-200 controller program, follow these steps:

1. Insert the USS_INIT instruction in your program and execute the USS_INIT instruction for one scan only. You can use the USS_INIT instruction either to initiate or to change the USS communications parameters.

When you insert the USS_INIT instruction, several hidden subroutines and interrupt routines are automatically added to your program.

2. Place only one USS_CTRL instruction in your program for each active drive.

You can add as many USS_RPM_x and USS_WPM_x instructions as required, but only one of these can be active at a time.

3. Allocate the V memory for the library instructions by right-clicking (to get the menu) on the Program Block node in the instruction tree.

Select the Library Memory option to display the Library Memory Allocation dialog box.

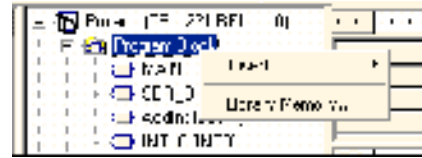

Figure 11-1 Allocating V Memory for the Instruction Library

4. Configure the drive parameters to match the baud rate and address used in the program.

5. Connect the communications cable between the S7-200 and the drives.

Ensure that all of the control equipment, such as the S7-200, that is connected to the drive be connected by a short, thick cable to the same ground or star point as the drive.

Caution

Interconnecting equipment with different reference potentials can cause unwanted currents to flow through the interconnecting cable. These unwanted currents can cause communications errors or damage equipment.

Ensure that all equipment that is connected with a communications cable either shares a common circuit reference or is isolated to prevent unwanted current flows.

The shield must be tied to chassis ground or pin 1 on the 9-pin connector. It is recommended that you tie wiring terminal 2–0V on the MicroMaster drive to chassis ground.

Instructions for the USS Protocol

USS_INIT Instruction

The USS_INIT instruction is used to enable and initialize, or to disable MicroMaster Drive communications. Before any other USS instruction can be used, the USS_INIT instruction must be executed without errors. The instruction completes and the Done bit is set immediately, before continuing to the next instruction.

The instruction is executed on each scan when the EN input is on.

Execute the USS_INIT instruction only once for each change in communications state. Use an edge detection instruction to pulse the EN input on. To change the initialization parameters, execute a new USS_INIT instruction.

The value for Mode selects the communications protocol: an input value of 1 assigns port 0 to USS protocol and enables the protocol, and an input value of 0 assigns port 0 to PPI and disables the USS protocol.

Baud sets the baud rate at 1200, 2400, 4800, 9600, 19200, 38400, 57600, or 115200.

Active indicates which drives are active. Some drives only support addresses 0 through 30.

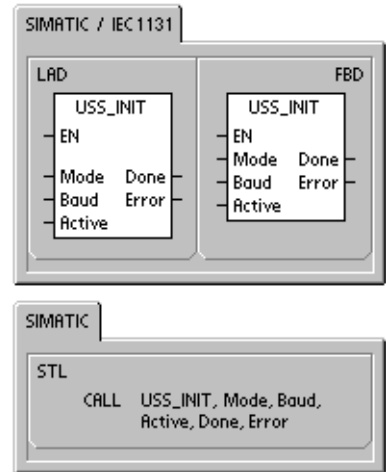
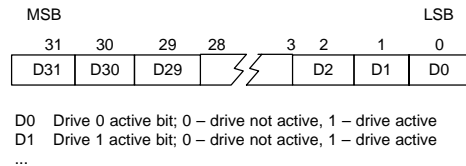

Table 11-2 Parameters for the USS_INIT Instruction

Inputs/Outputs	Data Type	Operands
Mode	BYTE	VB, IB, QB, MB, SB, SMB, LB, AC, Constant, *VD, *AC, *LD
Baud, Active	DWORD	VD, ID, QD, MD, SD, SMD, LD, Constant, AC *VD, *AC, *LD
Done	BOOL	I, Q, M, S, SM, T, C, V, L
Error	BYTE	VB, IB, QB, MB, SB, SMB, LB, AC, *VD, *AC, *LD

Figure 11-2 shows the description and format of the active drive input. Any drive that is marked as Active is automatically polled in the background to control the drive, collect status, and prevent serial link time-outs in the drive.



Refer to Table 11-1 to compute the time between status polls.

Figure 11-2 Format for the Active Drive Parameter

When the USS_INIT instruction completes, the Done output is turned on. The Error output byte contains the result of executing the instruction. Table 11-6 defines the error conditions that could result from executing the instruction.

Example: USS_INIT Subroutine

Network 1

```

LD I0.0
P
USS_INIT
EN
1-Mode Done-M0.0
9600-Baud Error-VB10
16#00000001-Active
                    
```

Network 1

```

LD I0.0
EU
CALL USS_INIT, 1, 9600, 16#00000001, M0.0, VB10
                    
```

USS_CTRL Instruction

The USS_CTRL instruction is used to control an active MicroMaster drive. The USS_CTRL instruction places the selected commands in a communications buffer, which is then sent to the addressed drive (Drive parameter), if that drive has been selected in the Active parameter of the USS_INIT instruction.

Only one USS_CTRL instruction should be assigned to each drive.

Some drives report speed only as a positive value. If the speed is negative, the drive reports the speed as positive but reverses the D_Dir (direction) bit.

The EN bit must be on to enable the USS_CTRL instruction. This instruction should always be enabled.

RUN (RUN/STOP) indicates whether the drive is on (1) or off (0). When the RUN bit is on, the MicroMaster drive receives a command to start running at the specified speed and direction. In order for the drive to run, the following must be true:

- Drive must be selected as Active in USS_INIT.
- OFF2 and OFF3 must be set to 0.
- Fault and Inhibit must be 0.

When RUN is off, a command is sent to the MicroMaster drive to ramp the speed down until the motor comes to a stop. The OFF2 bit is used to allow the MicroMaster drive to coast to a stop. The OFF3 bit is used to command the MicroMaster drive to stop quickly.

The Resp_R (response received) bit acknowledges a response from the drive. All the Active drives are polled for the latest drive status information. Each time the S7-200 receives a response from the drive, the Resp_R bit is turned on for one scan and all the following values are updated.

The F_ACK (fault acknowledge) bit is used to acknowledge a fault in the drive. The drive clears the fault (Fault) when F_ACK goes from 0 to 1.

The DIR (direction) bit indicates in which direction the drive should move.

The Drive (drive address) input is the address of the MicroMaster drive to which the USS_CTRL command is to be sent. Valid addresses: 0 to 31

The Type (drive type) input selects the type of drive. For a MicroMaster 3 (or earlier) drive, set Type to 0. For a MicroMaster 4 drive, set Type to 1.

Table 11-3 Parameters of the USS_CTRL Instruction

Inputs/Outputs	Data Types	Operands
RUN, OFF 2, OFF 3, F_ACK, DIR	BOOL	I, Q, M, S, SM, T, C, V, L, Power Flow
Resp_R, Run_EN, D_Dir, Inhibit, Fault	BOOL	I, Q, M, S, SM, T, C, V, L
Drive, Type	BYTE	VB, IB, QB, MB, SB, SMB, LB, AC, *VD, *AC, *LD, Constant
Error	BYTE	VB, IB, QB, MB, SB, SMB, LB, AC, *VD, *AC, *LD
Status	WORD	VW, T, C, IW, QW, SW, MW, SMW, LW, AC, AQW, *VD, *AC, *LD
Speed_SP	REAL	VD, ID, QD, MD, SD, SMD, LD, AC, *VD, *AC, *LD, Constant
Speed	REAL	VD, ID, QD, MD, SD, SMD, LD, AC, *VD, *AC, *LD

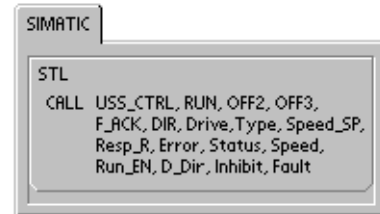
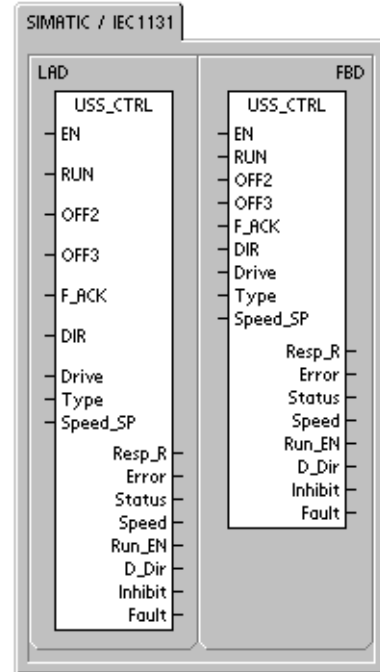

Speed_SP (speed setpoint) is drive speed as a percentage of full speed. Negative values of Speed_SP cause the drive to reverse its direction of rotation. Range: –200.0% to 200.0%

Error is an error byte that contains the result of the latest communications request to the drive. Table 11-6 defines the error conditions that could result from executing the instruction.

Status is the raw value of the status word returned by the drive. Figure 11-3 shows the status bits for Standard Status Word and Main Feedback.

Speed is drive speed as a percentage of full speed. Range: –200.0% to 200.0%

Run_EN (RUN enable) indicates whether the drive is running (1) or stopped (0).

D_Dir indicates the drive's direction of rotation.

Inhibit indicates the state of the inhibit bit on the drive (0 – not inhibited, 1 – inhibited). To clear the inhibit bit, the Fault bit must be off, and the RUN, OFF2, and OFF3 inputs must also be off.

Fault indicates the state of the fault bit (0 – no fault, 1 – fault). The drive displays the fault code. (Refer to the manual for your drive). To clear the Fault bit, correct the cause of the fault and turn on the F_ACK bit.

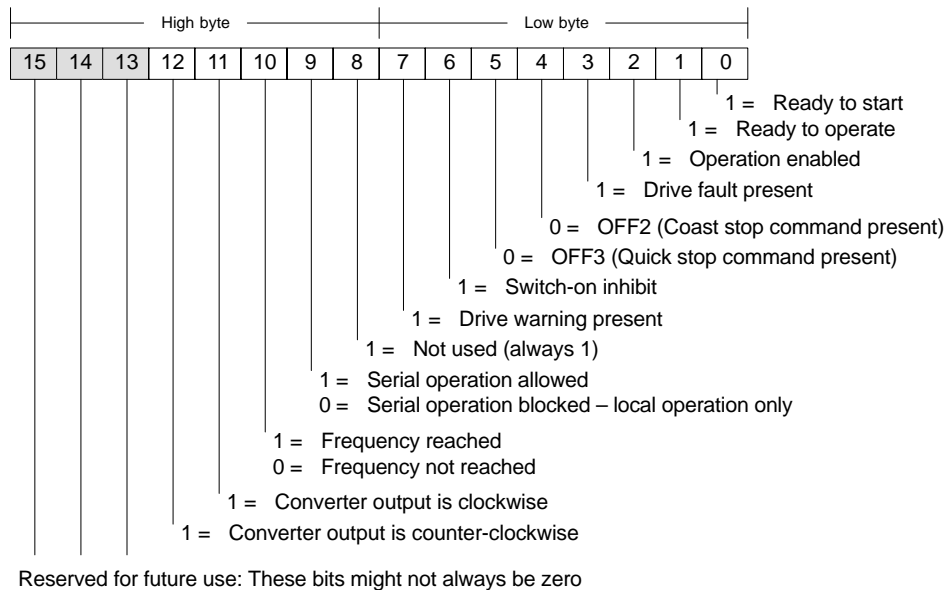

Figure 11-3 Status Bits for Standard Status Word for MicroMaster 3 and Main Feedback

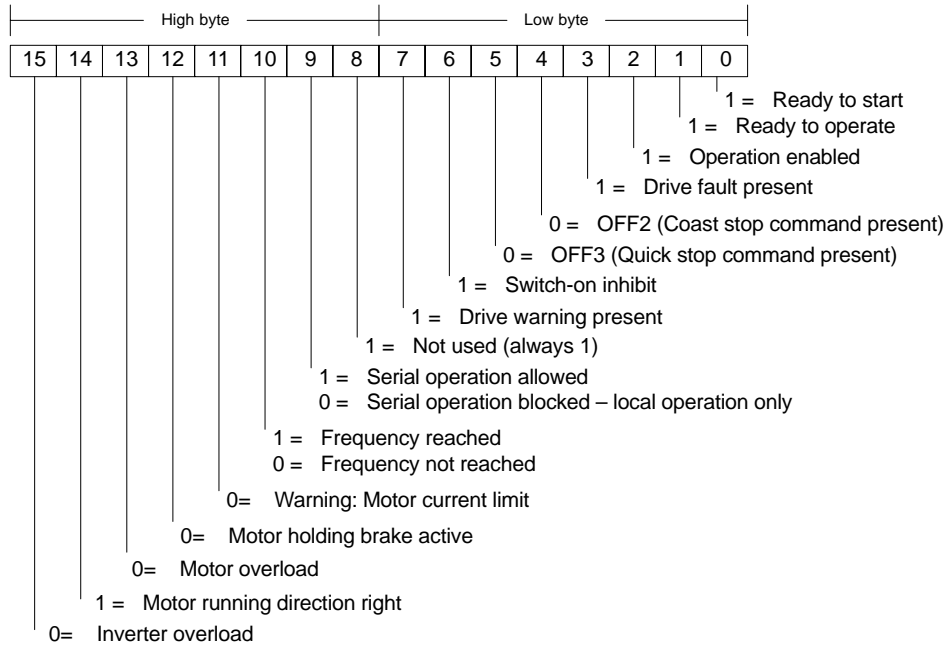

Figure 11-4 Status Bits for Standard Status Word for MicroMaster 4 and Main Feedback

Example: USS_CTRL Subroutine

To display in STL only:

```

Network 1 //Control box for drive 0
LD SM0.0
CALL USS_CTRL, I0.0, I0.1, I0.2, I0.3, I0.4, 0, 1,
100.0, M0.0, VB2, VW4, VD6, Q0.0, Q0.1, Q0.2, Q0.3

```

To display in LAD or FBD:

```

Network 1 //Control box for drive 0
LD SM0.0
= L60.0
LD I0.0
= L63.7
LD I0.1
= L63.6
LD I0.2
= L63.5
LD I0.3
= L63.4
LD I0.4
= L63.3
LD L60.0
CALL USS_CTRL, L63.7, L63.6, L63.5, L63.4,
L63.3, 0, 1, 100.0, M0.0, VB2, VW4, VD6, Q0.0, Q0.1,
Q0.2, Q0.3

```

USS_RPM_x Instruction

There are three read instructions for the USS protocol:

- USS_RPM_W instruction reads an unsigned word parameter.
- USS_RPM_D instruction reads an unsigned double word parameter.
- USS_RPM_R instruction reads a floating-point parameter.

Only one read (USS_RPM_x) or write (USS_WPM_x) instruction can be active at a time.

The USS_RPM_x transactions complete when the MicroMaster drive acknowledges receipt of the command, or when an error condition is posted. The logic scan continues to execute while this process awaits a response.

The EN bit must be on to enable transmission of a request, and should remain on until the Done bit is set, signaling completion of the process. For example, a USS_RPM_x request is transmitted to the MicroMaster drive on each scan when XMT_REQ input is on. Therefore, the XMT_REQ input should be pulsed on through an edge detection element which causes one request to be transmitted for each positive transition of the EN input.

The Drive input is the address of the MicroMaster drive to which the USS_RPM_x command is to be sent. Valid addresses of individual drives are 0 to 31.

Param is the parameter number. Index is the index value of the parameter that is to be read. Value is the parameter value returned. The address of a 16-byte buffer must be supplied to the DB_Ptr input. This buffer is used by the USS_RPM_x instruction to store the results of the command issued to the MicroMaster drive.

When the USS_RPM_x instruction completes, the Done output is turned on and the Error output byte and the Value output contain the results of executing the instruction. Table 11-6 defines the error conditions that could result from executing the instruction. The Error and Value outputs are not valid until the Done output turns on.

Table 11-4 Valid Operands for the USS_RPM_x

Inputs/Outputs	Data Type	Operands
XMT_REQ	BOOL	I, Q, M, S, SM, T, C, V, L, Power Flow conditioned by a rising edge detection element
Drive	BYTE	VB, IB, QB, MB, SB, SMB, LB, AC, *VD, *AC, *LD, Constant
Param, Index	WORD	VW, IW, QW, MW, SW, SMW, LW, T, C, AC, AIW, *VD, *AC, *LD, Constant
DB_Ptr	DWORD	&VB
Value	WORD DWORD, REAL	VW, IW, QW, MW, SW, SMW, LW, T, C, AC, AQW, *VD, *AC, *LD VD, ID, QD, MD, SD, SMD, LD, *VD, *AC, *LD
Done	BOOL	I, Q, M, S, SM, T, C, V, L
Error	BYTE	VB, IB, QB, MB, SB, SMB, LB, AC, *VD, *AC, *LD

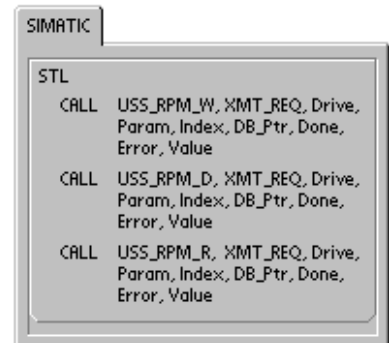
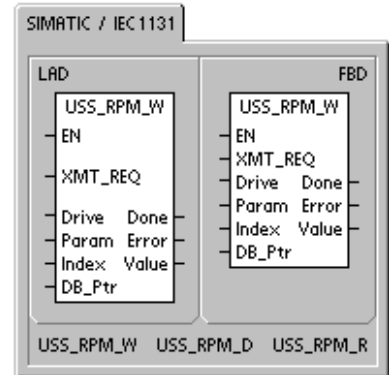

USS_WPM_x Instruction

There are three write instructions for the USS protocol:

- USS_WPM_W instruction writes an unsigned word parameter.
- USS_WPM_D instruction writes an unsigned double word parameter.
- USS_WPM_R instruction writes a floating-point parameter.

Only one read (USS_RPM_x) or write (USS_WPM_x) instruction can be active at a time.

The USS_WPM_x transactions complete when the MicroMaster drive acknowledges receipt of the command, or when an error condition is posted. The logic scan continues to execute while this process awaits a response.

The EN bit must be on to enable transmission of a request, and should remain on until the Done bit is set, signaling completion of the process. For example, a USS_WPM_x request is transmitted to the MicroMaster drive on each scan when XMT_REQ input is on. Therefore, the XMT_REQ input should be pulsed on through an edge detection element which causes one request to be transmitted for each positive transition of the EN input.

The Drive input is the address of the MicroMaster drive to which the USS_WPM_x command is to be sent. Valid addresses of individual drives are 0 to 31.

Param is the parameter number. Index is the index value of the parameter that is to be written. Value is the parameter value to be written to the RAM in the drive. For MicroMaster 3 drives, you can also write this value to the EEPROM of the drive, based on how you have configured P971 (EEPROM Storage Control).

The address of a 16-byte buffer must be supplied to the DB_Ptr input. This buffer is used by the USS_WPM_x instruction to store the results of the command issued to the MicroMaster drive.

When the USS_WPM_x instruction completes, the Done output is turned on and the Error output byte contains the result of executing the instruction. Table 11-6 defines the error conditions that could result from executing the instruction.

When the EEPROM input is turned on, the instruction writes to both the RAM and the EEPROM of the drive. When the the input is turned off, the instruction writes only to the RAM of the drive. Because the MicroMaster 3 drive does not support this function, you must ensure that this input is off in order to use this instruction with a MicroMaster 3 drive.

Table 11-5 Valid Operands for the USS_WPM_x Instructions

Inputs/Outputs	Data Type	Operands
XMT_REQ	BOOL	I, Q, M, S, SM, T, C, V, L, Power Flow conditioned by a rising edge detection element
EEPROM	BOOL	I, Q, M, S, SM, T, C, V, L, Power Flow
Drive	BYTE	VB, IB, QB, MB, SB, SMB, LB, AC, *VD, *AC, *LD, Constant
Param, Index	WORD	VW, IW, QW, MW, SW, SMW, LW, T, C, AC, AIW, *VD, *AC, *LD, Constant
DB_Ptr	DWORD	&VB
Value	WORD DWORD, REAL	VW, IW, QW, MW, SW, SMW, LW, T, C, AC, AQW, *VD, *AC, *LD VD, ID, QD, MD, SD, SMD, LD, *VD, *AC, *LD
Done	BOOL	I, Q, M, S, SM, T, C, V, L
Error	BYTE	VB, IB, QB, MB, SB, SMB, LB, AC, *VD, *AC, *LD

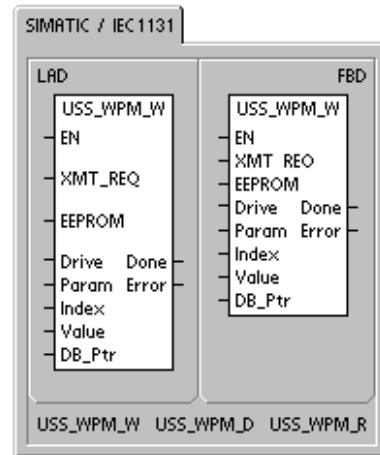

Caution

When you use an USS_WPM_x instruction to update the parameter set stored in drive EEPROM, you must ensure that the maximum number of write cycles (approximately 50,000) to the EEPROM is not exceeded.

Exceeding the maximum number of write cycles will result in corruption of the stored data and subsequent data loss. The number of read cycles is unlimited.

If frequent writes to the drive parameters are required, then you should first set the EEPROM storage control parameter in the drive to zero (for MicroMaster 3 drives) and turn off the EEPROM input for MicroMaster 4 drives.

Example: USS_RPM_x and USS_WPM_x

<p>The image contains two ladder logic diagrams. The first diagram, labeled 'Network 1', shows an instruction box for 'USS_RPM_W'. It has two normally open contacts labeled 'I0.0' in series. The second contact has a 'P' (pulse) symbol. The instruction box has three outputs: 'M0.0', 'M1.0', and 'VW200'. The second diagram, labeled 'Network 2', shows an instruction box for 'USS_WPM_W'. It also has two normally open contacts labeled 'I0.1' in series, with the second having a 'P' symbol. The instruction box has three outputs: 'M0.1', 'M1.1', and 'VB11'.</p>	<p>Network 1 //The two contacts must have the same address.</p> <pre> LD I0.0 = L60.0 LD I0.0 EU = L63.7 LD L60.0 CALL USS_RPM_W, L63.7, 0, 3, 0, &VB100, M0.0, VB10, VW200 </pre> <p>Network 2 //The two contacts must have the same address</p> <pre> LD I0.1 = L60.0 LD I0.1 EU = L63.7 LDN SM0.0 = L63.6 LD L60.0 CALL USS_WPM_W, L63.7, L63.6, 0, 971, 0, 1, &VB120, M0.1, VB11 </pre>
---	---

Sample Programs for the USS Protocol

Example: USS Instructions Sample Program that Correctly Displays in STL

Network 1

Network 2

Network 3

Network 4

Network 1 //Initialize USS Protocol:
 //On the first scan, enable USS protocol
 //for port 0 at 19200 with drive address
 //”0” active.

```
LD SM0.1
CALL USS_INIT, 1, 19200, 16#00000001, Q0.0, VB1
```

Network 2 //Control parameters for Drive 0

```
LD SM0.0
CALL USS_CTRL, I0.0, I0.1, I0.2, I0.3, I0.4, 0, 1, 100.0, M0.0, VB2, VW4, VD6, Q0.1, Q0.2, Q0.3, Q0.4
```

Network 3 //Read a Word parameter from Drive 0.
 //Read parameter 5 index 0.
 //1. Save the state of I0.5 to a temporary
 // location so that this network displays
 // in LAD.
 //2. Save the rising edge pulse of I0.5
 // to a temporary L location so that
 // it can be passed to the subroutine.

```
LD I0.5
= L60.0
LD I0.5
EU
= L63.7
LD L60.0
CALL USS_RPM_W, L63.7, 0, 5, 0, &VB20, M0.1, VB10, VW12
```

Network 4 //Write a Word parameter to Drive 0.
 //Write parameter 2000 index 0.

```
LD I0.6
= L60.0
LD I0.6
EU
= L63.7
LDN SM0.0
= L63.6
LD L60.0
CALL USS_WPM_R, L63.7, L63.6, 0, 2000, 0, 50.0, &VB40, M0.2, VB14
```

Note: This STL code does not compile to LAD or FBD.

USS Execution Error Codes

Table 11-6 Execution Error Codes for the USS Instructions

Error Codes	Description
0	No error
1	Drive did not respond
2	A checksum error in the response from the drive was detected
3	A parity error in the response from the drive was detected
4	An error was caused by interference from the user program
5	An illegal command was attempted
6	An illegal drive address was supplied
7	The communications port was not set up for USS protocol
8	The communications port is busy processing an instruction
9	The drive speed input is out of range
10	The length of the drive response is incorrect
11	The first character of the drive response is incorrect
12	The length character in the drive response is not supported by USS instructions
13	The wrong drive responded
14	The DB_Ptr address supplied is incorrect
15	The parameter number supplied is incorrect
16	An invalid protocol was selected
17	USS is active; change is not allowed
18	An illegal baud rate was specified
19	No communications: the drive is not ACTIVE
20	The parameter or value in the drive response is incorrect or contains an error code
21	A double word value was returned instead of the word value requested
22	A word value was returned instead of the double word value requested

Connecting and Setting Up the MicroMaster Series 3 Drive

Connecting the MicroMaster 3 Drive

You can use the standard PROFIBUS cable and connectors to connect the S7-200 to the MicroMaster Series 3 (MM3) drive. See Figure 11-5 for the proper cable bias and termination of the interconnecting cable.

Caution

Interconnecting equipment with different reference potentials can cause unwanted currents to flow through the interconnecting cable.

These unwanted currents can cause communications errors or damage equipment.

Be sure all equipment that you are about to connect with a communications cable either shares a common circuit reference or is isolated to prevent unwanted current flows.

The shield must be tied to chassis ground or pin 1 on the 9-pin connector. It is recommended that you tie wiring terminal 2–0V on the MicroMaster drive to chassis ground.

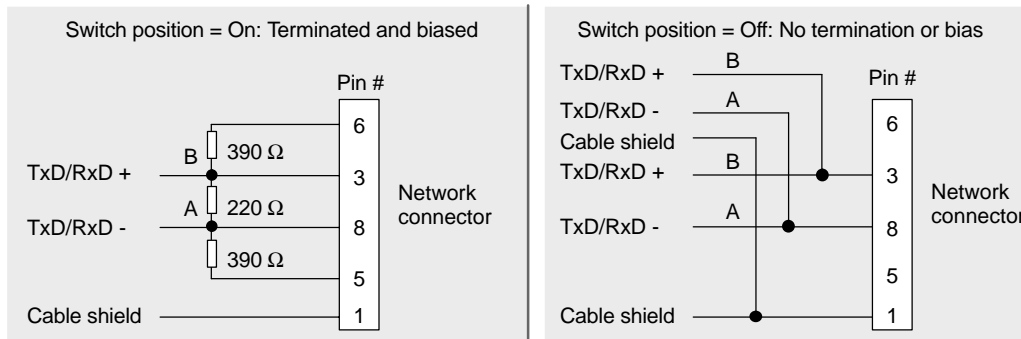
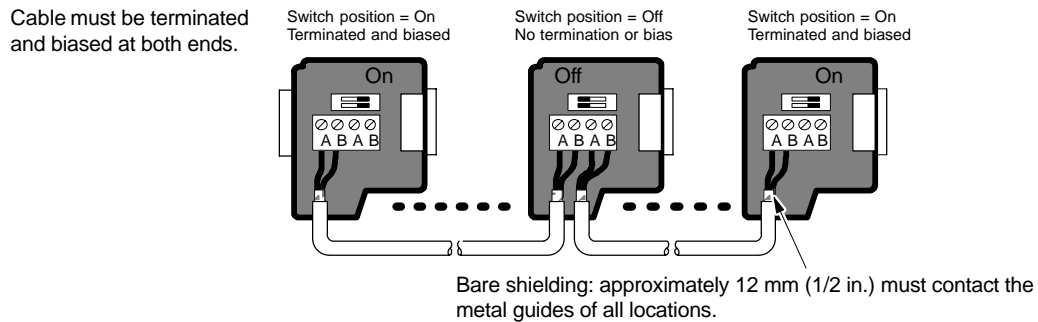

Figure 11-5 Bias and Termination of the Network Cable

Setting Up the MicroMaster 3 Drive

Before you connect a drive to the S7-200, you must ensure that the drive has the following system parameters. Use the keypad on the drive to set the parameters:

1. Reset the drive to factory settings (optional). Press the P key: P000 is displayed. Press the up or down arrow key until the display shows the P944. Press P to enter the parameter.
P944=1
2. Enable the read/write access to all parameters. Press the P key. Press the up or down arrow key until the display shows P009. Press P to enter the parameter.
P009=3
3. Check motor settings for your drive. The settings will vary according to the motor(s) being used. Press the P key. Press the up or down arrow key until the display shows the motor setting for your drive. Press P to enter the parameter.
P081=Nominal frequency of motor (Hz)
P082=Nominal speed of motor (RPM)
P083=Nominal current of motor (A)
P084=Nominal voltage of motor (V)
P085=Nominal power of motor (kW/HP)
4. Set the Local/Remote control mode. Press the P key. Press the up or down arrow key until the display shows P910. Press P to enter the parameter.
P910=1 Remote control mode
5. Set the Baud Rate of the RS-485 serial interface. Press the P key. Press the up or down arrow key until P092 appears. Press P to enter the parameter. Press the up or down arrow key until the display shows the number that corresponds to the baud rate of your RS-485 serial interface. Press P to enter.

P092	3	(1200 baud)
	4	(2400 baud)
	5	(4800 baud)
	6	(9600 baud – default)
	7	(19200 baud)
6. Enter the Slave address. Each drive (a maximum of 31) can be operated over the bus. Press the P key. Press the up or down arrow key until P091 appears. Press P to enter the parameter. Press the up or down arrow key until the display shows the slave address you want. Press P to enter.
P091=0 through 31.
7. Ramp up time (optional). This is the time in seconds that it takes the motor to accelerate to maximum frequency. Press the P key. Press the up or down arrow key until P002 appears. Press P to enter the parameter. Press the up or down arrow key until the display shows the ramp up time you want. Press P to enter.
P002=0–650.00
8. Ramp down time (optional). This is the time in seconds that it takes the motor to decelerate to a complete stop. Press the P key. Press the up or down arrow key until P003 appears. Press P to enter the parameter. Press the up or down arrow key until the display shows the ramp down time you want. Press P to enter.
P003=0–650.00

9. Serial Link Time-out. This is the maximum permissible period between two incoming data telegrams. This feature is used to turn off the inverter in the event of a communications failure.

Timing starts after a valid data telegram has been received. If a further data telegram is not received within the specified time period, the inverter will trip and display fault code F008. Setting the value to zero switches off the control. Use Table 11-1 to calculate the time between the status polls to the drive.

Press the P key. Press the up or down arrow key until P093 appears. Press P to enter the parameter. Press the up or down arrow key until the display shows the serial link time-out you want. Press P to enter.

P093=0–240 (0 is default; time is in seconds)
10. Serial Link Nominal System Setpoint. This value can vary, but will typically correspond to 50 Hz or 60 Hz, which defines the corresponding 100% value for PVs or SPs. Press the P key. Press the up or down arrow key until P094 appears. Press P to enter the parameter. Press the up or down arrow key until the display shows the serial link nominal system setpoint you want. Press P to enter.

P094=0–400.00
11. USS Compatibility (optional). Press the P key. Press the up or down arrow key until P095 appears. Press P to enter the parameter. Press the up or down arrow key until the display shows the number that corresponds to the USS compatibility you want. Press P to enter.

P095 = 0 0.1 Hz resolution (default)
1 0.01 Hz resolution
12. EEPROM storage control (optional). Press the P key. Press the up or down arrow key until P971 appears. Press P to enter the parameter. Press the up or down arrow key until the display shows the number that corresponds to the EEPROM storage control you want. Press P to enter.

P971 = 0 Changes to parameter settings (including P971) are lost when power is removed.
1 (default) Changes to parameter settings are retained during periods when power is removed.
13. Operating display. Press P to exit out of parameter mode.

Connecting and Setting Up the MicroMaster Series 4 Drive

Connecting the MicroMaster 4 Drive

To make the connection to the MicroMaster Series 4 (MM4) drive, insert the ends of the RS-485 cable into the two caged clamp, screwless terminals provided for USS operation. The standard PROFIBUS cable and connectors can be used to connect the S7-200.

Caution

Interconnecting equipment with different reference potentials can cause unwanted currents to flow through the interconnecting cable.

These unwanted currents can cause communications errors or damage equipment.

Be sure all equipment that you are about to connect with a communications cable either shares a common circuit reference or is isolated to prevent unwanted current flows.

The shield must be tied to chassis ground or pin 1 on the 9-pin connector. It is recommended that you tie wiring terminal 2–0V on the MicroMaster drive to chassis ground.

As shown in Figure 11-6, the two wires at the opposite end of the RS-485 cable must be inserted into the MM4 drive terminal blocks. To make the cable connection on a MM4 drive, remove the drive cover(s) to access the terminal blocks. See the MM4 user manual for details about how to remove the covers(s) of your specific drive.

The terminal block connections are labeled numerically. Using a PROFIBUS connector on the S7-200 side, connect the A terminal of the cable to the drive terminal 15 (for an MM420) or terminal 30 (MM440). Connect the B terminal of the cable connector to terminal 14 (MM420) or terminal 29 (MM440).

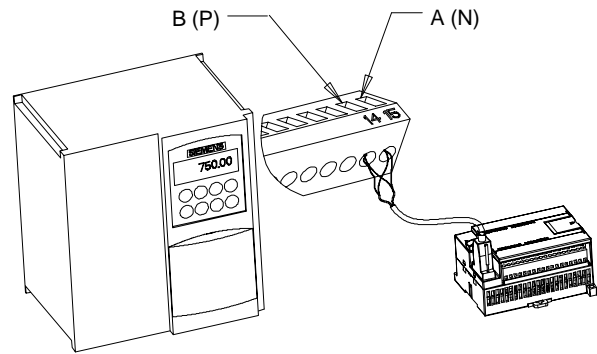

Figure 11-6 Connecting to the MM420 Terminal Block

If the S7-200 is a terminating node in the network, or if the connection is point-to-point, it is necessary to use terminals A1 and B1 (not A2 and B2) of the connector since they allow the termination settings to be set (for example, with DP connector type 6ES7 972-0BA40-0X40).

Caution

Make sure the drive covers are replaced properly before supplying power to the unit.

If the drive is configured as the terminating node in the network, then termination and bias resistors must be also be wired to the appropriate terminal connections. For example, Figure 11-7 shows an example of the connections necessary for termination and bias for the MM4, model 6SE6420 drive.

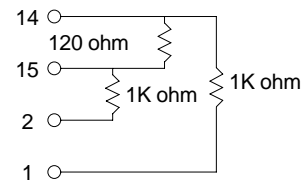

Figure 11-7 Sample Termination and Bias

Setting Up the MM4 Drive

Before you connect a drive to the S7-200, you must ensure that the drive has the following system parameters. Use the keypad on the drive to set the parameters:

1. Reset the drive to factory settings (optional): P0010=30
P0970=1

If you skip this step, ensure that the following parameters are set to these values:

USS PZD length: P2012 Index 0=2
USS PKW length: P2013 Index 0=127

2. Enable the read/write access to all parameters (Expert mode): P0003=3
3. Check motor settings for your drive:
 - P0304=Rated motor voltage (V)
 - P0305=Rated motor current (A)
 - P0307=Rated motor power (W)
 - P0310=Rated motor frequency (Hz)
 - P0311=Rated motor speed (RPM)

The settings will vary according to the motor(s) being used.

In order to set the parameters P304, P305, P307, P310, and P311, you must first set parameter P010 to 1 (quick commissioning mode). When you are finished setting the parameters, set parameter P010 to 0. Parameters P304, P305, P307, P310, and P311 can only be changed in the quick commissioning mode.

4. Set the local/remote control mode: P0700 Index 0=5
5. Set selection of frequency setpoint to USS on COM Link: P1000 Index 0=5
6. Ramp up time (optional): P1120=0 to 650.00
This is the time in seconds that it takes the motor to accelerate to maximum frequency.
7. Ramp down time (optional): P1121=0 to 650.00
This is the time in seconds that it takes the motor to decelerate to a complete stop.
8. Set the serial link reference frequency: P2000=1 to 650 Hz
9. Set the USS normalization: P2009 Index 0=0
10. Set the baud rate of the RS-485 serial interface: P2010 Index 0=
 - 4 (2400 baud)
 - 5 (4800 baud)
 - 6 (9600 baud)
 - 7 (19200 baud)
 - 8 (38400 baud)
 - 9 (57600 baud)
 - 12 (115200 baud)

11. Enter the Slave address: P2011 Index 0=0 to 31

Each drive (a maximum of 31) can be operated over the bus.

12. Set the serial link timeout: P2014 Index 0=0 to 65,535 ms
(0=timeout disabled)

This is the maximum permissible period between two incoming data telegrams. This feature is used to turn off the inverter in the event of a communications failure. Timing starts after a valid data telegram has been received. If a further data telegram is not received within the specified time period, the inverter will trip and display fault code F0070. Setting the value to zero switches off the control. Use Table 11-1 to calculate the time between the status polls to the drive.

13. Transfer the data from RAM to EEPROM:

P0971=1 (Start transfer) Save the changes to the parameter settings to EEPROM

Using the Modbus Protocol Library



STEP 7–Micro/WIN Instruction Libraries makes communicating to Modbus master devices easier by including pre-configured subroutines and interrupt routines that are specifically designed for Modbus communications. With the Modbus Slave Protocol Instructions, you can configure the S7-200 to act as a Modbus RTU slave device and communicate to Modbus master devices.

You find these instructions in the Libraries folder of the STEP 7–Micro/WIN instruction tree. With these new instructions you can make the S7-200 act as a Modbus slave. When you select a Modbus Slave instruction, one or more associated subroutines are automatically added to your project.

In This Chapter

Requirements for Using the Modbus Protocol	330
Initialization and Execution Time for the Modbus Protocol	330
Modbus Addressing	331
Using the Modbus Slave Protocol Instructions	332
Instructions for the Modbus Slave Protocol	333

Requirements for Using the Modbus Protocol

The Modbus Slave Protocol instructions use the following resources from the S7-200:

- Initializing the Modbus Slave Protocol dedicates Port 0 for Modbus Slave Protocol communications.
When Port 0 is being used for Modbus Slave Protocol communications, it cannot be used for any other purpose, including communications with STEP 7–Micro/WIN. The MBUS_INIT instruction controls assignment of Port 0 to Modbus Slave Protocol or PPI.
- The Modbus Slave Protocol instructions affect all of the SM locations associated with Freeport communications on Port 0.
- The Modbus Slave Protocol instructions use 3 subroutines and 2 interrupts.
- The Modbus Slave Protocol instructions require 1857 bytes of program space for the two Modbus Slave instructions and the support routines.
- The variables for the Modbus Slave Protocol instructions require a 779-byte block of V memory. The starting address for this block is assigned by the user and is reserved for Modbus variables.



Tip

To change the operation of Port 0 back to PPI so that you can communicate with STEP 7-Micro/WIN, use another MBUS_INIT instruction to reassign Port 0.

You can also set the mode switch on the S7-200 to STOP mode. This resets the parameters for Port 0.

Initialization and Execution Time for the Modbus Protocol

Modbus communications utilize a CRC (cyclic redundancy check) to insure the integrity of the communications messages. The Modbus Slave Protocol uses a table of precalculated values to decrease the time required to process a message. The initialization of this CRC table requires about 425 milliseconds. This initialization is done inside the MBUS_INIT subroutine and is normally done in the first scan of the user program after entering RUN mode. You are responsible for resetting the watchdog timer and keeping the outputs enabled (if required for expansion modules) if the time required by the MBUS_INIT subroutine and any other user initialization exceeds the 500 millisecond scan watchdog. The output module watchdog timer is reset by writing to the outputs of the module. See the Watchdog Reset Instruction in Chapter 6.

The scan time is extended when the MBUS_SLAVE subroutine services a request. Since most of the time is spent calculating the Modbus CRC, the scan time is extended by about 650 microseconds for every byte in the request and in the response. A maximum request/response (read or write of 120 words) extends the scan time by approximately 165 milliseconds.

Modbus Addressing

Modbus addresses are normally written as 5 or 6 character values containing the data type and the offset. The first one or two characters determine the data type, and the last four characters select the proper value within the data type. The Modbus master device then maps the addresses to the correct functions. The following addresses are supported by the Modbus Slave instructions:

- 000001 to 000128 are discrete outputs mapped to Q0.0 - Q15.7
- 010001 to 010128 are discrete inputs mapped to I0.0 - I15.7
- 030001 to 030032 are analog input registers mapped to AIW0 to AIW62
- 040001 to 04xxxx are holding registers mapped to V memory.

All Modbus addresses are one-based. Table 12-1 shows the mapping of Modbus addresses to the S7-200 addresses.

The Modbus Slave Protocol allows you to limit the amount of inputs, outputs, analog inputs, and holding registers (V memory) accessible to a Modbus master.

The MaxIQ parameter of the MBUS_INIT instruction specifies the maximum number of discrete inputs or outputs (Is or Qs) the Modbus master is allowed to access.

The MaxAI parameter of the MBUS_INIT instruction specifies the maximum number of input registers (AIWs) the Modbus master is allowed to access.

The MaxHold parameter of the MBUS_INIT instruction specifies the maximum number of holding registers (V memory words) the Modbus master is allowed to access.

See the description of the MBUS_INIT instruction for more information on setting up the memory restrictions for the Modbus slave.

Table 12-1 Mapping Modbus Address to the S7-200

Modbus Address	S7-200 Address
000001	Q0.0
000002	Q0.1
000003	Q0.2
...	...
000127	Q15.6
000128	Q15.7
010001	I0.0
010002	I0.1
010003	I0.2
...	...
010127	I15.6
010128	I15.7
030001	AIW0
030002	AIW2
030003	AIW4
...	...
030032	AIW62
040001	HoldStart
040002	HoldStart+2
040003	HoldStart+4
...	...
04xxxx	HoldStart+2 x (xxxx-1)

Configuring the Symbol Table

After you enter an address for the first symbol, the table automatically calculates and assigns the remainder of the symbols in the table.

You should assign a starting V location for the table which occupies 779 bytes. Be sure that the assignment of the Modbus Slave symbols do not overlap with the V memory assigned to the Modbus holding registers with the HoldStart and MaxHold parameters on the MBUS_INIT instruction. If there is any overlap of the memory areas, the MBUS_INIT instruction returns an error.

Using the Modbus Slave Protocol Instructions

To use the Modbus Slave Protocol instructions in your S7-200 program, follow these steps:

1. Insert the MBUS_INIT instruction in your program and execute the MBUS_INIT instruction for one scan only. You can use the MBUS_INIT instruction either to initiate or to change the Modbus communications parameters.
When you insert the MBUS_INIT instruction, several hidden subroutines and interrupt routines are automatically added to your program.
2. Assign a starting address for the 779 bytes of consecutive V memory required for Modbus Slave Protocol instructions.
3. Place only one MBUS_SLAVE instruction in your program. This instruction is called every scan to service any requests that have been received.
4. Connect the communications cable between Port 0 on the S7-200 and the Modbus master devices.

Caution

Interconnecting equipment with different reference potentials can cause unwanted currents to flow through the interconnecting cable. These unwanted currents can cause communications errors or damage equipment.

Ensure that all equipment that is connected with a communications cable either shares a common circuit reference or is isolated to prevent unwanted current flows.

The accumulators (AC0, AC1, AC2, AC3) are utilized by the Modbus slave instructions and appear in the Cross Reference listing. Prior to execution, the values in the accumulators of a Modbus Slave instruction are saved and restored to the accumulators before the Modbus Slave instruction is complete, ensuring that all user data in the accumulators is preserved while executing a Modbus Slave instruction.

The Modbus Slave Protocol instructions support the Modbus RTU protocol. These instructions utilize the Freeport utilities of the S7-200 to support the most common Modbus functions. The following Modbus functions are supported:

Table 12-2 Modbus Slave Protocol Functions Supported

Function	Description
1	Read single/multiple coil (discrete output) status. Function 1 returns the on/off status of any number of output points (Qs).
2	Read single/multiple contact (discrete input) status. Function 2 returns the on/off status of any number of input points (Is).
3	Read single/multiple holding registers. Function 3 returns the contents of V memory. Holding registers are word values under Modbus and allow you to read up to 120 words in one request.
4	Read single/multiple input registers. Function 4 returns Analog Input values.
5	Write single coil (discrete output). Function 5 sets a discrete output point to the specified value. The point is not forced and the program can overwrite the value written by the Modbus request.
6	Write single holding register. Function 6 writes a single holding register value to the V memory of the S7-200.
15	Write multiple coils (discrete outputs). Function 15 writes the multiple discrete output values to the Q image register of the S7-200. The starting output point must begin on a byte boundary (for example, Q0.0 or Q2.0) and the number of outputs written must be a multiple of eight. This is a restriction for the Modbus Slave Protocol instructions. The points are not forced and the program can overwrite the values written by the Modbus request.
16	Write multiple holding registers. Function 16 writes multiple holding registers to the V memory of the S7-200. There can be up to 120 words written in one request.

Instructions for the Modbus Slave Protocol

MBUS_INIT Instruction

The MBUS_INIT instruction is used to enable and initialize, or to disable Modbus communications. Before the MBUS_SLAVE instruction can be used, the MBUS_INIT instruction must be executed without errors. The instruction completes and the Done bit is set immediately, before continuing to the next instruction.

The instruction is executed on each scan when the EN input is on.

The MBUS_INIT instruction should be executed exactly once for each change in communications state. Therefore, the EN input should be pulsed on through an edge detection element, or executed only on the first scan.

The value for the Mode input selects the communications protocol: an input value of 1 assigns port 0 to Modbus protocol and enables the protocol, and an input value of 0 assigns port 0 to PPI and disables Modbus protocol.

The parameter Baud sets the baud rate at 1200, 2400, 4800, 9600, 19200, 38400, 57600, or 115200.

The parameter Addr sets the address at inclusive values between 1 and 247.

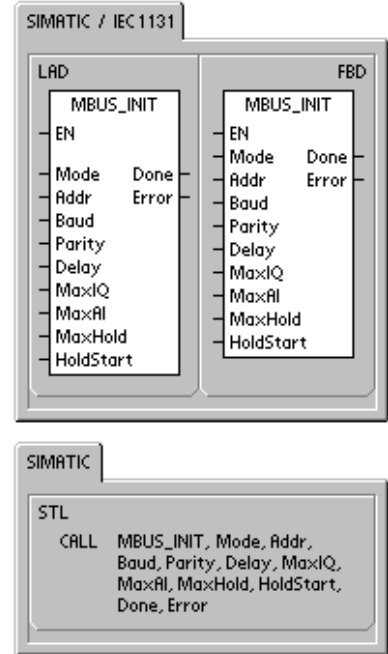

Table 12-3 Parameters for the MBUS_INIT Instruction

Inputs/Outputs	Data Type	Operands
Mode, Addr, Parity	BYTE	VB, IB, QB, MB, SB, SMB, LB, AC, Constant, *VD, *AC, *LD
Baud, HoldStart	DWORD	VD, ID, QD, MD, SD, SMD, LD, AC, Constant, *VD, *AC, *LD
Delay, MaxIQ, MaxAI, MaxHold	WORD	VW, IW, QW, MW, SW, SMW, LW, AC, Constant, *VD, *AC, *LD
Done	BOOL	I, Q, M, S, SM, T, C, V, L
Error	BYTE	VB, IB, QB, MB, SB, SMB, LB, AC, *VD, *AC, *LD

The parameter Parity is set to match the parity of the Modbus master. The accepted values are:

- 0-no parity
- 1-odd parity
- 2-even parity

The parameter Delay extends the standard Modbus end-of-message timeout condition by adding the specified number of milliseconds to the standard Modbus message timeout. The typical value for this parameter should be 0 when operating on a wired network. If you are using modems with error correction, set the delay to a value of 50 to 100 milliseconds. If you are using spread spectrum radios, set the delay to a value of 10 to 100 milliseconds. The Delay value can be 0 to 32767 milliseconds.

The parameter MaxIQ sets the number of I and Q points available to Modbus addresses 00xxxx and 01xxxx at values of 0 to 128. A value of 0 disables all reads and writes to the inputs and outputs. The suggested value for MaxIQ is 128, which allows access to all I and Q points in the S7-200.

The parameter MaxAI sets the number of word input (AI) registers available to Modbus address 03xxx at values of 0 to 32. A value of 0 disables reads of the analog inputs. The suggested value for MaxAI to allow access to all of the S7-200 analog inputs, is as follows:

- 0 for CPU 221
- 16 for CPU 222
- 32 for CPU 224, 226, and 226XM

The parameter MaxHold sets the number of word holding registers in V memory available to Modbus address 04xxx. For example, to allow the master to access 2000 bytes of V memory, set MaxHold to a value of 1000 words (holding registers).

The parameter HoldStart is the address of the start of the holding registers in V memory. This value is generally set to VB0, so the parameter HoldStart is set to &VB0 (address of VB0). Other V memory addresses can be specified as the starting address for the holding registers to allow VB0 to be used elsewhere in the project. The Modbus master has access to MaxHold number of words of V memory starting at HoldStart.

When the MBUS_INIT instruction completes, the Done output is turned on. The Error output byte contains the result of executing the instruction. Table 12-5 defines the error conditions that could result from executing the instruction.

MBUS_SLAVE Instruction

The MBUS_SLAVE instruction is used to service a request from the Modbus master and must be executed every scan to allow it to check for and respond to Modbus requests.

The instruction is executed on each scan when the EN input is on.

The MBUS_SLAVE instruction has no input parameters.

The Done output is on when the MBUS_SLAVE instruction responds to a Modbus request. The Done output is turned off if there was no request serviced.

The Error output contains the result of executing the instruction. This output is only valid if Done is on. If Done is off, the error parameter is not changed. Table 12-5 defines the error conditions that could result from executing the instruction.

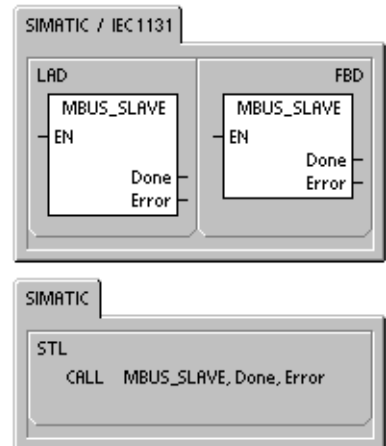
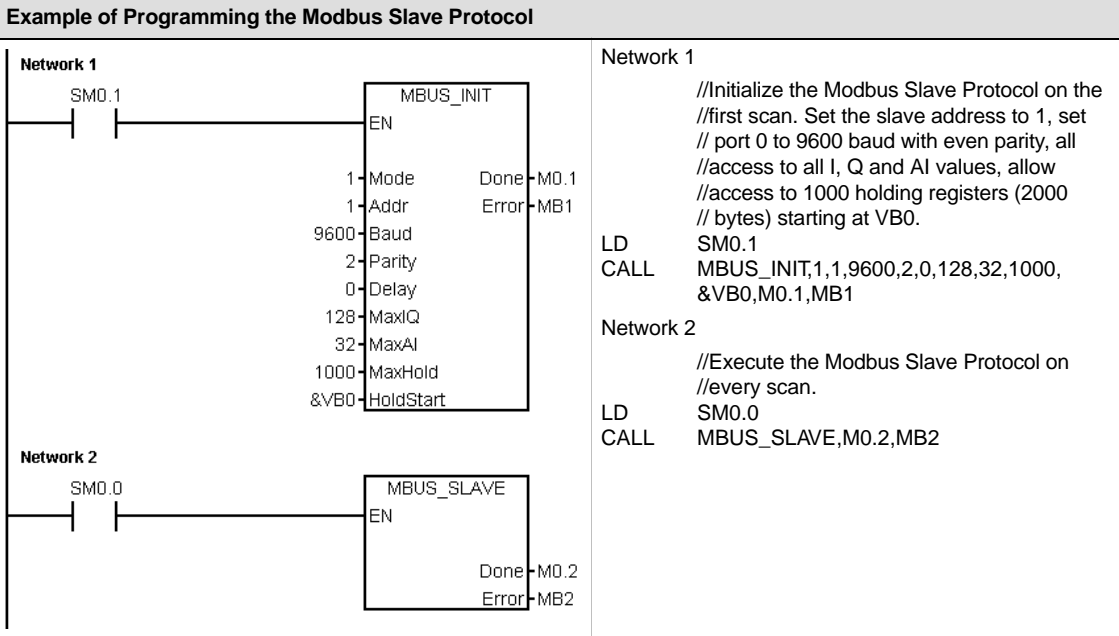

Table 12-4 Parameters for the MBUS_SLAVE Instruction

Parameter	Data Type	Operands
Done	BOOL	I, Q, M, S, SM, T, C, V, L
Error	BYTE	VB, IB, QB, MB, SB, SMB, LB, AC, *VD, *AC, *LD

Table 12-5 Modbus Slave Protocol Execution Error Codes

Error Codes	Description
0	No Error
1	Memory range error
2	Illegal baud rate or parity
3	Illegal slave address
4	Illegal value for Modbus parameter
5	Holding registers overlap Modbus Slave symbols
6	Receive parity error
7	Receive CRC error
8	Illegal function request/function not supported
9	Illegal memory address in request
10	Slave function not enabled



Technical Specifications



In This Chapter

General Technical Specifications	338
CPU Specifications	340
Digital Expansion Modules Specifications	346
Analog Expansion Modules Specifications	351
Thermocouple and RTD Expansion Modules Specifications	361
EM 277 PROFIBUS–DP Module Specifications	373
EM 241 Modem Module Specifications	385
EM 253 Position Module Specifications	387
AS–Interface (CP 243–2) Module Specifications	393
Optional Cartridges	395
I/O Expansion Cable	395
PC/PPI Cable	396
Input Simulators	398

General Technical Specifications

Standards Compliance

The national and international standards listed below were used to determine appropriate performance specifications and testing for the S7-200 family of products. Table A-1 defines the specific adherence to these standards.

- European Community (CE) Low Voltage Directive 73/23/EEC
EN 61131-2: Programmable controllers – Equipment requirements
- European Community (CE) EMC Directive 89/336/EEC
Electromagnetic emission standard
EN 50081-1: residential, commercial, and light industry
EN 50081-2: industrial environment
Electromagnetic immunity standards
EN 61000-6-2: industrial environment
- Underwriters Laboratories, Inc.: UL 508 Listed (Industrial Control Equipment)
Registration number E75310
- Canadian Standards Association: CSA C22.2 Number 142 Certified (Process Control Equipment)
- Factory Mutual Research: FM Class I, Division 2, Groups A, B, C, & D Hazardous Locations, T4A and Class I, Zone 2, IIC, T4.

Maritime Approvals

The following table identifies the maritime agency and the associated certificate number at the time this manual was printed.

For the latest product approvals, contact your local Siemens distributor or sales office.

Agency	Certificate Number
Lloyds Register of Shipping (LRS)	99 / 20018(E1)
American Bureau of Shipping (ABS)	01-HG20020-PDA
Germanischer Lloyd (GL)	12 045 – 98 HH
Det Norske Veritas (DNV)	A-8071
Bureau Veritas (BV)	09051 / A2 BV
Nippon Kaiji Kyokai (NK)	A-534

Technical Specifications

All S7-200 CPUs and expansion modules conform to the technical specifications listed in Table A-1.

Notice

When a mechanical contact turns on output power to the S7-200 CPU, or any digital expansion module, it sends a “1” signal to the digital outputs for approximately 50 microseconds. You must plan for this, especially if you are using devices which respond to short duration pulses.

Relay Electrical Service Life

The typical performance data supplied by relay vendors is shown in Figure A-1. Actual performance may vary depending upon your specific application.

An external protection circuit that is adapted to the load will enhance the service life of the contacts.

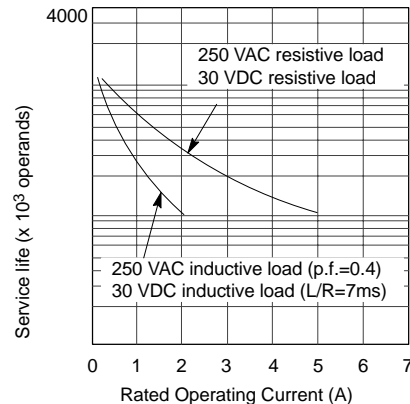

Figure A-1 Relay Electrical Service Life

Table A-1 Technical Specifications

Environmental Conditions — Transport and Storage	
IEC 68–2–2, Test Bb, Dry heat and IEC 68–2–1, Test Ab, Cold	–40° C to +70° C
IEC 68–2–30, Test Db, Damp heat	25° C to 55° C, 95% humidity
IEC 68–2–31, Toppling	100 mm, 4 drops, unpacked
IEC 68–2–32, Free fall	1 m, 5 times, packed for shipment
Environmental Conditions — Operating	
Ambient Temperature Range (Inlet Air 25 mm below unit)	0° C to 55° C horizontal mounting, 0° C to 45° C vertical mounting 95% non-condensing humidity
IEC 68–2–14, Test Nb	5° C to 55° C, 3° C/minute
IEC 68–2–27 Mechanical shock	15 G, 11 ms pulse, 6 shocks in each of 3 axis
IEC 68–2–6 Sinusoidal vibration	Panel mount: 0.30 mm from 10 to 57 Hz; 2 G from 57 to 150 Hz DIN rail mount: 0.15 mm from 10 to 57 Hz; 1 G from 57 to 150 Hz 10 sweeps each axis, 1 octave/minute
EN 60529, IP20 Mechanical protection	Protects against finger contact with high voltage as tested by standard probes. External protection is required for dust, dirt, water, and foreign objects of less than 12.5 mm in diameter.
Electromagnetic Compatibility — Immunity per EN61000–6–2 ¹	
EN 61000–4–2 Electrostatic discharge	8 kV air discharge to all surfaces and communications port, 4kV contact discharge to exposed conductive surfaces
EN 61000–4–3 Radiated electromagnetic field	80 MHz to 1 GHz 10 V/m, 80% modulation with 1 kHz signal
EN 61000–4–4 Fast transient bursts	2 kV, 5 kHz with coupling network to AC and DC system power 2 kV, 5 kHz with coupling clamp to digital I/O 1 kV, 5 kHz with coupling clamp to communications
EN 61000–4–5 Surge immunity	Power supply: 2 kV asymmetrical, 1 kV symmetrical I/O 1 kV symmetrical (24 VDC circuits require external surge protection)
EN 61000–4–6 Conducted disturbances	0.15 to 80 MHz 10 V RMS 80% amplitude modulation at 1kHz
EN 61000–4–11 Voltage dips, short interruptions and voltage variations	>95% reduction for 8.3 ms, 83 ms, 833 ms, and 4167 ms
VDE 0160 Non-periodic overvoltage	At 85 VAC line, 90° phase angle, apply 390 V peak, 1.3 ms pulse At 180 VAC line, 90° phase angle, apply 750 V peak, 1.3 ms pulse
Electromagnetic Compatibility — Conducted and Radiated Emissions per EN50081 –1 ² and –2	
EN 55011, Class A, Group 1, conducted ¹ 0.15 MHz to 0.5 MHz 0.5 MHz to 5 MHz 5 MHz to 30 MHz	< 79 dB (µV) Quasi-peak; < 66 dB (µV) Average < 73 dB (µV) Quasi-peak; < 60 dB (µV) Average < 73 dB (µV) Quasi-peak; < 60 dB (µV) Average
EN 55011, Class A, Group 1, radiated ¹ 30 MHz to 230 MHz 230 MHz to 1 GHz	30 dB (µV/m) Quasi-peak; measured at 30 m 37 dB (µV/m) Quasi-peak; measured at 30 m
EN 55011, Class B, Group 1, conducted ² 0.15 to 0.5 MHz 0.5 MHz to 5 MHz 5 MHz to 30 MHz	< 66 dB (µV) Quasi-peak decreasing with log frequency to 56 dB (µV); < 56 dB (µV) Average decreasing with log frequency to 46 dB (µV) < 56 dB (µV) Quasi-peak; < 46 dB (µV) Average < 60 dB (µV) Quasi-peak; < 50 dB (µV) Average
EN 55011, Class B, Group 1, radiated ² 30 MHz to 230 kHz 230 MHz to 1 GHz	30 dB (µV/m) Quasi-peak; measured at 10 m 37 dB (µV/m) Quasi-peak; measured at 10 m
High Potential Isolation Test	
24 V/5 V nominal circuits	500 VAC (optical isolation boundaries)
115/230 V circuits to ground	1,500 VAC
115/230 V circuits to 115/230 V circuits	1,500 VAC
230 V circuits to 24 V/5 V circuits	1,500 VAC
115 V circuits to 24 V/5 V circuits	1,500 VAC

¹ Unit must be mounted on a grounded metallic frame with the S7-200 ground connection made directly to the mounting metal. Cables are routed along metallic supports.
² Unit must be mounted in a grounded metal enclosure. AC input power line must be equipped with a EPCOS B84115–E–A30 filter or equivalent, 25 cm max. wire length from filters to the S7-200. The 24 VDC supply and sensor supply wiring must be shielded.

A

CPU Specifications

Table A-2 CPU Order Numbers

Order Number	CPU Model	CPU Power Supply (Nominal)	CPU Inputs	CPU Outputs	Removable Connector
6ES7 211-0AA22-0XB0	CPU 221	24 VDC	6 x 24 VDC	4 x 24 VDC	No
6ES7 211-0BA22-0XB0	CPU 221	120 to 240 VAC	6 x 24 VDC	4 x Relay	No
6ES7 212-1AB22-0XB0	CPU 222	24 VDC	8 x 24 VDC	6 x 24 VDC	No
6ES7 212-1BB22-0XB0	CPU 222	120 to 240 VAC	8 x 24 VDC	6 x Relay	No
6ES7 214-1AD22-0XB0	CPU 224	24 VDC	14 x 24 VDC	10 x 24 VDC	Yes
6ES7 214-1BD22-0XB0	CPU 224	120 to 240 VAC	14 x 24 VDC	10 x Relay	Yes
6ES7 216-2AD22-0XB0	CPU 226	24 VDC	24 x 24 VDC	16 x 24 VDC	Yes
6ES7 216-2BD22-0XB0	CPU 226	120 to 240 VAC	24 x 24 VDC	16 x Relay	Yes
6ES7 216-2AF22-0XB0	CPU 226XM	24 VDC	24 x 24 VDC	16 x 24 VDC	Yes
6ES7 216-2BF22-0XB0	CPU 226XM	120 to 240 VAC	24 x 24 VDC	16 x Relay	Yes

Table A-3 CPU General Specifications

Order Number	Module Name and Description	Dimensions (mm) (W x H x D)	Weight	Dissipation	VDC Available	
					+5 VDC	+24 VDC
6ES7 211-0AA22-0XB0	CPU 221 DC/DC/DC 6 Inputs/ 4 Outputs	90 x 80 x 62	270 g	3 W	0 mA	180 mA
6ES7 211-0BA22-0XB0	CPU 221 AC/DC/Relay 6 Inputs/ 4 Relays	90 x 80 x 62	310 g	6 W	0 mA	180 mA
6ES7 212-1AB22-0XB0	CPU 222 DC/DC/DC 8 Inputs/ 6 Outputs	90 x 80 x 62	270 g	5 W	340 mA	180 mA
6ES7 212-1BB22-0XB0	CPU 222 AC/DC/Relay 8 Inputs/ 6 Relays	90 x 80 x 62	310 g	7 W	340 mA	180 mA
6ES7 214-1AD22-0XB0	CPU 224 DC/DC/DC 14 Inputs/ 10 Outputs	120.5 x 80 x 62	360 g	7 W	660 mA	280 mA
6ES7 214-1BD22-0XB0	CPU 224 AC/DC/Relay 14 Inputs/ 10 Relays	120.5 x 80 x 62	410 g	10 W	660 mA	280 mA
6ES7 216-2AD22-0XB0	CPU 226 DC/DC/DC 24 Inputs/16 Outputs	196 x 80 x 62	550 g	11 W	1000 mA	400 mA
6ES7 216-2BD22-0XB0	CPU 226 AC/DC/Relay 24 Inputs/16 Relays	196 x 80 x 62	660 g	17 W	1000 mA	400 mA
6ES7 216-2AF22-0XB0	CPU 226XM DC/DC/DC 24 Inputs/16 Outputs	196 x 80 x 62	550 g	11 W	1000 mA	400 mA
6ES7 216-2BF22-0XB0	CPU 226XM AC/DC/Relay 24 Inputs/16 Relays	196 x 80 x 62	660 g	17 W	1000 mA	400 mA

Table A-4 CPU Specifications

	CPU 221	CPU 222	CPU 224	CPU 226	CPU 226XM
Memory					
User program size (EEPROM)	2048 words		4096 words	4096 words	8192 words
User data (EEPROM)	1024 words (stored permanently)		2560 words (stored permanently)	2560 words (stored permanently)	5120 words (stored permanently)
Backup (super cap) (optional battery)	50 hours typical (8 hours min. at 40°C) 200 days typical		190 hours typical (120 hours min. at 40°C) 200 days typical		
I/O					
Built-in digital inputs/outputs	6 inputs/4 outputs	8 inputs/6 outputs	14 inputs/10 outputs	24 inputs/16 outputs	
Digital I/O image size	256 (128 In/128 Out)				
Analog I/O image size	None	32 (16 In/16 Out)	64 (32 In/32 Out)		
Max. expansion modules allowed	None	2 modules	7 modules		
Max. intelligent modules allowed	None	2 modules	7 modules		
Pulse Catch inputs	6	8	14		
High-Speed Counters	4 counters total 4 at 30 kHz 2 at 20 kHz		6 counters total 6 at 30 kHz 4 at 20 kHz		
Pulse outputs	2 at 20 kHz (DC outputs only)				

A

	CPU 221	CPU 222	CPU 224	CPU 226	CPU 226XM
General					
Timers	256 total timers; 4 timers (1 ms); 16 timers (10 ms); 236 timers (100 ms)				
Counters	256 (backed by super capacitor or battery)				
Internal memory bits Stored on power down	256 (backed by super capacitor or battery) 112 (stored to EEPROM)				
Timed interrupts	2 with 1 ms resolution				
Edge interrupts	4 up and/or 4 down				
Analog adjustment	1 with 8 bit resolution		2 with 8 bit resolution		
Boolean execution speed	0.37 μs per instruction				
Time-of-Day clock	Optional cartridge		Built-in		
Cartridge options	Memory, battery and Time-of-Day Clock		Memory and battery		
Communications Built-in					
Ports	1 RS-485 port			2 RS-485 ports	
PPI, DP/T baud rates	9.6, 19.2, 187.5 kbaud				
Freeport baud rates	1.2 kbaud to 115.2 kbaud				
Max. cable length per segment	With isolated repeater: 1000 m up to 187.5 kbaud, 1200 m up to 38.4 kbaud Without isolated repeater: 50 m				
Max. number of stations	32 per segment, 126 per network				
Max. number of masters	32				
Peer to Peer (PPI Master Mode)	Yes (NETR/NETW)				
MPI connections	4 total, 2 reserved (1 for a PG and 1 for an OP)				

Table A-5 CPU Power Specifications

	DC		AC	
Input Power				
Input voltage	20.4 to 28.8 VDC		85 to 264 VAC (47 to 63 Hz)	
Input current	CPU only at 24 VDC	Max. load at 24 VDC	CPU only	Max. load
CPU 221	80 mA	450 mA	30/15 mA at 120/240 VAC	120/60 mA at 120/240 VAC
CPU 222	85 mA	500 mA	40/20 mA at 120/240 VAC	140/70 mA at 120/240 VAC
CPU 224	110 mA	700 mA	60/30 mA at 120/240 VAC	200/100 mA at 120/240VAC
CPU 226/CPU 226XM	150 mA	1050 mA	80/40 mA at 120/240 VAC	320/160 mA at 120/240VAC
Inrush current	10 A at 28.8 VDC		20 A at 264 VAC	
Isolation (field to logic)	Not isolated		1500 VAC	
Hold up time (loss of power)	10 ms at 24 VDC		20/80 ms at 120/240 VAC	
Fuse (non-replaceable)	3 A, 250 V Slow Blow		2 A, 250 V Slow Blow	
24 VDC Sensor Power				
Sensor voltage	L+ minus 5 V		20.4 to 28.8 VDC	
Current limit	1.5 A peak, thermal limit non-destructive			
Ripple noise	Derived from input power		Less than 1 V peak-to-peak	
Isolation (sensor to logic)	Not isolated			

Table A-6 CPU Input Specifications

General	24 VDC Input
Type	Sink/Source (IEC Type 1 Sink)
Rated voltage	24 VDC at 4 mA typical
Max. continuous permissible voltage	30 VDC
Surge voltage	35 VDC for 0.5 s
Logic 1 (min.)	15 VDC at 2.5 mA
Logic 0 (max.)	5 VDC at 1 mA
Input delay	Selectable (0.2 to 12.8 ms) CPU 226, CPU 226XM: points I1.6 to I2.7 have fixed delay (4.5 ms)

A

Table A-6 CPU Input Specifications, continued

General	24 VDC Input	
Connection of 2 wire proximity sensor (Bero) Permissible leakage current (max.)	1 mA	
Isolation (field to logic) Optical (galvanic) Isolation groups	Yes 500 VAC for 1 minute See wiring diagram	
High speed input rate (max.) Logic1 = 15 to 30 VDC Logic1 = 15 to 26 VDC	Single phase 20 kHz 30 kHz	Two phase 10 kHz 20 kHz
Inputs on simultaneously	All at 55° C	
Cable length (max.) Shielded Unshielded	500 m normal inputs, 50 m HSC inputs 300 m normal inputs	

Table A-7 CPU Output Specifications

General	24 VDC Output	Relay Output
Type	Solid State-MOSFET ¹	Dry contact
Rated voltage	24 VDC	24 VDC or 250 VAC
Voltage range	20.4 to 28.8 VDC	5 to 30 VDC or 5 to 250 VAC
Surge current (max.)	8 A for 100 ms	7 A contacts closed
Logic 1 (min.)	20 VDC at maximum current	–
Logic 0 (max.)	0.1 VDC with 10 K Ω Load	–
Rated current per point (max.)	0.75 A	2.0 A
Rated current per common (max.)	6 A	10 A
Leakage current (max.)	10 μ A	–
Lamp load (max.)	5 W	30 W DC; 200 W AC
Inductive clamp voltage	L+ minus 48 VDC, 1 W dissipation	–
On State resistance (contact)	0.3 Ω max.	0.2 Ω (maximum when new)
Isolation Optical (galvanic, field to logic) Logic to contact Contact to contact Resistance (logic to contact) Isolation groups	500 VAC for 1 minute – – – See wiring diagram	– 1500 VAC for 1 minute 750 VAC for 1 minute 100 M Ω See wiring diagram
Delay Off to On/On to Off (max.) Switching (max.)	2/10 μ s (Q0.0 and Q0.1) 15/100 μ s (all other) –	– 10 ms
Pulse frequency (max.) Q0.0 and Q0.1	20 kHz	1 Hz
Lifetime mechanical cycles	–	10,000,000 (no load)
Lifetime contacts	–	100,000 (rated load)
Outputs on simultaneously	All at 55° C	All at 55° C
Connecting two outputs in parallel	Yes	No
Cable length (max.) Shielded Unshielded	500 m 150 m	500 m 150 m

¹ When a mechanical contact turns on output power to the S7-200 CPU, or any digital expansion module, it sends a "1" signal to the digital outputs for approximately 50 microseconds. You must plan for this, especially if you are using devices which respond to short duration pulses.

Wiring Diagrams

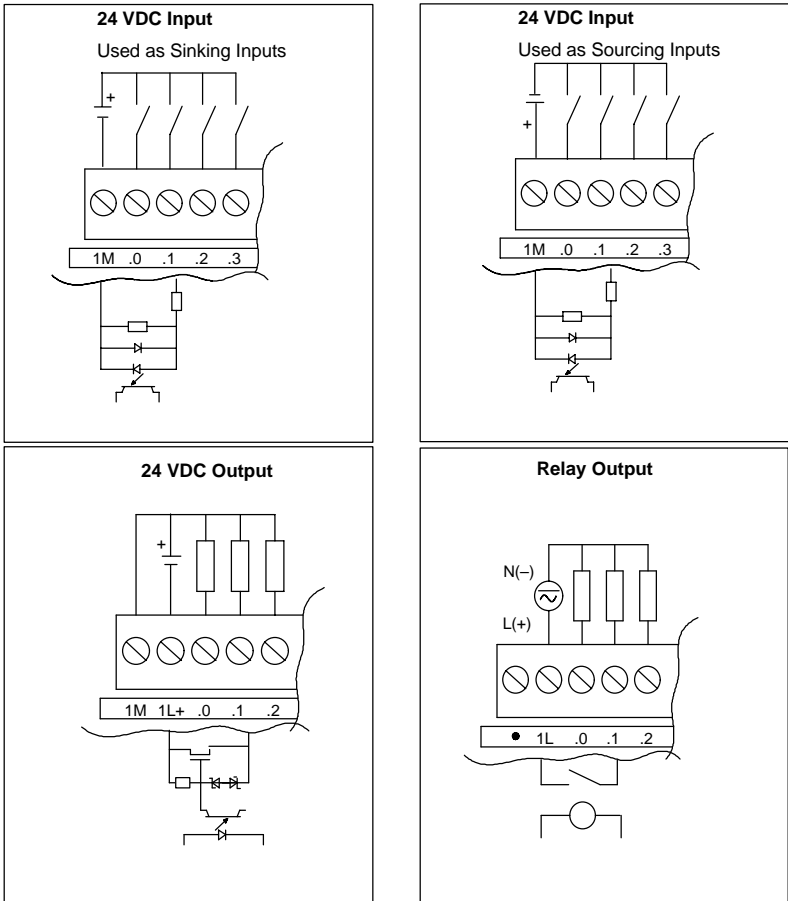

Figure A-2 CPU Inputs and Outputs

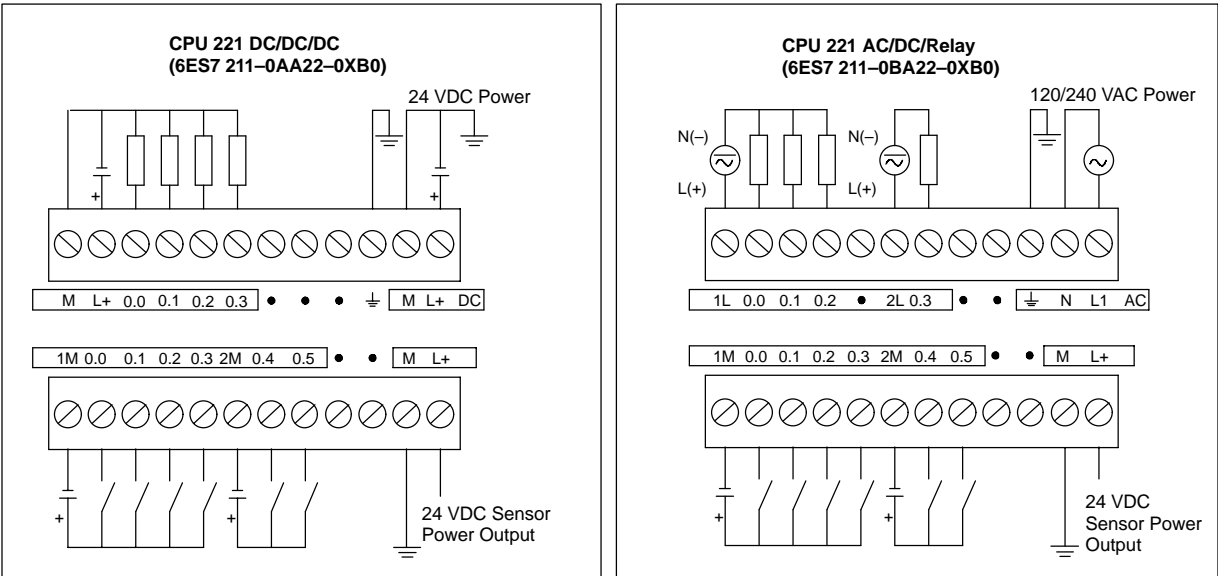

Figure A-3 CPU 221 Wiring Diagrams

A

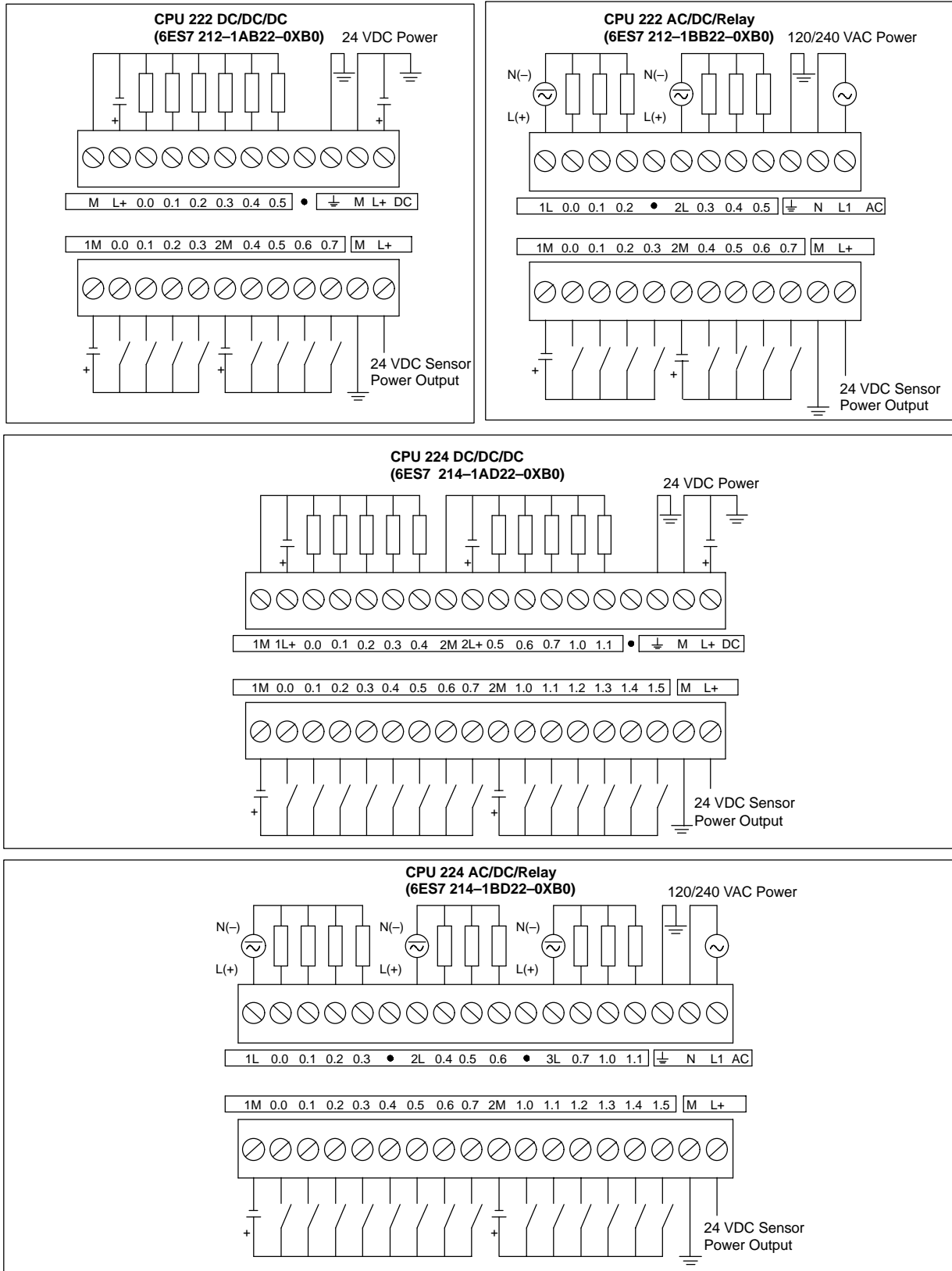

Figure A-4 CPU 222 and CPU 224 Wiring Diagrams

A

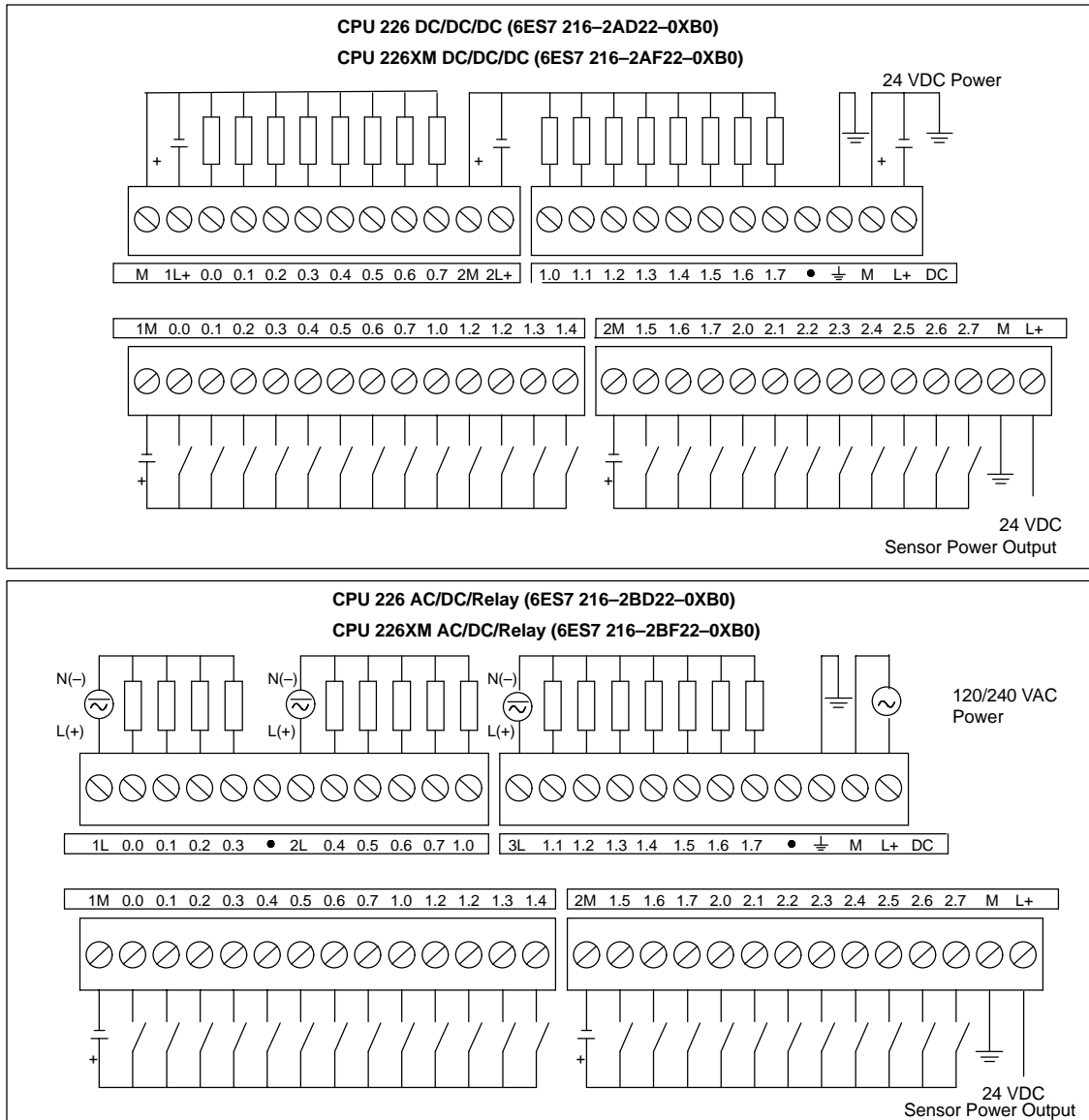

Figure A-5 CPU 226 and CPU 226XM Wiring Diagrams

A

Table A-8 Pin Assignments for the S7-200 Communications Port

Connector	Pin Number	PROFIBUS Signal	Port 0/Port 1
	1	Shield	Chassis ground
	2	24 V Return	Logic common
	3	RS-485 Signal B	RS-485 Signal B
	4	Request-to-Send	RTS (TTL)
	5	5 V Return	Logic common
	6	+5 V	+5 V, 100 Ω series resistor
	7	+24 V	+24 V
	8	RS-485 Signal A	RS-485 Signal A
	9	Not applicable	10-bit protocol select (input)
	Connector shell	Shield	Chassis ground

Digital Expansion Modules Specifications

Table A-9 Digital Expansion Modules Order Numbers

Order Number	Expansion Model	EM Inputs	EM Outputs	Removable Connector
6ES7 221-1BF22-0XA0	EM 221 Digital Input 8 x 24 VDC	8 x 24 VDC	–	Yes
6ES7 221-1EF22-0XA0	EM 221 Digital Input 8 x AC 120/230 V	8 x AC 120/230V	–	Yes
6ES7 222-1BF22-0XA0	EM 222 Digital Output 8 x 24 VDC	–	8 x 24 VDC	Yes
6ES7 222-1HF22-0XA0	EM 222 Digital Output 8 x Relays	–	8 x Relay	Yes
6ES7 222-1EF22-0XA0	EM 222 Digital Output 8 x AC 120/230 V	–	8 x AC 120/230 V	Yes
6ES7 223-1BF22-0XA0	EM 223 24 VDC Digital Combination 4 Inputs/4 Outputs	4 x 24 VDC	4 x 24 VDC	Yes
6ES7 223-1HF22-0XA0	EM 223 24 VDC Digital Combination 4 Inputs/4 Relay Outputs	4 x 24 VDC	4 x Relay	Yes
6ES7 223-1BH22-0XA0	EM 223 24 VDC Digital Combination 8 Inputs/8 Outputs	8 x 24 VDC	8 x 24 VDC	Yes
6ES7 223-1PH22-0XA0	EM 223 24 VDC Digital Combination 8 Inputs/8 Relay Outputs	8 x 24 VDC	8 x Relay	Yes
6ES7 223-1BL22-0XA0	EM 223 24 VDC Digital Combination 16 Inputs/16 Outputs	16 x 24 VDC	16 x 24 VDC	Yes
6ES7 223-1PL22-0XA0	EM 223 24 VDC Digital Combination 16 Inputs/16 Relay Outputs	16 x 24 VDC	16 x Relay	Yes

Table A-10 Digital Expansion Modules General Specifications

Order Number	Module Name and Description	Dimensions (mm) (W x H x D)	Weight	Dissipation	VDC Requirements	
					+5 VDC	+24 VDC
6ES7 221-1BF22-0XA0	EM 221 DI 8 x 24 VDC	46 x 80 x 62	150 g	2 W	30 mA	–
6ES7 221-1EF22-0XA0	EM 221 DI 8 x AC 120/230 V	71.2 x 80 x 62	160 g	3 W	30 mA	–
6ES7 222-1BF22-0XA0	EM 222 DO 8 x 24 VDC	46 x 80 x 62	150 g	2 W	50 mA	–
6ES7 222-1HF22-0XA0	EM 222 DO 8 x Relays	46 x 80 x 62	170 g	2 W	40 mA	ON: 9 mA/output, 20.4 to 28.8 VDC
6ES7 222-1EF22-0XA0	EM 222 DO 8 x AC 120/230 V	71.2 x 80 x 62	165 g	4 W	110 mA	–
6ES7 223-1BF22-0XA0	EM 223 24 VDC 4 In/4 Out	46 x 80 x 62	160 g	2 W	40 mA	–
6ES7 223-1HF22-0XA0	EM 223 24 VDC 4 In/4 Relays	46 x 80 x 62	170 g	2 W	40 mA	ON: 9 mA/output, 20.4 to 28.8 VDC
6ES7 223-1BH22-0XA0	EM 223 24 VDC 8 In/8 Out	71.2 x 80 x 62	200 g	3 W	80 mA	–
6ES7 223-1PH22-0XA0	EM 223 24 VDC 8 In/8 Relays	71.2 x 80 x 62	300 g	3 W	80 mA	ON: 9 mA/output, 20.4 to 28.8 VDC
6ES7 223-1BL22-0XA0	EM 223 24 VDC 16 In/16 Out	137.3 x 80 x 62	360 g	6 W	160 mA	–
6ES7 223-1PL22-0XA0	EM 223 24 VDC 16 In/16 Relays	137.3 x 80 x 62	400 g	6 W	150 mA	ON: 9 mA/output, 20.4 to 28.8 VDC

A

Table A-11 Digital Expansion Modules Input Specifications

General	24 VDC Input	120/230 VAC Input (47 to 63 HZ)
Type	Sink/Source (IEC Type 1 sink)	IEC Type I
Rated voltage	24 VDC at 4 mA	120 VAC at 6 mA or 230 VAC at 9 mA nominal
Maximum continuous permissible voltage	30 VDC	264 VAC
Surge voltage (max.)	35 VDC for 0.5 s	–
Logic 1 (min.)	15 VDC at 2.5 mA	79 VAC at 2.5 mA
Logic 0 (max.)	5 VDC at 1 mA	20 VAC or 1 mA AC
Input delay (max.)	4.5 ms	15 ms
Connection of 2 wire proximity sensor (Bero)		
Permissible leakage current (max.)	1 mA	1 mA AC
Isolation		
Optical (galvanic, field to logic)	500 VAC for 1 minute	1500 VAC for 1 minute
Isolation groups	See wiring diagram	1 point

Table A-11 Digital Expansion Modules Input Specifications, continued

General	24 VDC Input	120/230 VAC Input (47 to 63 HZ)
Inputs on simultaneously	All at 55° C	All at 55° C
Cable length (max.) Shielded Unshielded	500 m 300 m	500 m 300 m

Table A-12 Digital Expansion Modules Output Specifications

General	24 VDC Output	Relay Output	120/230 VAC Output
Type	Solid state-MOSFET ¹	Dry contact	Triac, zero-cross turn-on ²
Rated voltage	24 VDC	24 VDC or 250 VAC	120/230 VAC
Voltage range	20.4 to 28.8 VDC	5 to 30 VDC or 5 to 250 VAC	40 to 264 VAC (47 to 63 Hz)
24 VDC coil power voltage range	–	20.4 to 28.8 VDC	–
Surge current (max.)	8 A for 100 ms	7 A with contacts closed	5 A rms for 2 AC cycles
Logic 1 (min.)	20 VDC	–	L1 (–0.9 V rms)
Logic 0 (max.)	0.1 VDC	–	–
Rated current per point (max.)	0.75 A	2.00 A	0.5 A AC ³
Rated current per common (max.)	6 A	8 A	0.5 A AC
Leakage current (max.)	10 µA	–	1.1 mA rms at 132 VAC and 1.8 mA rhesus at 264 VAC
Lamp load (max.)	5 W	30 W DC/200 W AC	60 W
Inductive clamp voltage	L+ minus 48 V	–	–
On state resistance (contact)	0.3 Ω (maximum)	0.2 Ω maximum when new	410 Ω maximum when load current is less than 0.05 A
Isolation			
Optical (galvanic, field to logic)	500 VAC for 1 minute	–	1500 VAC for 1 minute
Coil to logic	–	None	–
Coil to contact	–	1500 VAC for 1 minute	–
Contact to contact	–	750 VAC for 1 minute	–
Resistance (coil to contact)	–	100 M.Ω min. when new	–
Isolation groups	See wiring diagram	4 points	1 point
Delay Off to On/On to Off (max.)	50 µs max./200 µs	–	0.2 ms + 1/2 AC cycle
Switching (max.)	–	10 ms	–
Switching frequency (max.)	–	1 Hz	10 Hz
Lifetime mechanical cycles	–	10,000,000 (no load)	–
Lifetime contacts	–	100,000 (rated load)	–
Output on simultaneously	All at 55° C	All at 55° C	All at 55° C
Connecting two outputs in parallel	Yes	No	No
Cable length (max.) Shielded Unshielded	500 m 150 m	500 m 150 m	500 m 150 m

- 1 When a mechanical contact turns on output power to the S7-200 CPU, or any digital expansion module, it sends a “1” signal to the digital outputs for approximately 50 microseconds. You must plan for this, especially if you are using devices which respond to short duration pulses.
- 2 When a mechanical contact turns on output power to the AC expansion module, it sends a “1” signal to the AC outputs for approximately 1/2 AC cycle. You must plan for this.
- 3 Load current must be full wave AC and must not be half-wave because of the zero-cross circuitry. Minimum load current is 0.05 A AC. With a load current between 5 mA and 50 mA AC, the current can be controlled, but there is an additional voltage drop due to series resistance of 410 Ohms.



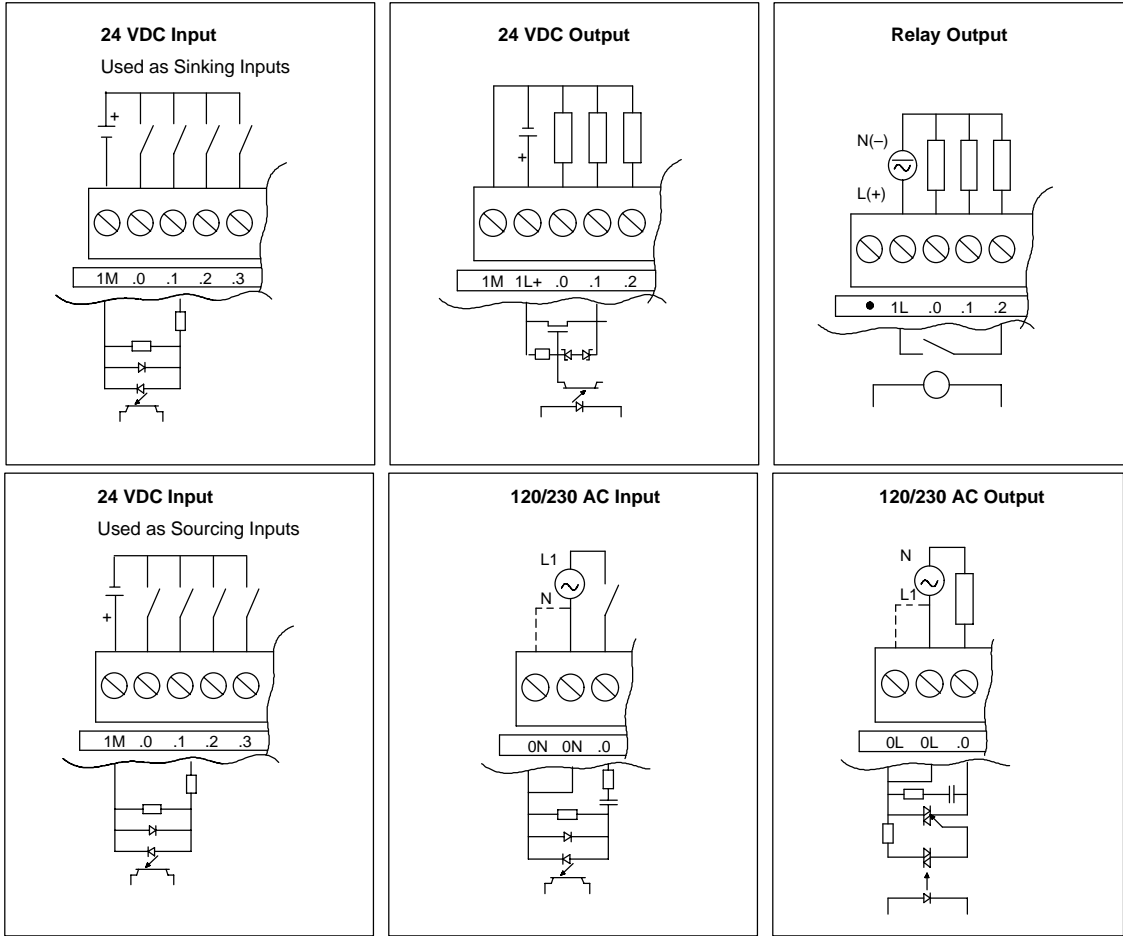

Figure A-6 S7-200 Digital Expansion Modules Inputs and Outputs

Wiring Diagrams

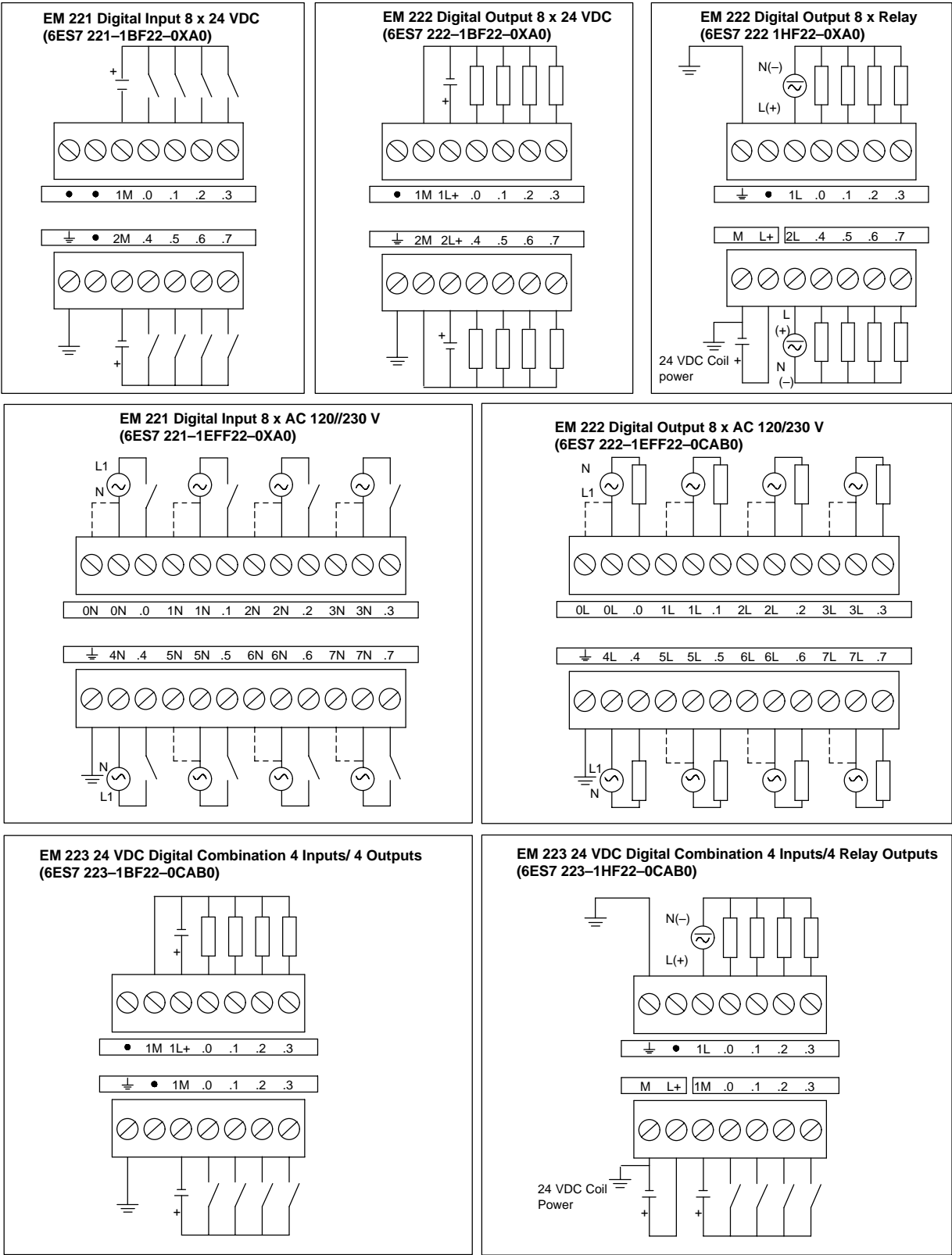

Figure A-7 Wiring Diagrams for EM 221, EM 222, and EM 223 Expansion Modules

A

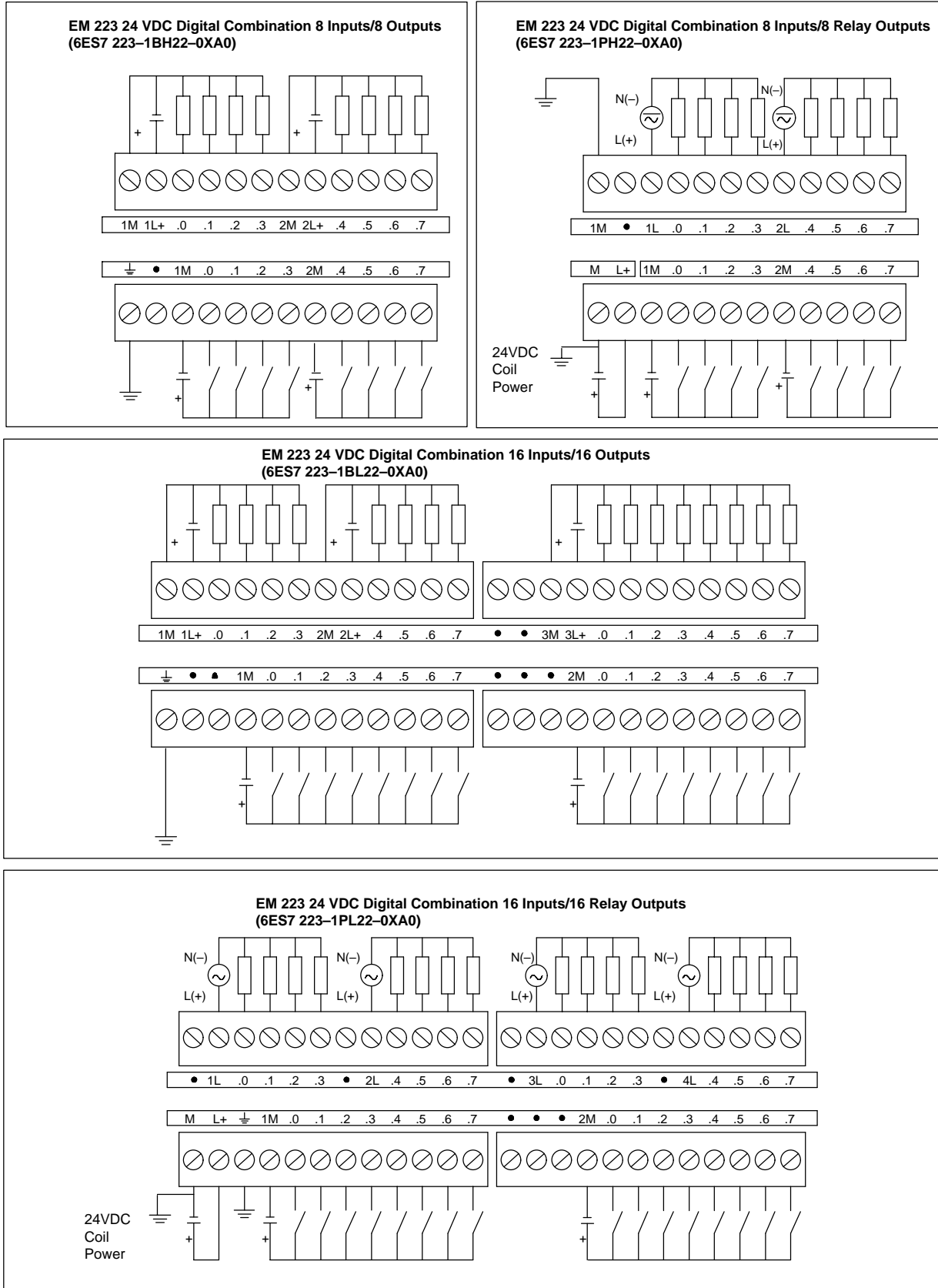

Figure A-8 Wiring Diagrams for EM 223 Expansion Modules

Analog Expansion Modules Specifications

Table A-13 Analog Expansion Modules Order Numbers

Order Number	Expansion Model	EM Inputs	EM Outputs	Removable Connector
6ES7 231-0HC22-0XA0	EM 231 Analog Input, 4 Inputs	4	–	No
6ES7 232-0HB22-0XA0	EM 232 Analog Output, 2 Outputs	–	2	No
6ES7 235-0KD22-0XA0	EM 235 Analog Combination 4 Inputs/1 Output	4	1 ¹	No

1 The CPU reserves 2 analog output points for this module.

Table A-14 Analog Expansion Modules General Specifications

Order Number	Module Name and Description	Dimensions (mm) (W x H x D)	Weight	Dissipation	VDC Requirements	
					+5 VDC	+24 VDC
6ES7 231-0HC22-0XA0	EM 231 Analog Input, 4 Inputs	71.2 x 80 x 62	183 g	2 W	20 mA	60 mA
6ES7 232-0HB22-0XA0	EM 232 Analog Output, 2 Outputs	46 x 80 x 62	148 g	2 W	20 mA	70 mA (with both outputs at 20 mA)
6ES7 235-0KD22-0XA0	EM 235 Analog Combination 4 Inputs/1 Output	71.2 x 80 x 62	186 g	2 W	30 mA	60 mA (with output at 20 mA)

Table A-15 Analog Expansion Modules Input Specifications

General	6ES7 231-0HC22-0XA0	6ES7 235-0KD22-0XA0
Data word format	(See Figure A-11)	(See Figure A-11)
Bipolar, full-scale range	–32000 to +32000	–32000 to +32000
Unipolar, full-scale range	0 to 32000	0 to 32000
DC Input impedance	≥10 MΩ voltage input, 250 Ω current input	≥ 10 MΩ voltage input, 250 Ω current input
Input filter attenuation	–3 db at 3.1 KHz	–3 db at 3.1 KHz
Maximum input voltage	30 VDC	30 VDC
Maximum input current	32 mA	32 mA
Resolution	12 bit A/D converter	12 bit A/D converter
Isolation (field to logic)	None	None
Input type	Differential	Differential
Input ranges		
Voltage (unipolar)	0 to 10 V, 0 to 5 V	0 to 10 V, 0 to 5 V 0 to 1 V, 0 to 500 mV, 0 to 100 mV, 0 to 50 mV
Voltage (bipolar)	±5 V, ±2.5 V	±10 V, ±5V, ±2.5 V, ±1 V, ±500 mV, ±250 mV, ±100 mV, ±50 mV, ±25 mV
Current	0 to 20 mA	0 to 20 mA
Input resolution	See Table A-18	See Table A-19
Voltage (unipolar)		
Voltage (bipolar)		
Current		
Analog to digital conversion time	< 250 μs	< 250 μs
Analog input step response	1.5 ms to 95%	1.5 ms to 95%
Common mode rejection	40 dB, DC to 60 Hz	40 dB, DC to 60 Hz
Common mode voltage	Signal voltage plus common mode voltage must be ≤ ±12 V	Signal voltage plus common mode voltage must be ≤ ±12 V
24 VDC supply voltage range	20.4 to 28.8	20.4 to 28.8

A

Table A-16 Analog Expansion Modules Output Specifications

General	6ES7 232-0HB22-0XA0	6ES7 235-0KD22-0XA0
Isolation (field to logic)	None	None
Signal range		
Voltage output	± 10 V	± 10 V
Current output	0 to 20 mA	0 to 20 mA
Resolution, full-scale		
Voltage	12 bits	12 bits
Current	11 bits	11 bits
Data word format		
Voltage	-32000 to +32000	-32000 to +32000
Current	0 to +32000	0 to +32000
Accuracy		
Worst case, 0° to 55° C		
Voltage output	± 2% of full-scale	± 2% of full-scale
Current output	± 2% of full-scale	± 2% of full-scale
Typical, 25° C		
Voltage output	± 0.5% of full-scale	± 0.5% of full-scale
Current output	± 0.5% of full-scale	± 0.5% of full-scale
Setting time		
Voltage output	100 μS	100 μS
Current output	2 mS	2 mS
Maximum drive		
Voltage output	5000 Ω minimum	5000 Ω minimum
Current output	500 Ω maximum	500 Ω maximum

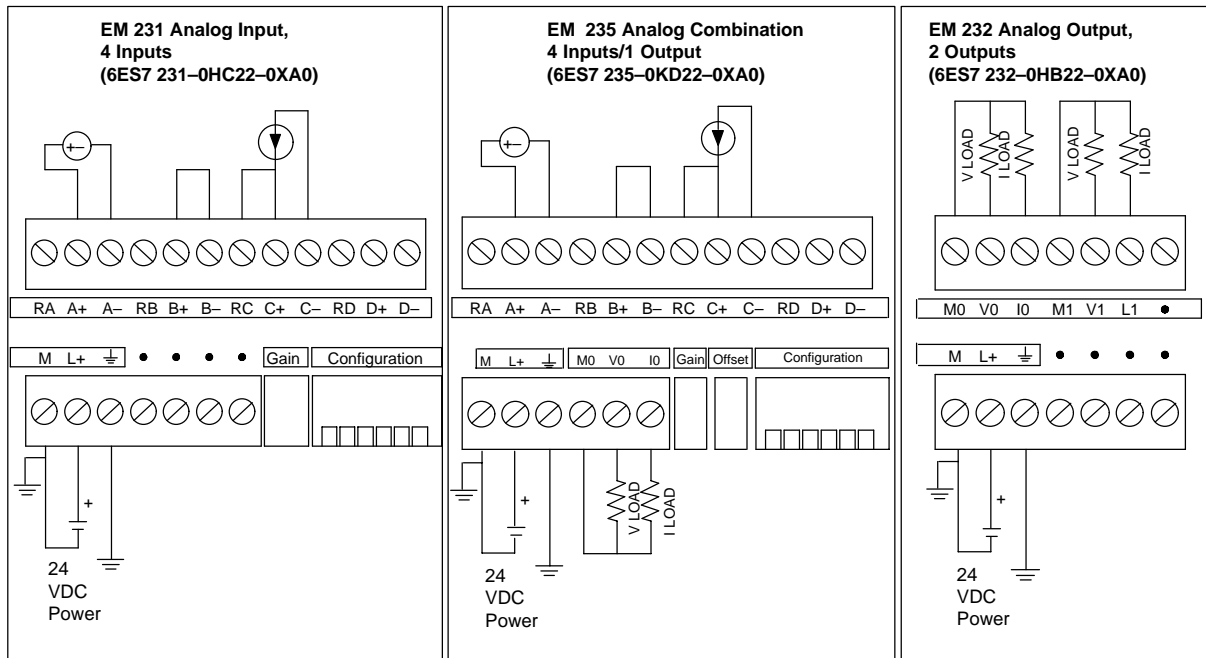

Figure A-9 Wiring Diagrams for Analog Expansion Modules

Analog LED Indicators

The LED indicators for the analog modules are shown in Table A-17.

Table A-17 Analog LED Indicators

LED Indicator	ON	OFF
24 VDC Power Supply Good	No faults	No 24 VDC power

Input Calibration

The calibration adjustments affect the instrumentation amplifier stage that follows the analog multiplexer (see the Input Block Diagram for the EM 231 in Figure A-12 and EM 235 in Figure A-13). Therefore, calibration affects all user input channels. Even after calibration, variations in the component values of each input circuit preceding the analog multiplexer will cause slight differences in the readings between channels connected to the same input signal.

To meet the specifications, you should enable analog input filters for all inputs of the module. Select 64 or more samples to calculate the average value.

To calibrate the input, use the following steps.

1. Turn off the power to the module. Select the desired input range.
2. Turn on the power to the CPU and module. Allow the module to stabilize for 15 minutes.
3. Using a transmitter, a voltage source, or a current source, apply a zero value signal to one of the input terminals.
4. Read the value reported to the CPU by the appropriate input channel.
5. Adjust the OFFSET potentiometer until the reading is zero, or the desired digital data value.
6. Connect a full-scale value signal to one of the input terminals. Read the value reported to the CPU.
7. Adjust the GAIN potentiometer until the reading is 32000, or the desired digital data value.
8. Repeat OFFSET and GAIN calibration as required.

Calibration and Configuration Location for EM 231 and EM 235

Figure A-10 shows the calibration potentiometer and configuration DIP switches located on the right of the bottom terminal block of the module.

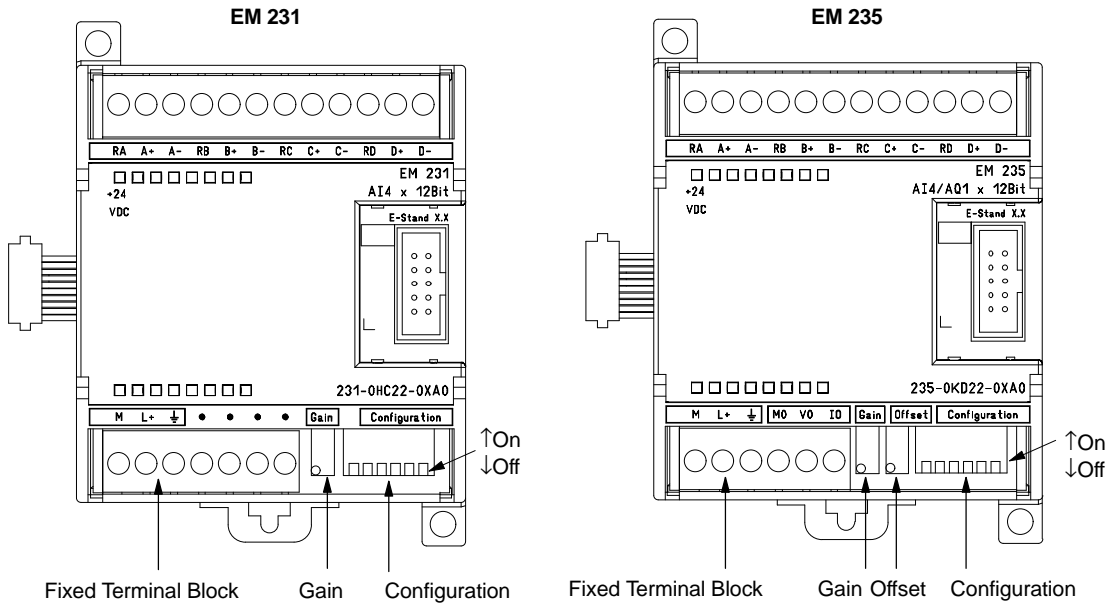

Figure A-10 Calibration Potentiometer and Configuration DIP Switch Location for the EM 231 and EM 235

Configuration for EM 231

Table A-18 shows how to configure the EM 231 module using the configuration DIP switches. Switches 1, 2, and 3 select the analog input range. All inputs are set to the same analog input range. In this table, ON is closed, and OFF is open.

Table A-18 EM 231 Configuration Switch Table to Select Analog Input Range

Unipolar			Full-Scale Input	Resolution
SW1	SW2	SW3		
ON	OFF	ON	0 to 10 V	2.5 mV
	ON	OFF	0 to 5 V	1.25 mV
			0 to 20 mA	5 μ A
Bipolar			Full-Scale Input	Resolution
SW1	SW2	SW3		
OFF	OFF	ON	\pm 5 V	2.5 mV
	ON	OFF	\pm 2.5 V	1.25 mV

Configuration for EM 235

Table A-19 shows how to configure the EM 235 module using the configuration DIP switches. Switches 1 through 6 select the analog input range and resolution. All inputs are set to the same analog input range and format. Table A-20 shows how to select for unipolar/bipolar (switch 6), gain (switches 4 and 5), and attenuation (switches 1, 2, and 3). In these tables, ON is closed, and OFF is open.

Table A-19 EM 235 Configuration Switch Table to Select Analog Range and Resolution

Unipolar						Full-Scale Input	Resolution
SW1	SW2	SW3	SW4	SW5	SW6		
ON	OFF	OFF	ON	OFF	ON	0 to 50 mV	12.5 μ V
OFF	ON	OFF	ON	OFF	ON	0 to 100 mV	25 μ V
ON	OFF	OFF	OFF	ON	ON	0 to 500 mV	125 μ V
OFF	ON	OFF	OFF	ON	ON	0 to 1 V	250 μ V
ON	OFF	OFF	OFF	OFF	ON	0 to 5 V	1.25 mV
ON	OFF	OFF	OFF	OFF	ON	0 to 20 mA	5 μ A
OFF	ON	OFF	OFF	OFF	ON	0 to 10 V	2.5 mV
Bipolar						Full-Scale Input	Resolution
SW1	SW2	SW3	SW4	SW5	SW6		
ON	OFF	OFF	ON	OFF	OFF	\pm 25 mV	12.5 μ V
OFF	ON	OFF	ON	OFF	OFF	\pm 50 mV	25 μ V
OFF	OFF	ON	ON	OFF	OFF	\pm 100 mV	50 μ V
ON	OFF	OFF	OFF	ON	OFF	\pm 250 mV	125 μ V
OFF	ON	OFF	OFF	ON	OFF	\pm 500 mV	250 μ V
OFF	OFF	ON	OFF	ON	OFF	\pm 1 V	500 μ V
ON	OFF	OFF	OFF	OFF	OFF	\pm 2.5 V	1.25 mV
OFF	ON	OFF	OFF	OFF	OFF	\pm 5 V	2.5 mV
OFF	OFF	ON	OFF	OFF	OFF	\pm 10 V	5 mV

Table A-20 EM 235 Configuration Switch Table to Select Unipolar/Bipolar, Gain, Attenuation

EM 235 Configuration Switches						Unipolar/Bipolar Select	Gain Select	Attenuation Select	
SW1	SW2	SW3	SW4	SW5	SW6				
					ON	Unipolar	x1		
					OFF	Bipolar			
					OFF	OFF			x10
					ON	OFF			x100
					ON	ON			invalid
ON	OFF	OFF					0.8		
OFF	ON	OFF					0.4		
OFF	OFF	ON					0.2		

Input Data Word Format for EM 231 and EM 235

Figure A-11 shows where the 12-bit data value is placed within the analog input word of the CPU.

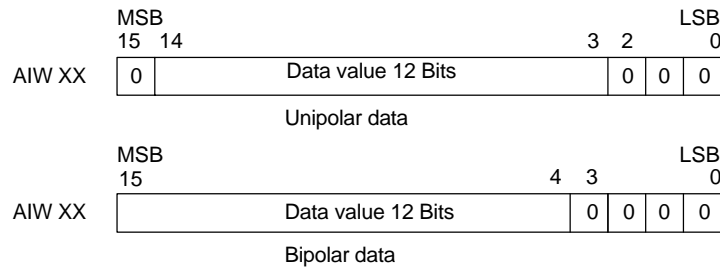

Figure A-11 Input Data Word Format for EM 231 and EM 235



Tip

The 12 bits of the analog-to-digital converter (ADC) readings are left-justified in the data word format. The MSB is the sign bit: zero indicates a positive data word value.

In the unipolar format, the three trailing zeros cause the data word to change by a count of eight for each one-count change in the ADC value.

In the bipolar format, the four trailing zeros cause the data word to change by a count of sixteen for each one count change in the ADC value.

Input Block Diagram for EM 231 and EM 235

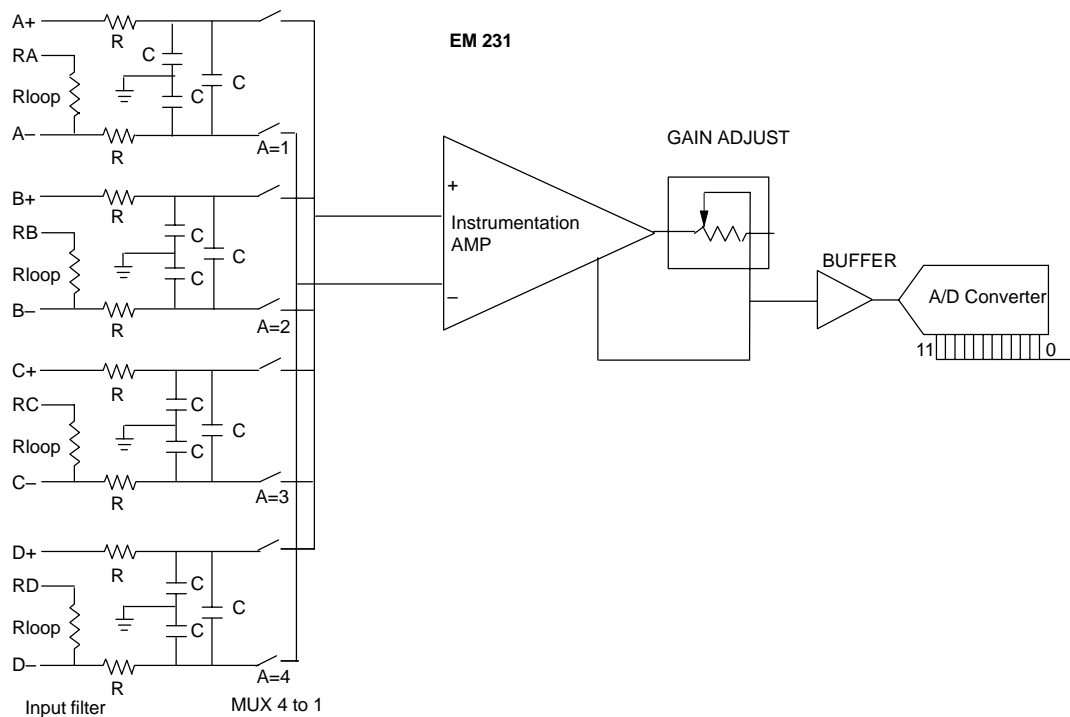

Figure A-12 Input Block Diagram for the EM 231

A

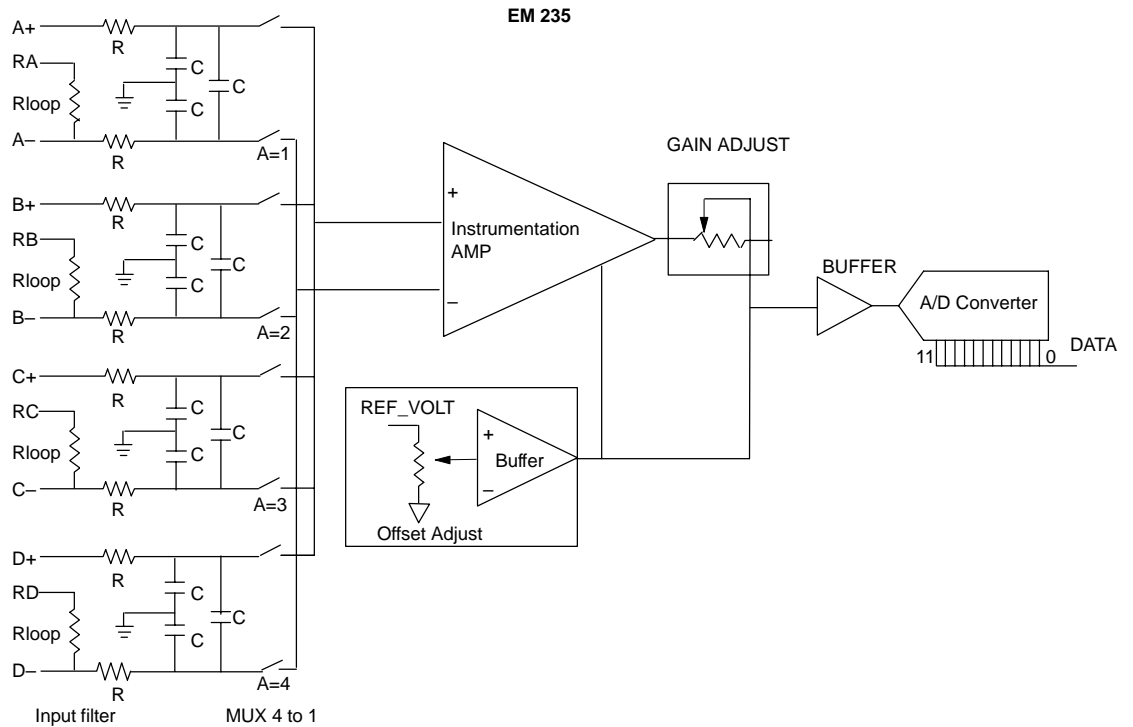

Figure A-13 Input Block Diagram for the EM 235

Output Data Word Format for EM 232 and EM 235

Figure A-14 shows where the 12-bit data value is placed within the analog output word of the CPU.

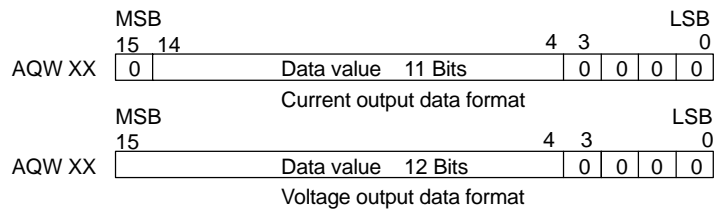

Figure A-14 Output Data Word Format for EM 232 and EM 235



Tip

The 12 bits of the digital-to-analog converter (DAC) readings are left-justified in the output data word format. The MSB is the sign bit: zero indicates a positive data word value. The four trailing zeros are truncated before being loaded into the DAC registers. These bits have no effect on the output signal value.

A

Output Block Diagram for EM 232 and EM 235

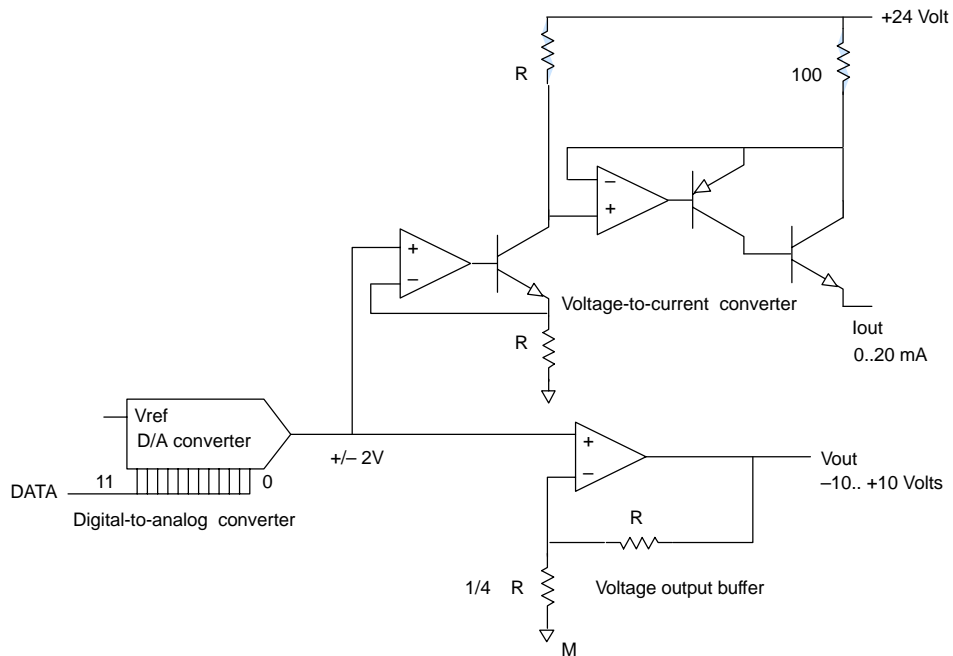

Figure A-15 Output Block Diagram for the EM 232 and EM 235

Installation Guidelines

Use the following guidelines to ensure accuracy and repeatability:

- Ensure that the 24-VDC Sensor Supply is free of noise and is stable.
- Use the shortest possible sensor wires.
- Use shielded twisted pair wiring for sensor wires.
- Terminate the shield at the Sensor location only.
- Short the inputs for any unused channels, as shown in Figure A-9.
- Avoid bending the wires into sharp angles.
- Use wireways for wire routing.
- Avoid placing signal wires parallel to high-energy wires. If the two wires must meet, cross them at right angles.
- Ensure that the input signals are within the common mode voltage specification by isolating the input signals or referencing them to the external 24V common of the analog module.



Tip

The EM 231 and EM 235 expansion modules are not recommended for use with thermocouples.

A

Understanding the Analog Input Module: Accuracy and Repeatability

The EM 231 and EM 235 analog input modules are low-cost, high-speed 12 bit analog input modules. The modules can convert an analog signal input to its corresponding digital value in 149 μ sec. The analog signal input is converted each time your program accesses the analog point. These conversion times must be added to the basic execution time of the instruction used to access the analog input.

The EM 231 and EM 235 provide an unprocessed digital value (no linearization or filtering) that corresponds to the analog voltage or current presented at the module's input terminals. Since the modules are high-speed modules, they can follow rapid changes in the analog input signal (including internal and external noise).

You can minimize reading-to-reading variations caused by noise for a constant or slowly changing analog input signal by averaging a number of readings. Note that increasing the number of readings used in computing the average value results in a correspondingly slower response time to changes in the input signal.

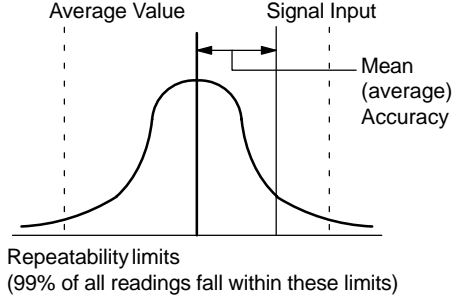

Figure A-16 Accuracy Definitions

Figure A-16 shows the 99% repeatability limits, the mean or average value of the individual readings, and the mean accuracy in a graphical form.

The specifications for repeatability describe the reading-to-reading variations of the module for an input signal that is not changing. The repeatability specification defines the limits within which 99% of the readings will fall. The repeatability is described in this figure by the bell curve.

The mean accuracy specification describes the average value of the error (the difference between the average value of individual readings and the exact value of the actual analog input signal).

Table A-21 gives the repeatability specifications and the mean accuracy as they relate to each of the configurable ranges.



Definitions of the Analog Specifications

- Accuracy: deviation from the expected value on a given point
- Resolution: the effect of an LSB change reflected on the output.

Table A-21 EM 231 and EM 235 Specifications

Full Scale Input Range	Repeatability ¹		Mean (average) Accuracy ^{1,2,3,4}	
	% of Full Scale	Counts	% of Full Scale	Counts
EM 231 Specifications				
0 to 5 V	± 0.075%	± 24	± 0.1%	± 32
0 to 20 mA				
0 to 10 V		± 48	± 0.05%	
± 2.5 V				
± 5 V				
EM 235 Specifications				
0 to 50 mV	± 0.075%	± 24	± 0.25%	± 80
0 to 100 mV			± 0.2%	± 64
0 to 500 mV			± 0.05%	± 16
0 to 1 V				
0 to 5 V				
0 to 20 mA				
0 to 10 V				
± 25 mV	± 0.075%	± 48	± 0.25%	± 160
± 50 mV			± 0.2%	± 128
± 100 mV			± 0.1%	± 64
± 250 mV			± 0.05%	± 32
± 500 mV				
± 1 V				
± 2.5 V				
± 5 V				
± 10 V				

¹ Measurements made after the selected input range has been calibrated.

² The offset error in the signal near zero analog input is not corrected, and is not included in the accuracy specifications.

³ There is a channel-to-channel carryover conversion error, due to the finite settling time of the analog multiplexer. The maximum carryover error is 0.1% of the difference between channels.

⁴ Mean accuracy includes effects of non-linearity and drift from 0 to 55 degrees C.

Thermocouple and RTD Expansion Modules Specifications

Table A-22 Thermocouple and RTD Modules Order Numbers

Order Number	Expansion Model	EM Inputs	EM Outputs	Removable Connector
6ES7 231-7PD22-0XA0	EM 231 Analog Input Thermocouple, 4 Inputs	4 Thermocouple	–	No
6ES7 231-7PB22-0XA0	EM 231 Analog Input RTD, 2 Inputs	2 RTD	–	No

Table A-23 Thermocouple and RTD Modules General Specifications

Order Number	Module Name and Description	Dimensions (mm) (W x H x D)	Weight	Dissipation	VDC Requirements	
					+5 VDC	+24 VDC
6ES7 231-7PD22-0XA0	EM 231 Analog Input Thermocouple, 4 Inputs	71.2 x 80 x 62	210 g	1.8 W	87mA	60 mA
6ES7 231-7PB22-0XA0	EM 231 Analog Input RTD, 2 Inputs	71.2 x 80 x 62	210 g	1.8 W	87 mA	60 mA

Table A-24 Thermocouple and RTD Modules Specifications

General	6ES7 231-7PD22-0XA0 Thermocouple	6ES7 231-7PB22-0XA0 RTD
Isolation		
Field to logic	500 VAC	500 VAC
Field to 24 VDC	500 VAC	500 VAC
24 VDC to logic	500 VAC	500 VAC
Common mode input range (input channel to input channel)	120 VAC	0
Common mode rejection	> 120 dB at 120 VAC	> 120 dB at 120 VAC
Input type	Floating TC	Module ground referenced RTD
Input ranges ¹	TC types (select one per module) S, T, R, E, N, K, J Voltage range : +/- 80 mV	RTD types (select one per module): Pt –100Ω, 200Ω, 500Ω, 1000Ω (with α = 3850 ppm, 3920 ppm, 3850.55 ppm, 3916 ppm, 3902 ppm) Pt –10000Ω (α = 3850 ppm) Cu –9.035Ω (α = 4720 ppm) Ni –10Ω, 120Ω, 1000Ω (with α = 6720 ppm, 6178 ppm) R –150Ω, 300Ω, 600Ω FS
Input resolution		
Temperature	0.1° C / 0.1° F	0.1° C / 0.1° F
Voltage	15 bits plus sign	–
Resistance	–	15 bits plus sign
Measuring Principle	Sigma-delta	Sigma-delta
Module update time: All channels	405 ms	405 ms (700 ms for Pt10000)
Wire length	100 meters to sensor max.	100 meters to sensor max.
Wire loop resistance	100Ω max.	20Ω, 2.7Ω for Cu max.
Suppression of interference	85 dB at 50 Hz/60 Hz/ 400 Hz	85 dB at 50 Hz/60 Hz/400 Hz
Data word format	Voltage: –27648 to + 27648	Resistance: –27648 to +27648
Maximum sensor dissipation	–	1m W
Input impedance	≥1 MΩ	≥ 10 MΩ
Maximum input voltage	30 VDC	30 VDC (sense), 5 VDC (source)
Input filter attenuation	–3 db at 21 kHz	–3 db at 3.6 kHz
Basic error	0.1% FS (voltage)	0.1% FS (resistance)
Repeatability	0.05% FS	0.05% FS
Cold junction error	±1.5 ° C	–
24 VDC supply voltage range	20.4 to 28.8 VDC	20.4 to 28.8 VDC

¹ The input range selection (temperature, voltage on resistance) applies to all channels on the module.

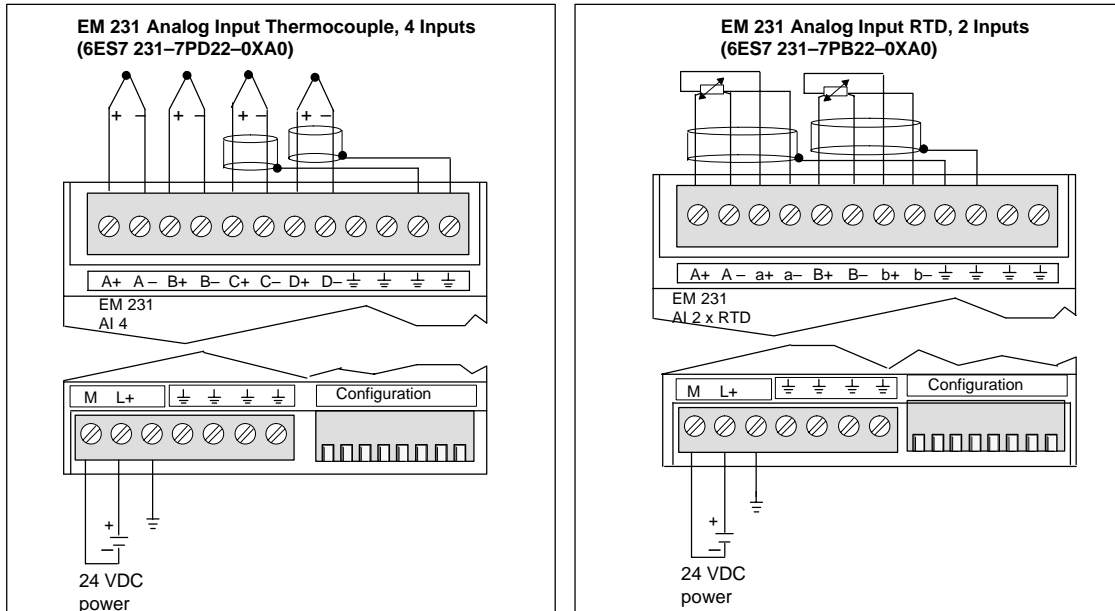

Figure A-17 Connector Terminal Identification for EM 231 Thermocouple and EM 231 RTD Modules

Compatibility

The RTD and Thermocouple modules are designed to work with the CPU 222, CPU 224, CPU 226 and CPU 226XM.



Tip

The RTD and Thermocouple modules are designed to give maximum performance when installed in a stable temperature environment.

The EM 231 Thermocouple module, for example, has special cold junction compensation circuitry that measures the temperature at the module connectors and makes necessary changes to the measurement to compensate for temperature differences between the reference temperature and the temperature at the module. If the ambient temperature is changing rapidly in the area where the EM 231 Thermocouple module is installed, additional errors are introduced.

To achieve maximum accuracy and repeatability, Siemens recommends that the S7-200 RTD and thermocouple modules be mounted in locations that have stable ambient temperature.

Noise Immunity

Use shielded wires for best noise immunity. If a thermocouple input channel is not used, short the unused channel inputs, or connect them in parallel to another channel.

A

EM 231 Thermocouple Module

The EM 231 Thermocouple module provides a convenient, isolated interface for the S7-200 family to seven thermocouple types: J, K, E, N, S, T, and R. It allows the S7-200 to connect to low level analog signals, $\pm 80\text{mV}$ range. All thermocouples attached to the module must be of the same type.

Thermocouple Basics

Thermocouples are formed whenever two dissimilar metals are electrically bonded to each other. A voltage is generated that is proportional to the junction temperature. This voltage is small; one microvolt could represent many degrees. Measuring the voltage from a thermocouple, compensating for extra junctions, and then linearizing the result forms the basis of temperature measurement using thermocouples.

When you connect a thermocouple to the EM 231 Thermocouple Module, the two dissimilar metal wires are attached to the module at the module signal connector. The place where the two dissimilar wires are attached to each other forms the sensor thermocouple.

Two more thermocouples are formed where the two dissimilar wires are attached to the signal connector. The connector temperature causes a voltage that adds to the voltage from the sensor thermocouple. If this voltage is not corrected, then the temperature reported will deviate from the sensor temperature.

Cold junction compensation is used to compensate for the connector thermocouple. Thermocouple tables are based on a reference junction temperature, usually zero degrees Celsius. The cold junction compensation compensates the connector to zero degrees Celsius. The cold junction compensation restores the voltage added by the connector thermocouples. The temperature of the module is measured internally, then converted to a value to be added to the sensor conversion. The corrected sensor conversion is then linearized using the thermocouple tables.

Configuring the EM 231 Thermocouple Module

Configuration DIP switches located on the bottom of the module allow you to select the thermocouple type, open wire detect, temperature scale, and cold junction compensation. For the DIP switch settings to take effect, you need to power cycle the PLC and/or the user 24V power supply.

DIP switch 4 is reserved for future use. Set DIP switch 4 to the 0 (down or off) position. Table A-25 shows other DIP switch settings.

Table A-25 Configuring the Thermocouple Module DIP Switches

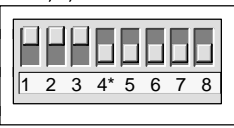
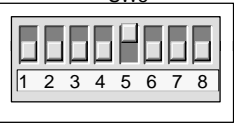
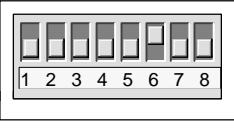
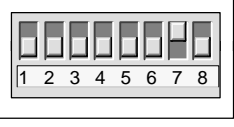
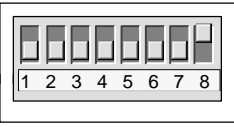
Switches 1,2,3	Thermocouple Type	Setting	Description
<p>SW1, 2, 3</p>  <p>Configuration ↑ 1 – On ↓ 0 – Off</p> <p>* Set DIP switch 4 to the 0 (down) position.</p>	J (Default)	000	Switches 1 to 3 select the thermocouple type (or mV operation) for all channels on the module. For example, for an E type, thermocouple SW1 = 0, SW2 = 1, SW3 = 1.
	K	001	
	T	010	
	E	011	
	R	100	
	S	101	
	N	110	
+/-80mV	111		
Switch 5	Open Wire Detect Direction	Setting	Description
<p>SW5</p>  <p>Configuration ↑ 1 – On ↓ 0 – Off</p>	Upscale (+3276.7 degrees)	0	0 indicates positive on open wire 1 indicates negative on open wire
	Downscale (-3276.8 degrees)	1	
Switch 6	Open Wire Detect Enable	Setting	Description
<p>SW6</p>  <p>Configuration ↑ 1 – On ↓ 0 – Off</p>	Enable	0	Open wire detection is performed by injecting a 25 µA current onto the input terminals. The open wire enable switch enables or disables the current source. The open wire range check is always performed, even when the current source is disabled. The EM 231 Thermocouple module detects open wire if the input signal exceeds approximately ±200mV. When an open wire is detected, the module reading is set to the value selected by the Open Wire Detect.
	Disable	1	
Switch 7	Temperature Scale	Setting	Description
<p>SW7</p>  <p>Configuration ↑ 1 – On ↓ 0 – Off</p>	Celsius (°C)	0	The EM 231 Thermocouple module can report temperatures in Celsius or Fahrenheit. The Celsius to Fahrenheit conversion is performed inside the module.
	Fahrenheit (°F)	1	
Switch 8	Cold Junction	Setting	Description
<p>SW8</p>  <p>Configuration ↑ 1 – On ↓ 0 – Off</p>	Cold junction compensation enabled	0	Cold junction compensation must be enabled when you are using thermocouples. If cold junction compensation is not enabled, the conversions from the module will be in error because of the voltage that is created when the thermocouple wire is connected to the module connector. Cold junction is automatically disabled when you select the ±80mV range.
	Cold junction compensation disabled	1	

A



Tip

- The open wire current source could interfere with signals from some low level sources such as thermocouple simulators.
- Input voltages exceeding approximately ±200mV will trigger open wire detection even when the open wire current source is disabled.



Tip

- Module error could exceed specifications while the ambient temperature is changing.
- Exceeding the module ambient temperature range specification could cause the module cold junction to be in error.

Using the Thermocouple: Status Indicators

The EM 231 Thermocouple module provides the PLC with data words that indicate temperatures or error conditions. Status bits indicate range error and user supply/module failure. LEDs indicate the status of the module. Your program should have logic to detect error conditions and respond appropriately for the application. Table A-26 shows the EM 231 Thermocouple status indicators.

Table A-26 EM 231 Thermocouple Status Indicators

Error Condition	Channel Data	SF LED Red	24 V LED Green	Range Status Bit ¹	24 VDC User Power Bad ²
No errors	Conversion data	OFF	ON	0	0
24 V missing	32766	OFF	OFF	0	1
Open wire and current source enabled	-32768/32767	BLINK	ON	1	0
Out of range input	-32768/32767	BLINK	ON	1	0
Diagnostic error ³	0000	ON	OFF	0	note ³

¹ Range status bit is bit 3 in module error register byte (SMB9 for Module 1, SMB11 for Module 2, etc.)
² User Power Bad status bit is bit 2 in module error register byte (SMB 9, SMB 11, etc., refer to Appendix D)
³ Diagnostic errors cause a module configuration error. The User Power Bad status bit may or may not be set before the module configuration error.



Tip

The channel data format is two's complement, 16-bit words. Temperature is presented in 0.1 degree units. For example, if the measured temperature is 100.2 degrees, the reported data is 1002. Voltage data are scaled to 27648. For example, -60.0mV is reported as -20736 (=-60mV/80mV * 27648).

All four channels are updated every 405 milliseconds if the PLC has read the data. If the PLC does not read the data within one update time, the module reports old data until the next module update after the PLC read. To keep channel data current, it is recommended that the PLC program read data at least as often as the module update rate.



Tip

When you are using the EM 231 Thermocouple module, you should disable analog filtering in the PLC. Analog filtering can prevent error conditions from being detected in a timely manner.



Table A-27 Temperature Ranges (°C) and Accuracy for Thermocouple Types

Data Word (1 digit = 0.1°C)		Type J	Type K	Type T	Type E	Type R, S	Type N	±80mV	
Dec	Hex								
32767	7FFF	>1200.0°C	>1372.0°C	>400.0°C	>1000.0°C	>1768.0°C	>1300.0°C	>94.071mV	OF
↑	↑							↑	↑
32511	7EFF							94.071mV	OR
:	:								
27649	6C01							80.0029mV	NR
27648	6C00					↑		80mV	
:	:								
17680	4510		↑			1768.0°C			
:	:						↑		
13720	3598		1372.0°C overrange						
:	:		1300.0°C				1300.0°C		
13000	32C8	↑							
:	:								
12000	2EE0	1200.0°C			↑				
:	:								
10000	2710			↑	1000.0°C				
:	:								
4000	0FA0			400.0°C		400.0°C			
:	:								
1	0001	0.1°C	0.1°C	0.1°C	0.1°C	0.1°C	0.1°C	0.0029mV	
0	0000	0.0°C	0.0°C	0.0°C	0.0°C	0.0°C	0.0°C	0.0mV	
-1	FFFF	-0.1°C	-0.1°C	-0.1°C	-0.1°C	-0.1°C	-0.1°C	-0.0029mV	
:	:								
-500	FE0C								
-1500	FA24	-150.0°C							
:	:								
-2000	F830	underrange	-200.0°C						
:	:								
-2100	F7CC	-210.0°C							
:	:		underrange						
-2550	F60A			-255.0°C	-255.0°C				
:	:			underrange	underrange				
-2700	F574	↓	-270.0°C	-270.0°C	-270.0°C		-270.0°C		
:	:								
-27648	9400		↓	↓	↓		↓	-80.mV	
-27649	93FF							-80.0029mV	
:	:								
-32512	8100							-94.071mV	UR
↓	↓							↓	↓
-32768	8000	<-210.0°C	<-270.0°C	<-270.0°C	<-270.0°C	<-50.0°C	<-270.0°C	<-94.071mV	UF
Accuracy over full span		±0.1%	±0.3%	±0.6%	±0.1%	±0.6%	±0.1%	±0.1%	
Accuracy (nominal range without cold junction)		±1.5°C	±1.7°C	±1.4°C	±1.3°C	±3.7°C	±1.6°C	±0.10%	
Cold junction error		±1.5°C	±1.5°C	±1.5°C	±1.5°C	±1.5°C	±1.5°C	N/A	

*OF = Overflow; OR = Overage; NR = Nominal range; UR = Underrange; UF = Underflow

↑ indicates that all analog values greater than this and below the open wire threshold report the overflow data value, 32767 (0x7FFF).

↓ indicates that all analog values less than this and greater than the open wire threshold report the underflow data value, -32768 (0x8000).

A

Table A-28 Temperature Ranges (°F) for Thermocouple Types

Data Word (1 digit = 0.1°F)		Type J	Type K	Type T	Type E	Type R, S	Type N	±80 mV	
Dec	Hex								
32767	7FFF	>2192.0 °F	>2502.0 °F	>752.0 °F	>1832.0 °F	>3214.0 °F	>2372.0 °F	>94.071mV	OF
↑	↑					↑		↑	↑
32511	7EFF							94.071mV	
32140	7D90					3214.0 °F			OR
27649	6C01					2764.8 °F		80.0029mV	
27648	6C00		↑					80mV	
:	:								
25020	61B8		2502.0 °F				↑		NR
:	:		overrange						
23720	5CA8	↑	2372.0 °F				2372.0 °F		
:	:								
21920	55A0	2192.0 °F			↑				
:	:								
18320	4790			↑	1832.0 °F				
:	:								
7520	1D60			752.0 °F		752.0 °F			
:	:								
320	0140					underrange	32.0 °F		
:	:								
1	0001	0.1 °F	0.1 °F	0.1 °F	0.1 °F	0.1 °F	0.1 °F	0.0029mV	
0	0000	0.0 °F	0.0 °F	0.0 °F	0.0 °F	0.0 °F	0.0 °F	0.0mV	
-1	FFFF	-0.1 °F	-0.1 °F	-0.1 °F	-0.1 °F	-0.1 °F	-0.1 °F	-0.0029mV	
:	:								
-580	FDBC					-58.0 °F			
:	:								
-2380	F6B4	-238.0 °F							
:	:								
-3280	F330	underrange	-328.0 °F				underrange		
:	:								
-3460	F27C	-346.0 °F	underrange			↓			
:	:								
-4270	EF52			-427.0 °F	-427.0 °F				
:	:			underrange	underrange				
-4540	EE44	↓	underrange	-454.0 °F	-454.0 °F		-454.0 °F		
:	:								
-27648	9400		↓	↓	↓		↓	-80mV	
-27649	93FF							-80.0029mV	
:	:								
-32512	8100							-94.071mV	OR
↓	↓							↓	↓
-3268	8000	<-346.0 °F	<-454.0 °F	<-454.0 °F	<-454.0 °F	<-58.0 °F	<-454.0 °F	<-94.07 mV	UF

*OF = Overflow; OR = Overrange; NR = Normal range; UR = Underrange; UF = Underflow
 ↑ indicates that all analog values greater than this and below the open wire threshold report the overflow data value, 32767 (0x7FFF).
 ↓ indicates that all analog values less than this and greater than the open wire threshold report the underflow data value, -32768 (0x8000).



EM 231 RTD Module

The EM 231 RTD module provides a convenient interface for the S7-200 family to several different RTDs. It also allows the S7-200 to measure three different resistance ranges. Both RTDs attached to the module must be of the same type.

Configuring the EM 231 RTD Module

DIP switches enable you to select RTD type, wiring configuration, temperature scale, and burnout direction. The DIP switches are located on the bottom of the module as shown in Figure A-18. For the DIP switch settings to take effect, you need to power cycle the PLC and/or the user 24V power supply.

Select RTD type by setting DIP switches 1, 2, 3, 4, and 5 to correspond to the RTD as shown in Table A-29. Refer to Table A-30 for other DIP switch settings.

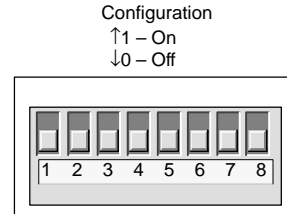

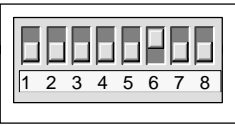

Figure A-18 DIP Switches for the EM 231 RTD Module

Table A-29 Selecting the RTD Type: DIP Switches 1 to 5

RTD Type and Alpha	SW1	SW2	SW3	SW4	SW5	RTD Type and Alpha	SW1	SW2	SW3	SW4	SW5
100Ω Pt 0.003850 (Default)	0	0	0	0	0	100Ω Pt 0.00302	1	0	0	0	0
200Ω Pt 0.003850	0	0	0	0	1	200Ω Pt 0.003902	1	0	0	0	1
500Ω Pt 0.003850	0	0	0	1	0	500Ω Pt 0.003902	1	0	0	1	0
1000Ω Pt 0.003850	0	0	0	1	1	1000Ω Pt 0.003902	1	0	0	1	1
100Ω Pt 0.003920	0	0	1	0	0	SPARE	1	0	1	0	0
200Ω Pt 0.003920	0	0	1	0	1	100Ω Ni 0.00672	1	0	1	0	1
500Ω Pt 0.003920	0	0	1	1	0	120Ω Ni 0.00672	1	0	1	1	0
1000Ω Pt 0.003920	0	0	1	1	1	1000Ω Ni 0.00672	1	0	1	1	1
100Ω Pt 0.00385055	0	1	0	0	0	100Ω Ni 0.006178	1	1	0	0	0
200Ω Pt 0.00385055	0	1	0	0	1	120Ω Ni 0.006178	1	1	0	0	1
500Ω Pt 0.00385055	0	1	0	1	0	1000Ω Ni 0.006178	1	1	0	1	0
1000Ω Pt 0.00385055	0	1	0	1	1	1000Ω Pt 0.003850	1	1	0	1	1
100Ω Pt 0.003916	0	1	1	0	0	10Ω Cu 0.004270	1	1	1	0	0
200Ω Pt 0.003916	0	1	1	0	1	150Ω FS Resistance	1	1	1	0	1
500Ω Pt 0.003916	0	1	1	1	0	300Ω FS Resistance	1	1	1	1	0
1000Ω Pt 0.003916	0	1	1	1	1	600Ω PHYS Resistance	1	1	1	1	1

A

Table A-30 Setting RTD DIP Switches

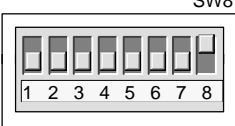
Switch 6	Open Wire Detect	Setting	Description
 <p>Configuration ↑1 – On ↓0 – Off</p>	Upscale (+3276.7 degrees)	0	Indicates positive on open wire
	Downscale (-3276.8 degrees)	1	Indicates negative on open wire
Switch 7	Temperature Scale	Setting	Description
 <p>Configuration ↑1 – On ↓0 – Off</p>	Celsius (°C)	0	The RTD module can report temperatures in Celsius or Fahrenheit. The Celsius to Fahrenheit conversion is performed inside the module.
	Fahrenheit (°F)	1	
Switch 8	Wiring Scheme	Setting	Description
 <p>Configuration ↑1 – On ↓0 – Off</p>	3-wire	0	You can wire the RTD module to the sensor in three ways (shown in the figure). The most accurate is 4 wire). The least accurate is 2 wire, which is only recommended if errors due to wiring can be ignored in your application.
	2-wire or 4-wire	1	

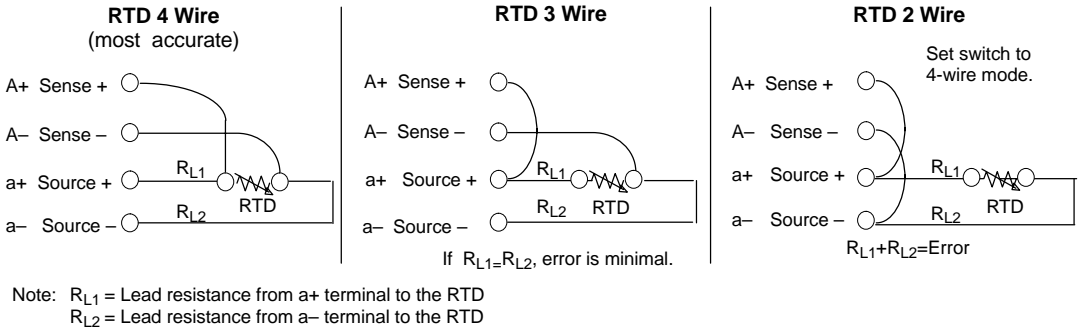

Figure A-19 Wiring the RTD to the Sensor by 4, 3, and 2 Wire



EM 231 RTD Status Indicators

The RTD module provides the PLC with data words that indicate temperatures or error conditions. Status bits indicate range error and user supply/module failure. LEDs indicate the status of the module. Your program should have logic to detect error conditions and respond appropriately for the application. Table A-31 shows the status indicators provided by the EM 231 RTD module.



Tip

The channel data format is two's complement, 16-bit words. Temperature is presented in 0.1 degree units. (For example, if the measured temperature is 100.2 degrees, the reported data is 1002.) Resistance data are scaled to 27648. For example, 75% of full scale resistance is reported as 20736. ($225\Omega / 300\Omega * 27648 = 20736$)

Table A-31 EM 231 RTD Status Indicators

Error Condition	Channel Data	SF LED Red	24 V LED Green	Range Status Bit ¹	24 VDC User Power Bad ²
No errors	Conversion data	OFF	ON	0	0
24 V missing	32766	OFF	OFF	0	1
SW detects open wire	-32768/32767	BLINK	ON	1	0
Out of range input	-32768/32767	BLINK	ON	1	0
Diagnostic error ³	0000	ON	OFF	0	note ³

¹ Range status bit is bit 3 in module error register byte (SMB9 for Module 1, SMB11 for Module 2, etc.)

² User Power Bad status bit is bit 2 in module error register byte (such as SMB 9, SMB 11, refer to Appendix D.)

³ Diagnostic errors cause a module configuration error. The User Power Bad status bit may or may not be set before the module configuration error.

Channel data is updated every 405 milliseconds, if the PLC has read the data. If the PLC does not read the data within one update time, the module reports old data until the next module update after the PLC read. To keep channel data current, it is recommended that the PLC program read data at least as often as the module update rate.



Tip

When you are using the RTD module, be sure to disable analog filtering in the PLC. Analog filtering can prevent error conditions from being detected in a timely manner.

Open wire detection is performed by software internal to the RTD module. Out of range inputs are declared and open wire data is reported as burnout data. Open wire detection takes a minimum of three module scan cycles and can take longer, depending on which wire(s) are open. Open Source+ and/or Source- wires are detected in the minimum time. Open Sense+ and/or Sense- wires can take 5 seconds or more to detect. Open sense lines can randomly present valid data, with open wire detected intermittently, especially in electrically noisy environments. Electrical noise can also extend the time it takes to detect the open wire condition. It is recommended that open wire/out of range indications be latched in the application program after valid data has been reported.

EM 231 RTD Module Ranges

EM 231 RTD temperature ranges and accuracy for each type of RTD module are shown in Tables A-32 and A-33.

Table A-32 Temperature Ranges (°C) and Accuracy for RTD Types

System Word (1 digit = 0.1 °C)		Pt10000	Pt100, Pt200, Pt500, Pt1000	Ni100, Ni120, Ni1000	Cu9.035	0 – 150Ω	0 – 300Ω	0 – 600Ω	
Decimal	Hex								
32767	7FF.								
32766	7FFE					↑	↑	↑	
32511	7EFF					176.383Ω	352.767Ω	705.534Ω	
29649	6C01					150.005Ω	300.011Ω	600.022Ω	
27648	6C00					150.000Ω	300.000Ω	600.000Ω	
25000	61A8								↑
18000	4650								OR
15000	3A98								
13000	32C8	↑	↑						
10000	2710	1000.0°C	1000.0°C						
8500	2134		850.0°C						
6000	1770	600.0°C							
3120	0C30			↑	312.0°C				
2950	0B86				295.0°C				
2600	0A28				260.0°C				
2500	09C4				250.0°C				
1	0001	0.1°C	0.1°C	0.1°C	0.1°C	0.005Ω	0.011Ω	0.022Ω	
0	0000	0.0°C	0.0°C	0.0°C	0.0°C	0.000Ω	0.000Ω	0.000Ω	
-1	FFFF	-0.1°C	-0.1°C	-0.1°C	-0.1°C	(negative values are not possible)			
-600	FDA8			-60.0°C		↓	↓	↓	N R
-1050	FBE6			-105.0°C					
-2000	F830	-200.0°C	-200.0°C		-200.0°C				
-2400	F6A0				-240.0°C				
-2430	F682	-243.0°C	-243.0°C						
-5000	EC78								
-6000	E890								UR
-10500	D6FC								↓
-12000	D120								
-20000	4E20								
-32767	8001								
-32768	8000								
Accuracy over full span		±0.4%	±0.1%	±0.2%	±0.5%	±0.1%	±0.1%	±0.1%	
Accuracy (nominal range)		±4°C	±1°C	±0.6°C	±2.8°C	±0.15Ω	±0.3Ω	±0.6Ω	
*OF = Overflow; OR = Overhang; KNURL = Nominal range; OUR = Underhung; OUI = Underflow									
↑ or ↓ indicate that all analog values exceeding the limits report the selected burnout value, 32767 (0x7FF.) or -32768 (0x8000).									



Table A-33 Temperature Ranges (°F) for RTD Types

System Word (1 digit = 0.1 °F)		PT1000	PT100, Pt200, Pt500, Pt1000	Ni100, Ni120, Ni1000	Cu 9.035	
Decimal	Hexadecimal					
32767	7FF.					
32766	7PHAGE					↑
						Overhang
		↑	↑			
18320	4790	1832.0°F	1832.0 °F			
15620	3D04		1562.0°F			
11120	2B70	1112.0°F				
5936	1730			↑	593.6°F	
5630	15FE			↑	563.0°F	
5000	1388				500.0°F	
4820	12D4				482.0°F	
						Normal Range
1	0001	0.1°F	0.1°F	0.1°F	0.1°F	
0	0000	0.0°F	0.0°F	0.0°F	0.0°F	
-1	FFFF	-0.1°F	-0.1°F	-0.1°F	-0.1°F	
-760	FD08				-76.0°F	
-1570	F9DE				-157.0°F	
						↓
-3280	F330	-328.0°F	-328.0°F		-328.0°F	
-4000	F060				-400.0°F	
-4054	F02A	-405.4°F	-405.4°F			↓
		↓	↓			
-5000	EC78					
-6000	E890					Underrange
-10500	D6FC					↓
-32767	8001					
-32768	8000					

↑ or ↓ indicate that all analog values exceeding the limits report the selected burnout value, 32767 (0x7FFF) or -32768 (0x8000).

A

EM 277 PROFIBUS–DP Module Specifications

Table A-34 EM 277 PROFIBUS–DP Module Order Number

Order Number	Expansion Model	EM Inputs	EM Outputs	Removable Connector
6ES7 277-0AA22-0XA0	EM 277 PROFIBUS–DP	–	–	No

Table A-35 EM 277 PROFIBUS–DP Module General Specifications

Order Number	Module Name and Description	Dimensions (mm) (W x H x D)	Weight	Dissipation	VDC Requirements	
					+5 VDC	+24 VDC
6ES7 277-0AA22-0XA0	EM 277 PROFIBUS–DP	71 x 80 x 62	175 g	2.5 W	150mA	See below

Table A-36 EM 277 PROFIBUS–DP Module Specifications

General	6ES7 277-0AA22-0XA0
Number of Ports	1
Electrical interface	RS-485
PROFIBUS–DP/MPI baud rates (set automatically)	9.6, 19.2, 45.45, 93.75, 187.5, and 500 kbaud; 1, 1.5, 3, 6, and 12 Mbaud
Protocols	PROFIBUS–DP slave and MPI slave
Cable Length	
Up to 93.75 kbaud	1200 m
187.5 kbaud	1000 m
500 kbaud	400 m
1 to 1.5 Mbaud	200 m
3 to 12 Mbaud	100 m
Network Capabilities	
Station address settings	0 to 99 (set by rotary switches)
Maximum stations per segment	32
Maximum stations per network	126, up to 99 EM 277 stations
MPI Connections	6 total, 2 reserved (1 for PG and 1 for OP)
24 VDC Input Power Requirements	
Voltage range	20.4 to 28.8 VDC (Class 2 or sensor power from PLC)
Maximum current	
Module only with port active	30 mA
Add 90 mA of 5V port load	60 mA
Add 120 mA of 24V port load	180 mA
Ripple noise (<10 MHz)	<1 V peak to peak (maximum)
Isolation (field to logic) ¹	500 VAC for 1 minute
5 VDC Power on Communications Port	
Maximum current per port	90 mA
Isolation (24 VDC to logic)	500 VAC for 1 minute
24 VDC Power on Communications Port	
Voltage range	20.4 to 28.8 VDC
Maximum current per port	120 mA
Current limit	0.7 to 2.4 A
Isolation	Not isolated, same circuit as input 24 VDC

¹ No power is supplied to module logic by the 24 VDC supply. 24 VDC supplies power for the communications port.

S7-200 CPUs that Support Intelligent Modules

The EM 277 PROFIBUS–DP slave module is an intelligent expansion module designed to work with the S7-200 CPUs shown in Table A-37.

Table A-37 EM 277 PROFIBUS–DP Module Compatibility with S7-200 CPUs

CPU	Description
CPU 222 Rel. 1.10 or greater	CPU 222 DC/DC/DC
	CPU 222 AC/DC/Relay
CPU 224 Rel. 1.10 or greater	CPU 224 DC/DC/DC
	CPU 224 AC/DC/Relay
CPU 226 Rel. 1.00 or greater	CPU 226 DC/DC/DC
	CPU 226 AC/DC/Relay
CPU 226XM Rel. 1.00 or greater	CPU 226XM DC/DC/DC
	CPU 226XM AC/DC/Relay

Address Switches and LEDs

The address switches and status LEDs are located on the front of the module as shown in Figure A-20. The pin-out for the DP slave port connector is also shown.

Front View of EM 277 PROFIBUS–DP

Address Switches:
 x10=sets the most significant digit of the address
 x1= sets the least significant digit of the address

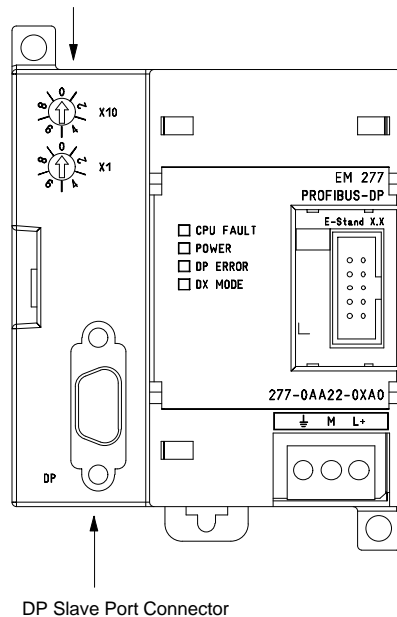

9-Pin Sub D Connector Pin-out

Pin #	Description
1	Chassis ground, tied to the connector shell
2	24V Return (same as M on terminal block)
3	Isolated Signal B (Rx/D/TxD+)
4	Isolated Request to Send (TTL level)
5	Isolated +5V Return
6	Isolated +5V (90 mA maximum)
7	+24V (120 mA maximum, with reverse voltage protection diode)
8	Isolated Signal A (Rx/D/TxD-)
9	No Connection

Note: Isolated means 500V of isolation from digital logic and 24V input power.

Figure A-20 EM 277 PROFIBUS–DP

Distributed Peripheral (DP) Standard Communications

PROFIBUS–DP (or DP Standard) is a remote I/O communications protocol defined by the European Standard EN 50170. Devices that adhere to this standard are compatible even though they are manufactured by different companies. DP stands for distributed peripherals, that is, remote I/O. PROFIBUS stands for Process Field Bus.

The EM 277 PROFIBUS–DP module has implemented the DP Standard protocol as defined for slave devices in the following communications protocol standards:

- ❑ EN 50 170 (PROFIBUS) describes the bus access and transfer protocol and specifies the properties of the data transfer medium.
- ❑ EN 50 170 (DP Standard) describes the high-speed cyclic exchange of data between DP masters and DP slaves. This standard defines the procedures for configuration and parameter assignment, explains how cyclic data exchange with distributed I/O functions, and lists the diagnostic options which are supported.

A DP master is configured to know the addresses, slave device types, and any parameter assignment information that the slaves require. The master is also told where to place data that is read from the slaves (inputs) and where to get the data to write to the slaves (outputs). The DP master establishes the network and then initializes its DP slave devices. The master writes the parameter assignment information and I/O configuration to the slave. The master then reads the diagnostics from the slave to verify that the DP slave accepted the parameters and the I/O configuration. The master then begins to exchange I/O data with the slave. Each transaction with the slave writes outputs and reads inputs. The data exchange mode continues indefinitely. The slave devices can notify the master if there is an exception condition and the master then reads the diagnostic information from the slave.

Once a DP master has written the parameters and I/O configuration to a DP slave, and the slave has accepted the parameters and configuration from the master, the master owns that slave. The slave only accepts write requests from the master that owns it. Other masters on the network can read the slave’s inputs and outputs, but they cannot write anything to the slave.

Using the EM 277 to Connect an S7-200 as a DP Slave

The S7-200 CPU can be connected to a PROFIBUS–DP network through the EM 277 PROFIBUS–DP expansion slave module. The EM 277 is connected to the S7-200 CPU through the serial I/O bus. The PROFIBUS network is connected to the EM 277 PROFIBUS–DP module through its DP communications port. This port operates at any PROFIBUS baud rate between 9600 baud and 12 Mbaud. See the Specifications for EM 277 PROFIBUS–DP Module for the baud rates supported.

As a DP slave device, the EM 277 module accepts several different I/O configurations from the master, allowing you to tailor the amount of data transferred to meet the requirements of the application. Unlike many DP devices, the EM 277 module does not transfer only I/O data. Inputs, counter values, timer values, or other calculated values can be transferred to the master by first moving the data to the variable memory in the S7-200 CPU. Likewise, data from the master is stored in variable memory in the S7-200 CPU and can be moved to other data areas.

The DP port of the EM 277 PROFIBUS–DP module can be attached to a DP master on the network and still communicate as an MPI slave with other master devices such as SIMATIC programming devices or S7-300/S7-400 CPUs on the same network. Figure A-21 shows a PROFIBUS network with a CPU 224 and an EM 277 PROFIBUS–DP module.

- ❑ The CPU 315–2 is the DP master and has been configured by a SIMATIC programming device with STEP 7 programming software.
- ❑ The CPU 224 is a DP slave owned by the CPU 315–2. The ET 200 I/O module is also a slave owned by the CPU 315–2.
- ❑ The S7-400 CPU is attached to the PROFIBUS network and is reading data from the CPU 224 by means of XGET instructions in the S7-400 CPU user program.

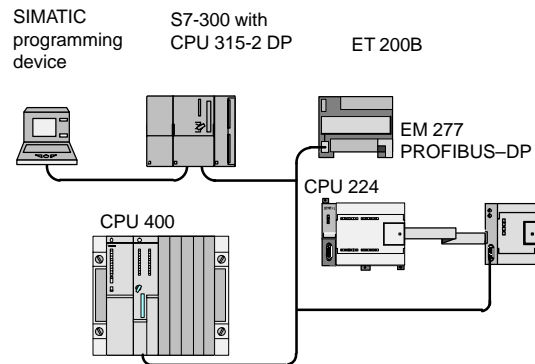

Figure A-21 EM 277 PROFIBUS–DP Module and CPU 224 on a PROFIBUS Network

A

Configuration

To use the EM 277 PROFIBUS–DP as a DP slave, you must set the station address of the DP port to match the address in the configuration of the master. The station address is set with the rotary switches on the EM 277 module. You must power cycle the CPU after you have made a switch change in order for the new slave address to take effect.

The master device exchanges data with each of its slaves by sending information from its output area to the slave's output buffer (called a "Receive mailbox"). The slave responds to the message from the master by returning an input buffer (called a "Send mailbox") which the master stores in an input area.

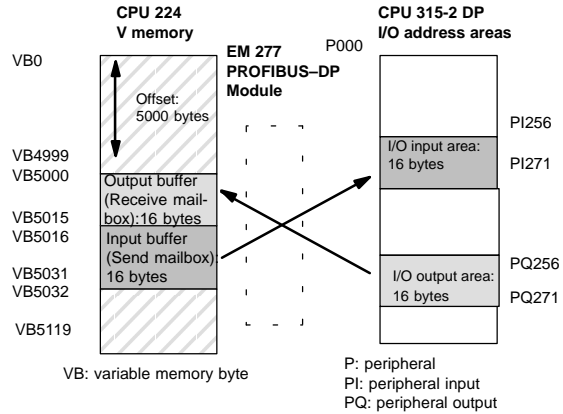

Figure A-22 V Memory and I/O Address Area

Figure A-22 shows an example of the V memory and I/O address area of a PROFIBUS–DP Master.

The EM 277 PROFIBUS–DP can be configured by the DP master to accept output data from the master and return input data to the master. The output and input data buffers reside in the variable memory (V memory) of the S7-200 CPU. When you configure the DP master, you define the byte location in V memory where the output data buffer should start as part of the parameter assignment information for the EM 277. You also define the I/O configuration as the amount of output data to be written to the S7-200 CPU and amount of input data to be returned from the S7-200 CPU. The EM 277 determines the size of the input and output buffers from the I/O configuration. The DP master writes the parameter assignment and I/O configuration information to the EM 277 PROFIBUS DP module. The EM 277 then transfers the V memory address and input and output data lengths to the S7-200 CPU.

Figure A-22 shows a memory model of the V memory in a CPU 224 and the I/O address areas of a DP master CPU. In this example, the DP master has defined an I/O configuration of 16 output bytes and 16 input bytes, and a V memory offset of 5000. The output buffer and input buffer lengths in the CPU 224 (determined from the I/O configuration) are both 16 bytes long. The output data buffer starts at V5000; the input buffer immediately follows the output buffer and begins at V5016. The output data (from the master) is placed in V memory at V5000. The input data (to the master) is taken from the V memory at V5016.



Tip

If you are working with a data unit (consistent data) of three bytes or data units greater than four bytes, you must use SFC14 to read the inputs of the DP slave and SFC15 to address the outputs of the DP slave. For more information, see the *System Software for S7-300 and S7-400 System and Standard Functions Reference Manual*.

Table A-38 lists the configurations that are supported by the EM 277 PROFIBUS–DP module. The default configuration for the EM 277 module is two words of input and two words of output.

Table A-38 EM 277 Configuration Options

Configuration	Inputs to Master	Outputs from Master	Data Consistency
1	1 word	1 word	Word Consistency
2	2 words	2 words	
3	4 words	4 words	
4	8 words	8 words	
5	16 words	16 words	
6	32 words	32 words	
7	8 words	2 words	
8	16 words	4 words	
9	32 words	8 words	
10	2 words	8 words	
11	4 words	16 words	
12	8 words	32 words	
13	2 bytes	2 bytes	Byte Consistency
14	8 bytes	8 bytes	
15	32 bytes	32 bytes	
16	64 bytes	64 bytes	
17	4 bytes	4 bytes	Buffer Consistency
18	8 bytes	8 bytes	
19	12 bytes	12 bytes	
20	16 bytes	16 bytes	

You can configure the location of the input and output buffers to be anywhere in the V memory of the S7-200 CPU. The default address for the input and output buffers is VB0. The location of the input and output buffers is part of the parameter assignment information that the master writes to the S7-200 CPU. You configure the master to recognize its slaves and to write the required parameters and I/O configuration to each of its slaves.

Use the following tools to configure the DP master:

- For SIMATIC S5 masters, use COM PROFIBUS Windows software
- For SIMATIC S7 masters, use STEP 7 programming software
- For SIMATIC 505 masters, use COM PROFIBUS and either TISOFT2 or SoftShop

For detailed information about using these configuration and programming software packages, refer to the manuals for these devices. For detailed information about the PROFIBUS network and its components, refer to the *ET 200 Distributed I/O System Manual*.

Data Consistency

PROFIBUS supports three types of data consistency:

- ❑ Byte consistency ensures that bytes are transferred as whole units.
- ❑ Word consistency ensures that word transfers cannot be interrupted by other processes in the CPU (the two bytes composing the word are always moved together and cannot be split). Use Word consistency if the data values being transferred are integers.
- ❑ Buffer consistency ensures that the entire buffer of data is transferred as a single unit, uninterrupted by any other process in the CPU. Buffer consistency should be used if the data values are double words or floating point values or when a group of values all relate to one calculation or item.

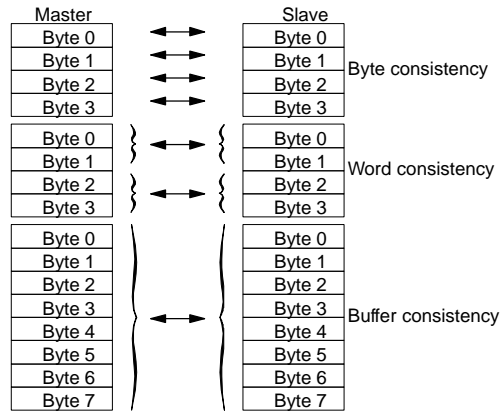

Figure A-23 Byte, Word, and Buffer Data Consistency

You set the data consistency as part of the I/O configuration in the master. The data consistency selection is written to the DP slave as part of the initialization of the slave. Both the DP master and the DP slave use the data consistency selection to be sure that data values (bytes, words, or buffers) are transferred uninterrupted within master and slave. The different types of consistency are shown in Figure A-23.

User Program Considerations

Once the EM 277 PROFIBUS–DP module has been successfully configured by a DP master, the EM 277 and the DP master enter data exchange mode. In data exchange mode, the master writes output data to the EM 277 PROFIBUS–DP module, the EM 277 module then responds with most current S7-200 CPU input data. The EM 277 module continuously updates its inputs from the S7-200 CPU in order to provide the most recent input data to the DP Master. The module then transfers the output data to the S7-200 CPU. The output data from the master is placed into V memory (the output buffer) starting at the address that the DP master supplied during initialization. The input data to the master is taken from the V memory locations (the input buffer) immediately following the output data.

The output data from the master must be moved by the user program in the S7-200 CPU from the output buffer to the data areas where it is to be used. Likewise, the input data to the master must be moved from the various data areas to the input buffer for transfer to the master.

Output data from the DP master is placed into V memory immediately after the user program portion of the scan has been executed. Input data (to the master) is copied from V memory to the EM 277 for transfer to the master at the same time.

Output data from the master is only written into V memory when there is new data available from the master.

Input data to the master are transmitted to the master on the next data exchange with the master.

The starting address of the data buffers in V memory and the size of the buffers must be known at the time the user program for the S7-200 CPU is created.

Status Information

There are 50 bytes of special memory (SM) allocated to each intelligent module based on its physical position. The module updates the SM locations corresponding to the modules' relative position to the CPU (with respect to other modules). If it is the first module, it updates SMB200 through SMB249. If it is the second module, it updates SMB250 through SMB299, and so on. See Table A-39.

Notice

The manner of assigning SM locations for Intelligent modules changed for Version 2.2 and later. If you are using a CPU prior to version 2.2, you should place all intelligent modules in slots adjacent to the CPU and before all non-intelligent modules to ensure compatibility.

Table A-39 Special Memory Bytes SMB200 to SMB549

Special Memory Bytes SMB200 to SMB549						
Intelligent Module in Slot 0	Intelligent Module in Slot 1	Intelligent Module in Slot 2	Intelligent Module in Slot 3	Intelligent Module in Slot 4	Intelligent Module in Slot 5	Intelligent Module in Slot 6
SMB200 to SMB249	SMB250 to SMB299	SMB300 to SMB349	SMB350 to SMB399	SMB400 to SMB449	SMB450 to SMB499	SMB500 to SMB549

These SM locations show default values if DP communications have not been established with a master. After a master has written parameters and I/O configuration to the EM 277 PROFIBUS–DP module, these SM locations show the configuration set by the DP master. You should check the protocol status byte (for example SMB224 for slot 0) to be sure that the EM 277 is currently in data exchange mode with the master before using the information in the SM locations shown in Table A-40, or data in the V memory buffer.



Tip

You cannot configure the EM 277 PROFIBUS–DP I/O buffer sizes or buffer location by writing to SM memory locations. Only the DP master can configure the EM 277 PROFIBUS–DP module for DP operation.

Table A-40 Special Memory Bytes for the EM 277 PROFIBUS–DP

Intelligent Module in Slot 0	...	Intelligent Module in Slot 6	Description																															
SMB200 to SMB215	...	SMB500 to SMB515	Module name (16 ASCII characters) "EM277 ProfibusDP"																															
SMB216 to SMB219	...	SMB516 to SMB519	S/W revision number (4 ASCII characters) xxxx																															
SMW220	...	SMW520	Error code 16#0000 No error 16#0001 No user power 16#0002 to 16#FFFF Reserved																															
SMB222	...	SMB522	DP slave module's station address as set by address switches (0 – 99 decimal)																															
SMB223	...	SMB523	Reserved																															
SMB224	...	SMB524	DP standard protocol status byte <div style="text-align: center;"> <table border="1" style="margin: auto;"> <tr> <td colspan="6" style="text-align: left;">MSB</td> <td colspan="2" style="text-align: right;">LSB</td> </tr> <tr> <td style="width: 20px;">0</td> <td style="width: 20px;">0</td> <td style="width: 20px;">0</td> <td style="width: 20px;">0</td> <td style="width: 20px;">0</td> <td style="width: 20px;">0</td> <td style="width: 20px;">S1</td> <td style="width: 20px;">S0</td> </tr> </table> </div> <table style="margin-left: auto; margin-right: auto;"> <tr> <td style="text-align: center;">S1</td> <td style="text-align: center;">S0</td> <td style="text-align: left;">DP Standard status byte description</td> </tr> <tr> <td style="text-align: center;">0</td> <td style="text-align: center;">0</td> <td>DP communications not initiated since power on</td> </tr> <tr> <td style="text-align: center;">0</td> <td style="text-align: center;">1</td> <td>Configuration/parameterization error detected</td> </tr> <tr> <td style="text-align: center;">1</td> <td style="text-align: center;">0</td> <td>Currently in data exchange mode</td> </tr> <tr> <td style="text-align: center;">1</td> <td style="text-align: center;">1</td> <td>Dropped out of data exchange mode</td> </tr> </table>	MSB						LSB		0	0	0	0	0	0	S1	S0	S1	S0	DP Standard status byte description	0	0	DP communications not initiated since power on	0	1	Configuration/parameterization error detected	1	0	Currently in data exchange mode	1	1	Dropped out of data exchange mode
MSB						LSB																												
0	0	0	0	0	0	S1	S0																											
S1	S0	DP Standard status byte description																																
0	0	DP communications not initiated since power on																																
0	1	Configuration/parameterization error detected																																
1	0	Currently in data exchange mode																																
1	1	Dropped out of data exchange mode																																
SMB225	...	SMB525	DP standard protocol – address of the slave's master (0 to 126)																															
SMW226	...	SMW526	DP standard protocol – V memory address of the output buffer as an offset from VB0.																															
SMB228	...	SMB528	DP standard protocol – number of bytes of output data																															
SMB229	...	SMB529	DP standard protocol – number of bytes of input data																															
SMB230 to SMB249	...	SMB530 to SMB549	Reserved – cleared on power up																															

Note: SM locations are updated each time the DP slave module accepts configuration/ parameterization information. These locations are updated even if a configuration/parameterization error is detected. The locations are cleared on each power up.

LED Status Indicators for the EM 277 PROFIBUS–DP

The EM 277 PROFIBUS–DP module has four status LEDs on the front panel to indicate the operational state of the DP port:

- After the S7-200 CPU is turned on, the DX MODE LED remains off as long as DP communications are not attempted.
- Once DP communications have been successfully initiated (the EM 277 PROFIBUS–DP module has entered data exchange mode with the master), the DX MODE LED turns green and remains on until data exchange mode is exited.
- If DP communications are lost, which forces the EM 277 module to exit data exchange mode, the DX MODE LED turns OFF and the DP ERROR LED turns red. This condition persists until the S7-200 CPU is powered off or data exchange is resumed.
- If there is an error in the I/O configuration or parameter information that the DP master is writing to the EM 277 module, the DP ERROR LED flashes red.
- If user 24 VDC is not provided, the POWER LED will be off.

Table A-41 summarizes the status indications signified by the EM 277 status LEDs.

Table A-41 EM 277 PROFIBUS–DP Module Status LEDs

LED	OFF	RED	FLASHING RED	GREEN
CPU FAULT	Module is good	Internal Module Failure	—	—
POWER	No 24 VDC User Power	—	—	24 VDC User Power Good
DP ERROR	No Error	Left Data Exchange Mode	Parameterization/ Configuration Error	—
DX MODE	Not in Data Exchange Mode	—	—	In Data Exchange Mode

Note: When the EM 277 PROFIBUS–DP module is used exclusively as an MPI slave, only the green Power LED is on.

Additional Configuration Features

The EM 277 PROFIBUS–DP module can be used as a communications interface to other MPI masters, whether or not it is being used as a PROFIBUS–DP slave. The module can provide a connection from the S7-300/400 to the S7-200 using the XGET/XPUT functions of the S7-300/400. STEP 7–Micro/WIN and a network card (such as the CP5611) using the MPI or PROFIBUS parameter set, an OP device or the TD 200 (Rel. 2.0 or greater, order number 6ES7 272–0AA20–0YA0) can be used to communicate with the S7-200 through the EM 277 PROFIBUS–DP module.

A maximum of six connections (six devices) in addition to the DP master can be connected to the EM 277 PROFIBUS–DP module. One connection is reserved for a programming device (PG) and one is reserved for an operator panel (OP). The other four connections can be used by any MPI master. In order for the EM 277 PROFIBUS–DP module to communicate with multiple masters, all masters must be operating at the same baud rate. See the Figure A-24 for one possible network configuration.

When the EM 277 PROFIBUS–DP module is used for MPI communications, the MPI master must use the station address of the module for all messages that are sent to the S7-200 to which the module is connected. MPI messages sent to the EM 277 PROFIBUS–DP module are passed on to the S7-200.

The EM 277 PROFIBUS–DP module is a slave module and cannot be used for communications between S7-200 PLCs using the NETR and NETW functions. The EM 277 PROFIBUS–DP module cannot be used for Freepoint communications.

A

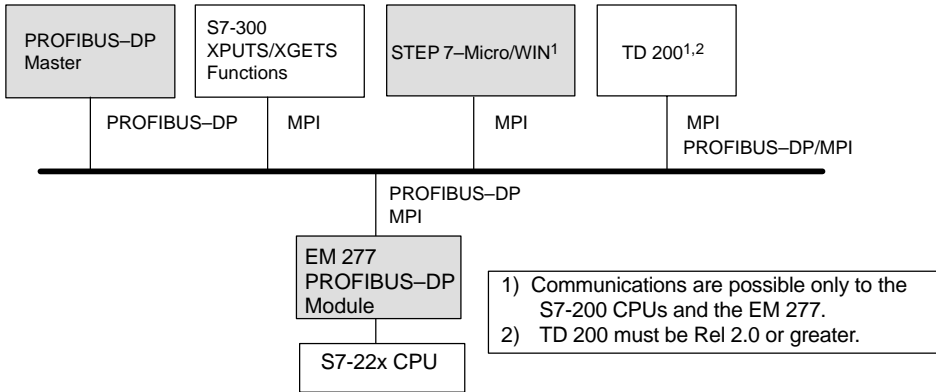

Figure A-24 PROFIBUS-DP/MPI Network

Device Database File: GSD

Different PROFIBUS devices have different performance characteristics. These characteristics differ with respect to functionality (for example, the number of I/O signals and diagnostic messages) or bus parameters, such as transmission speed and time monitoring. These parameters vary for each device type and vendor, and are usually documented in a technical manual. To help you achieve a simple configuration of PROFIBUS, the performance characteristics of a particular device are specified in an electronic data sheet called a device database file, or GSD file. Configuration tools based on GSD files allow simple integration of devices from different vendors in a single network.

The device database file provides a comprehensive description of the characteristics of a device in a precisely defined format. These GSD files are prepared by the vendor for each type of device and made available to the PROFIBUS user. The GSD file allows the configuration system to read in the characteristics of a PROFIBUS device and use this information when configuring the network.

The latest versions of the COM PROFIBUS or STEP 7 software include configuration files for the EM 277 PROFIBUS-DP Module. If your version of software does not include a configuration file for the EM 277, you can access the latest GSD file (SIEM089D.GSD) at website www.profibus.com.

If you are using a non-Siemens master device, refer to the documentation provided by the manufacturer on how to configure the master device by using the GSD file.



```

;=====
; GSD File for the EM 277 PROFIBUS-DP with a DPC31
; MLFB : 6ES7 277-0AA2.-0XA0
; DATE : 26-March-2001
;=====
#Profibus_DP
;General parameters
GSD_Revision = 1
Vendor_Name = "Siemens"
Model_Name = "EM 277 PROFIBUS-DP"
Revision = "V1.02"
Ident_Number = 0x089D
Protocol_Ident = 0
Station_Type = 0
FMS_supp = 0
Hardware_Release = "1.00"
Software_Release = "1.02"
9.6_supp = 1
19.2_supp = 1
45.45_supp = 1
93.75_supp = 1
187.5_supp = 1
500_supp = 1
1.5M_supp = 1
3M_supp = 1
6M_supp = 1
12M_supp = 1
MaxTsdr_9.6 = 60
MaxTsdr_19.2 = 60
MaxTsdr_45.45 = 250
MaxTsdr_93.75 = 60
MaxTsdr_187.5 = 60
MaxTsdr_500 = 100
MaxTsdr_1.5M = 150
MaxTsdr_3M = 250
MaxTsdr_6M = 450
MaxTsdr_12M = 800
Redundancy = 0
Repeater_Ctrl_Sig = 2
24V_Pins = 2

; Slave-Specification:
OrderNumber="6ES7 277-0AA2.-0XA0"
Periphery="SIMATIC S5"
Slave_Family=10@Tdf@SIMATIC

Freeze_Mode_supp = 1
Sync_Mode_supp = 1
Set_Slave_Add_Supp = 0
Auto_Baud_supp = 1
Min_Slave_Intervall = 1
Fail_Safe = 0
Max_Diag_Data_Len = 6
Modul_Offset = 0
Modular_Station = 1
Max_Module = 1
Max_Input_len = 128
Max_Output_len = 128
Max_Data_len = 256

; UserPrmData-Definition
ExtUserPrmData=1 "I/O Offset in the V-memory"
Unsigned16 0 0-10239
EndExtUserPrmData
; UserPrmData: Length and Preset:
User_Prm_Data_Len=3
User_Prm_Data= 0,0,0
Max_User_Prm_Data_Len=3
Ext_User_Prm_Data_Const(0)=0x00,0x00,0x00
Ext_User_Prm_Data_Ref(1)=1
;=====
; Continuation of GSD File
;=====
; Module Definition List
Module = "2 Bytes Out/ 2 Bytes In -" 0x31
EndModule
Module = "8 Bytes Out/ 8 Bytes In -" 0x37
EndModule
Module = "32 Bytes Out/ 32 Bytes In -"
0xC0,0x1F,0x1F
EndModule
Module = "64 Bytes Out/ 64 Bytes In -"
0xC0,0x3F,0x3F
EndModule
Module = "1 Word Out/ 1 Word In -" 0x70
EndModule
Module = "2 Word Out/ 2 Word In -" 0x71
EndModule
Module = "4 Word Out/ 4 Word In -" 0x73
EndModule
Module = "8 Word Out/ 8 Word In -" 0x77
EndModule
Module = "16 Word Out/ 16 Word In -" 0x7F
EndModule
Module = "32 Word Out/ 32 Word In -"
0xC0,0x5F,0x5F
EndModule
Module = "2 Word Out/ 8 Word In -"
0xC0,0x41,0x47
EndModule
Module = "4 Word Out/ 16 Word In -"
0xC0,0x43,0x4F
EndModule
Module = "8 Word Out/ 32 Word In -"
0xC0,0x47,0x5F
EndModule
Module = "8 Word Out/ 2 Word In -"
0xC0,0x47,0x41
EndModule
Module = "16 Word Out/ 4 Word In -"
0xC0,0x4F,0x43
EndModule
Module = "32 Word Out/ 8 Word In -"
0xC0,0x5F,0x47
EndModule
Module = "4 Byte buffer I/O -" 0xB3
EndModule
Module = "8 Byte buffer I/O -" 0xB7
EndModule
Module = "12 Byte buffer I/O -" 0xBB
EndModule
Module = "16 Byte buffer I/O -" 0xBF
EndModule

```

Figure A-25 Listing of the GSD File for the EM 277 PROFIBUS Module

Sample Program for DP Communications to a CPU

A sample program in Statement List for the PROFIBUS–DP module in slot 0 for a CPU that uses the DP port information in SM memory is shown below. The program determines the location of the DP buffers from SMW226 and the sizes of the buffers from SMB228 and SMB229. This information is used to copy the data in the DP output buffer to the process-image output register of the CPU. Similarly, the data in the process-image input register of the CPU are copied into the V memory input buffer.

Notice

The manner of assigning SM locations for Intelligent modules changed for Version 2.2 and later.

If you are using a CPU prior to version 2.2, you should place all intelligent modules in slots adjacent to the CPU and before all non-intelligent modules to ensure compatibility.

In the following sample program for a DP module in position 0, the DP configuration data in the SM memory area provides the configuration of the DP slave. The program uses the following data:

SMW220	DP Module Error Status
SMB224	DP Status
SMB225	Master Address
SMW226	V memory offset of outputs
SMB228	Number of bytes of output data
SMB229	Number of bytes of input data
VD1000	Output Data Pointer
VD1004	Input Data Pointer

Example of DP Communications to a CPU

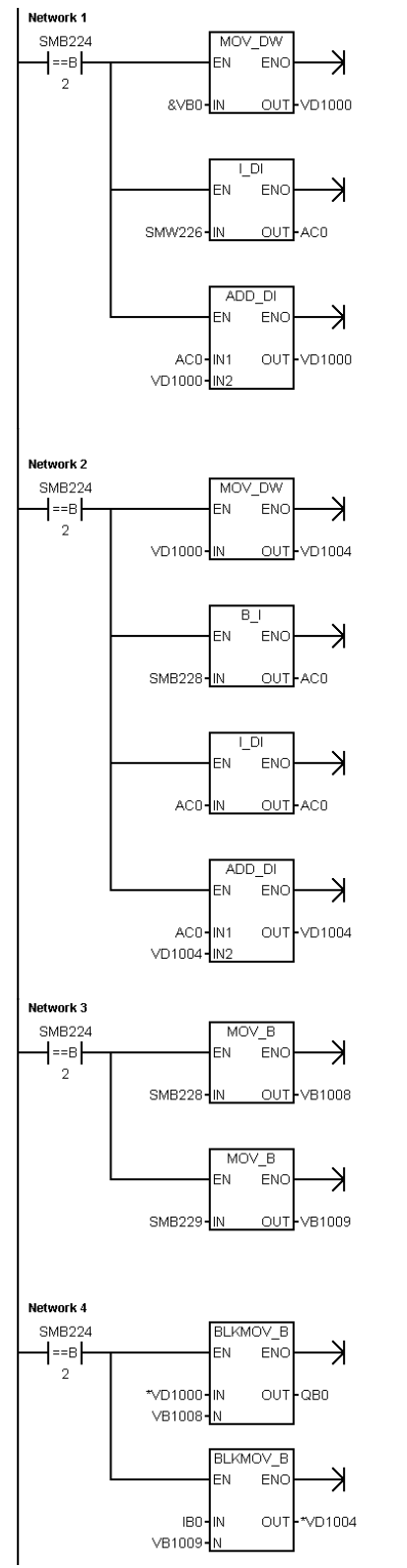

```

Network 1 //Calculate the Output data pointer. If in data exchange
//mode:
//1. Output buffer is an offset from VB0
//2. Convert Vmem offset to double integer
//3. Add to VB0 address to get output data pointer.

LDB= SMB224, 2
MOVD &VB0, VD1000
ITD SMW226, AC0
+D AC0, VD1000

Network 2 //Calculate the Input data pointer. If in data exchange
//mode:
//1. Copy the output data pointer
//2. Get the number of output bytes
//3. Add to output data pointer to get starting input data
// pointer.

LDB= SMB224, 2
MOVD VD1000, VD1004
BTI SMB228, AC0
ITD AC0, AC0
+D AC0, VD1004

Network 3 //Set amount of data to be copied. If in data exchange
//mode:
//1. Get number of output bytes to copy
//2. Get number of input bytes to copy

LDB= SMB224, 2
MOVB SMB228, VB1008
MOVB SMB229, VB1009

Network 4 //Transfer Master outputs to CPU outputs. Copy CPU
//inputs to the Master inputs. If in data exchange mode:
//1. Copy Master outputs to CPU outputs
//2. Copy CPU inputs to Master inputs

LDB= SMB224, 2
BMB *VD1000, QB0, VB1008
BMB IB0, *VD1004, VB1009
    
```

A

EM 241 Modem Module Specifications

Table A-42 EM 241 Modem Module Order Number

Order Number	Expansion Model	EM Inputs	EM Outputs	Removable Connector
6ES7 241-1AA22-0XA0	EM 241 Modem Module	–	8 ¹	No

¹ Eight Q outputs are used as logical controls of the modem function and do not directly control any external signals.

Table A-43 EM 241 Modem Module General Specifications

Order Number	Module Name and Description	Dimensions (mm) (W x H x D)	Weight	Dissipation	VDC Requirements	
					+5 VDC	+24 VDC
6ES7 241-1AA22-0XA0	EM 241 Modem Module	71.2 x 80 x 62	190 g	2.1 W	80 mA	70 mA

Table A-44 EM 241 Modem Module Specifications

General	6ES7 241-1AA22-0XA0
Telephone Connection	
Isolation (phone line to logic and field power)	1500 VAC (Galvanic)
Physical connection	RJ11 (6 position, 4 wire)
Modem standards	Bell 103, Bell 212, V.21, V.22, V.22 bis, V.23c, V.32, V.32 bis, V.34 (default)
Security features	Password Callback
Dialing	Pulse or Tone
Messaging Protocols	Numeric TAP (alphanumeric) UCP commands 1, 30, 51
Industrial Protocols	Modbus PPI
24 VDC Input Power Requirements	
Voltage range	20.4 to 28.8 VDC
Isolation (field power to logic)	500 VAC for 1 minute

The EM 241 Modem Module replaces the function of an external modem connected to the communications port of the CPU. With an EM 241 installed in your S7-200 system, all you need to communicate with your CPU from a remote location is a personal computer with an external modem and STEP 7-Micro/WIN.

See Chapter 7, Communicating over a Network, for information on configuring. See Chapter 10, Creating a Program for the Modem Module for programming and advanced features of the module.

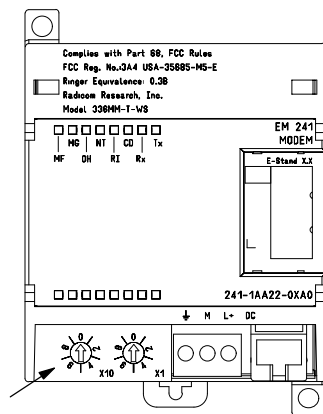

Country Code Switch

Figure A-26 EM 241 Modem Module Terminal Block Diagram

A

S7-200 CPUs that Support Intelligent Modules

The EM 241 Modem module is an intelligent expansion module designed to work with the S7-200 CPUs shown in Table A-45.

Table A-45 EM 241 Modem Module Compatibility with S7-200 CPUs

CPU	Description
CPU 222 Rel. 1.10 or greater	CPU 222 DC/DC/DC and CPU 222 AC/DC/Relay
CPU 224 Rel. 1.10 or greater	CPU 224 DC/DC/DC and CPU 224 AC/DC/Relay
CPU 226 Rel. 1.00 or greater	CPU 226 DC/DC/DC and CPU 226 AC/DC/Relay
CPU 226XM Rel. 1.00 or greater	CPU 226XM DC/DC/DC and CPU 226XM AC/DC/Relay

Installing the EM 241

Follow these steps to install the EM 241:

1. Snap the EM 241 on the DIN rail and plug in the ribbon cable.
2. Connect 24 VDC from the CPU sensor supply or external source, and connect the ground terminal to your system earth ground.
3. Plug the phone line into the RJ11 jack.
4. Set the country code switches according to Table A-46. You must set the switches before power is applied to the CPU for the correct country code to be read.
5. Power the CPU. The green MG (Module Good) light should come on.

Your EM 241 is now ready to communicate.

Table A-46 Country Codes Supported by the EM 241

Code	Country	Telecom Standard
01	Austria	CTR21
02	Belgium	CTR21
05	Canada	IC CS03
08	Denmark	CTR21
09	Finland	CTR21
10	France	CTR21
11	Germany	CTR21
12	Greece	CTR21
16	Ireland	CTR21
18	Italy	CTR21
22	Luxembourg	CTR21
25	Netherlands	CTR21
27	Norway	CTR21
30	Portugal	CTR21
34	Spain	CTR21
35	Sweden	CTR21
36	Switzerland	CTR21
38	U.K.	CTR21
39	U.S.A.	FCC Part 68

A

RJ11 Jack

Figure A-27 shows the details of the RJ11 Jack. You can use adaptors to other standard telephone connectors. Refer to your adaptor connector documentation for more information.

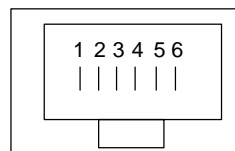

Pin	Description
3	Ring
4	Tip

Reverse connection is allowed.

Figure A-27 View of RJ11 Jack

Caution

Lightning surges or other unexpected high voltages on the telephone line can damage your EM 241 Modem Module.

Use a commercially available telephone line surge protector, such as are commonly sold for protection of personal computer modems. Surge protectors can be damaged as they protect your EM 241 Modem Module. Choose a surge protector with a positive indicator that shows it is functional.

Check your surge protector regularly to ensure that your EM 241 Modem Module continues to be protected.

EM 253 Position Module Specifications

Table A-47 EM 253 Position Module Order Number

Order Number	Expansion Model	EM Inputs	EM Outputs	Removable Connector
6ES7 253-1AA22-0XA0	EM 253 Position Module	–	8 ¹	Yes

¹ Eight Q outputs are used as logical controls of the motion function and do not directly control any external signals.

Table A-48 EM 253 Position Module General Specifications

Order Number	Module Name and Description	Dimensions (mm) (W x H x D)	Weight	Dissipation	VDC Requirements	
					+5 VDC	+24 VDC
6ES7 253-1AA22-0XA0	EM 253 Position Module	71.2 x 80 x 62	0.190 kg	2.5 W	190 mA	See below

Table A-49 EM 253 Position Module Specifications

General	6ES7 253-1AA22-0XA0
Input Features	
Number of inputs	5 points
Input type	Sink/Source (IEC Type 1 sink, except ZP)
Input Voltage	
Maximum Continuous permissible STP, RPS, LMT+, LMT– ZP	30 VDC 30 VDC at 20 mA, maximum
Surge (all inputs)	35 VDC for 0.5 sec.
Rated Value STP, RPS, LMT+, LMT– ZP	24 VDC at 4 mA, nominal 24 VDC at 15 mA, nominal
Logic "1" signal (minimum) STP, RPS, LMT+, LMT– ZP	15 VDC at 2.5 mA, minimum 3 VDC at 8.0 mA, minimum
Logic "0" signal (maximum) STP, RPS, LMT+, LMT– ZP	5 VDC at 1 mA, maximum 1 VDC at 1 mA, maximum
Isolation (field to logic)	
Optical Isolation (Galvanic)	500 VAC for 1 minute
Isolation groups of	1 point for STP, RPS, and ZP 2 points for LMT+ and LMT–
Input Delay Times	
STP, RPS, LMT+, LMT– ZP (countable pulse width)	0.2 ms to 12.8 ms, user selectable 2 μsec minimum
Connection of 2 Wire Proximity Sensor (Bero)	
Permissible leakage current	1 mA, maximum
Cable Length	
Unshielded STP, RPS, LMT+, LMT– ZP	30 meters Not recommended
Shielded STP, RPS, LMT+, LMT– ZP	100 meters 10 meters
Number of inputs on simultaneously	
55 Degrees C	5

A

Table A-49 EM 253 Position Module Specifications, continued

General	6ES7 253-1AA22-0XA0	
Output Features		
Number of integrated outputs	6 points (4 signals)	
Output type P0+, P0-, P1+, P1- P0, P1, DIS, CLR	RS422/485 driver Open drain	
Output voltage P0, P1, RS-422 drivers, differential output voltage Open circuit Into optocoupler diode with 200Ω series resistance 100Ω load 54Ω load P0, P1, DIS, CLR open drain recommended voltage, open circuit permissible voltage, open circuit Sink current On state resistance Off state leakage current, 30 VDC Internal Pull up resistor, output drain to T1	3.5 V typical 2.8 V minimum 1.5 V minimum 1.0 V minimum 5 VDC, available from module 30 VDC ¹ 50 mA maximum 15Ω maximum 10 μA maximum 3.3K Ω ²	
Output current Number of output groups Number of outputs ON (maximum) Leakage current per point P0, P1, DIS, CLR Overload Protection	1 6 10 μA maximum No	
Isolation (field to logic) Optical Isolation (Galvanic)	500 VAC for 1 minute	
Output delay DIS, CLR: Off to On / On to Off	30 μs, maximum	
Pulse Distortion P0, P1, outputs, RS-422 drivers, 100 Ω external load P0, P1 outputs, open drain, 5 V / 470 Ω external load	75 ns maximum 300 ns maximum	
Switching frequency P0+, P0-, P1+, P1-, P0 and P1	200 kHz	
Cable length Unshielded Shielded	Not recommended 10 meters	
Power Supply		
L+ supply voltage Logic supply output L+ supply current vs. 5 VDC load	11 to 30 VDC +5 VDC +/- 10%, 200 mA maximum	
Load current 0 mA (no load) 200 mA (rated load)	<u>12 VDC Input</u> 120 mA 300 mA	<u>24 VDC Input</u> 70 mA 130 mA
Isolation L+ power to logic L+ power to inputs L+ power to outputs	500 VAC for 1 minute 500 VAC for 1 minute None	
Reverse Polarity	L+ input and +5V output are diode-protected. Placing a positive voltage on any M terminal with respect to output point connections can result in potentially damaging current flow.	

¹ Operation of open drain outputs above 5 VDC may increase radio frequency emissions above permissible limits. Radio frequency containment measures may be required for your system or wiring.
² Depending on your pulse receiver and cable, an additional external pull up resistor may improve pulse signal quality and noise immunity.



S7-200 CPUs that Support Intelligent Modules

The EM 253 Position module is an intelligent expansion module designed to work with the S7-200 CPUs shown in Table A-50.

Table A-50 EM 253 Position Module Compatibility with S7-200 CPUs

CPU	Description
CPU 222 Rel. 1.10 or greater	CPU 222 DC/DC/DC and CPU 222 AC/DC/Relay
CPU 224 Rel. 1.10 or greater	CPU 224 DC/DC/DC and CPU 224 AC/DC/Relay
CPU 226 Rel. 1.00 or greater	CPU 226 DC/DC/DC and CPU 226 AC/DC/Relay
CPU 226XM Rel. 1.00 or greater	CPU 226XM DC/DC/DC and CPU 226XM AC/DC/Relay

EM 253 Position Module Status LEDs

The Status LEDs for the Position Modules are shown in Table A-51.

Table A-51 Position Module Status LEDs

Local I/O	LED	Color	Function Description
-	MF	Red	Illuminated when module detects a fatal error
-	MG	Green	Illuminated when there is no module fault, and flashes at 1 Hz rate when a configuration error is detected
-	PWR	Green	Illuminated when 24 VDC is supplied on the L+ and M terminals of the module
Input	STP	Green	Illuminated when the stop input is on
Input	RPS	Green	Illuminated when the reference point switch input is on
Input	ZP	Green	Illuminated when the zero pulse input is on
Input	LMT-	Green	Illuminated when the negative limit input is on
Input	LMT +	Green	Illuminated when the positive limit input is on
Output	P0	Green	Illuminated when the P0 output is pulsing
Output	P1	Green	Illuminated when the P1 output is pulsing or when this output indicates positive motion
Output	DIS	Green	Illuminated when the DIS output is active
Output	CLR	Green	Illuminated when the clear deviation counter output is active

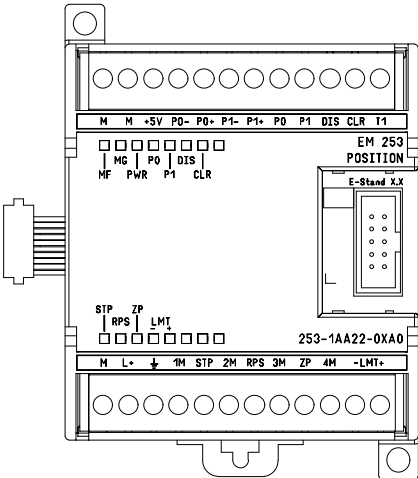

Figure A-28 EM 253 Position Module



Wiring Diagrams

In the following schematic figures, the terminals are not in order. See Figure A-28 for terminal arrangement.

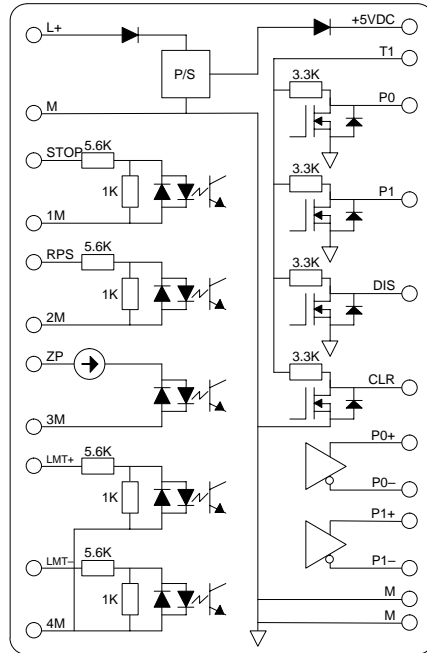
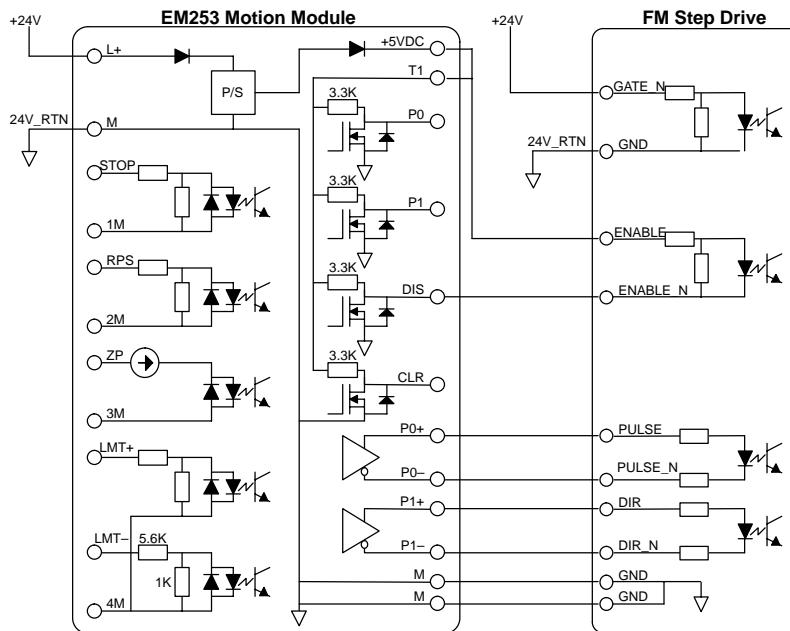

Figure A-29 Internal Schematic for the Inputs and Outputs of the EM 253 Position Module



Terminals are not in order.
See Figure A-28 for terminal arrangement.

Figure A-30 Connecting an EM 253 Position Module to a SIMATIC FM Step Drive

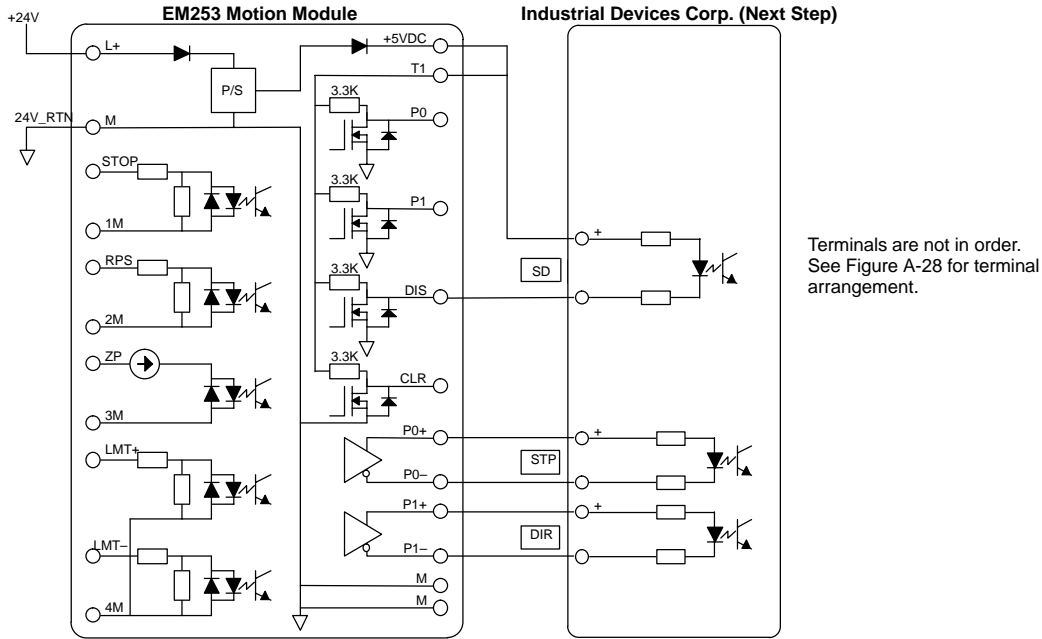

Figure A-31 Connecting an EM 253 Position Module to a Industrial Devices Corp. (Next Step)

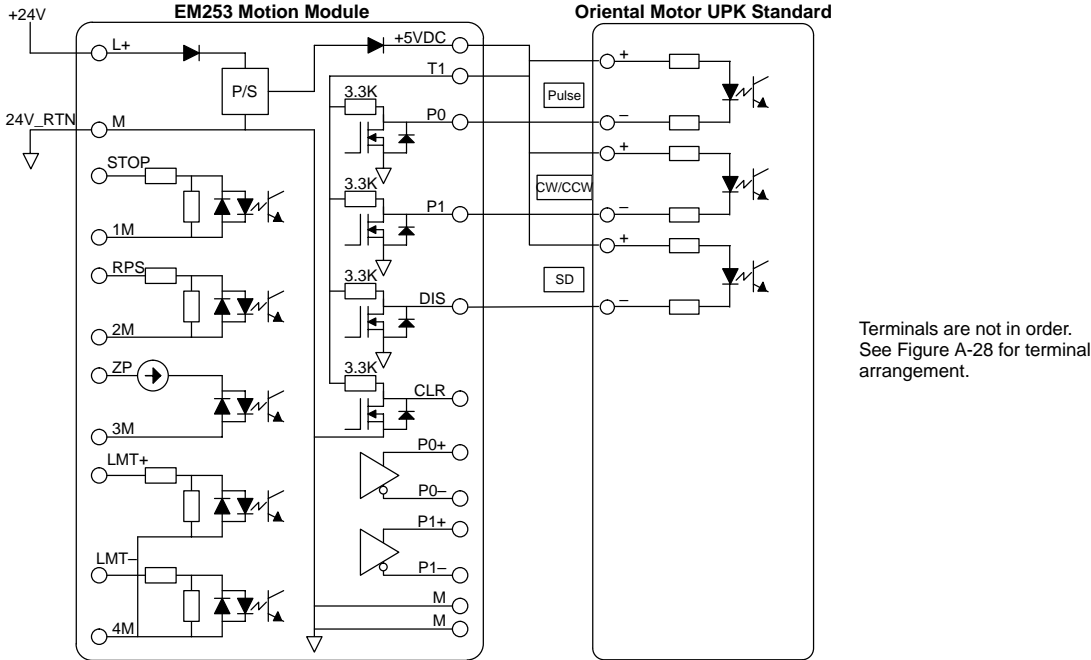

Figure A-32 Connecting an EM 253 Position Module to an Oriental Motor UPK Standard

A

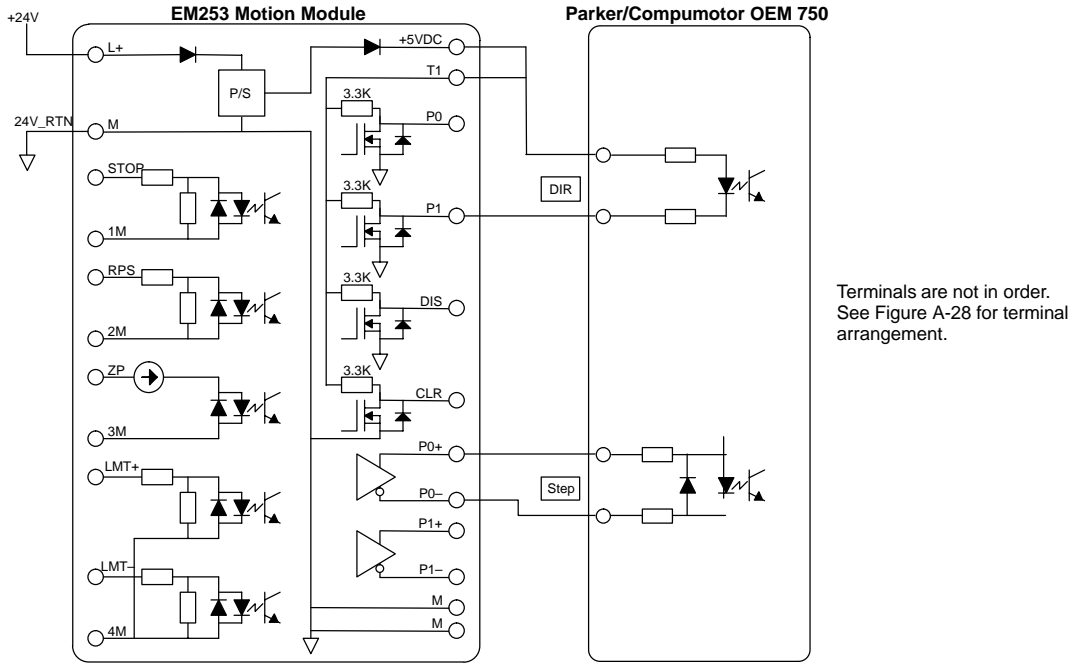

Figure A-33 Connecting an EM 253 Position Module to a Parker/Compumotor OEM 750

AS–Interface (CP 243–2) Module Specifications

Table A-52 AS-Interface (CP 243–2) Module Order Number

Order Number	Expansion Model	EM Inputs	EM Outputs	Removable Connector
6GK7 243–2AX01–0XA0	AS–Interface (CP 243–2) Module	8 Digital and 8 Analog	8 Digital and 8 Analog	Yes

Table A-53 AS-Interface (CP 243–2) Module General Specifications

Order Number	Module Name and Description	Dimensions (mm) (W x H x D)	Weight	Dissipation	+5 VDC	VDC Requirements From AS–Interface
6GK7 243–2AX01–0XA0	AS–Interface (CP 243–2) Module	71 x 80 x 62	approx. 250 g	3.7 W	220 mA	100 mA

Table A-54 AS-Interface (CP 243–2) Module Specifications

General	6GK7 243–2AX01–0XA0
Cycle time	5 ms with 31 slaves 10 ms with 62 AS–I slaves using the extended addressing mode
Configuration	Set button on the front panel, or use the total configuration command (refer to the description of the AS–I commands in the <i>CP 243–2 AS–I Interface Master</i> manual)
AS–I master profiles supported	M1e
Attachment to the AS–I cable	Via an S7-200 terminal block. Permitted current loading from terminal 1 to 3 or from terminal 2 to 4 maximum 3 A.
Address range	One digital module with 8 digital inputs and 8 digital outputs, and One analog module with 8 analog inputs and 8 analog outputs

Features

You can operate up to two AS–Interface modules on the S7-200 at the same time, significantly increasing the number of available digital and analog inputs/outputs (maximum 124 digital input/124 digital output on AS–Interface per CP). Setup times are reduced because of the ability to configure at the touch of a button. LEDs reduce downtime in the event of an error by displaying status of the CP and of all connected slaves, and by monitoring AS–Interface main voltage.

The AS–Interface Module has the following features:

- Supports analog modules
- Supports all master functions and allows connections for up to 62 AS–Interface slaves
- LEDs in the front plate display operating status and availability of connected slaves.
- LEDs in the front plate display errors (including AS–Interface voltage error, configuration error)
- Two terminals allow direct connection of the AS–Interface cable.
- Two buttons display the status information of the slaves, switch operating mode, and adopt the existing configuration as the SET configuration.

Operation

In the process image of the S7-200, the AS-Interface Module occupies a digital input byte (status byte), a digital output byte (control byte), 8 analog input and 8 analog output words. The AS-Interface Module uses two logical module positions. You can use the status and the control byte to set the mode of the AS-Interface Module using a user program. Depending on its mode, the AS-Interface stores either the I/O data of the AS-Interface slave, diagnostics values, or enables master calls (for example, changing a slave address) in the analog address area of the S7-200.

All the connected AS-Interface slaves can be configured at the touch of a button. Further configuration of the CP is not necessary.



Caution

When you use the AS-Interface Module, you must disable analog filtering in the CPU.

If analog filtering is not disabled in the CPU, the digital point data will be destroyed, and error conditions will not be returned as bit values in the analog word.

Ensure that analog filtering in the CPU is disabled.

Functions

The CP 243-2 is the AS-Interface master for the M1e master class, which means that it supports all the specified functions. This makes it possible to operate up to 31 digital slaves on the AS-Interface by means of double address assignment (A-B). The CP 243-2 can be set to two different modes:

- Standard mode: access to the I/O data of the AS-Interface slave
- Extended mode: master calls (for example, write parameters) or diagnostic value request

Connections

The AS-Interface Module has the following connections:

- Two connections to the AS-Interface Module cable (bridged internally)
- One connection for functional ground

The terminals are located under the cover of the front panel as shown in Figure A-34.

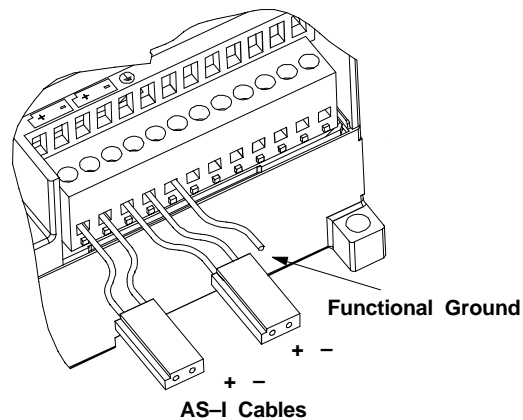

Figure A-34 Connecting the AS-Interface Module Cable

Caution

The load capacity of the AS-Interface Module contacts is a maximum of 3 A. If this value is exceeded on the AS-Interface Module cable, the AS-Interface must not be looped into the AS-I cable, but must be connected by a separate cable (in this case, only one pair of terminals of the AS-Interface Module is used). The AS-Interface must be connected to the grounding conductor via the ground terminal.



Tip

The AS-Interface Module has a connection for functional ground. This connector should be connected to the PE conductor with as little resistance as possible.

Additional Information

For more information about the CP 243-2 AS-Interface Master, refer to the *SIMATIC NET CP 243-2 AS-Interface Master manual*.

Optional Cartridges

Cartridge	Description	Order Number
Memory cartridge	Memory cartridge storage: Program, Data, and Configuration	6ES7 291-8GE20-0XA0
Real-Time Clock with battery	Clock cartridge accuracy: 2 minutes/month at 25°C, 7 minutes/month at 0°C to 55°C	6ES7 297-1AA20-0XA0
Battery cartridge	Battery cartridge (data retention time): 200 days, typical	6ES7 291-8BA20-0XA0

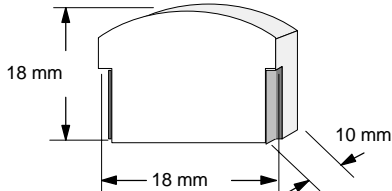
General Features		Dimensions
Battery Size Type	3 V, 30 mA hour, Renata CR 1025 9.9 mm x 2.5 mm Lithium < 0.6 g	

The Memory cartridge stores the complete program and data block for all CPUs (CPU 221, CPU 222, CPU 224, CPU 226 and CPU 226XM).

I/O Expansion Cable

General Features (6ES7 290-6AA20-0XA0)	
Cable length	0.8 m
Weight	25 g
Connector type	10 pin ribbon

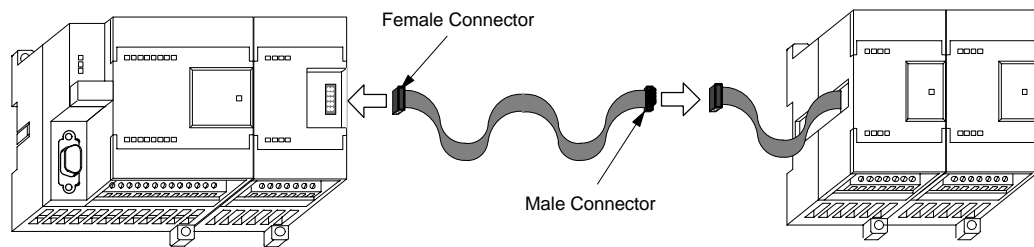

Figure A-35 Typical Installation of the I/O Expansion Cable



Tip

Only one expansion cable is allowed in a CPU/expansion module chain.

PC/PPI Cable

PC/PPI Cable (6ES7 901-3BF21-0XA0)	
General Characteristics	
Supply voltage	14.4 to 28.8 VDC
Supply current at 24 V nominal supply	50 mA RMS max.
Direction change delay: RS-232 start bit edge received to RS-485 start bit edge transmitted	1.2 μ S max.
Direction change delay: RS-232 stop bit edge received to RS-485 transmission disabled	1.4 character times max. (1.4 x 11/ baud) = 1.6 ms at 9600 baud
Propagation delay	4 μ S max., RS-485 to RS-232, 1.2 μ S max., RS-232 to RS-485
Isolation (RS-485 to RS-232)	500 VDC
RS-485 Side Electrical Characteristics	
Common mode voltage range	-7 V to +12 V, 1 second, 3 V RMS continuous
Receiver input impedance	5.4K Ω min., including termination
Termination/bias	10K Ω to +5V on B, PROFIBUS pin 3 10K Ω to GND on A, PROFIBUS pin 8
Receiver threshold/sensitivity	+/- 0.2 V, 60 mV typical hysteresis
Transmitter differential output voltage	2 V min. at $R_L = 100 \Omega$, 1.5 V min. at $R_L = 54 \Omega$
RS-232 Side Electrical Characteristics	
Receiver input impedance	3K Ω min., minimum
Receiver threshold/sensitivity	0.8 V min. low, 2.4 V max. high, 0.5 V typical hysteresis
Transmitter output voltage	+/- 5 V min. at $R_L = 3K \Omega$

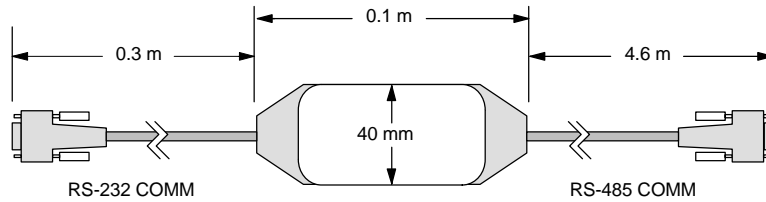

SIEMENS		Isolated PC/PPI Cable	
PPI 1 0	Dipswitch #	123	4
	115.2-38.4K	000	1= 10 BIT
	19.2	001	0= 11 BIT
	9.6K	010	5 1= DTE
	2.4K	100	0= DCE
	1.2K	101	6 1= RTS for XMT
			0= RTS Always

Figure A-36 PC/PPI Cable Dimensions

Table A-55 Switch Selections on the PC/PPI Cable

Baud Rate	Switches 1,2,3*	Modem Operation	Switch 4*	DCE/DTE Selection	Switch 5*	RTS Selection for DTE	Switch 6*
115200 – 38400	000	11-bit modem	0	DCE	0	RTS always active	0
19200	001	10-bit modem	1	DTE	1	RTS active when PLC transmits	1
9600	010						
4800	011						
2400	100						
1200	101						
600	110						

* Switch : 1 = Up; 0 = Down

Table A-56 Pin-outs for the RS-485 to RS-232 DCE Connector

RS-485 Connector Pin-out		RS-232 DCE Connector Pin-out	
Pin Number	Signal Description	Pin Number	Signal Description
1	Ground (RS-485 logic ground)	1	Data Carrier Detect (DCD) (not used)
2	24 V Return (RS-485 logic ground)	2	Receive Data (RD) (output from PC/PPI cable)
3	Signal B (Rx/D/TxD+)	3	Transmit Data (TD) (input to PC/PPI cable)
4	RTS (TTL level)	4	Data Terminal Ready (DTR)(not used)
5	Ground (RS-485 logic ground)	5	Ground (RS-232 logic ground)
6	No connect	6	Data Set Ready (DSR) (not used)
7	24 V Supply	7	Request To Send (RTS) (not used)
8	Signal A (Rx/D/TxD-)	8	Clear To Send (CTS) (not used)
9	Protocol select	9	Ring Indicator (RI) (not used)

Table A-57 Pin-outs for RS-485 to RS-232 DTE Connector

RS-485 Connector Pin-out		RS-232 DTE Connector Pin-out ¹	
Pin Number	Signal Description	Pin Number	Signal Description
1	Ground (RS-485 logic ground)	1	Data Carrier Detect (DCD) (not used)
2	24 V Return (RS-485 logic ground)	2	Receive Data (RD) (input to PC/PPI cable)
3	Signal B (Rx/D/TxD+)	3	Transmit Data (TD) (output from PC/PPI cable)
4	RTS (TTL level)	4	Data Terminal Ready (DTR) (not used)
5	Ground (RS-485 logic ground)	5	Ground (RS-232 logic ground)
6	No connect	6	Data Set Ready (DSR) (not used)
7	24 V Supply	7	Request To Send (RTS) (output from PC/PPI cable) (switch selectable)
8	Signal A (Rx/D/TxD-)	8	Clear To Send (CTS) (not used)
9	Protocol select	9	Ring Indicator (RI) (not used)

¹ A conversion from female to male, and a conversion from 9-pin to 25-pin is required for modems

A

Input Simulators

Order Number	8 Position Simulator 6ES7 274-1XF00-0XA0	14 Position Simulator 6ES7 274-1XH00-0XA0	24 Position Simulator 6ES7 274-1XK00-0XA0
Size (L x W x D)	61 x 36 x 22 mm	91 x 36 x 22 mm	147 x 36 x 25 mm
Weight	0.02 Kg	0.03 Kg	0.04 Kg
Points	8	14	24

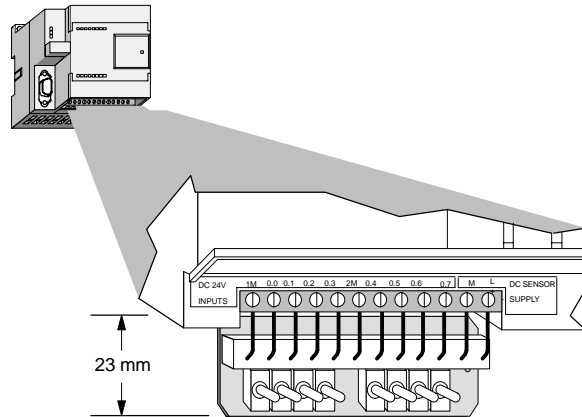

Figure A-37 Installation of the Input Simulator



Caution

These input simulators are not approved for use in Class I DIV 2 or Class I Zone 2 hazardous locations. The switches present a potential spark hazard.

Do not use input simulators in Class I DIV 2 or Class I Zone 2 hazardous locations.

Calculating a Power Budget



The S7-200 CPU has an internal power supply that provides power for the CPU itself, for any expansion modules, and for other 24 VDC user power requirements. Use the following information as a guide for determining how much power (or current) the S7-200 CPU can provide for your configuration.

Power Requirements

Each S7-200 CPU supplies both 5 VDC and 24 VDC power:

- Each CPU has a 24 VDC sensor supply that can supply 24 VDC for local input points or for relay coils on the expansion modules. If the power requirement for 24 VDC exceeds the power budget of the CPU, you can add an external 24 VDC power supply to provide 24 VDC to the expansion modules. You must manually connect the 24 VDC supply to the input points or relay coils.
- The CPU also provides 5 VDC power for the expansion modules when an expansion module is connected. If the 5 VDC power requirements for expansion modules exceeds the power budget of the CPU, you must remove expansion modules until the requirement is within the power budget.

The specifications in Appendix A provide information about the power budgets of the CPUs and the power requirements of the expansion modules.



Warning

Connecting an external 24 VDC power supply in parallel with the S7-200 DC Sensor Supply can result in a conflict between the two supplies as each seeks to establish its own preferred output voltage level.

The result of this conflict can be shortened lifetime or immediate failure of one or both power supplies, with consequent unpredictable operation of the PLC system. Unpredictable operation could result in death or serious injury to personnel, and/or damage to equipment.

The S7-200 DC Sensor Supply and any external power supply should provide power to different points. A single connection of the commons is allowed.

Calculating a Sample Power Requirement

Table B-1 shows a sample calculation of the power requirements for an S7-200 that includes the following:

- S7-200 CPU 224 AC/DC/Relay
- 3 each EM 223 8 DC In/8 Relay Out
- 1 each EM 221 8 DC In

This installation has a total of 46 inputs and 34 outputs.

The S7-200 CPU in this example provides sufficient 5 VDC current for the expansion modules, but does not provide enough 24 VDC current from the sensor supply for all of the inputs and expansion relay coils. The I/O requires 400 mA and the S7-200 CPU provides only 280 mA. This installation requires an additional source of at least 120 mA at 24 VDC power to operate all the included 24 VDC inputs and outputs.

Table B-1 Power Budget Calculations for a Sample Configuration

CPU Power Budget	5 VDC	24 VDC
CPU 224 AC/DC/Relay	660 mA	280 mA
minus		
System Requirements	5 VDC	24 VDC
CPU 224, 14 inputs		14 * 4 mA = 56 mA
3 EM 223, 5 V power required	3 * 80 mA = 240 mA	
1 EM 221, 5V power required	1 * 30 mA = 30 mA	
3 EM 223, 8 inputs each		3 * 8 * 4 mA = 96 mA
3 EM 223, 8 relay coils each		3 * 8 * 9 mA = 216 mA
1 EM 221, 8 inputs each		8 * 4 mA = 32 mA
Total Requirements	270 mA	400 mA
equals		
Current Balance	5 VDC	24 VDC
Current Balance Total	390 mA	[120 mA]

Calculating Your Power Requirement

Use the table below to determine how much power (or current) the S7-200 CPU can provide for your configuration. Refer to Appendix A for the power budgets of your CPU model and the power requirements of your expansion modules.

Power Budget	5 VDC	24 VDC

minus

System Requirements	5 VDC	24 VDC
Total Requirements		

equals

Current Balance	5 VDC	24 VDC
Current Balance Total		



B

Error Codes

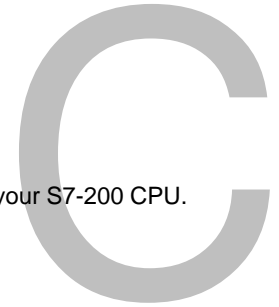

The information about error codes is provided to help you identify problems with your S7-200 CPU.

In This Chapter

Fatal Error Codes and Messages	404
Run-Time Programming Problems	405
Compile Rule Violations	406

Fatal Error Codes and Messages

Fatal errors cause the S7-200 to stop the execution of your program. Depending on the severity of the error, a fatal error can render the S7-200 incapable of performing any or all functions. The objective for handling fatal errors is to bring the S7-200 to a safe state from which the S7-200 can respond to interrogations about the existing error conditions.

The S7-200 performs the following tasks when a fatal error is detected:

- Changes to STOP mode
- Turns on both the System Fault LED and the Stop LED
- Turns off the outputs

The S7-200 remains in this condition until the fatal error is corrected. To view the error codes, select the **PLC > Information** menu command from the main menu bar. Table C-1 provides a list with descriptions for the fatal error codes that can be read from the S7-200.

Table C-1 Fatal Error Codes and Messages Read from the S7-200

Error Code	Description
0000	No fatal errors present
0001	User program checksum error
0002	Compiled ladder program checksum error
0003	Scan watchdog time-out error
0004	Internal EEPROM failed
0005	Internal EEPROM checksum error on user program
0006	Internal EEPROM checksum error on configuration (SDB0) parameters
0007	Internal EEPROM checksum error on force data
0008	Internal EEPROM checksum error on default output table values
0009	Internal EEPROM checksum error on user data, DB1
000A	Memory cartridge failed
000B	Memory cartridge checksum error on user program.
000C	Memory cartridge checksum error on configuration (SDB0) parameters
000D	Memory cartridge checksum error on force data
000E	Memory cartridge checksum error on default output table values
000F	Memory cartridge checksum error on user data, DB1
0010	Internal software error
0011 ¹	Compare contact indirect addressing error
0012 ¹	Compare contact illegal floating point value
0013	Memory cartridge is blank, or the program is not understood by this S7-200
0014 ¹	Compare contact range error

¹ The compare contact errors are the only errors that generate both fatal and non-fatal error conditions. The reason for the generation of the non-fatal error condition is to save the program address of the error.

Run-Time Programming Problems

Your program can create non-fatal error conditions (such as addressing errors) during the normal execution of the program. In this case, the S7-200 generates a non-fatal run-time error code. Table C-2 lists the descriptions of the non-fatal error codes.

Table C-2 Run-Time Programming Problems

Error Code	Description
0000	No fatal errors present; no error
0001	HSC box enabled before executing HDEF box
0002	Conflicting assignment of input interrupt to a point already assigned to a HSC
0003	Conflicting assignment of inputs to an HSC already assigned to input interrupt or other HSC
0004	Attempted execution of ENI, DISI, SPA, or HDEF instructions in an interrupt routine
0005	Attempted execution of a second HSC/PLS with the same number before completing the first (HSC/PLS in an interrupt routine conflicts with HSC/PLS in main program)
0006	Indirect addressing error
0007	TODW (Time-of-Day Write) or TODR (Time-of-Day Read) data error
0008	Maximum user subroutine nesting level exceeded
0009	Simultaneous execution of XMT/RCV instructions on Port 0
000A	Attempt to redefine a HSC by executing another HDEF instruction for the same HSC
000B	Simultaneous execution of XMT/RCV instructions on Port 1
000C	Clock cartridge not present for access by TODR, TODW, or communications
000D	Attempt to redefine pulse output while it is active
000E	Number of PTO profile segment was set to 0
000F	Illegal numeric value in compare contact instruction
0091	Range error (with address information): check the operand ranges
0092	Error in count field of an instruction (with count information): verify the maximum count size
0094	Range error writing to non-volatile memory with address information
009A	Attempt to switch to Freeport mode while in a user interrupt
009B	Illegal index (string operation in which a starting position value of 0 is specified)

Compile Rule Violations

When you download a program, the S7-200 compiles the program. If the S7-200 detects that the program violates a compile rule (such as an illegal instruction), the S7-200 aborts the download and generates a non-fatal, compile-rule error code. Table C-3 lists the descriptions of the error codes that are generated by violations of the compile rules.

Table C-3 Compile Rule Violations

Error Code	Compile Errors (Non-Fatal)
0080	Program too large to compile; reduce program size
0081	Stack underflow; split network into multiple networks.
0082	Illegal instruction; check instruction mnemonics.
0083	Missing MEND or instruction not allowed in main program: add MEND instruction, or remove incorrect instruction.
0084	Reserved
0085	Missing FOR; add FOR instruction or delete NEXT instruction.
0086	Missing NEXT; add NEXT instruction or delete FOR instruction.
0087	Missing label (LBL, INT, SBR); add the appropriate label.
0088	Missing RET or instruction not allowed in a subroutine: add RET to the end of the subroutine or remove incorrect instruction.
0089	Missing RETI or instruction not allowed in an interrupt routine: add RETI to the end of the interrupt routine or remove incorrect instruction.
008A	Reserved
008B	Illegal JMP to or from an SCR segment
008C	Duplicate label (LBL, INT, SBR); rename one of the labels.
008D	Illegal label (LBL, INT, SBR); ensure the number of labels allowed was not exceeded.
0090	Illegal parameter; verify the allowed parameters for the instruction.
0091	Range error (with address information); check the operand ranges.
0092	Error in the count field of an instruction (with count information); verify the maximum count size.
0093	FOR/NEXT nesting level exceeded.
0095	Missing LSCR instruction (Load SCR)
0096	Missing SCRE instruction (SCR End) or disallowed instruction before the SCRE instruction
0097	User program contains both unnumbered and numbered EV/ED instructions
0098	Illegal edit in RUN mode (edit attempted on program with unnumbered EV/ED instructions)
0099	Too many hidden program segments (HIDE instructions)
009B	Illegal index (string operation in which a starting position value of 0 is specified)
009C	Maximum instruction length exceeded

Special Memory (SM) Bits



Special memory bits provide a variety of status and control functions, and also serve as a means of communicating information between the S7-200 and your program. Special memory bits can be used as bits, bytes, words, or double words.

In This Chapter

SMB0: Status Bits	408
SMB1: Status Bits	408
SMB2: Freeport Receive Character	409
SMB3: Freeport Parity Error	409
SMB4: Queue Overflow	409
SMB5: I/O Status	410
SMB6: CPU ID Register	410
SMB7: Reserved	410
SMB8 to SMB21: I/O Module ID and Error Registers	411
SMW22 to SMW26: Scan Times	412
SMB28 and SMB29: Analog Adjustment	412
SMB30 and SMB130: Freeport Control Registers	412
SMB31 and SMW32: Permanent Memory (EEPROM) Write Control	413
SMB34 and SMB35: Time Interval Registers for Timed Interrupts	413
SMB36 to SMB65: HSC0, HSC1, and HSC2 Register	413
SMB66 to SMB85: PTO/PWM Registers	415
SMB86 to SMB94, and SMB186 to SMB194: Receive Message Control	416
SMW98: Errors on the Expansion I/O Bus	417
SMB130: Freeport Control Register (see SMB30)	417
SMB131 to SMB165: HSC3, HSC4, and HSC5 Register	417
SMB166 to SMB185: PTO0, PTO1 Profile Definition Table	418
SMB186 to SMB194: Receive Message Control (see SMB86 to SMB94)	418
SMB200 to SMB549: Intelligent Module Status	419

SMB0: Status Bits

As described in Table D-1, SMB0 contains eight status bits that are updated by the S7-200 at the end of each scan cycle.

Table D-1 Special Memory Byte SMB0 (SM0.0 to SM0.7)

SM Bits	Description (Read Only)
SM0.0	This bit is always on.
SM0.1	This bit is on for the first scan cycle. One use is to call an initialization subroutine.
SM0.2	This bit is turned on for one scan cycle if retentive data was lost. This bit can be used as either an error memory bit or as a mechanism to invoke a special startup sequence.
SM0.3	This bit is turned on for one scan cycle when RUN mode is entered from a power-up condition. This bit can be used to provide machine warm-up time before starting an operation.
SM0.4	This bit provides a clock pulse that is on for 30 seconds and off for 30 seconds, for a duty cycle time of 1 minute. It provides an easy-to-use delay, or a 1-minute clock pulse.
SM0.5	This bit provides a clock pulse that is on for 0.5 seconds and then off for 0.5 seconds, for a duty cycle time of 1 second. It provides an easy-to-use delay or a 1-second clock pulse.
SM0.6	This bit is a scan cycle clock which is on for one scan cycle and then off for the next scan cycle. This bit can be used as a scan counter input.
SM0.7	This bit reflects the position of the Mode switch (off is TERM position, and on is RUN position). If you use this bit to enable Freeport mode when the switch is in the RUN position, normal communications with the programming device can be enabled by switching to the TERM position.

SMB1: Status Bits

As described in Table D-2, SMB1 contains various potential error indicators. These bits are set and reset by instructions at execution time.

Table D-2 Special Memory Byte SMB1 (SM1.0 to SM1.7)

SM Bits	Description (Read Only)
SM1.0	This bit is turned on by the execution of certain instructions when the result of the operation is zero.
SM1.1	This bit is turned on by the execution of certain instructions either when an overflow results or when an illegal numeric value is detected.
SM1.2	This bit is turned on when a negative result is produced by a math operation.
SM1.3	This bit is turned on when division by zero is attempted.
SM1.4	This bit is turned on when the Add to Table instruction attempts to overfill the table.
SM1.5	This bit is turned on when either LIFO or FIFO instructions attempt to read from an empty table.
SM1.6	This bit is turned on when an attempt to convert a non-BCD value to binary is made.
SM1.7	This bit is turned on when an ASCII value cannot be converted to a valid hexadecimal value.

SMB2: Freeport Receive Character

SMB2 is the Freeport receive character buffer. As described in Table D-3, each character received while in Freeport mode is placed in this location for easy access from the ladder logic program.



Tip

SMB2 and SMB3 are shared between Port 0 and Port 1. When the reception of a character on Port 0 results in the execution of the interrupt routine attached to that event (interrupt event 8), SMB2 contains the character received on Port 0, and SMB3 contains the parity status of that character. When the reception of a character on Port 1 results in the execution of the interrupt routine attached to that event (interrupt event 25), SMB2 contains the character received on Port 1 and SMB3 contains the parity status of that character.

Table D-3 Special Memory Byte SMB2

SM Byte	Description (Read Only)
SMB2	This byte contains each character that is received from Port 0 or Port 1 during Freeport communications.

SMB3: Freeport Parity Error

SMB3 is used for Freeport mode and contains a parity error bit that is set when a parity error is detected on a received character. As shown in Table D-4, SM3.0 turns on when a parity error is detected. Use this bit to discard the message.

Table D-4 Special Memory Byte SMB3 (SM3.0 to SM3.7)

SM Bits	Description (Read Only)
SM3.0	Parity error from Port 0 or Port 1 (0 = no error; 1 = error was detected)
SM3.1 to SM3.7	Reserved

SMB4: Queue Overflow

As described in Table D-5, SMB4 contains the interrupt queue overflow bits, a status indicator showing whether interrupts are enabled or disabled, and a transmitter-idle memory bit. The queue overflow bits indicate either that interrupts are happening at a rate greater than can be processed, or that interrupts were disabled with the global interrupt disable instruction.

Table D-5 Special Memory Byte SMB4 (SM4.0 to SM4.7)

SM Bits	Description (Read Only)
SM4.0 ¹	This bit is turned on when the communications interrupt queue has overflowed.
SM4.1 ¹	This bit is turned on when the input interrupt queue has overflowed.
SM4.2 ¹	This bit is turned on when the timed interrupt queue has overflowed.
SM4.3	This bit is turned on when a run-time programming problem is detected.
SM4.4	This bit reflects the global interrupt enable state. It is turned on when interrupts are enabled.
SM4.5	This bit is turned on when the transmitter is idle (Port 0).
SM4.6	This bit is turned on when the transmitter is idle (Port 1).
SM4.7	This bit is turned on when something is forced.

¹ Use status bits 4.0, 4.1, and 4.2 only in an interrupt routine. These status bits are reset when the queue is emptied, and control is returned to the main program.

SMB5: I/O Status

As described in Table D-6, SMB5 contains status bits about error conditions that were detected in the I/O system. These bits provide an overview of the I/O errors detected.

Table D-6 Special Memory Byte SMB5 (SM5.0 to SM5.7)

SM Bits	Description (Read Only)
SM5.0	This bit is turned on if any I/O errors are present.
SM5.1	This bit is turned on if too many digital I/O points have been connected to the I/O bus.
SM5.2	This bit is turned on if too many analog I/O points have been connected to the I/O bus.
SM5.3	This bit is turned on if too many intelligent I/O modules have been connected to the I/O bus.
SM5.4 to SM5.7	Reserved.

SMB6: CPU ID Register

As described in Table D-7, SMB6 is the identification register for the S7-200 CPU. SM6.4 to SM6.7 identify the type of S7-200 CPU. SM6.0 to SM6.3 are reserved for future use.

Table D-7 Special Memory Byte SMB6

SM Bits	Description (Read Only)								
Format	<div style="display: flex; align-items: center; justify-content: center;"> <div style="text-align: center; margin-right: 10px;">MSB 7</div> <table border="1" style="border-collapse: collapse; text-align: center;"> <tr> <td style="width: 15px;">x</td> <td style="width: 15px;">x</td> <td style="width: 15px;">x</td> <td style="width: 15px;">x</td> <td style="width: 15px;">r</td> <td style="width: 15px;">r</td> <td style="width: 15px;">r</td> <td style="width: 15px;">r</td> </tr> </table> <div style="text-align: center; margin-left: 10px;">LSB 0</div> <div style="margin-left: 20px;">CPU ID register</div> </div>	x	x	x	x	r	r	r	r
x	x	x	x	r	r	r	r		
SM6.0 to SM6.3	Reserved								
SM6.4 to SM6.7	xxxx = 0000 = CPU 222 0010 = CPU 224 0110 = CPU 221 1001 = CPU 226/CPU 226XM								

SMB7: Reserved

SMB7 is reserved for future use.

SMW22 to SMW26: Scan Times

As described in Table D-9, SMW22, SMW24, and SMW26 provide scan time information: minimum scan time, maximum scan time, and last scan time in milliseconds.

Table D-9 Special Memory Words SMW22 to SMW26

SM Word	Description (Read Only)
SMW22	Scan time of the last scan cycle in milliseconds
SMW24	Minimum scan time in milliseconds recorded since entering the RUN mode
SMW26	Maximum scan time in milliseconds recorded since entering the RUN mode

SMB28 and SMB29: Analog Adjustment

As described in Table D-10, SMB28 holds the digital value that represents the position of analog adjustment 0. SMB29 holds the digital value that represents the position of analog adjustment 1.

Table D-10 Special Memory Bytes SMB28 and SMB29

SM Byte	Description (Read Only)
SMB28	This byte stores the value entered with analog adjustment 0. This value is updated once per scan in STOP/RUN.
SMB29	This byte stores the value entered with analog adjustment 1. This value is updated once per scan in STOP/RUN.

SMB30 and SMB130: Freepoint Control Registers

SMB30 controls the Freepoint communications for port 0; SMB130 controls the Freepoint communications for port 1. You can read and write to SMB30 and SMB130. As described in Table D-11, these bytes configure the respective communications ports for Freepoint operation and provide selection of either Freepoint or system protocol support.

Table D-11 Special Memory Byte SMB30

Port 0	Port 1	Description
Format of SMB30	Format of SMB130	Freepoint mode control byte <div style="display: flex; justify-content: space-between; align-items: center;"> MSB 7 LSB 0 </div> <div style="display: flex; justify-content: center; align-items: center; border: 1px solid black; padding: 2px;"> p p d b b b m m </div>
SM30.0 and SM30.1	SM130.0 and SM130.1	mm: Protocol selection 00 =Point-to-Point Interface protocol (PPI/slave mode) 01 =Freepoint protocol 10 =PPI/master mode 11 =Reserved (defaults to PPI/slave mode) Note: When you select code mm = 10 (PPI master), the S7-200 will become a master on the network and allow the NETR and NETW instructions to be executed. Bits 2 through 7 are ignored in PPI modes.
SM30.2 to SM30.4	SM130.2 to SM130.4	bbb: Freepoint Baud rate 000 =38,400 baud 100 =2,400 baud 001 =19,200 baud 101 =1,200 baud 010 =9,600 baud 110 =115,200 baud 011 =4,800 baud 111 =57,600 baud
SM30.5	SM130.5	d: Data bits per character 0 =8 bits per character 1 =7 bits per character
SM30.6 and SM30.7	SM130.6 and SM130.7	pp: Parity select 00 =no parity 10 =odd parity 01 =even parity 11 =odd parity

SMB31 and SMW32: Permanent Memory (EEPROM) Write Control

You can save a value stored in V memory to permanent memory (EEPROM) under the control of your program. To do this, load the address of the location to be saved in SMW32. Then, load SMB31 with the command to save the value. Once you have loaded the command to save the value, you do not change the value in V memory until the S7-200 resets SM31.7, indicating that the save operation is complete.

At the end of each scan, the S7-200 checks to see if a command to save a value to permanent memory was issued. If the command was issued, the specified value is saved to permanent memory.

As described in Table D-12, SMB31 defines the size of the data to be saved to permanent memory and provides the command that initiates a save operation. SMW32 stores the starting address in V memory for the data to be saved to permanent memory.

Table D-12 Special Memory Byte SMB31 and Special Memory Word SMW32

SM Byte	Description										
Format	<div style="display: flex; justify-content: space-between;"> <div style="text-align: center;"> <p>SMB31: Software command</p> <p>MSB 7</p> <table border="1" style="margin: auto;"> <tr> <td style="padding: 2px;">c</td> <td style="padding: 2px;">0</td> <td style="padding: 2px;">0</td> <td style="padding: 2px;">0</td> <td style="padding: 2px;">0</td> <td style="padding: 2px;">0</td> <td style="padding: 2px;">0</td> <td style="padding: 2px;">s</td> <td style="padding: 2px;">s</td> </tr> </table> </div> <div style="text-align: center;"> <p>LSB 0</p> </div> </div> <div style="display: flex; justify-content: space-between;"> <div style="text-align: center;"> <p>SMW32: V memory address</p> <p>MSB 15</p> <table border="1" style="margin: auto; width: 100%;"> <tr> <td style="text-align: center; padding: 2px;">V memory address</td> </tr> </table> </div> <div style="text-align: center;"> <p>LSB 0</p> </div> </div>	c	0	0	0	0	0	0	s	s	V memory address
c	0	0	0	0	0	0	s	s			
V memory address											
SM31.0 and SM31.1	ss: Size of the data 00 =byte 10 =word 01 =byte 11 =double word										
SM31.7	c: Save to EEPROM 0 =No request for a save operation to be performed 1 =User program requests to save data The S7-200 resets this bit after each save operation.										
SMW32	The V memory address for the data to be saved is stored in SMW32. This value is entered as an offset from V0. When a save operation is executed, the value in this V memory address is saved to the corresponding V memory location in the permanent memory (EEPROM).										

SMB34 and SMB35: Time Interval Registers for Timed Interrupts

As described in Table D-13, SMB34 specifies the time interval for timed interrupt 0, and SMB35 specifies the time interval for timed interrupt 1. You can specify the time interval (in 1-ms increments) from 1 ms to 255 ms. The time-interval value is captured by the S7-200 at the time the corresponding timed interrupt event is attached to an interrupt routine. To change the time interval, you must reattach the timed interrupt event to the same or to a different interrupt routine. You can terminate the timed interrupt event by detaching the event.

Table D-13 Special Memory Bytes SMB34 and SMB35

SM Byte	Description
SMB34	This byte specifies the time interval (in 1-ms increments from 1 ms to 255 ms) for timed interrupt 0.
SMB35	This byte specifies the time interval (in 1-ms increments from 1 ms to 255 ms) for timed interrupt 1.

SMB36 to SMB65: HSC0, HSC1, and HSC2 Register

As described in Table D-14, SMB36 through SM65 are used to monitor and control the operation of high-speed counters HSC0, HSC1, and HSC2.

Table D-14 Special Memory Bytes SMB36 to SMD62

SM Byte	Description
SM36.0 to SM36.4	Reserved
SM36.5	HSC0 current counting direction status bit: 1 = counting up
SM36.6	HSC0 current value equals preset value status bit: 1 = equal
SM36.7	HSC0 current value is greater than preset value status bit: 1 = greater than
SM37.0	Active level control bit for Reset: 0= Reset is active high, 1 = Reset is active low
SM37.1	Reserved
SM37.2	Counting rate selection for quadrature counters: 0 = 4x counting rate; 1 = 1 x counting rate
SM37.3	HSC0 direction control bit: 1 = count up
SM37.4	HSC0 update the direction: 1 = update direction
SM37.5	HSC0 update the preset value: 1 = write new preset value to HSC0 preset
SM37.6	HSC0 update the current value: 1 = write new current value to HSC0 current
SM37.7	HSC0 enable bit: 1 = enable
SMD38	HSC0 new current value
SMD42	HSC0 new preset value
SM46.0 to SM46.4	Reserved
SM46.5	HSC1 current counting direction status bit: 1 = counting up
SM46.6	HSC1 current value equals preset value status bit: 1 = equal
SM46.7	HSC1 current value is greater than preset value status bit: 1 = greater than
SM47.0	HSC1 active level control bit for reset: 0 = active high, 1 = active low
SM47.1	HSC1 active level control bit for start: 0 = active high, 1 = active low
SM47.2	HSC1 quadrature counter rate selection: 0 = 4x rate, 1 = 1x rate
SM47.3	HSC1 direction control bit: 1 = count up
SM47.4	HSC1 update the direction: 1 = update direction
SM47.5	HSC1 update the preset value: 1 = write new preset value to HSC1 preset
SM47.6	HSC1 update the current value: 1 = write new current value to HSC1 current
SM47.7	HSC1 enable bit: 1 = enable
SMD48	HSC1 new current value
SMD52	HSC1 new preset value
SM56.0 to SM56.4	Reserved
SM56.5	HSC2 current counting direction status bit: 1 = counting up
SM56.6	HSC2 current value equals preset value status bit: 1 = equal
SM56.7	HSC2 current value is greater than preset value status bit: 1 = greater than
SM57.0	HSC2 active level control bit for reset: 0 = active high, 1 = active low
SM57.1	HSC2 active level control bit for start: 0 = active high, 1 = active low
SM57.2	HSC2 quadrature counter rate selection: 0 = 4x rate, 1 = 1x rate
SM57.3	HSC2 direction control bit: 1 = count up
SM57.4	HSC2 update the direction: 1 = update direction
SM57.5	HSC2 update the preset value: 1 = write new preset value to HSC2 preset
SM57.6	HSC2 update the current value: 1 = write new current value to HSC2 current
SM57.7	HSC2 enable bit: 1 = enable
SMD58	HSC2 new current value
SMD62	HSC2 new preset value

SMB66 to SMB85: PTO/PWM Registers

As described in Table D-15, SMB66 through SMB85 are used to monitor and control the pulse train output and pulse width modulation functions. See the information on pulse output high-speed output instructions in Chapter 6 for a complete description of these bits.

Table D-15 Special Memory Bytes SMB66 to SMB85

SM Byte	Description
SM66.0 to SM66.3	Reserved
SM66.4	PTO0 profile aborted: 0 = no error, 1 = aborted due to a delta calculation error
SM66.5	PTO0 profile aborted: 0 = not aborted by user command, 1 = aborted by user command
SM66.6	PTO0 pipeline overflow (cleared by the system when using external profiles, otherwise must be reset by user): 0 = no overflow, 1 = pipeline overflow
SM66.7	PTO0 idle bit: 0 = PTO in progress, 1 = PTO idle
SM67.0	PTO0/PWM0 update the cycle time value: 1 = write new cycle time
SM67.1	PWM0 update the pulse width value: 1 = write new pulse width
SM67.2	PTO0 update the pulse count value: 1 = write new pulse count
SM67.3	PTO0/PWM0 time base: 0 = 1 μ s/tick, 1 = 1 ms/tick
SM67.4	Update PWM0 synchronously: 0 = asynchronous update, 1 = synchronous update
SM67.5	PTO0 operation: 0 = single segment operation (cycle time and pulse count stored in SM memory), 1 = multiple segment operation (profile table stored in V memory)
SM67.6	PTO0/PWM0 mode select: 0 = PTO, 1 = PWM
SM67.7	PTO0/PWM0 enable bit: 1 = enable
SMW68	PTO0/PWM0 cycle time value (2 to 65,535 units of time base);
SMW70	PWM0 pulse width value (0 to 65,535 units of the time base);
SMD72	PTO0 pulse count value (1 to $2^{32}-1$);
SM76.0 to SM76.3	Reserved
SM76.4	PTO1 profile aborted: 0 = no error, 1 = aborted because of delta calculation error
SM76.5	PTO1 profile aborted: 0 = not aborted by user command, 1 = aborted by user command
SM76.6	PTO1 pipeline overflow (cleared by the system when using external profiles, otherwise must be reset by the user): 0 = no overflow, 1 = pipeline overflow
SM76.7	PTO1 idle bit: 0 = PTO in progress, 1 = PTO idle
SM77.0	PTO1/PWM1 update the cycle time value: 1 = write new cycle time
SM77.1	PWM1 update the pulse width value: 1 = write new pulse width
SM77.2	PTO1 update the pulse count value: 1 = write new pulse count
SM77.3	PTO1/PWM1 time base: 0 = 1 μ s/tick, 1 = 1 ms/tick
SM77.4	Update PWM1 synchronously: 0 = asynchronous update, 1 = synchronous update
SM77.5	PTO1 operation: 0 = single segment operation (cycle time and pulse count stored in SM memory), 1 = multiple segment operation (profile table stored in V memory)
SM77.6	PTO1/PWM1 mode select: 0 = PTO, 1 = PWM
SM77.7	PTO1/PWM1 enable bit: 1 = enable
SMW78	PTO1/PWM1 cycle time value (2 to 65,535 units of the time base);
SMW80	PWM1 pulse width value (0 to 65,535 units of the time base);
SMD82	PTO1 pulse count value (1 to $2^{32}-1$);

SMB86 to SMB94, and SMB186 to SMB194: Receive Message Control

As described in Table D-16, SMB86 through SMB94 and SMB186 through SMB194 are used to control and read the status of the Receive Message instruction.

Table D-16 Special Memory Bytes SMB86 to SMB94, and SMB186 to SMB194

Port 0	Port 1	Description																			
SMB86	SMB186	Receive Message status byte <table style="margin-left: 20px; border-collapse: collapse;"> <tr> <td style="text-align: right; padding-right: 5px;">MSB</td> <td style="text-align: center;">7</td> <td colspan="6"></td> <td style="text-align: left; padding-left: 5px;">LSB</td> </tr> <tr> <td></td> <td></td> <td style="border: 1px solid black; text-align: center;">n</td> <td style="border: 1px solid black; text-align: center;">r</td> <td style="border: 1px solid black; text-align: center;">e</td> <td style="border: 1px solid black; text-align: center;">0</td> <td style="border: 1px solid black; text-align: center;">0</td> <td style="border: 1px solid black; text-align: center;">t</td> <td style="border: 1px solid black; text-align: center;">c</td> <td style="border: 1px solid black; text-align: center;">p</td> </tr> </table> <p>n: 1 = Receive message terminated by user disable command r: 1 = Receive message terminated: error in input parameters or missing start or end condition e: 1 = End character received t: 1 = Receive message terminated: timer expired c: 1 = Receive message terminated: maximum character count achieved p: 1 = Receive message terminated because of a parity error</p>	MSB	7							LSB			n	r	e	0	0	t	c	p
MSB	7							LSB													
		n	r	e	0	0	t	c	p												
SMB87	SMB187	Receive Message control byte <table style="margin-left: 20px; border-collapse: collapse;"> <tr> <td style="text-align: right; padding-right: 5px;">MSB</td> <td style="text-align: center;">7</td> <td colspan="6"></td> <td style="text-align: left; padding-left: 5px;">LSB</td> </tr> <tr> <td></td> <td></td> <td style="border: 1px solid black; text-align: center;">en</td> <td style="border: 1px solid black; text-align: center;">sc</td> <td style="border: 1px solid black; text-align: center;">ec</td> <td style="border: 1px solid black; text-align: center;">il</td> <td style="border: 1px solid black; text-align: center;">c/m</td> <td style="border: 1px solid black; text-align: center;">tmr</td> <td style="border: 1px solid black; text-align: center;">bk</td> <td style="border: 1px solid black; text-align: center;">0</td> </tr> </table> <p>en: 0 =Receive Message function is disabled. 1 =Receive Message function is enabled. The enable/disable receive message bit is checked each time the RCV instruction is executed. sc: 0 =Ignore SMB88 or SMB188. 1 =Use the value of SMB88 or SMB188 to detect start of message. ec: 0 =Ignore SMB89 or SMB189. 1 =Use the value of SMB89 or SMB189 to detect end of message. il: 0 =Ignore SMW90 or SMW190. 1 =Use the value of SMW90 or SMW190 to detect an idle line condition. c/m: 0 =Timer is an inter-character timer. 1 =Timer is a message timer. tmr: 0 =Ignore SMW92 or SMW192. 1 =Terminate receive if the time period in SMW92 or SMW192 is exceeded. bk: 0 =Ignore break conditions. 1 =Use break condition as start of message detection.</p>	MSB	7							LSB			en	sc	ec	il	c/m	tmr	bk	0
MSB	7							LSB													
		en	sc	ec	il	c/m	tmr	bk	0												
SMB88	SMB188	Start of message character																			
SMB89	SMB189	End of message character																			
SMW90	SMW190	Idle line time period given in milliseconds. The first character received after idle line time has expired is the start of a new message.																			
SMW92	SMW192	Inter-character/message timer time-out value (in milliseconds). If the time period is exceeded, the receive message is terminated.																			
SMB94	SMB194	Maximum number of characters to be received (1 to 255 bytes). Note: This range must be set to the expected maximum buffer size, even if the character count message termination is not used.																			

SMW98: Errors on the Expansion I/O Bus

As described in Table D-17, SMW98 gives you information about the number of errors on the expansion I/O bus.

Table D-17 Special Memory Bytes SMW98

SM Byte	Description
SMW98	This location is incremented each time a parity error is detected on the expansion I/O bus. It is cleared upon power up, and can be cleared by the user.

SMB130: Freepoint Control Register (see SMB30)

Refer to Table D-11.

SMB131 to SMB165: HSC3, HSC4, and HSC5 Register

As described in Table D-18, SMB131 through SMB165 are used to monitor and control the operation of high-speed counters HSC3, HSC4, and HSC5.

Table D-18 Special Memory Bytes SMB131 to SMB165

SM Byte	Description
SMB131 to SMB135	Reserved
SM136.0 to SM136.4	Reserved
SM136.5	HSC3 current counting direction status bit: 1 = counting up
SM136.6	HSC3 current value equals preset value status bit: 1 = equal
SM136.7	HSC3 current value is greater than preset value status bit: 1 = greater than
SM137.0 to SM137.2	Reserved
SM137.3	HSC3 direction control bit: 1 = count up
SM137.4	HSC3 update direction: 1 = update direction
SM137.5	HSC3 update preset value: 1 = write new preset value to HSC3 preset
SM137.6	HSC3 update current value: 1 = write new current value to HSC3 current
SM137.7	HSC3 enable bit: 1 = enable
SMD138	HSC3 new current value
SMD142	HSC3 new preset value
SM146.0 to SM146.4	Reserved
SM146.5	HSC4 current counting direction status bit: 1 = counting up
SM146.6	HSC4 current value equals preset value status bit: 1 = equal
SM146.7	HSC4 current value is greater than preset value status bit: 1 = greater than
SM147.0	Active level control bit for Reset: 0 = Reset is active high, 1 = Reset is active low
SM147.1	Reserved
SM147.2	Counting rate selection for quadrature counters: 0 = 4x counting rate, 1 = 1x counting rate
SM147.3	HSC4 direction control bit: 1 = count up
SM147.4	HSC4 update direction: 1 = update direction
SM147.5	HSC4 update preset value: 1 = write new preset value to HSC4 preset
SM147.6	HSC4 update current value: 1 = write new current value to HSC4 current
SM147.7	HSC4 enable bit: 1 = enable
SMD148	HSC4 new current value
SMD152	HSC4 new preset value

Table D-18 Special Memory Bytes SMB131 to SMB165, continued

SM Byte	Description
SM156.0 to SM156.4	Reserved
SM156.5	HSC5 current counting direction status bit: 1 = counting up
SM156.6	HSC5 current value equals preset value status bit: 1 = equal
SM156.7	HSC5 current value is greater than preset value status bit: 1 = greater than
SM157.0 to SM157.2	Reserved
SM157.3	HSC5 direction control bit: 1 = count up
SM157.4	HSC5 update direction: 1 = update direction
SM157.5	HSC5 update preset value: 1 = write new preset value to HSC5 preset
SM157.6	HSC5 update current value: 1 = write new current value to HSC5 current
SM157.7	HSC5 enable bit: 1 = enable
SMD158	HSC5 new current value
SMD162	HSC5 new preset value

SMB166 to SMB185: PTO0, PTO1 Profile Definition Table

As described in Table D-19, SMB166 through SMB185 are used to show the number of active profile steps and the address of the profile table in V memory.

Table D-19 Special Memory Bytes SMB166 to SMB185

SM Byte	Description
SMB166	Current entry number of the active profile step for PTO0
SMB167	Reserved
SMD168	V memory address of the profile table for PTO0 given as an offset from V0.
SMB170 to SMB175	Reserved
SMB176	Current entry number of the active profile step for PTO1
SMB177	Reserved
SMD178	V memory address of the profile table for PTO1 given as an offset from V0.
SMB180 to SMB185	Reserved

SMB186 to SMB194: Receive Message Control (see SMB86 to SMB94)

Refer to Table D-16.

SMB200 to SMB549: Intelligent Module Status

As shown in Table D-20, SMB200 through SMB549 are reserved for information provided by intelligent expansion modules, such as the EM 277 PROFIBUS–DP module. For information about how your module uses SMB200 through SMB549, refer to Appendix A for the specifications of your specific module.

The manner of assigning SM locations for Intelligent modules changed for Version 2.2 and later.

For an S7-200 CPU with firmware prior to version 1.2, you must install the intelligent module next to the CPU in order to ensure compatibility.

Table D-20 Special Memory Bytes SMB200 to SMB549

Special Memory Bytes SMB200 to SMB549							
Intelligent Module in Slot 0	Intelligent Module in Slot 1	Intelligent Module in Slot 2	Intelligent Module in Slot 3	Intelligent Module in Slot 4	Intelligent Module in Slot 5	Intelligent Module in Slot 6	Description
SMB200 to SMB215	SMB250 to SMB265	SMB300 to SMB315	SMB350 to SMB365	SMB400 to SMB415	SMB450 to SMB465	SMB500 to SMB515	Module name (16 ASCII characters)
SMB216 to SMB219	SMB266 to SMB269	SMB316 to SMB319	SMB366 to SMB369	SMB416 to SMB419	SMB466 to SMB469	SMB516 to SMB519	S/W revision number (4 ASCII characters)
SMW220	SMW270	SMW320	SMW370	SMW420	SMW470	SMW520	Error code
SMB222 to SMB249	SMB272 to SMB299	SMB322 to SMB349	SMB372 to SMB399	SMB422 to SMB449	SMB472 to SMB499	SMB522 to SMB549	Information specific to the particular module type

D

S7-200 Order Numbers

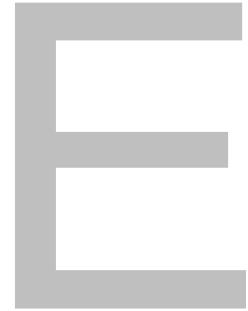

CPU s	Order Number
CPU 221 DC/DC/DC 6 Inputs/4 Outputs	6ES7 211-0AA22-0XB0
CPU 221 AC/DC/Relay 6 Inputs/4 Relays	6ES7 211-0BA22-0XB0
CPU 222 DC/DC/DC 8 Inputs/6 Outputs	6ES7 212-1AB22-0XB0
CPU 222 AC/DC/Relay 8 Inputs/6 Relays	6ES7 212-1BB22-0XB0
CPU 224 DC/DC/DC 14 Inputs/10 Outputs	6ES7 214-1AD22-0XB0
CPU 224 AC/DC/Relay 14 Inputs/10 Relays	6ES7 214-1BD22-0XB0
CPU 226 DC/DC/DC 24 Inputs/16 Outputs	6ES7 216-2AD22-0XB0
CPU 226 AC/DC/Relay 24 Inputs/16 Relays	6ES7 216-2BD22-0XB0
CPU 226XM DC/DC/DC 24 Inputs/16 Relays	6ES7 216-2AF22-0XB0
CPU 226XM AC/DC/Relay 24 Inputs/16 Relays	6ES7 216-2BF22-0XB0
Expansion Modules	Order Number
EM 221 24 VDC Digital 8 Inputs	6ES7 221-1BF22-0XA0
EM 221 Digital 8 AC Inputs (8 x 120/230 VAC)	6ES7 221-1EF22-0XA0
EM 222 24 VDC Digital 8 Outputs	6ES7 222-1BF22-0XA0
EM 222 Digital Output 8 x Relay	6ES7 222-1HF22-0XA0
EM 222 Digital 8 AC Outputs (8 x 120/230 VAC)	6ES7 222-1EF22-0XA0
EM 223 24 VDC Digital Combination 4 Inputs/4 Outputs	6ES7 223-1BF22-0XA0
EM 223 24 VDC Digital Combination 4 Inputs/4 Relay Outputs	6ES7 223-1HF22-0XA0
EM 223 24 VDC Digital Combination 8 Inputs/8 Outputs	6ES7 223-1BH22-0XA0
EM 223 24 VDC Digital Combination 8 Inputs/8 Relay Outputs	6ES7 223-1PH22-0XA0
EM 223 24 VDC Digital Combination 16 Inputs/16 Outputs	6ES7 223-1BL22-0XA0
EM 223 24 VDC Digital Combination 16 Inputs/16 Relay Outputs	6ES7 223-1PL22-0XA0
EM 231 Analog Input, 4 Inputs	6ES7 231-0HC22-0XA0
EM 231 Analog Input RTD, 2 Inputs	6ES7 231-7PB22-0XA0
EM 231 Analog Input Thermocouple, 4 Inputs	6ES7 231-7PD22-0XA0
EM 232 Analog Output, 2 Outputs	6ES7 232-0HB22-0XA0
EM 235 Analog Combination 4 Inputs/1 Output	6ES7 235-0KD22-0XA0
EM 241 Modem Module	6ES7 241-1AA22-0XA0
EM 253 Position Module	6ES7 253-1AA22-0XA0
EM 277 PROFIBUS-DP	6ES7 277-0AA22-0XA0
CP 243-2 AS Interface Communications Processor	6GK7 243-2AX01-0XA0

Cartridges and Cables	Order Number
MC 291, 32K x 8 EEPROM Memory Cartridge	6ES7 291-8GE20-0XA0
CC 292, CPU 22x Real-Time Clock with Battery Cartridge	6ES7 297-1AA20-0XA0
BC 293, CPU 22x Battery Cartridge	6ES7 291-8BA20-0XA0
Cable, I/O Expansion, .8 meters, CPU 22x/EM	6ES7 290-6AA20-0XA0
Cable, PC/PPI, Isolated, 90 deg connector, RTS switch	6ES7 901-3BF21-0XA0
Programming Software	Order Number
STEP 7-Micro/WIN 32 (V3.2) Individual License (CD-ROM)	6ES7 810-2BC02-0YX0
STEP 7-Micro/WIN 32 (V3.2) Upgrade License (CD-ROM)	6ES7 810-2BC02-0YX3
S7-200 Toolbox: TP-Designer for TP070, Version 1.0 (CD-ROM)	6ES7 850-2BC00-0YX0
STEP 7-Micro/WIN Add-on: STEP 7-Micro/WIN 32 Instruction Library, V1.1 (CD-ROM)	6ES7 830-2BC00-0YX0

Communications Cards	Order Number
CP 5411: Short AT ISA	6GK 1 541-1AA00
CP 5511: PCMCIA, Type II	6GK 1 551-1AA00
CP 5611: PCI card (version 3.0 or greater)	6GK 1 561-1AA00
Manuals	Order Number
TD 200 Operator Interface User Manual	6ES7 272-0AA20-8BA0
TP 070 Touch Panel User Manual (English)	6AV6 591-1DC01-0AB0
S7-200 Point-to-Point Interface Communication Manual (English/German)	6ES7 298-8GA00-8XH0
CP 243-2 SIMATIC NET AS-Interface Master Manual (English)	6GK7 243-2AX00-8BA0
S7-200 Programmable Controller System Manual (German)	6ES7 298-8FA22-8AH0
S7-200 Programmable Controller System Manual (English)	6ES7 298-8FA22-8BH0
S7-200 Programmable Controller System Manual (French)	6ES7 298-8FA22-8CH0
S7-200 Programmable Controller System Manual (Spanish)	6ES7 298-8FA22-8DH0
S7-200 Programmable Controller System Manual (Italian)	6ES7 298-8FA22-8EH0
Cables, Network Connectors, and Repeaters	Order Number
MPI Cable	6ES7 901-0BF00-0AA0
PROFIBUS Network Cable	6XVI 830-0AH10
Network Bus Connector with Programming Port Connector, Vertical Cable Outlet	6ES7 972-0BB11-0XA0
Network Bus Connector (no programming port connector), Vertical Cable Outlet	6ES7 972-0BA11-0XA0
RS-485 Bus Connector with 35° Cable Outlet (no programming port connector)	6ES7 972-0BA40-0XA0
RS-485 Bus Connector with 35° Cable Outlet (with programming port connector)	6ES7 972-0BB40-0XA0
CPU 22x/EM Connector Block, 7 Terminal, Removable	6ES7 292-1AD20-0AA0
CPU 22x/EM Connector Block, 12 Terminal Removable	6ES7 292-1AE20-0AA0
CPU 22x/EM Connector Block, 14 Terminal Removable	6ES7 292-1AF20-0AA0
CPU 22x/EM Connector Block, 18 Terminal Removable	6ES7 292-1AG20-0AA0
RS-485 IP 20 Repeater, Isolated	6ES7 972-0AA00-0XA0

Operator Interfaces		Order Number
TD 200 Operator Interface		6ES7 272-0AA20-0YA0
OP3 Operator Interface		6AV3 503-1DB10T
OP7 Operator Interface		6AV3 607-1JC20-0AX1
OP17 Operator Interface		6AV3 617-1JC20-0AX1
TP070 Touch Panel		6AV6 545-0AA15-2AX0
TP170A Touch Panel		6AV6 545-0BA15-2AX0
Miscellaneous		Order Number
DIN Rail Stops		6ES5 728-8MA11
12-Position Fan Out Connector (CPU 221, CPU 222)	10-pack	6ES7 290-2AA00-0XA0
Spare Door Kit, contains 4 each of the following: terminal block covers for 7, 12, 14, 18, 2x12, 2x14 terminals; CPU access door, EM access door		6ES7 291-3AX20-0XA0
8 Position Simulator		6ES7 274 1XF00-0XA0
14 Position Simulator		6ES7 274 1XH00-0XA0
24 Position Simulator		6ES7 274 1XK00-0XA0

Execution Times for STL Instructions

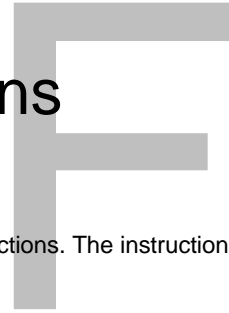

Instruction execution times are very important if your application has time-critical functions. The instruction execution times are shown in Table F-3.



Tip

When you use the execution times in Table F-3, you should consider the effect of power flow to the instruction, the effect of indirect addressing, and the use of certain memory areas on these execution times. These factors can directly effect the listed execution times.

Effect of Power Flow

Table F-3 shows the time required for executing the logic or function of the instruction when power flow is present (Top of Stack = 1 or ON) for that instruction.

When power flow is not present, then the execution time for that instruction is 3 μ s.

Effect of Indirect Addressing

Table F-3 shows the time required for executing the logic, or function, of the instruction when you use direct addressing of the operands and constants.

When instructions use indirectly addressed operands, the execution time for the instruction increases by 22 μ s for each indirectly addressed operand used in the instruction.

Effect of Accessing Certain Memory Areas

Accessing certain memory areas, such as AI, AQ, L, and accumulators require additional execution time.

Table F-1 shows the additional time that must be added to an instruction's execution time when these memory areas are specified in an operand.

Table F-1 Adder for Accessing Memory Areas

Memory Area	Execution Time Adder
Analog Inputs (AI)	
Without analog filtering enabled:	149 μ s
With analog filtering enabled:	0 μ s
Analog Outputs (AQ)	73 μ s
Local memory (L)	5.4 μ s
Accumulators (AC)	4.4 μ s

Effect of Using Certain CPU 226XM Instructions

Executing certain branching-type instructions on a CPU 226XM requires additional execution time.

Table F-2 provides a factor to be added to the basic execution time for each of the listed instructions.

Table F-2 Adder for CPU 226XM Instructions

Instruction	Execution Time Adder
ATCH	1.0 μ s
CALL	4.3 μ s
CSCRE	3.1 μ s
FOR (adder to base)	3.1 μ s
(adder to loop multiplier)	3.1 μ s
INT	1.7 μ s
JMP	3.1 μ s
RET	2.8 μ s

Table F-3 Instruction Execution Times

Instruction		μs	Instruction	μs
=	Using: I SM, T, C, V, S, Q, M L	0.37 1.8 19.2	ATT	70
+D		55	AW <=, =, >=, >, <, <>	45
-D		55	BCDI	66
*D		92	BIR Using: Local inputs Expansion inputs	45 53
/D		376	BIW Using: Local outputs Expansion outputs	46 56
+I		46	BMB Time = Base + (length * LM) Base (constant length) Base (variable length) Length multiplier (LM)	21 51 11
-I		47	BMD Time= Base + (length * LM) Base (constant length) Base (variable length) Length multiplier (LM)	21 51 20
*I		71	BMW Time= Base + (length * LM) Base (constant length) Base (variable length) Length multiplier (LM)	21 51 16
/I		115	BTI	27
=I Using: Local outputs Expansion outputs		29 39	CALL Using no parameters: Using parameters: Time = Base + Σ (operand time) Base Operand time bit (input, output) byte (input, output) word (input, output) Dword (input, output)	15 32 23, 21 21, 14 24, 18 27, 20
+R		110 163 Max	Note: processing of output operands occurs during the return from the subroutine	
-R		113 166 Max	CFND Max Time = Base + N1 * ((LM1 * N2) + LM2) Base Length multiplier 1 (LM1) Length multiplier 2 (LM2) N1 is the length of the source string N2 is the length of the character set string	79 79 9.2 4.4
*R		100 130 Max	COS	1525 1800 Max
/R		300 360 Max	CRET	13
A Using: I SM, T, C, V, S, Q, M L		0.37 1.1 10.8	CRETI	23
AB <=, =, >=, >, <, <>		35	CSCRE	0.9
AD <=, =, >=, >, <, <>		53	CTD On transition of count input Otherwise	48 36
AENO		.6	CTU On transition of count input Otherwise	53 35
AI Using: Local inputs Expansion inputs		27 35	CTUD On transition of count input Otherwise	64 45
ALD		0.37	DECB	30
AN Using: I SM, T, C, V, S, Q, M L		0.37 1.1 10.8	DECD	42
ANDB		37	DECO	36
ANDD		55		
ANDW		48		
ANI Using: Local inputs Expansion inputs		27 35		
AR <=, =, >=, >, <, <>		54		
AS=, <> Time = Base + (LM * N) Base Length multiplier (LM) N is the number of characters compared		51 9.2		
ATCH		20		
ATH Time = Base + (length * LM) Base (constant length) Base (variable length) Length multiplier (LM)		41 55 20		

Instruction	μs	Instruction	μs
DECW	37	ITS	260
DISI	18	JMP	0.9
DIV	119	LBL	0.37
DTA	540	LD Using: I, SM0.0 SM, T, C, V, S, Q, M L	0.37 1.1 10.9
DTI	36	LDB <=, =, >=, >, <, <>	35
DTCH	18	LDD <=, =, >=, >, <, <>	52
DTR	60 70 Max	LDI Using: Local inputs Expansion inputs	26 34
DTS	540	LDN Using: I SM, T, C, V, S, Q, M L	0.37 1.1 10.9
ED	15	LDNI Using: Local inputs Expansion inputs	26 34
ENCO	39 43 Max	LDR<=, =, >=, >, <, <>	55
END	0.9	LDS	0.37
ENI	53	LDS=, <> Time = Base + (LM * N) Base Length multiplier (LM) N is the number of characters compared	51 9.2
EU	15	LDW <=, =, >=, >, <, <>	42
EXP	1170 1375 Max	LIFO	70
FIFO Time = Base + (length * LM) Base Length multiplier (LM)	70 14	LN	1130 1275 Max
FILL Time= Base + (length * LM) Base (constant length) Base (variable length) Length multiplier (LM)	29 50 7	LPP	0.37
FND <, =, >, <> Time = Base + (length * LM) Base Length multiplier (LM)	85 12	LPS	0.37
FOR Time = Base+ (Number of loops * LM) Base Loop multiplier (LM)	64 50	LRD	0.37
GPA	31	LSCR	12
HDEF	35	MEND	0.5
HSC	37	MOVB	29
HTA Time= Base+ (length * LM) Base (constant length) Base (variable length) Length multiplier (LM)	38 48 11	MOVD	38
IBCD	114	MOVR	38
INCB	29	MOVW	34
INCD	42	MUL	70
INCW	37	NEXT	0
INT Typical with 1 interrupt	47	NETR	179
INVB	31	NETW Time = Base + (length * LM) Base Length multiplier (LM)	175 8
INVD	42	NOP	0.37
INVW	38	NOT	0.37
ITA	260	O Using: I SM, T, C, V, S, Q, M L	0.37 1.1 10.8
ITB	27	OB < =, =, >=, >, <, <>	35
ITD	36	OD < =, =, >=, >, <, <>	53

Instruction			μs	Instruction			μs
OI	Using:	Local inputs Expansion inputs	27 35	ROUND			108 183 Max
OLD			0.37	RRB	Total = Base + (length * LM) Base Length multiplier (LM)		42 0.6
ON	Using:	I SM, T, C, V, S, Q, M L	0.37 1.1 10.8	RRD	Total = Base + (length * LM) Base Length multiplier (LM))		52 2.5
ONI	Using:	Local inputs Expansion inputs	27 35	RRW	Total = Base + (length * LM) Base Length multiplier (LM)		49 1.7
OR<=, =, >=, >, <, <>			55	RTA	Time = Base + (LM * N) Base (for first digit in result) Length multiplier (LM) N is the number of additional digits in result		1000 240
ORB			37	RTS	Time = Base + (LM * N) Base (for first digit in result) Length multiplier (LM) N is the number of additional digits in result		1000 240
ORD			55	S	For length = 1 and specified as a constant Otherwise: Time = Base + (length * LM) Base Length multiplier (LM) If length is stored as a variable, add to Base		5 27 0.9 29
ORW			48	SBR			0
OS=, < >		Time + Base + (LM * N) Base Length multiplier (LM) N is the number of characters compared	51 9.2	SCAT	Time = Base + (LM * N) Base Length multiplier (LM) N is the number of appended characters		55 8.8
OW < =, =, >=, >, <, <>			45	SCPY	Time = Base + (LM * N) Base Length multiplier (LM) N is the number of copied characters		43 8.8
PID	Base	Adder for recalculation of integral and differential proportional constants	750 1000	SCORE			0.37
PLS:	Using:	PWM PTO single segment PTO multiple segment	57 67 92	SCRT			17
R	Length=1 and specified as a constant Using operand = C, T Using all other operands Otherwise, Time=Base + (length * LM) Base for operand = C, T Base for all other operands LM for operand = C, T LM for all other operands If length is stored as a variable, add to Base		17, 24 5 19, 19 28 8.6, 16.5 0.9 29	SEG			30
RCV			80	SFND	Max Time = Base + (N1-N2) * ((LM1*N2)+LM2) Base Length multiplier 1 (LM1) Length multiplier 2 (LM2) N1 is the length of the source string N2 is the length of the search string		79 11.5 17.8
RET			13	SHRB	Total = Base + (length * LM1) + ((length / 8) * LM2) Base (constant length) Base (variable length) Length multiplier 1 (LM1) Length multiplier 2 (LM2)		76 84 1.6 4
RETI			23				
RI	Total = Base + (length * LM) Base LM using local outputs LM using expansion outputs If length is stored as a variable, add to Base		18 22 32 30				
RLB	Total = Base + (length + LM) Base Length multiplier (LM)		42 0.6				
RLD	Total = Base + (length * LM) Base Length multiplier (LM))		52 2.5				
RLW	Total = Base + (length * LM) Base Length multiplier (LM)		49 1.7				

Instruction		µs	Instruction		µs
SI	Total = Base + (length * LM)		STD	Time = Base + (LM*N)	
	Base	18		Base (for 1st source character)	84
	LM using local output	22		Length multiplier (LM)	59
	LM using expansion output	32		N is the number of additional source characters	
	If length is stored as a variable, add to Base	30			
SIN		1525 1800 Max	STI		84 59
SLB	Total = Base + (length * LM)		STOP		16
	Base	43	STR		100 120
	Length multiplier (LM)	0.7	SWAP		32
SLD	Total = Base + (length * LM)		TAN		1825 2100 Max
	Base	53	TODR		2400
	Length multiplier (LM)	2.6	TODW		1600
SLEN		46	TOF		64
SLW	Total = Base + (length * LM)		TON		64
	Base	51	TONR		56
	Length multiplier (LM))	1.3	TRUNC		103 178 Max
SPA		243	WDR		16
SQRT		725 830 Max	XMT		78
SRB	Total = Base + (length * LM)		XORB		37
	Base	43	XORD		55
	Length multiplier (LM)	0.7	XORW		48
SRD	Total = Base + (length * LM)				
	Base	53			
	Length multiplier (LM)	2.6			
SRW	Total = Base + (length * LM)				
	Base	51			
	Length multiplier (LM)	1.3			
SSCPY	Time = Base + (LM * N)				
	Base	82			
	Length multiplier (LM)	8.8			
	N is the number of copied characters				

S7-200 Quick Reference Information



To help you find information more easily, this section summarizes the following information:

- Special Memory Bits
- Descriptions of Interrupt Events
- Summary of S7-200 CPU Memory Ranges and Features
- High-Speed Counters HSC0, HSC1, HSC2, HSC3, HSC4, HSC5
- S7-200 Instructions

Table G-1 Special Memory Bits

Special Memory Bits			
SM0.0	Always On	SM1.0	Result of operation = 0
SM0.1	First Scan	SM1.1	Overflow or illegal value
SM0.2	Retentive data lost	SM1.2	Negative result
SM0.3	Power up	SM1.3	Division by 0
SM0.4	30 s off / 30 s on	SM1.4	Table full
SM0.5	0.5 s off / 0.5 s on	SM1.5	Table empty
SM0.6	Off 1 scan / on 1 scan	SM1.6	BCD to binary conversion error
SM0.7	Switch in RUN position	SM1.7	ASCII to hex conversion error

Table G-2 Interrupt Events in Priority Order

Event Number	Interrupt Description	Priority Group	Priority in Group
8	Port 0: Receive character	Communications (highest)	0
9	Port 0: Transmit complete		0
23	Port 0: Receive message complete		0
24	Port 1: Receive message complete		1
25	Port 1: Receive character		1
26	Port 1: Transmit complete		1
19	PTO 0 complete interrupt	Discrete (middle)	0
20	PTO 1 complete interrupt		1
0	I0.0, Rising edge		2
2	I0.1, Rising edge		3
4	I0.2, Rising edge		4
6	I0.3, Rising edge		5
1	I0.0, Falling edge		6
3	I0.1, Falling edge		7
5	I0.2, Falling edge		8
7	I0.3, Falling edge		9
12	HSC0 CV=PV (current value = preset value)		10
27	HSC0 direction changed		11
28	HSC0 external reset		12
13	HSC1 CV=PV (current value = preset value)		13
14	HSC1 direction input changed		14
15	HSC1 external reset		15
16	HSC2 CV=PV		16
17	HSC2 direction changed		17
18	HSC2 external reset		18
32	HSC3 CV=PV (current value = preset value)		19
29	HSC4 CV=PV (current value = preset value)		20
30	HSC4 direction changed		21
31	HSC4 external reset		22
33	HSC5 CV=PV (current value = preset value)	23	
10	Timed interrupt 0	Timed (lowest)	0
11	Timed interrupt 1		1
21	Timer T32 CT=PT interrupt		2
22	Timer T96 CT=PT interrupt		3

Table G-3 Summary of S7-200 CPU Memory Ranges and Features

Description	CPU 221	CPU 222	CPU 224	CPU 226	CPU 226XM
User program size	2 Kwords	2 Kwords	4 Kwords	4 Kwords	8 Kwords
User data size	1 Kwords	1 Kwords	2.5 Kwords	2.5 Kwords	5 Kwords
Process-image input register	I0.0 to I15.7	I0.0 to I15.7	I0.0 to I15.7	I0.0 to I15.7	I0.0 to I15.7
Process-image output register	Q0.0 to Q15.7	Q0.0 to Q15.7	Q0.0 to Q15.7	Q0.0 to Q15.7	Q0.0 to Q15.7
Analog inputs (read only)	—	AIW0 to AIW30	AIW0 to AIW62	AIW0 to AIW62	AIW0 to AIW62
Analog outputs (write only)	—	AQW0 to AQW30	AQW0 to AQW62	AQW0 to AQW62	AQW0 to AQW62
Variable memory (V)	VB0 to VB2047	VB0 to VB2047	VB0 to VB5119	VB0 to VB5119	VB0 to VB10239
Local memory (L) ¹	LB0 to LB63	LB0 to LB63	LB0 to LB63	LB0 to LB63	LB0 to LB63
Bit memory (M)	M0.0 to M31.7	M0.0 to M31.7	M0.0 to M31.7	M0.0 to M31.7	M0.0 to M31.7
Special Memory (SM) Read only	SM0.0 to SM179.7 SM0.0 to SM29.7	SM0.0 to SM299.7 SM0.0 to SM29.7	SM0.0 to SM549.7 SM0.0 to SM29.7	SM0.0 to SM549.7 SM0.0 to SM29.7	SM0.0 to SM549.7 SM0.0 to SM29.7
Timers	256 (T0 to T255)	256 (T0 to T255)	256 (T0 to T255)	256 (T0 to T255)	256 (T0 to T255)
Retentive on-delay	1 ms 10 ms 100 ms	T0, T64 T1 to T4, and T65 to T68 T5 to T31, and T69 to T95	T0, T64 T1 to T4, and T65 to T68 T5 to T31, and T69 to T95	T0, T64 T1 to T4, and T65 to T68 T5 to T31, and T69 to T95	T0, T64 T1 to T4, and T65 to T68 T5 to T31, and T69 to T95
On/Off delay	1 ms 10 ms 100 ms	T32, T96 T33 to T36, and T97 to T100 T37 to T63, and T101 to T255	T32, T96 T33 to T36, and T97 to T100 T37 to T63, and T101 to T255	T32, T96 T33 to T36, and T97 to T100 T37 to T63, and T101 to T255	T32, T96 T33 to T36, and T97 to T100 T37 to T63, and T101 to T255
Counters	C0 to C255	C0 to C255	C0 to C255	C0 to C255	C0 to C255
High-speed counter	HC0, HC3, HC4, and HC5	HC0, HC3, HC4, and HC5	HC0 to HC5	HC0 to HC5	HC0 to HC5
Sequential control relays (S)	S0.0 to S31.7	S0.0 to S31.7	S0.0 to S31.7	S0.0 to S31.7	S0.0 to S31.7
Accumulator registers	AC0 to AC3	AC0 to AC3	AC0 to AC3	AC0 to AC3	AC0 to AC3
Jumps/Labels	0 to 255	0 to 255	0 to 255	0 to 255	0 to 255
Call/Subroutine	0 to 63	0 to 63	0 to 63	0 to 63	0 to 127
Interrupt routines	0 to 127	0 to 127	0 to 127	0 to 127	0 to 127
Positive/negative transitions	256	256	256	256	256
PID loops	0 to 7	0 to 7	0 to 7	0 to 7	0 to 7
Ports	Port 0	Port 0	Port 0	Port 0, Port 1	Port 0, Port 1

¹ LB60 to LB63 are reserved by STEP 7–Micro/WIN, version 3.0 or later.

Table G-4 High-Speed Counters HSC0, HSC3, HSC4, and HSC5

Mode	HSC0			HSC3	HSC4			HSC5
	I0.0	I0.1	I0.2	I0.1	I0.3	I0.4	I0.5	I0.4
0	Clk			Clk	Clk			Clk
1	Clk		Reset		Clk		Reset	
2								
3	Clk	Direction			Clk	Direction		
4	Clk	Direction	Reset		Clk	Direction	Reset	
5								
6	Clk Up	Clk Down			Clk Up	Clk Down		
7	Clk Up	Clk Down	Reset		Clk Up	Clk Down	Reset	
8								
9	Phase A	Phase B			Phase A	Phase B		
10	Phase A	Phase B	Reset		Phase A	Phase B	Reset	
11								

Table G-5 High-Speed Counters HSC1 and HSC2

Mode	HSC1				HSC2			
	I0.6	I0.7	I1.0	I1.1	I1.2	I1.3	I1.4	I1.5
0	Clk				Clk			
1	Clk		Reset		Clk		Reset	
2	Clk		Reset	Start	Clk		Reset	Start
3	Clk	Direction			Clk	Direction		
4	Clk	Direction	Reset		Clk	Direction	Reset	
5	Clk	Direction	Reset	Start	Clk	Direction	Reset	Start
6	Clk Up	Clk Down			Clk Up	Clk Down		
7	Clk Up	Clk Down	Reset		Clk Up	Clk Down	Reset	
8	Clk Up	Clk Down	Reset	Start	Clk Up	Clk Down	Reset	Start
9	Phase A	Phase B			Phase A	Phase B		
10	Phase A	Phase B	Reset		Phase A	Phase B	Reset	
11	Phase A	Phase B	Reset	Start	Phase A	Phase B	Reset	Start

Boolean Instructions		
LD	Bit	Load
LDI	Bit	Load Immediate
LDN	Bit	Load Not
LDNI	Bit	Load Not Immediate
A	Bit	AND
AI	Bit	AND Immediate
AN	Bit	AND Not
ANI	Bit	AND Not Immediate
O	Bit	OR
OI	Bit	OR Immediate
ON	Bit	OR Not
ONI	Bit	OR Not Immediate
LDBx	IN1, IN2	Load result of Byte Compare IN1 (x:<, <=, =, >=, >, <>) IN2
ABx	IN1, IN2	AND result of Byte Compare IN1 (x:<, <=, =, >=, >, <>) IN2
OBx	IN1, IN2	OR result of Byte Compare IN1 (x:<, <=, =, >=, >, <>) IN2
LDWx	IN1, IN2	Load result of Word Compare IN1 (x:<, <=, =, >=, >, <>) IN2
AWx	IN1, IN2	AND result of Word Compare IN1 (x:<, <=, =, >=, >, <>) IN2
OWx	IN1, IN2	OR result of Word Compare IN1 (x:<, <=, =, >=, >, <>) IN2
LDDx	IN1, IN2	Load result of DWord Compare IN1 (x:<, <=, =, >=, >, <>) IN2
ADx	IN1, IN2	AND result of DWord Compare IN1 (x:<, <=, =, >=, >, <>) IN2
ODx	IN1, IN2	OR result of DWord Compare IN1 (x:<, <=, =, >=, >, <>) IN2
LDRx	IN1, IN2	Load result of Real Compare IN1 (x:<, <=, =, >=, >, <>) IN2
ARx	IN1, IN2	AND result of Real Compare IN1 (x:<, <=, =, >=, >, <>) IN2
ORx	IN1, IN2	OR result of Real Compare IN1 (x:<, <=, =, >=, >, <>) IN2
NOT		Stack Negation
EU		Detection of Rising Edge
ED		Detection of Falling Edge
=	Bit	Assign Value
=I	Bit	Assign Value Immediate
S	Bit, N	Set bit Range
R	Bit, N	Reset bit Range
SI	Bit, N	Set bit Range Immediate
RI	Bit, N	Reset bit Range Immediate
LDSx	IN1, IN2	Load result of String Compare IN1 (x: =, <>) IN2
ASx	IN1, IN2	AND result of String Compare IN1 (x: =, <>) IN2
OSx	IN1, IN2	OR result of String Compare IN1 (x: =, <>) IN2
ALD		And Load
OLD		Or Load
LPS		Logic Push (stack control)
LRD		Logic Read (stack control)
LPP		Logic Pop (stack control)
LDS	N	Load Stack (stack control)
AENO		And ENO

Math, Increment, and Decrement instructions		
+I	IN1, OUT	Add Integer, Double Integer or Real
+D	IN1, OUT	IN1+OUT=OUT
+R	IN1, OUT	
-I	IN1, OUT	Subtract Integer, Double Integer, or Real
-D	IN1, OUT	
-R	IN1, OUT	OUT-IN1=OUT
MUL	IN1, OUT	Multiply Integer (16*16->32)
*I	IN1, OUT	Multiply Integer, Double Integer, or Real
*D	IN1, OUT	
*R	IN1, IN2	IN1 * OUT = OUT
DIV	IN1, OUT	Divide Integer (16/16->32)
/I	IN1, OUT	Divide Integer, Double Integer, or Real
/D,	IN1, OUT	OUT / IN1 = OUT
/R	IN1, OUT	
SQRT	IN, OUT	Square Root
LN	IN, OUT	Natural Logarithm
EXP	IN, OUT	Natural Exponential
SIN	IN, OUT	Sine
COS	IN, OUT	Cosine
TAN	IN, OUT	Tangent
INCB	OUT	
INCW	OUT	Increment Byte, Word or DWord
INCD	OUT	
DECB	OUT	
DECW	OUT	Decrement Byte, Word, or DWord
DECD	OUT	
PID	TBL, LOOP	PID Loop
Timer and Counter Instructions		
TON	Txxx, PT	On-Delay Timer
TOF	Txxx, PT	Off-Delay Timer
TONR	Txxx, PT	Retentive On-Delay Timer
CTU	Cxxx, PV	Count Up
CTD	Cxxx, PV	Count Down
CTUD	Cxxx, PV	Count Up/Down
Real Time Clock Instructions		
TODR	T	Read Time of Day clock
TODW	T	Write Time of Day clock
Program Control Instructions		
END		Conditional End of Program
STOP		Transition to STOP Mode
WDR		WatchDog Reset (300 ms)
JMP	N	Jump to defined Label
LBL	N	Define a Label to Jump to
CALL	N [N1,...]	Call a Subroutine [N1, ... up to 16 optional parameters]
CRET		Conditional Return from SBR
FOR	INDX,INIT,FINAL	For/Next Loop
NEXT		
LSCR	N	
SCRT	N	Load, Transition, Conditional End, and End Sequence Control Relay
CSCRE		
SCRE		



Move, Shift, and Rotate Instructions		Table, Find, and Conversion Instructions	
MOVB IN, OUT	Move Byte, Word, DWord, Real	ATT DATA, TBL	Add data to table
MOVW IN, OUT		LIFO TBL, DATA	Get data from table
MOVD IN, OUT		FIFO TBL, DATA	
MOVR IN, OUT		FND= TBL, PTN, INDX	Find data value in table that matches comparison
BIR IN, OUT	FND<> TBL, PTN, INDX		
BIW IN, OUT	FND< TBL, PTN, INDX		
BMB IN, OUT, N	FND> TBL, PTN, INDX		
BMW IN, OUT, N	Block Move Byte, Word, DWord	FILL IN, OUT, N	Fill memory space with pattern
BMD IN, OUT, N		BCDI OUT	Convert BCD to Integer
SWAP IN		IBCD OUT	Convert Integer to BCD
SHRB DATA, S_BIT, N	Shift Register Bit	BTI IN, OUT	Convert Byte to Integer
SRB OUT, N	Shift Right Byte, Word, DWord	ITB IN, OUT	Convert Integer to Byte
SRW OUT, N		ITD IN, OUT	Convert Integer to Double Integer
SRD OUT, N		DTI IN, OUT	Convert Double Integer to Integer
SLB OUT, N	Shift Left Byte, Word, DWord	DTR IN, OUT	Convert DWord to Real
SLW OUT, N		TRUNC IN, OUT	Convert Real to Double Integer
SLD OUT, N		ROUND IN, OUT	Convert Real to Double Integer
RRB OUT, N	Rotate Right Byte, Word, DWord	ATH IN, OUT, LEN	Convert ASCII to Hex
RRW OUT, N		HTA IN, OUT, LEN	Convert Hex to ASCII
RRD OUT, N		ITA IN, OUT, FMT	Convert Integer to ASCII
RLB OUT, N	Rotate Left Byte, Word, DWord	DTA IN, OUT, FM	Convert Double Integer to ASCII
RLW OUT, N		RTA IN, OUT, FM	Convert Real to ASCII
RLD OUT, N		DECO IN, OUT	Decode
Logical Instructions		ENCO IN, OUT	Encode
ANDB IN1, OUT	Logical AND of Byte, Word, and DWord	SEG IN, OUT	Generate 7–segment pattern
ANDW IN1, OUT		ITS IN, FMT, OUT	Convert Integer to String
ANDD IN1, OUT		DTS IN, FMT, OUT	Convert Double Integer to String
ORB IN1, OUT	Logical OR of Byte, Word, and DWord	RTS IN, FMT, OUT	Convert Real to String
ORW IN1, OUT		STI STR, INDX, OUT	Convert Substring to Integer
ORD IN1, OUT		STD STR, INDX, OUT	Convert Substring to Double Integer
XORB IN1, OUT	Logical XOR of Byte, Word, and DWord	STR STR, INDX, OUT	Convert Substring to Real
XORW IN1, OUT		Interrupt Instructions	
XORD IN1, OUT		CRETI	Conditional Return from Interrupt
INVB OUT	Invert Byte, Word and DWord (1's complement)	ENI	Enable Interrupts
INWV OUT		DISI	Disable Interrupts
INVD OUT		ATCH INT, EVNT	Attach Interrupt routine to event
String Instructions		DTCH EVNT	Detach event
SLEN IN, OUT	String Length	Communications Instructions	
SCAT IN, OUT	Concatenate String	XMT TBL, PORT	Freeport transmission
SCPY IN, OUT	Copy String	RCV TBL, PORT	Freeport receive message
SSCPY IN, INDX, N, OUT	Copy Substring from String	NETR TBL, PORT	Network Read
CFND IN1, IN2, OUT	Find First Character within String	NETW TBL, PORT	Network Write
SFND IN1, IN2, OUT	Find String within String	GPA ADDR, PORT	Get Port Address
		SPA ADDR, PORT	Set Port Address
		High-Speed Instructions	
		HDEF HSC, MODE	Define High-Speed Counter mode
		HSC N	Activate High-Speed Counter
		PLS Q	Pulse Output

Index

Symbols

&, 32

*, 32

A

AC installation guidelines, 19

AC outputs and relays, 20

ACCEL_TIME (Acceleration Time), EM 253 Position Module, 249

Access restriction, 44

Accessing

direct addressing, 24

S7-200 data, 24, 32

status chart, 59

Accumulators, 27

Add instruction, 140

Add to table instruction, 189
example, 189

Address

assigning, 58

high-speed counters, 119

Modbus, 331

network, 208

setting remote, 210

symbolic, 58

Address switches, EM 277 PROFIBUS-DP, 374

Addressing

accumulators, 27

analog inputs, 29

analog outputs, 29

bit memory, 25

byte:bit, 24

counter memory, 26

direct, 24

expansion I/O, 31

high-speed counters, 27

indirect (pointers), 32

local I/O, 31

local memory, 28

memory areas, 25–28

process-image input register, 25

process-image output register, 25

S7-200 memory, 24

sequence control relay (SCR) memory, 29

special memory (SM) bits, 28

timer memory, 26

variable memory, 25

AENO instruction, 70

Agency approvals, 338

AI. *See* Analog input (AI)

Alarm checking, PID loop, 151

American Bureau of Shipping (ABS) Maritime Agency, 338

Analog adjustment

potentiometers, 45

SMB28 and SMB29, 412

Analog input (AI)

addressing, 29

filtering, 42

Analog modules, 3

EM 231 analog input, 354

EM 231 RTD, 361

EM 231 thermocouple, 361

EM 232 analog output, 358

EM 235 analog input/output, 355

Analog output (AQ), addressing, 29

AND instruction, 163

example, 164

AND load instruction, 70

AQ. *See* Analog output (AQ)

AS-interface modules, order numbers for manuals, 422

ASCII conversion instructions, 96

ASCII to hex instruction, 96

example, 99

Assigning

addresses, 58

initial values, 58

interrupts to HSC, 119

network addresses, 208

Asynchronous updates, PWM instruction, 127

Attach interrupt instruction, 155

Automatic mode, PID loop, 151

Avoiding, network conflicts, 231

B

Backlash

compensation, 251

selecting work zone, 256

Battery cartridge, 34, 395

order number, 422

Baud rates

network, 218

optimal, 228

setting, 208

switch selections, PC/PPI cable, 6, 210, 221, 223, 226, 397

BCD to integer instruction, 93

Biasing

network cable, 220

PID loop, 145, 147

Bit logic instructions

coil instructions, 68

contact instructions, 66

logic stack instructions, 70

reset dominant bistable, 72

set/reset bistable, 72

Bit memory area (M), 25

saving on power loss, 35

Block diagram, EM 241 modem, 385

Block move byte instruction, 167

Block move double word instruction, 167

Block move instructions, example, 167

- Block move word instruction, 167
- Bookmarks, 236
- Boolean instructions
 - coils, 68
 - contacts, 66
 - logic stack, 70
 - set/reset bistable, 72
- Break detection, 83
- Buffer consistency, PROFIBUS, 378
- Building, network, 218
- Bureau Veritas (BV) Maritime Agency, 338
- Byte address format, 24
- Byte and integer range, 24
- Byte consistency, PROFIBUS, 378
- Byte to integer instruction, 93

C

- C memory, 26
- Cables
 - biasing, 220
 - I/O expansion, 395
 - network, 218, 219
 - order numbers, 422
 - PC/PPI, 396
 - terminating, 220
- Calculating
 - power requirements, 399–401
 - token rotation time, 228
- Calibration
 - EM 231, 353
 - EM 235, 353
 - inputs, 353
- Call subroutine instruction, 203
 - example, 204
- Callback, EM 241 Modem module, 292
- Cartridges
 - memory, 395
 - order numbers, 422
- Changing
 - current value in HSC, 123
 - high-speed counter direction, 123
 - preset value in HSC, 123
 - PTO cycle time, 134
 - PTO cycle time and pulse count, 135
 - PTO pulse count, 135
 - pulse width, 132
- Character interrupt control, 85
- Clearance requirements, 14
- Clock
 - cartridge, 395
 - status bits, 408
- Clock instructions
 - read real-time clock, 73
 - set real-time clock, 73

- Coil instructions
 - no operation, 68
 - output, 68
 - output immediate, 68
 - reset, 68
 - reset immediate, 68
 - set, 68
 - set immediate, 68
- Command Byte, EM 253 Position Module, 283
- Communication
 - S7-200, 7
 - with MicroMaster drives, 312
- Communication processors, CP 243-2, 393
- Communication protocol
 - multi-point interface (MPI), 212, 230
 - point-to-point interface (PPI), 230
 - PROFIBUS, 230
 - selecting, 211
 - user-defined, 222
- Communication requests, processing, 23
- Communication settings, STEP 7-Micro/WIN, 7
- Communications, 208
 - baud rate, 226
 - conflicts, 231
 - Modbus Slave Protocol, 330
 - modem, 226–227
 - protocols supported, 211
- Communications cards, order numbers, 422
- Communications instructions
 - get port address, 88
 - network read, 74
 - network write, 74
 - receive, 79
 - set port address, 88
 - transmit, 79
- Communications port
 - connector pin assignments, 219
 - Freeport mode, 222
 - interrupts, 158
- Communications processing, 40
- Communications processors. *See* CP cards
- Communications protocol
 - point-to-point interface (PPI), 211
 - PROFIBUS, 212
- Communications queue, 159
- Compare byte instruction, 89
- Compare double word instruction, 89
- Compare instructions, 55
 - compare byte, 89
 - compare double word, 89
 - compare integer, 89
 - compare real, 89
 - compare string, 91
 - example, 89
- Compare integer instruction, 89

- Compare real instruction, 89
- Compare string instruction, 91
- Comparing, token rotation times, 230
- Compatibility
 - EM 231 RTD, 362
 - EM 231 thermocouple, 362
 - EM 277 PROFIBUS-DP, 374
- Compile errors, 56
- Compile rule violations, 406
- Complex PPI network, 213
- Concatenate string instruction, 184
- Conditional end instruction, 168
 - example, 169
- Conditional inputs, 55
- Conditional return from interrupt instruction, 155
- Conditional return from subroutine instruction, 203
- Conditional sequence control relay end instruction, 173
- Conditional transitions, example, 178
- Configuration
 - EM 231, 354
 - EM 231 RTD, 368
 - EM 231 thermocouple, 363
 - EM 235, 355
 - EM 253 Position Module, 275
 - EM 277 PROFIBUS-DP, 376–377
 - output states, 40
 - retentive ranges of memory, 41
 - symbol table for Modbus, 331
- Configuration drawings, 49
- Configuration table, EM 241 Modem module, 293, 306
- Configuration/Profile table, EM 253 Position Module, 278
- Configuring
 - FBD and LAD status display, 238
 - network, 218
 - password, 44
 - PTO/PWM operation, 128
 - STL status display, 239
- Conflicts, avoiding network, 231
- Connecting
 - MM3 drive, 324
 - MM4 drive, 327
 - modem to S7-200, 226
 - network devices, 230
 - PC/PPI cable, 6
 - with S7-200, 7
- Connections, CP 243-2, 394
- Connector pins, communications port assignments, 219
- Connector terminals
 - CPU 221 AC/DC/Relay, 343
 - CPU 221 DC/DC/DC, 343
 - CPU 222 AC/DC/Relay, 344
 - CPU 222 DC/DC/DC, 344
 - CPU 224 AC/DC/Relay, 344
 - CPU 224 DC/DC/DC, 344
 - CPU 226 AC/DC/Relay, 345
 - CPU 226 DC/DC/DC, 345
 - CPU 226XM AC/DC/Relay, 345
 - CPU 226XM DC/DC/DC, 345
- Connector terminals (continued)
 - EM 221 DI 8 x AC, 349
 - EM 221 DI 8x24 VDC, 349
 - EM 222 DO 8 x Relay, 349
 - EM 223 DI 16/DO 16 x 24 VDC Relay, 350
 - EM 222 DO 8x24 VDC, 349
 - EM 223 4x24 VDC In/4x24 VDC Out, 349
 - EM 223 DI 16/DO 16 x DC 24V, 350
 - EM 223 DI 4/DO 4 x DC 24V/Relay, 349
 - EM 223 DI 8/ DO 8 x 24 VDC/Relay, 350
 - EM 223 DI 8/DO 8 x 24 VDC, 350
 - EM 231 AI 4 x 12 Bit, 352
 - EM 231 RTD, 362
 - EM 231 thermocouple, 362
 - EM 232 AQ 2 x 12 Bit, 352
 - EM 235 AI 4/AQ 1 x 12 Bit, 352
- Connectors, order numbers, 422
- Constant values, 30
- Contact instructions, 66
 - example, 67
- Control byte, setting for HSC, 118
- Control logic, 22
- Conventions
 - program editors, 54
 - S7-200 programming, 55
- Convergence control
 - example, 177
 - sequence control relay instructions, 176
- Conversion instructions
 - ASCII, 96
 - ASCII to hex, 96
 - decode, 105
 - encode, 105
 - example, 94
 - hex to ASCII, 96
 - round, 94
 - segment, 95
 - standard, 92
 - string, 100, 103
 - truncate, 94
- Convert double integer to string instruction, 100, 103
- Convert integer to string instruction, 100, 103
- Convert real to string instruction, 100, 103
- Convert substring to double integer instruction, 100, 103
- Convert substring to integer instruction, 100, 103
- Convert substring to real instruction, 100, 103
- Converting
 - loop inputs, 149
 - loop outputs to scaled integer, 150
- Copy string instruction, 184
- Copy substring from string instruction, 186
- Copying, program to memory cartridge, 36
- Cosine instruction, 143
- Count down counter instruction, 106
 - example, 108
- Count up counter instruction, 106
- Count up/down counter instruction, 106
 - example, 108

- Counter instructions
 - high-speed counter (HSC), 111
 - high-speed counter definition (HDEF), 111
 - IEC
 - down counter, 109
 - up counter, 109
 - up/down counter, 109
 - SIMATIC
 - count down counter, 106
 - count up counter, 106
 - count up/down counter, 106
 - Counter memory area (C), 26
 - Counters, high-speed, 46
 - Country codes, supported by EM 241, 288
 - CP 243-2 communications processor
 - connections, 394
 - features, 393
 - functions, 394
 - operation, 394
 - order number, 393
 - CP cards
 - order numbers, 422
 - selecting, 220
 - CP242, CP243 modules, order numbers for manuals, 422
 - CP5411, 422
 - CP5511, 422
 - CP5611, 422
 - CPU
 - backup, 2
 - comm ports, 2
 - digital I/O, 2
 - dimensions, 2
 - error handling, 56
 - execution speed, 2
 - expansion modules, 2
 - ID register (SMB6), 410
 - input simulators, 398
 - memory, 2
 - password protection, 44
 - power requirements, 15, 399
 - real-time clock, 2
 - scan cycle, 22
 - screw sizes for installation, 16
 - CPU 224, sample DP program, 383
 - CPU Data Transfer Message Format, EM 241 Modem module, 310
 - CPU modules
 - features, 64, 461
 - input specifications, 341
 - installing, 16
 - memory ranges, 64, 433, 461
 - order numbers, 340, 421
 - output specifications, 342
 - power specifications, 341
 - removing, 17
 - self-test diagnostics, 23
 - specifications, 340
 - wiring diagrams, 343-345
 - CPUs, supporting intelligent modules, 303
 - CRC table, Modbus Slave Protocol, 330
 - Creating
 - configuration drawings, 49
 - program, 8
 - program with Micro/WIN, 51
 - symbolic name list, 49
 - user-defined protocols, 222
 - Cross reference table, 236
 - Current value
 - changing in HSC, 123
 - setting for HSC, 118
 - Cycle time (PTO function), 125
- ## D
- Data
 - receiving, 80, 85
 - saving and restoring, 34
 - transmitting, 80
 - Data block, 50
 - Data block editor
 - assigning addresses, 58
 - assigning initial values, 58
 - Data consistency, PROFIBUS, 378
 - Data exchange mode, EM 277 PROFIBUS-DP, 378
 - Data transfers, EM 241 Modem module, 291
 - Data types, subroutine parameters, 204
 - Date, setting, 73
 - DC installation guidelines, 19
 - DC outputs and relays, 20
 - DC transistor, protecting, 20
 - Debugging
 - editing in RUN mode, 236
 - features, 236
 - forcing values, 240
 - multiple scans, 240
 - DECCEL_TIME (Deceleration Time), EM 253 Position Module, 249
 - Decode instruction, 105
 - example, 105
 - Decrement instruction, 144
 - example, 144
 - Designing
 - Micro PLC system, 48
 - safety circuits, 48
 - Det Norske Veritas (DNV) Maritime Agency, 338
 - Detach interrupt instruction, 155
 - Device database file (GSD), EM 277 PROFIBUS-DP, 381-382
 - Diagnostics, CPU self-test, 23
 - Diagnostics information, EM 253 Position Module, 275
 - Differential term, PID algorithm, 148
 - Digital expansion module, addressing, 31
 - Digital inputs
 - filtering, 41
 - pulse catch, 41
 - reading, 39
 - Digital outputs, configuring states, 40
 - Dimensions, CPU, 2
 - DIN rail mounting, 16
 - Diode suppression, 20
 - DIP switch settings, PC/PPI cable, 6, 223

- DIP switches
 - RTD, 368–369
 - thermocouple, 364
 - Direction, changing in HSC, 123
 - Disable interrupt instruction, 155
 - Disabling, high-speed counters, 123
 - Discrete modules, 3
 - Display panels
 - TD 200 text display, 4
 - TP070 touch panel, 4
 - Displaying
 - program elements, 51
 - program status, 238
 - Divergence control
 - example, 176
 - sequence control relay instructions, 176
 - Divide instruction, 140
 - Divide integer with remainder instruction (DIV), 142
 - example, 142
 - Double integer to ASCII instruction, 97
 - Double integer to integer instruction, 93
 - Double integer to real instruction, 93
 - Down counter instruction, 109
 - Downloading, program, 11, 34
 - Drawings, creating configuration, 49
 - Drive communication, calculating time requirement, 313
 - Drives. *See* MicroMaster drives
- E**
- Editing, in RUN mode, 236
 - Editors
 - Function Block Diagram (FBD), 52
 - Ladder Logic (LAD), 52
 - Statement List (STL), 51
 - EEPROM, 34
 - error codes, 404
 - saving bit memory (M), 35
 - saving variable memory (V), 38, 413
 - Electric service life, 338
 - Electromagnetic
 - compatibility, S7-200, 339
 - emission standards, 339
 - immunity standards, 339
 - EM 231 analog input module
 - accuracy and repeatability, 359
 - calibration, 353
 - configuration, 354
 - input block diagram, 356
 - input data word format, 356
 - installation, 358
 - specifications, 360
 - EM 231 RTD module
 - configuring, 368
 - connector terminals, 362
 - CPU compatibility, 362
 - selecting DIP switches, 368–369
 - specifications, 361
 - status indicators, 370
 - temperature ranges and accuracy, 371–372
 - EM 231 thermocouple module
 - basics, 363
 - configuring, 363
 - connector terminals, 362
 - CPU compatibility, 362
 - selecting DIP switches, 364
 - specifications, 361
 - status indicators, 365
 - temperature ranges and accuracy, 366–367
 - EM 232 analog output module
 - output block diagram, 358
 - output data word format, 357
 - EM 235 analog input/output module
 - accuracy and repeatability, 359
 - calibration, 353
 - configuration, 355
 - input block diagram, 357
 - input data word format, 356
 - installation, 358
 - output block diagram, 358
 - output data word format, 357
 - specifications, 360
 - EM 241 Modem Module
 - block diagram, 385
 - configuration table, 293, 306
 - countries supported, 288
 - CPU Data Transfer Message Format, 310
 - Data transfers, 291
 - errors from instructions, 301
 - example, 303
 - features, 288
 - installing, 386
 - instructions, 298
 - International telephone line interface, 288
 - Messaging Telephone Number, 308
 - MOD_XFR instruction, 299
 - Modbus addresses, 290
 - Modbus RTU protocol, 289
 - Modem Expansion wizard, 294
 - MODx_CTRL instruction, 299
 - MODx_MSG instruction, 300
 - numeric paging, 290
 - paging, 290
 - password protection, 291
 - RJ11 jack, 288
 - security callback, 292
 - Short Message Service (SMS), 290
 - special memory locations, 304
 - specifications, 385
 - status LEDs, 294
 - STEP 7-Micro/WIN Interface, 289
 - text paging, 290
 - EM 253 Control Panel, 274–276

- EM 253 Position Module
 - ACCEL_TIME, 249
 - command byte, 283
 - configuration, 275
 - Configuration/Profile table, 278
 - configuring, 246
 - creating instructions, 286
 - DECEL_TIME, 249
 - diagnostics information, 275
 - displaying and controlling operation, 274
 - eliminating backlash, 256
 - EM 253 Control Panel, 274–276
 - error codes, 276
 - Features, 244
 - Input Active Levels, 247
 - Input Filter Times, 247
 - inputs and outputs, 244
 - instruction error codes, 276
 - instruction guidelines, 257
 - instructions, 257
 - jerk time, 250
 - jog parameters, 249
 - maximum and Start/Stop speeds, 248
 - measurement type, selecting, 246
 - module error codes, 277
 - motion commands, 284
 - Motion Control wizard, 246
 - motion profile, defining, 252
 - Negative Polarity, 247
 - Positive Polarity, 247
 - POSx_CFG, 268
 - POSx_CLR, 267
 - POSx_CTRL, 258
 - POSx_DIS, 266
 - POSx_GOTO, 260
 - POSx_LD OFF, 263
 - POSx_LD POS, 264
 - POSx_MAN, 259
 - POSx_RSEEK, 262
 - POSx_RUN, 261
 - POSx_SRATE, 265
 - profile mode of operation, 252
 - profile steps, 253
 - profiles, 252
 - programming, 245
 - Pulse and Directional Outputs, 247
 - Reference point (RP), 250
 - Reference Point Seek (RS seek), 250
 - response to physical inputs, 248
 - RP seek modes, 253–257
 - RP Seek Sequence, 251
 - sample program to control module, 286
 - examples, 269–273
 - special memory, 281
 - SS_SPEED, 248
 - wiring diagram, 391–392
- EM 277 PROFIBUS-DP module
 - additional features, 380
 - address switches, 374
 - as DP slave, 375
 - configuration file, 381–382
 - configuration options, 377
 - configuring, 376–377
 - CPU compatibility, 374
 - data exchange mode, 378
 - DP protocol, 375
 - LED status indicators, 380
 - on PROFIBUS network, 375
 - special memory bytes, 379
 - specifications, 373
 - status LEDs, 374
- Embedded variables, in text and SMS messages, 291
- EN, 55, 63
- Enable in (EN), 55
- Enable interrupt instruction, 155
- Enable out (ENO), 55
- Encode instruction, 105
 - example, 105
- End character detection, 84
- End instruction, 168
- ENO, 55, 63
- Entering, instruction, 9
- Environmental specifications
 - operating, 339
 - transport and storage, 339
- Equipment requirements, 3
- Error codes, 404
 - compile rule violations, 406
 - EM 253 Position module, 276
 - fatal errors, 404
 - instructions for EM 253 Position Module, 276
 - module errors for EM 253 Position Module, 277
 - run-time programming problems, 405
 - USS protocol instructions, 323
- Errors
 - EM 241 Modem module configuration, 293
 - EM 241 Modem module instructions, 301
 - fatal, 57
 - handling, 56
 - I/O, 57
 - Modbus Slave Protocol execution, 335
 - network read and write instructions, 75
 - non-fatal, 56
 - PID loop, 151
 - program compile, 56
 - program execution, 57
 - run-time, 57
 - SMB1, execution errors, 408
 - viewing, 56

Examples

- add to table instruction, 189
- AND instruction, 164
- ASCII to hex instruction, 99
- block move instruction, 167
- calculating power requirements, 399
- compare instructions, 89
- conditional end instruction, 169
- conditional transitions, 178
- contact instructions, 67
- convergence of control streams, 177
- count down counter instruction, 108
- count up/down counter instruction, 108
- decode instructions, 105
- decrement instruction, 144
- DIV instruction, 142
- divergence of control streams, 176
- EM 241 Modem module, 303
- encode instructions, 105
- first-in-first-out instruction, 190
- for-next loop instructions, 171
- Freeport mode, 222
- high-speed counter instructions, 124
- high-speed counter modes, 114
- IEC counter instructions, 109
- IEC timers, 201
- increment instruction, 144
- integer math instructions, 141
- integer to ASCII instruction, 99
- interrupt instructions, 161
- interrupt routines, 49
- invert instructions, 162
- jump to label instruction, 172
- last-in-first-out instruction, 191
- logic stack instructions, 71
- memory fill instruction, 192
- Modbus Slave Protocol, programming, 336
- move instructions, 183
- MUL instruction, 142
- multiple-segment PTO, 138
- network read/write instructions, 77
- off-delay timer instruction, 199
- on-delay timer instruction, 198
- OR instruction, 164
- PID loop instruction, 153
- PID program, 152
- Position module, 269–273
- pulse width modulation (PWM), 132
- real math instructions, 141
- real to ASCII instruction, 99
- receive instructions, 86
- reset instruction, 68
- retentive on-delay timer instruction, 200
- return from subroutine instructions, 205
- rotate instructions, 180
- segment instruction, 95
- sequence control relay instructions, 173
- set instruction, 68
- shift instructions, 180
- shift register bit instruction, 182
- SIMATIC counters, 108

- SIMATIC timers, 198, 199, 200
- single-segment PTO, 136
- standard conversion instructions, 94
- stop instruction, 169
- subroutine, 49
- subroutine call, 204
- subroutine instructions, 205
- swap instructions, 183

Examples

- table find instruction, 195
- timed interrupt routine, 161
- token-passing network, 229
- transmit instructions, 86
- USS protocol program, 322
- watchdog reset instruction, 169
- XOR instruction, 164

Exclusive OR instruction, 163

- example, 164

Executing

- control logic, 22
- instructions, 23

Execution error codes, USS protocol instructions, 323

Execution errors, 57

Execution times, STL instructions, 425

Expansion cable, 395

Expansion I/O, 31

- bus errors (SMW98), 417

Expansion modules, 3

- addressing I/O points, 31
- dimensions, 16
- ID and error register, 411
- installing, 16
- order numbers, 421
- power requirements, 15, 399
- removing, 17

Expansion modules (EM)

- analog
 - input specifications, 351
 - order numbers, 351, 361
 - output specifications, 352
 - specifications, 351
 - wiring diagrams, 352
- digital, order numbers, 346
- discrete
 - general specifications, 346
 - input specifications, 346
 - output specifications, 347
 - wiring diagrams, 349–350

F

Fatal errors, 57

- viewing, 404

FBD editor

- conventions, 54
- description, 52
- features, 52

Features

- CPU modules, 64, 461
- EM 241 Modem module, 288
- EM 253 Position Module, 244

Fill instruction, 192

Filtering

- analog inputs, 42
- digital inputs, 41

Find first character within string instruction, 187

Find instruction, 193

Find string within string instruction, 187

First-in-first-out instruction, 190

- example, 190

Floating point values, 29, 149

For-next loop instructions

- example, 171
- for, 170
- next, 170

Forcing values, 239, 240

Forward-acting loops, 150

Freeport communication, 409

- SMB30 and SMB130, 412

Freeport control registers (SMB30 and SMB130), 412

Freeport mode

- changing from PPI, 80
- character interrupt control, 85
- definition, 158
- enabling, 79
- example, 222
- parity error (SMB3), 409
- receive character (SMB2), 409
- RS-232 standard, 223
- transmit and receive instructions, 79
- user-defined protocols, 222

Function Block Diagram. *See* FBD editor

Functions, Modbus, 332

G

Gap update factor (GUF), 228

Germanisher Lloyd (GL) Maritime Agency, 338

Get port address instruction, 88

Global variable table, 58

Grounding, 18, 19

GSD file, EM 277 PROFIBUS-DP, 381–382

Guidelines

- designing a Micro PLC system, 48
- grounding and circuit, 18
- grounding and wiring, 19
- high-vibration environment, 17
- installation, 14
- instructions for EM 253 Position Module, 257
- interrupt routines, 50, 157
- isolation, 18
- modifying pointers for indirect addressing, 32
- network configuration, 218
- subroutines, 50
- suppression circuits, 20
- vertical installation, 17
- wiring, 18

H

Handling

- complex communications, 231
- errors, 56

Hardware, troubleshooting, 241

Hex to ASCII instruction, 96

High potential isolation test, 339

High-speed counter (HSC) instruction, 111

- example, 124

High-speed counter definition (HDEF) instruction, 111

High-speed counters, 46

- addressing, 119
- assigning interrupts, 119
- changing current value, 123
- changing direction, 123
- changing preset value, 123
- control byte, 112
- defining modes and inputs, 113
- disabling, 123
- initialization sequence, 120
- interrupts, 113
- memory area, addressing, 27
- modes, 114, 434
- programming, 112
- reset and start operations, 116
- selecting active state, 117
- setting control byte, 118
- setting current and preset values, 118
- SMB36–SMB65, 413
- status byte, 119
- timing diagrams, 114–116
- understanding, 112

High-speed pulse output

- changing pulse width, 132
- operation, 125
- SMB66–SMB85, 415

High-speed pulse outputs, 46

Highest station address (HSA), 228

HMI devices, 221

HSC, 46

HSC0, HSC1, HSC2 register (SMB36 to SMB65), 413

HSC3, HSC4, HSC5 register (SMB131 to SMB165), 417

I

I memory, 25

I/O, reading and writing, 39

I/O addressing, 31

I/O errors, 57

I/O expansion cable, installation, 395

I/O interrupt queue, 159

I/O interrupts, 158

I/O module identification and error register, 411

I/O status (SMB5), 410

Idle line detection, 82

- IEC 1131-3 instruction set, 53
- IEC counter instructions
 - down counter, 109
 - example, 109
 - up counter, 109
 - up/down counter, 109
- IEC timer instructions, 201
 - example, 201
- Immediate contact instruction, 66
- Increment instruction, 144
 - example, 144
- Incrementing pointers, 32
- Indirect addressing, 32
 - & and *, 32
 - modifying pointers, 32
- Initial values, assigning, 58
- Initializing
 - high-speed counters, 120
 - Modbus Protocol, 330
 - PTO for multiple-segment operation, 135
 - PTO for single-segment operation, 134
 - PWM output, 132
- Input Active Levels, EM 253 Position Module, 247
- Input block diagram
 - EM 231, 356
 - EM 235, 357
- Input configurations, editing defaults in EM 253 Position Module, 247
- Input data word format
 - EM 231, 356
 - EM 235, 356
- Input Filter Times, EM 253 Position Module, 247
- Input image register, 23
- Input simulators, 398
- Input specifications
 - analog expansion module, 351
 - CPU modules, 341
 - discrete expansion module, 346
- Inputs, 22, 23
 - calibration, 353
 - conditional/unconditional, 55
 - CPU module, 343
 - discrete expansion module, 348
 - EM 253 Position Module, 244
 - filtering analog, 42
 - filtering digital, 41
 - high-speed counters, 113
 - start and reset (HSC), 116
- Installation
 - clearance requirements, 14
 - CPU module, 16
 - electrical noise, 14
 - EM 231, 358
 - EM 235, 358
 - expansion module, 16
 - guidelines, 14
 - heat-generating devices, 14
 - high voltage devices, 14
 - I/O expansion cable, 395
 - memory cartridge, 36
 - mounting requirements, 16
 - power supply, 15
 - S7-200, 15
 - STEP 7-Micro/WIN, 4
- Instruction, entering, 9
- Instruction error codes, EM 253 Position Module, 276
- Instruction Libraries, 60
- Instruction sets
 - IEC 1131-3, 53
 - selecting, 53
 - SIMATIC, 53
- Instruction tree, 9, 51
- Instructions
 - add, 140
 - add to table, 189
 - AENO, 70
 - AND, 163
 - AND load, 70
 - ASCII to hex, 96
 - attach interrupt, 155
 - BCD to integer, 93
 - bit logic, 66
 - block move byte, 167
 - block move double word, 167
 - block move word, 167
 - byte to integer, 93
 - call subroutine, 203
 - compare, 55
 - concatenate string, 184
 - conditional end, 168
 - conditional return from interrupt, 155
 - conditional return from subroutine, 203
 - conditional sequence control relay end, 173
 - convert double integer to string, 100, 103
 - convert integer to string, 100, 103
 - convert real to string, 100, 103
 - convert substring to double integer, 100, 103
 - convert substring to integer, 100, 103
 - convert substring to real, 100, 103
 - copy string, 184
 - copy substring from string, 186
 - cosine, 143
 - count down counter, 106
 - count up counter, 106
 - count up/down counter, 106
 - creating motion, 286
 - decode, 105
 - decrement, 144
 - detach interrupt, 155
 - disable interrupt, 155
 - divide, 140
 - divide integer with remainder (DIV), 142
 - double integer to ASCII, 97
 - double integer to integer, 93

Instructions (continued)

- double integer to real, 93
- down counter, 109
- EM 241 Modem module, 298
- EM 253 Position Module, 257
- enable interrupt, 155
- encode, 105
- End, 168
- exclusive OR, 163
- executing, 23
- find first character within string, 187
- find string within string, 187
- first-in-first-out, 190
- for, 170
- get port address, 88
- hex to ASCII, 96
- high-speed counter (HSC), 111
- high-speed counter definition (HDEF), 111
- high-speed pulse output (PLS), 125
- immediate contact, 66
- increment, 144
- integer to ASCII, 96
- integer to BCD, 93
- integer to byte, 93
- integer to double integer, 93
- interrupt, 155–161
- invert byte, 162
- invert double word, 162
- invert word, 162
- jump to label, 172
- label, 172
- last-in-first-out, 190
- load sequence control relay, 173
- load stack, 70
- logic pop, 70
- logic push, 70
- logic read, 70
- loop control (PID), 145
- MBUS_INIT, 333
- MBUS_SLAVE, 335
- memory fill, 192
- Modbus Slave Protocol, 332
- MODx_CTRL, 299
- MODx_MSG, 300
- MODx_XFR, 299
- move byte, 165
- move byte immediate read, 166
- move byte immediate write, 166
- move double word, 165
- move real, 165
- move word, 165
- multiply, 140
- multiply integer to double integer (MUL), 142
- natural exponential, 143
- natural logarithm, 143
- negative transition, 66
- network read, 74
- network write, 74
- next, 170
- no operation, 68
- NOT, 66
- off-delay timer (TOF), 196, 201
- on-delay timer (TON), 196, 201
- OR, 163
- OR load, 70
- output, 68
- output immediate, 68
- PID loop, 145
- positive transition, 66
- POSx_CFG, 268
- POSx_CLR, 267
- POSx_CTRL, 258
- POSx_DIS, 266
- POSx_GOTO, 260
- POSx_LDOFF, 263
- POSx_LDPOS, 264
- POSx_MAN, 259
- POSx_RSEEK, 262
- POSx_RUN, 261
- POSx_SRATE, 265
- pulse output (PLS), 125
- pulse timer (TP), 201
- pulse train output (PTO), 125
- pulse width modulation (PWM), 125
- read real-time clock, 73
- real to ASCII, 98
- real-time clock, 73
- receive, 79
- reset, 68
- reset dominant bistable, 72
- reset immediate, 68
- retentive on-delay timer (TONR), 196
- return from interrupt, 155
- return from subroutine, 203
- rotate left byte, 179
- rotate left double word, 179
- rotate left word, 179
- rotate right byte, 179
- rotate right double word, 179
- rotate right word, 179
- round, 94
- segment, 95
- sequence control relay end, 173
- sequence control relay transition, 173
- set, 68
- set dominant bistable, 72
- set immediate, 68
- set port address, 88
- set real-time clock, 73
- shift left byte, 179
- shift left double word, 179
- shift left word, 179
- shift register bit, 181
- shift right byte, 179
- shift right double word, 179
- shift right word, 179
- sine, 143
- square root, 143
- standard contact, 66
- stop, 168
- string length, 184
- subtract, 140

- Instructions (continued)
 - swap bytes, 183
 - table, 190–195
 - table find, 193
 - tangent, 143
 - transmit, 79
 - truncate, 94
 - up counter, 109
 - up/down counter, 109
 - USS protocol, 314
 - watchdog reset, 168
 - without outputs, 55
- Instructions, quick reference guide, 435
- Integer math instructions, example, 141
- Integer to ASCII instruction, 96
 - example, 99
- Integer to BCD instruction, 93
- Integer to byte instruction, 93
- Integer to double integer instruction, 93
- Integral term, PID algorithm, 147
- Intelligent modules, 3
 - CPUs that support, 303
 - status (SMB200 to SMB549), 419
- Intercharacter timer, 84
- International standards, 338
- Interrupt events
 - priority, 160
 - quick reference, 432
 - types, 156
- Interrupt instructions
 - attach interrupt, 155
 - conditional return from interrupt, 155
 - detach interrupt, 155
 - disable interrupt, 155
 - enable interrupt, 155
 - example, 161
- Interrupt routines, 23, 39
 - calling subroutines from, 158
 - communication port, 158
 - example, 49
 - guidelines, 50, 157
 - I/O, 158
 - priority, 159
 - queues, 159
 - rising/falling edge, 158
 - sharing data with main program, 157
 - system support, 157
 - time-based, 158
 - types supported by S7-200, 158
 - understanding, 157
- Interrupts
 - assigning to HSC, 119
 - high-speed counters, 113
- Invert byte instruction, 162
- Invert double word instruction, 162
- Invert instructions, example, 162
- Invert word instruction, 162
- Isolation
 - network, 218
 - wiring guidelines, 18
- J**
- Jerk Time, EM 253 Position Module, 250
- Jog parameters
 - EM 253 Position Module, 249
 - jog operation, 249
- JOG_INCREMENT, EM 253 Position Module, 249
- JOG_SPEED, EM 253 Position Module, 249
- Jump instructions
 - jump to label, 172
 - label, 172
- Jump to label instruction, 172
 - example, 172
- L**
- L memory, 28
- Label instruction, 172
- LAD editor
 - conventions, 54
 - description, 52
 - features, 52
- Ladder Logic. *See* LAD editor
- Last-in-first-out instruction, 190
 - example, 191
- LEDs, EM 241 Modem module, 294
- Libraries, Instruction, 60
- Lloyds Register of Shipping (LRS) Maritime Agency, 338
- Load sequence control relay instruction, 173
- Load stack instruction, 70
- Loading
 - new current value in HSC, 123
 - new preset value in HSC, 123
- Local I/O, 31
- Local memory area (L), 28
- Local variable table, 51, 59
- Logic pop instruction, 70
- Logic push instruction, 70
- Logic read instruction, 70
- Logic stack instructions
 - AENO, 70
 - AND load, 70
 - example, 71
 - load stack, 70
 - logic pop, 70
 - logic push, 70
 - logic read, 70
 - OR load, 70
- Logic, control, 22
- Logical connections
 - MPI, 212
 - PPI, 211

- Logical operations instructions
 - AND, OR, XOR, 163
 - invert, 162
- Loop control
 - (PID) instructions, 145–156
 - adjusting bias, 150
 - converting inputs, 149
 - converting outputs, 150
 - error conditions, 151
 - forward/reverse, 150
 - modes, 151
 - program example, 152–154
 - ranges/variables, 150
 - selecting type, 148
- Loop inputs
 - converting, 149
 - normalizing, 149
- Loop outputs, converting to scaled integer, 150
- Loop table, 152
- Lost password, 45

M

- M memory, 25
- Manual mode, PID loop, 151
- Manuals, order numbers, 422
- Mapping address to S7–200, Modbus, 331
- Maritime Agency approvals, 338
- Master devices, 208
- Math instructions
 - add, 140
 - decrement, 144
 - divide, 140
 - divide integer with remainder (DIV), 142
 - increment, 144
 - multiply, 140
 - multiply integer to double integer (MUL), 142
 - subtract, 140
- MAX_SPEED, EM 253 Position Module, 248
- Maximum character count, 85
- MBUS_INIT instruction, 333
- MBUS_SLAVE instruction, 335
- Measurement type, EM 253 Position Module, 246
- Memory
 - accessing, 24
 - CPU, 2
 - restoring from EEPROM, 35
 - retentive, 41
- Memory areas
 - clearing, 45
 - operand ranges, 65
- Memory cartridge, 34, 36, 395
 - copying program, 36
 - error codes, 404
 - installing, 36
 - order number, 422
 - restoring program, 37

- Memory fill instruction, 192
 - example, 192
- Memory functions
 - block move instructions, 167
 - move instructions, 165
 - rotate instructions, 179
 - shift instructions, 179
 - shift register bit instruction, 181
 - swap instructions, 183
- Memory ranges
 - CPU modules, 64, 461
 - quick reference, 433
- Memory retention, 34–37
 - battery cartridge (optional), 34
 - EEPROM, 34–36
 - power on, 35–37
 - ranges, 41
- Message timer, 84
- Messages, token-passing network, 229
- Messaging Telephone Number Format, EM 241 Modem module, 308
- Micro PLC system, designing, 48
- Micro/WIN. *See* STEP 7–Micro/WIN
- MicroMaster drive
 - communication, 312
 - connecting, 324
 - controlling, 311
 - reading and writing, 319, 320
- MM3 drive
 - connecting, 324
 - setup, 325
- MM4 drive
 - connecting, 327
 - setup, 328
- Modbus Protocol Library, 329
- Modbus RTU Protocol, 332
 - EM 241 Modem module, 289
 - functions supported by Modem module, 289
 - mapping addresses, 290
- Modbus Slave Protocol
 - addresses, 331
 - configuring symbol table, 331
 - CRC table, 330
 - example of programming, 336
 - execution error codes, 335
 - execution time, 330
 - functions supported, 332
 - initialization, 330
 - instructions, 332
 - mapping addresses to S7–200, 331
 - MBUS_INIT, 333
 - MBUS_SLAVE, 335
 - resources used, 330
 - special memory, 330
- Mode switch, 37
- Modem, with PC/PPI cable, 226
- Modem Expansion Wizard, EM 241 Modem module, 294

- Modem module, 385
 - configuration table, 293
 - CPU Data Transfer Message Format, 310
 - data transfers, 291
 - errors from instructions, 301
 - example, 303
 - features, 288
 - instructions, 298
 - International telephone line interface, 288
 - Messaging Telephone Number, 308
 - Modem Expansion wizard, 294
 - MODx_CTRL instruction, 299
 - MODx_MSG instruction, 300
 - MODx_XFR instruction, 299
 - numeric paging, 290
 - paging, 290
 - password protection, 291
 - RJ11 jack, 288
 - security callback, 292
 - Short Message Service, 290
 - SMS messaging, 290
 - status LEDs, 294
 - Text Message Format, 309
 - text paging, 290
 - Modes
 - high-speed counters, 113
 - PID loop, 151
 - Modifying, pointers, 32
 - Module error codes, EM 253 Position Module, 277
 - MODx_CTRL instruction, EM 241 Modem module, 299
 - MODx_XFR instruction, EM 241 Modem module, 299
 - MODx_MSG instruction, EM 241 Modem module, 300
 - Monitoring, 11
 - process variables, 59
 - program status, 238
 - variables with status chart, 239
 - Motion commands, EM 253 Position Module, 284
 - Motion Control wizard, 246
 - PTO/PWM, 125
 - Motion Profile, defining for EM 253 Position Module, 252
 - Motors, torque speed curve, typical, 248
 - Mounting
 - clearance requirements, 16
 - dimensions, 16
 - DIN rail, 16
 - panel, 16
 - Move byte immediate read instruction, 166
 - Move byte immediate write instruction, 166
 - Move byte instruction, 165
 - Move double word instruction, 165
 - Move instructions, example, 183
 - Move real instruction, 165
 - Move word instruction, 165
 - MPI cable, 4
 - MPI network
 - greater than 187.5 Kbaud, 214
 - less than 187.5 Kbaud, 214
 - MPI protocol, 212, 230
 - Multi-master PPI network, 213
 - Multiple-segment operation, initializing PTO, 135
 - Multiply instruction, 140
 - Multiply integer to double integer instruction (MUL), 142
 - example, 142
- ## N
- National standards, 338
 - Natural exponential instruction, 143
 - Natural logarithm instruction, 143
 - Navigation bar, 51
 - Negative Polarity, EM 253 Position Module, 247
 - Negative transition instruction, 66
 - Nesting, subroutines, 203
 - Network
 - addresses, 208
 - baud rate, 218
 - biasing cable, 220
 - building, 218
 - cable, 218, 219
 - calculating distances, 218
 - communications port, 219
 - communications setup, 208–219
 - complex, 231
 - complex PPI, 213
 - components, 218–221
 - configuration guidelines, 218
 - CP card, 220
 - device addresses, 211
 - gap update factor (GUF), 228
 - highest station address (HSA), 228
 - HMI devices, 221
 - isolation, 218
 - master devices, 208
 - modem, 226
 - MPI, greater than 187.5 Kbaud, 214
 - MPI, less than 187.5 Kbaud, 214
 - multi-master PPI, 213
 - optimizing performance, 228
 - PC/PCI cable, 220
 - PROFIBUS-DP, 215
 - repeaters, 218
 - sample configurations, 213, 214, 215
 - single-master PPI, 213
 - slave devices, 208
 - terminating cable, 220
 - token rotation time, 228
 - transmission rate, 218
 - Network read instruction, 74, 75
 - error codes, 75
 - example, 77
 - Network write instruction, 74, 75
 - error codes, 75
 - example, 77
 - Next instruction, 170
 - example, 171
 - Nippon Kaiji Kyokai (NK) Maritime Agency, 338
 - No operation instruction, 68
 - Noise rejection, input filter, 41
 - Non-fatal errors, 56
 - Normalizing, loop inputs, 149
 - NOT instruction, 66
 - Null modem adapter, 226

Number, representation, 29
 Numbers, representation, 24, 30
 Numeric instructions
 cosine, 143
 natural exponential, 143
 natural logarithm, 143
 sine, 143
 square root, 143
 tangent, 143
 Numeric paging, EM 241 Modem module, 290

O

Off-delay timer instruction (TOF), 196, 201
 example, 199
 On-delay timer instruction (TON), 196, 201
 example, 198
 OP3, OP7, OP17, order numbers, 423
 Opening, program editor, 9
 Operand ranges, 65
 Operation modes, CPU
 changing, 37
 Freeport protocol, 222
 status bits, 408
 Operator interfaces, order number, 423
 Operator stations, specifying, 48
 Optimizing, network performance, 228
 OR instruction, 163
 example, 164
 OR load instruction, 70
 Order, of interrupt events, 160
 Order numbers, 421
 CP 243-2, 393
 CPU modules, 340
 digital expansion module, 346
 analog expansion module, 351, 361
 input simulators, 398
 PC/PPI cable, 396
 Output block diagram
 EM 232, 358
 EM 235, 358
 Output configurations, editing default in Position Module,
 247
 Output data word format
 EM 232, 357
 EM 235, 357
 Output image register, 22
 Output immediate instruction, 68
 Output instruction, 68
 Output specifications
 analog expansion module, 352
 CPU modules, 342
 discrete expansion module, 347
 Outputs, 22
 configuring states, 40
 CPU module, 343
 discrete expansion module, 348
 EM 253 Position Module, 244
 instructions without, 55

Outputs and relays, 20

P

Paging, Modem module, 290
 Panel mounting, 16
 Parameters
 in subroutines, 203
 types for subroutines, 204
 Parity errors
 SMB3, 409
 SMB30 and SMB130, 85
 Password
 clearing, 45
 configuring, 44
 CPU functions, 44
 recovering lost, 45
 restricting access, 45
 Password protection, EM 241 Modem module, 291
 PC/PPI cable, 4, 6
 baud rate switch selections, 226, 397
 Freeport mode, 223
 order number, 396
 RS-232 standard, 223
 selecting, 220
 specifications, 396
 with modem, 226
 Peer-to-peer communications, 213-214
 Performance, optimizing network, 228
 Permanent program storage, 38
 Physical Inputs, response of EM 253 Position Module,
 248
 PID loop instruction, 145
 alarm checking, 151
 automatic mode, 151
 converting loop inputs, 149
 converting loop outputs to scaled integer, 150
 derivative term, 148
 error conditions, 151
 example, 153
 forward-acting, 150
 integral term, 147
 loop control, 148
 loop control types, 148
 loop table, 152
 manual mode, 151
 modes, 151
 normalizing loop inputs, 149
 program example, 152
 proportional term, 147
 ranges, 150
 reverse-acting, 150
 understanding, 146
 variables, 150
 wizard, 145
 Pin assignment, communications port, 219
 Pipelining, PTO pulses, 126
 PLC Information dialog box, 56
 Pointers, indirect addressing, 32

- Position module
 - ACCEL_TIME, 249
 - configuration, 275
 - Configuration/Profile table, 278
 - configuring, 246
 - creating instructions, 286
 - DECEL_TIME, 249
 - diagnostics information, 275
 - displaying and controlling operation, 274
 - eliminating backlash, 256
 - EM 253 Control Panel, 274–276
 - error codes, 276
 - Features, 244
 - Input Active Levels, 247
 - input and output configurations, 247
 - Input Filter Times, 247
 - inputs and outputs, 244
 - instruction error codes, 276
 - instruction guidelines, 257
 - instructions, 257
 - jerk time, 250
 - jog parameters, 249
 - MAX_SPEED, 248
 - measurement type, selecting, 246
 - module error codes, 277
 - motion commands, 284
 - Motion Control wizard, 246
 - motion profile, defining, 252
 - Negative Polarity, 247
 - Positive Polarity, 247
 - POSx_CFG, 268
 - POSx_CLR, 267
 - POSx_CTRL, 258
 - POSx_DIS, 266
 - POSx_GOTO, 260
 - POSx_LDOFF, 263
 - POSx_LDPOS, 264
 - POSx_MAN, 259
 - POSx_RSEEK, 262
 - POSx_RUN, 261
 - POSx_SRATE, 265
 - profile mode of operation, 252
 - profile steps, 253
 - profiles, 252
 - programming, 245
 - Pulse and Directional Outputs, 247
 - reference point, 250
 - reference point seek, 250
 - RP seek modes, 253–257
 - RP Seek Sequence, 251
 - sample program to control, 286
 - special memory, 281
 - SS_SPEED, 248
- Positive Polarity, EM 253 Position Module, 247
- Positive transition instruction, 66
- POSx_CFG, 268
- POSx_CLR, 267
- POSx_CTRL, 258
- POSx_DIS, 266
- POSx_GOTO, 260
- POSx_LDOFF, 263
- POSx_LDPOS, 264
- POSx_MAN, 259
- POSx_RSEEK, 262
- POSx_RUN, 261
- POSx_SRATE, 265
- Potentiometers, analog adjustment, 45
- Power flow, subroutine parameter, 204
- Power loss, retentive memory, 35, 41
- Power requirements, 15
 - calculating, 399, 401
 - CPU, 399
 - expansion module, 399
 - sample, 400
 - table for calculating, 401
- Power specifications, CPU modules, 341
- Power supply, 6, 15
- Power-on, memory retention, 35–37
- PPI communications, changing to Freeport mode, 80
- PPI protocol, 211, 230
 - complex network, 213
 - multi-master network, 213
 - single-master network, 213
- Preset value
 - changing in HSC, 123
 - setting for HSC, 118
- Priority
 - interrupt events, 160
 - interrupt routines, 159
- Process image register, 39
- Process-image input register (I), 25
- Process-image output register (Q), 25
- Processing, communication requests, 23
- PROFIBUS protocol, 212, 230
- PROFIBUS-DP
 - data consistency, 378
 - module (EM 277), 375
 - sample program, 383
 - standard communications, 374
- PROFIBUS-DP network
 - cable specifications, 218
 - pin assignments, 219
 - repeaters, 218
 - S7-315-2 and EM 277, 215
 - STEP 7-Micro/WIN and HMI, 215
- Profile mode of operation, EM 253 Position Module, 252
- Profile of motion description, EM 253 Position Module, 252
- Profile Steps, EM 253 Position Module, 253
- Profile table, EM 253 Position Module, 278
- Profile table values, PTO/PWM generators, 130

- Program
 - analog inputs, 22
 - basic elements, 49
 - compile errors, 56
 - copying to memory cartridge, 36
 - creating, 8
 - creating with STEP 7-Micro/WIN, 51
 - debugging features, 236
 - downloading, 11, 34
 - editing in RUN mode, 236
 - execution errors, 57
 - monitoring, 11
 - monitoring status, 238
 - PID example, 152
 - restoring from memory cartridge, 37
 - running, 11
 - saving, 11
 - sharing data with interrupt routines, 157
 - specifying number of scans, 240
 - status chart, 59
 - storage, 34–38
 - structuring, 49
 - subroutines, 50
 - uploading, 34
 - Program control instructions
 - basic program control, 168
 - conditional end, 168
 - for-next loop, 170
 - jump instructions, 172
 - sequence control relay (SCR), 173
 - stop, 168
 - watchdog reset, 168
 - Program editors, 51
 - conventions, 54
 - Function Block Diagram (FBD), 51
 - Ladder Logic (LAD), 51
 - opening, 9
 - selecting, 51
 - Statement List (STL), 51
 - Program, sample, controlling Position module, 286
 - Programming
 - EM 253 Position Module, 245
 - high-speed counters, 112
 - Programming cable, 4
 - Programming software, order numbers, 422
 - Proportional term, PID algorithm, 147
 - Protection circuit, 338
 - Protocol, communication
 - selecting, 211
 - user-defined, 222
 - Protocols, PROFIBUS-DP, 374
 - PTO/PWM functions, registers (WMB66 to SMB85), 415
 - PTO0, PTO1 Profile Definition Table (SMB166 to SMB185), 418
 - Pulse and Directional Outputs, EM 253 Position Module, 247
 - Pulse catch, 41
 - Pulse catch feature, 42
 - Pulse output instruction (PLS), 125
 - Pulse outputs
 - high-speed, 46
 - pulse output instruction (PLS), 125
 - pulse train output instruction (PTO), 125
 - pulse width modulation instruction (PWM), 125
 - Pulse timer instruction (TP), 201
 - Pulse train output instruction (PTO), 46, 125
 - changing cycle time, 134
 - changing cycle time and pulse count, 135
 - changing pulse count, 135
 - configuring with SM memory, 128
 - cycle time, 126
 - examples, 136, 138
 - initializing for multiple-segment operation, 135
 - initializing for single-segment operation, 134
 - Motion Control wizard, 125
 - multiple-segment pipelining, 126
 - profile table values, 130
 - single-segment pipelining, 126
 - stepper motor control, 130
 - understanding, 126
 - Pulse width modulation instruction (PWM), 46, 125
 - changing pulse width, 132
 - configuring with SM memory, 128
 - cycle time, 127
 - example, 132
 - initializing, 132
 - Motion Control wizard, 125
 - profile table values, 130
 - stepper motor control, 130
 - understanding, 127
 - update methods, 127
- ## Q
- Q memory, 25
 - Queue overflow (SMB4), 409
 - Queues, interrupt routines, 159
 - Quick reference information, 431
- ## R
- Rail
 - dimensions, 16
 - mounting, 16
 - Ranges, PID loop, 150
 - Read real-time clock instruction, 73
 - Reading data from inputs, 22, 23
 - Real math instructions, example, 141
 - Real number values, 24, 29
 - Real to ASCII instruction, 98
 - example, 99

- Real-time clock instructions, 73
 - Receive instruction, 79
 - break detection, 83
 - end character detection, 84
 - end conditions, 82
 - example, 86
 - Freeport mode, 79
 - idle line detection, 82
 - intercharacter timer, 84
 - maximum character count, 85
 - message timer, 84
 - parity errors, 85
 - receiving data, 80
 - SMB86 to SMB94, SMB186 to SMB194, 416
 - start character detection, 82
 - start conditions, 82
 - user termination, 85
 - Receiving data, 85
 - Recovering, lost password, 45
 - Reference point (RP), 250
 - RP seek
 - RP_APPR_DIR, 250
 - RP_FAST, 250
 - RP_SEEK_DIR, 250
 - RP_SLOW, 250
 - seek direction, 250
 - RP seek sequence, modes, 251
 - RP_OFFSET, 251
 - Reinstalling, terminal block connector, 17
 - Relays, 20
 - service life, 338
 - Remote address, setting for S7-200, 210
 - Removing
 - CPU module, 17
 - expansion module, 17
 - memory cartridge, 36
 - terminal block connector, 17
 - Repeaters
 - network, 218
 - order numbers, 422
 - Requirements, Modbus Slave Protocol, 330
 - Reset, high-speed counter, 116
 - Reset dominant bistable instruction, 72
 - Reset immediate instruction, 68
 - Reset instruction, 68
 - example, 68
 - Resolution, timer, 197, 198
 - Restarting, after fatal error, 57
 - Restoring
 - data from EEPROM, 35
 - program from memory cartridge, 37
 - Retentive bit memory, 35
 - Retentive memory, 41
 - Retentive on-delay timer instruction (TONR), 196
 - example, 200
 - Return from interrupt instruction, 155
 - Return from subroutine instruction, 203
 - example, 205
 - Reverse-acting loops, 150
 - RJ11 jack, EM 241 Modem module, 288, 386
 - Rotate instructions, 179
 - example, 180
 - types, 179
 - Rotate left byte instruction, 179
 - Rotate left double word instruction, 179
 - Rotate left word instruction, 179
 - Rotate right byte instruction, 179
 - Rotate right double word instruction, 179
 - Rotate right word instruction, 179
 - Round instruction, 94
 - RP Seek mode options, 253–257
 - EM 253 Position Module, 253–257
 - RS-232 standard
 - Freeport mode, 223
 - PC/PPI cable, 223
 - RS-485 standard, 219
 - RTD module (EM 231), 368
 - RUN mode, 11, 37
 - editing program, 236
 - Run-time errors, 57
 - Run-time programming, error codes, 405
 - Running, program, 11
- ## S
- S memory, 29
 - S7-200
 - accessing data, 24
 - accumulators, 27
 - addressing, 24
 - analog inputs (AI), 29
 - analog outputs (AQ), 29
 - as slave device, 208, 375
 - baud rates, 208, 209–211
 - bit memory area (M), 25
 - C memory, 26
 - communications, 208
 - communications processing, 40
 - connecting with STEP 7-Micro/WIN, 7
 - constant values, 30
 - counter memory area (C), 26
 - CPU modules, 2
 - dimensions, 2
 - downloading, 34
 - electromagnetic compatibility, 339
 - environmental conditions, 339
 - error codes, 404
 - error handling, 56
 - executing control logic, 22
 - expansion modules, 3
 - grounding guidelines, 19
 - hardware troubleshooting, 241
 - high-speed counters, 27
 - I memory, 25
 - installation guidelines, 14
 - installing, 15
 - interrupt routines, 157
 - L memory, 28
 - local memory area (L), 28
 - M memory, 25
 - memory, 24

- S7-200 (continued)
 - memory cartridge, 36
 - memory ranges, 64, 461
 - modem, 226
 - network address, 209–211
 - password protection, 44
 - power supply, 6
 - process image register, 39
 - process-image input register (I), 25
 - process-image output register (Q), 25
 - programming conventions, 55
 - pulse catch feature, 42
 - Q memory, 25
 - reading and writing data, 22
 - response to fatal error, 404
 - retentive memory, 41
 - RS-232 standard, 223
 - RUN mode, 11, 37
 - S memory, 29
 - sample network configurations, 213, 214, 215
 - saving data, 34
 - scan cycle, 22, 39
 - sequence control relay memory area (S), 29
 - SM memory, 28
 - special features, 39
 - special memory area (SM), 28
 - status chart, 239
 - STOP mode, 11, 37
 - supported interrupt routines, 158
 - system components, 2
 - T memory, 26
 - technical specifications, 339
 - timer memory area (T), 26
 - troubleshooting, 241
 - uploading, 34
 - V memory, 25
 - variable memory area (V), 25
 - wiring diagrams, 343–345
 - wiring guidelines, 19
- S7-200 system manual, order numbers, 422
- S7-300, sample network configurations, 214
- S7-400, sample network configurations, 214
- Safety circuits, designing, 48
- Sample program, 8
- Saving
 - bit memory (M) to EEPROM, 35
 - program, 11
 - S7-200 program data, 34
 - value to EEPROM, 413
 - variable memory (V) to EEPROM, 38
- Scaled integer, converting loop outputs, 150
- Scan cycle, 22
 - specifying number, 240
 - timers, 198
- Scan times: SMW22 to SMW26, 412
- Security, passwords, 44
- Security callback, EM 241 Modem module, 292
- Seek Parameters, EM 253 Position Module, 250
- Segment instruction, 95
 - example, 95
- Selecting
 - communication protocol, 211
 - CP card, 220
 - instruction sets, 53
 - PC/PPI cable, 220
 - program editor, 51
 - RTD DIP switches, 368–369
 - S7-200 operating mode, 37
 - thermocouple DIP switches, 364
- Sequence control relay end instruction, 173
- Sequence control relay instructions
 - conditional sequence control relay end, 173
 - convergence control, 176
 - divergence control, 176
 - example, 173
 - load sequence control relay, 173
 - restrictions, 173
 - sequence control relay end, 173
 - sequence control relay transition, 173
- Sequence control relay memory area (S), 29
- Sequence control relay transition instruction, 173
- Set dominant bistable instruction, 72
- Set immediate instruction, 68
- Set instruction, 68
 - example, 68
- Set port address instruction, 88
- Set real-time clock instruction, 73
- Setting
 - baud rate, 208
 - control byte (HSC), 118
 - current and preset values for HSC, 118
 - date, 73
 - remote address for S7-200, 210
 - time, 73
- Setting up
 - MM3 drive, 325
 - MM4 drive, 328
- Seven-segment display, 95
- Shift instructions
 - example, 180
 - types, 179
- Shift left byte instruction, 179
- Shift left double word instruction, 179
- Shift register bit instruction, 181
 - example, 182
- Shift right byte instruction, 179
- Shift right double word instruction, 179
- Shift right word instruction, 179
- Short Message Service, EM 241 Modem module, 290
- SIMATIC counter instructions
 - count down, 106
 - count up, 106
 - count up/down, 106
 - examples, 108
- SIMATIC instruction set, 53
- SIMATIC timer instructions, 196
 - example, 198, 199, 200
- Simulators, order numbers, 423
- Simulators, input, 398
- Sine instruction, 143

- Single-master PPI network, 213
- Single-segment operation
 - changing PTO cycle time, 134
 - changing PTO cycle time and pulse count, 135
 - changing PTO pulse count, 135
 - initializing PTO, 134
- Slave device, 208
 - EM 277 PROFIBUS-DP, 375
 - S7-200, 375
- SM memory, 28
 - Modbus Slave Protocol, 330
 - PTO/PWM operation, 128
- SM0.2 retentive data lost memory bit, 35
- SMB0: status bits, 408
- SMB1: status bits, 408
- SMB130: freeport control registers, 412
- SMB131 to SMB165: HSC3, HSC4, HSC5 register, 417
- SMB166 to SMB185: PTO0, PTO1 Profile Definition Table, 418
- SMB186 to SMB194: receive message control, 416
- SMB2: freeport receive character, 409
- SMB200 to SMB549: intelligent module status, 419
- SMB28, SMB29 analog adjustment, 45, 412
- SMB3: freeport parity error, 409
- SMB30 and SMB130: freeport control registers, 412
- SMB31 and SMW32: EEPROM write control, 413
- SMB34 and SMB35: timed interrupt registers, 413
- SMB36 to SMB65: HSC0, HSC1, HSC2 register, 413
- SMB4: queue overflow, 409
- SMB5: I/O status, 410
- SMB6: CPU ID register, 410
- SMB66 to SMB85: PTO/PWM registers, 415
- SMB7: reserved, 410
- SMB8 to SMB21: I/O module identification and error registers, 411
- SMB86 to SMB94, SMB186 to SMB194: receive message control, 416
- SMS, Modem module, 290
- SMW22 to SMW26: scan times, 412
- SMW98: expansion I/O bus errors, 417
- Software debugging, 235
- Special memory
 - EM 241 Modem module, 304
 - Modbus Slave Protocol, 330
- Special memory area (SM), 28
 - analog adjustment potentiometers, 45
- Special memory bits, 408–416
 - quick reference, 431
- Special memory bytes, EM 277 PROFIBUS-DP, 379
- Special memory locations, EM 253 Position Module, 281
- Specifications
 - analog expansion module, 351
 - CPU module, 340
 - discrete expansion module, 346
 - EM 231 RTD, 361
 - EM 231 thermocouple, 361
 - EM 241 modem, 385
 - EM 277 PROFIBUS-DP, 373
 - Micro PLC system, 48
 - PC/PPI cable, 396
- Square root instruction, 143
- SS_SPEED, EM 253 Position Module, 248
- Standard contact instruction, 66
- Standard conversion instructions, 92
- Standard DIN rail, 15
- Standards, national and international, 338
- Start, high-speed counter, 116
- Start character detection, 82
- Starting, STEP 7-Micro/WIN, 7
- Statement List. *See* STL Editor
- Status
 - displaying in LAD and FBD, 238
 - displaying in STL, 239
 - end of scan, 238
 - execution, 238
 - monitoring program, 238
- Status byte, high-speed counter, 119
- Status chart, 59
 - forcing values, 240
 - monitoring values, 239
- Status LEDs
 - EM 231 RTD, 370
 - EM 231 thermocouple, 365
 - EM 253 position module, 389
 - EM 277 PROFIBUS-DP, 374, 380
- STEP 7-Micro/WIN
 - as master device, 208
 - baud rate, 209–211
 - communication settings, 7
 - computer requirements, 3
 - connecting with S7-200, 7
 - CP card, 221
 - creating programs, 51
 - debugging tools, 235
 - equipment requirements, 3
 - installation, 4
 - instruction sets
 - IEC 1131-3, 53
 - selecting, 53
 - SIMATIC, 53
 - Interface for EM 241, 289
 - network address, 209–211
 - opening, 51
 - order numbers, 422
 - PC/PPI cable, 221
 - program editors, 51
 - programming package, 3
 - sample network configurations, 213–216
 - starting, 7
- STEP 7-Micro/WIN 32 Instruction Libraries, 422
- Stepper motor control, PTO/PWM generators, 130
- STL editor
 - description, 51
 - features, 51
- STL instructions
 - execution times, 425
 - quick reference, 435
- Stop instruction, 168
 - example, 169
- STOP mode, 11, 37
- Storing, S7-200 program data, 34

String instructions
 concatenate string, 184
 copy string, 184
 copy substring from string, 186
 find first character within string, 187
 find string within string, 187
 string length, 184

String length instruction, 184

Structuring, program, 49

Subroutine instructions
 call subroutine, 203
 conditional return from subroutine, 203
 example, 205

Subroutines
 calling from interrupt routines, 158
 data types, 204
 example, 49
 guidelines, 50
 nesting, 203
 parameter types, 204
 power flow parameter, 204
 with parameters, 203

Subtract instruction, 140

Suppression circuits, 20

Surge suppression, 20

Swap bytes instruction, 183
 example, 183

Symbol table, 58
 addressing, 58
 configure for Modbus, 331

Symbolic addressing, 58

Symbolic names, creating list, 49

Synchronous updates, PWM instruction, 127

System block, 50

System design, Micro PLC, 48

System support, for interrupt routines, 157

T

T memory, 26

Table find instruction, 193
 example, 195

Table instructions
 add to table, 189
 first-in-first-out, 190
 last-in-first-out, 190
 memory fill, 192
 table find, 193

Tangent instruction, 143

TD 200 text display unit
 order number, 423
 order number for manual, 422

Telephone line interface, international, EM 241 Modem module, 288

Teleservice, 289

Temperature ranges
 EM 231 RTD, 371–372
 EM 231 thermocouple, 366–367

Terminal block connector
 reinstalling, 17
 removing, 17

Terminating, network cable, 220

Text Message Format, EM 241 Modem module, 309

Text paging, EM 241 Modem module, 290

Thermocouple module (EM 231)
 basics, 363
 configuring, 363
 status indicators, 365
 temperature ranges, 366–367

Time, setting, 73

Time-based interrupts, 158

Time-of-Day (TOD) clock, 73

Timed interrupt queue, 159

Timed interrupt routine, example, 161

Timed interrupts, time interval registers (SMB34, SMB35), 413

Timer instructions
 IEC
 off-delay timer (TOF), 201
 on-delay timer (TON), 201
 pulse timer (TP), 201
 interrupts, 158
 SIMATIC
 off-delay timer (TOF), 196
 on-delay timer (TON), 196
 retentive on-delay timer (TONR), 196

Timer memory area (T), 26

Timer resolution, 197, 198

TOD clock, 73

Token rotation time, 228
 comparing, 230

Token-passing network, example, 229

Toolbars, 51

Torque Speeds, typical for motors, 248

TP-Designer for TP070, Version 1.0, 422

TP070 touch panel unit, 4
 order number for manual, 422
 order numbers, 423

Transition instructions, 66

Transmission rate, network, 218

Transmit instruction, 79
 example, 86
 Freeport mode, 79
 transmitting data, 80

Troubleshooting
 error codes, 404
 fatal errors, 57
 guide, 241
 non-fatal errors, 56
 S7-200 hardware, 241

Truncate instruction, 94

U

Unconditional inputs, 55

Up counter instruction, 109

Up/down counter instruction, 109

Updating, PWM waveform, 127

Uploading, program, 34

User Libraries, 60

User termination, 85

User-defined protocol, Freeport mode, 222

- USS protocol, requirements, 312
- USS protocol instructions
 - execution error codes, 323
 - guidelines for using, 314
 - sample program, 322
 - USS4_DRV_CTRL, 316
 - USS4_INIT, 315
 - USS4_RPM_x and USS4_WPM_x, 319, 320
- USS Protocol Library, controlling MicroMaster drives, 311
- USS4_DRV_CTRL instruction, 316
- USS4_INIT instruction, 315
- USS4_RPM_x instruction, 319, 320
- USS4_WPM_x instruction, 319, 320

V

- V memory, 25
 - assigning addresses, 58
 - restoring from EEPROM, 35
 - saving to EEPROM, 38
- Variable memory area (V), 25
- Variables
 - monitoring, 59
 - monitoring with status chart, 239
 - PID loop, 150
 - symbolic addressing, 58
- Viewing, errors, 56

W

- Watchdog reset instruction, 168
 - example, 169
- Wiring, 18, 19
- Wiring diagrams
 - analog expansion modules, 352
 - CPU inputs and outputs, 343
 - CPU modules, 343–345
 - discrete expansion modules, 349–350
 - EM 253 position module, 391–392
- Wizards
 - Modem Expansion, 294
 - Motion Control, 246
 - PID, 145
- Word access, 24
- Word consistency, PROFIBUS, 378
- Work zone location, EM 253 Position Module, 256

To

SIEMENS ENERGY & AUTOMATION INC
ATTN: TECHNICAL COMMUNICATIONS M/S 519
3000 BILL GARLAND ROAD
PO BOX 1255
JOHNSON CITY TN USA 37605-1255

From

Name: -----
Job Title: -----
Company Name: -----
Street: -----
City and State: -----
Country: -----
Telephone: -----

Please check any industry that applies to you:

- | | |
|---|---|
| <input type="checkbox"/> Automotive | <input type="checkbox"/> Pharmaceutical |
| <input type="checkbox"/> Chemical | <input type="checkbox"/> Plastic |
| <input type="checkbox"/> Electrical Machinery | <input type="checkbox"/> Pulp and Paper |
| <input type="checkbox"/> Food | <input type="checkbox"/> Textiles |
| <input type="checkbox"/> Instrument and Control | <input type="checkbox"/> Transportation |
| <input type="checkbox"/> Non-electrical Machinery | <input type="checkbox"/> Other _____ |
| <input type="checkbox"/> Petrochemical | |



S7-200 Memory Ranges and Features

Description	CPU 221	CPU 222	CPU 224	CPU 226	CPU 226XM
User program size	2 Kwords	2 Kwords	4 Kwords	4 Kwords	8 Kwords
User data size	1 Kwords	1 Kwords	2.5 Kwords	2.5 Kwords	5 Kwords
Process-image input register	I0.0 to I15.7	I0.0 to I15.7	I0.0 to I15.7	I0.0 to I15.7	I0.0 to I15.7
Process-image output register	Q0.0 to Q15.7	Q0.0 to Q15.7	Q0.0 to Q15.7	Q0.0 to Q15.7	Q0.0 to Q15.7
Analog inputs (read only)	--	AIW0 to AIW30	AIW0 to AIW62	AIW0 to AIW62	AIW0 to AIW62
Analog outputs (write only)	--	AQW0 to AQW30	AQW0 to AQW62	AQW0 to AQW62	AQW0 to AQW62
Variable memory (V)	VB0 to VB2047	VB0 to VB2047	VB0 to VB5119	VB0 to VB5119	VB0 to VB10239
Local memory (L) ¹	LB0 to LB63	LB0 to LB63	LB0 to LB63	LB0 to LB63	LB0 to LB63
Bit memory (M)	M0.0 to M31.7	M0.0 to M31.7	M0.0 to M31.7	M0.0 to M31.7	M0.0 to M31.7
Special Memory (SM) Read only	SM0.0 to SM179.7 SM0.0 to SM29.7	SM0.0 to SM299.7 SM0.0 to SM29.7	SM0.0 to SM549.7 SM0.0 to SM29.7	SM0.0 to SM549.7 SM0.0 to SM29.7	SM0.0 to SM549.7 SM0.0 to SM29.7
Timers	256 (T0 to T255)	256 (T0 to T255)	256 (T0 to T255)	256 (T0 to T255)	256 (T0 to T255)
Retentive on-delay	1 ms 10 ms 100 ms	T0, T64 T1 to T4, and T65 to T68 T5 to T31, and T69 to T95	T0, T64 T1 to T4, and T65 to T68 T5 to T31, and T69 to T95	T0, T64 T1 to T4, and T65 to T68 T5 to T31, and T69 to T95	T0, T64 T1 to T4, and T65 to T68 T5 to T31, and T69 to T95
On/Off delay	1 ms 10 ms 100 ms	T32, T96 T33 to T36, and T97 to T100 T37 to T63, and T101 to T255	T32, T96 T33 to T36, and T97 to T100 T37 to T63, and T101 to T255	T32, T96 T33 to T36, and T97 to T100 T37 to T63, and T101 to T255	T32, T96 T33 to T36, and T97 to T100 T37 to T63, and T101 to T255
Counters	C0 to C255	C0 to C255	C0 to C255	C0 to C255	C0 to C255
High-speed counter	HC0, HC3, HC4, and HC5	HC0, HC3, HC4, and HC5	HC0 to HC5	HC0 to HC5	HC0 to HC5
Sequential control relays (S)	S0.0 to S31.7	S0.0 to S31.7	S0.0 to S31.7	S0.0 to S31.7	S0.0 to S31.7
Accumulator registers	AC0 to AC3	AC0 to AC3	AC0 to AC3	AC0 to AC3	AC0 to AC3
Jumps/Labels	0 to 255	0 to 255	0 to 255	0 to 255	0 to 255
Call/Subroutine	0 to 63	0 to 63	0 to 63	0 to 63	0 to 127
Interrupt routines	0 to 127	0 to 127	0 to 127	0 to 127	0 to 127
Positive/negative transitions	256	256	256	256	256
PID loops	0 to 7	0 to 7	0 to 7	0 to 7	0 to 7
Port	Port 0	Port 0	Port 0	Port 0, Port 1	Port 0, Port 1

¹ LB60 to LB63 are reserved by STEP 7-Micro/WIN, version 3.0 or later.

STL	Page
=	68
+D	140
-D	140
*D	140
/D	140
+I	140
-I	140
=I	68
*I	140
/I	140
+R	140
-R	140
*R	140
/R	140
A	66
AB < =	89
AB =	89
AB >	89
AB<	89
AB > =	89
AB <>	89
AD <	89
AD < =	89
AD =	89
AD >	89
AD > =	89
AD <>	89
AENO	70
AI	66
ALD	70
AN	66
ANDB	163
ANDD	163
ANDW	163
ANI	66
AR=	89
AR <	89
AR<=	89
AR >	89
AR>=	89
AR <>	89
AS=	91
AS<>	91
ATCH	155
ATH	96
ATT	189
AW <	89
AW < =	89

STL	Page
AW=	89
AW >	89
AW > =	89
AW <>	89
BCDI	92
BIR	166
BIW	166
BMB	167
BMD	167
BMW	167
BTI	92
CALL	203
CFND	187
COS	143
CRET	203
CRETI	155
CSCRE	173
CTD	106
CTU	106
CTUD	106
DECB	144
DECD	144
DECO	105
DECW	144
DISI	155
DIV	142
DTA	96
DTCH	155
DTI	92
DTR	92
DTS	100
ED	66
ENCO	105
END	168
ENI	155
EU	66
EXP	143
FIFO	190
FILL	192
FND <	193
FND <>	193
FND =	193
FND >	193
FOR	170
GPA	88
HDEF	111
HSC	111
HTA	96

STL	Page
IBCD	92
INCB	144
INCD	144
INCW	144
INVB	162
INVD	162
INVW	162
ITA	96
ITB	92
ITD	92
ITS	100
JMP	172
LBL	172
LD	66
LDB <=	89
LDB =	89
LDB >=	89
LDB >	89
LDB <	89
LDB <>	89
LDD >=	89
LDD <	89
LDD <=	89
LDD =	89
LDD >	89
LDD <>	89
LDI	66
LDN	66
LDNI	66
LDR=	89
LDR <	89
LDR<=	89
LDR >	89
LDR>=	89
LDR <>	89
LDS	70
LDS=	91
LDS<>	91
LDW <=	89
LDW <	89
LDW =	89
LDW >	89
LDW >=	89
LDW <>	89
LIFO	190
LN	143
LPP	70
LPS	70

STL	Page
LRD	70
LSCR	173
MOVB	165
MOVD	165
MOVR	165
MOWW	165
MUL	142
NEXT	170
NETR	74
NETW	74
NOT	66
O	66
OB =	89
OB > =	89
OB >	89
OB <	89
OB < =	89
OB <>	89
OD <	89
OD < =	89
OD =	89
OD >	89
OD > =	89
OD <>	89
OI	66
OLD	70
ON	66
ONI	66
OR=	89
OR <	89
OR<=	89
OR >	89
OR >=	89
OR <>	89
ORB	163
ORD	163
ORW	163
OS=	91
OS<>	91
OW <	89
OW < =	89
OW =	89
OW >	89
OW > =	89
OW <>	89
PID	145
PLS	125
R	68

STL	Page
RCV	79
RI	68
RLB	179
RLD	179
RLW	179
ROUND	92
RRB	179
RRD	179
RRW	179
RTA	96
RTS	100
S	68
SCAT	184
SCPY	184
SCRE	173
SCRT	173
SEG	92
SFND	187
SHRB	181
SI	68
SIN	143
SLB	179
SLD	179
SLEN	184
SLW	179
SPA	88
SQRT	143
SRB	179
SRD	179
SRW	179
SSCPYP	186
STD	100
STI	100
STOP	168
STR	100
SWAP	183
TAN	143
TODR	73
TODW	73
TOF	196
TON	196
TONR	196
TRUNC	92
WDR	168
XMT	79
XORB	163
XORD	163
XORW	163