

Complex Functions Examples c-5

Laurent Series

Leif Mejlbro



Download free books at

bookboon.com

Leif Mejlbro

Complex Functions Examples c-5

Laurent Series

Complex Functions Examples c-5 – Laurent Series
© 2008 Leif Mejlbro & Ventus Publishing ApS
ISBN 978-87-7681-389-5

Contents

	Introduction	5
1.	Some theoretical background	6
2.	Laurent series	9
3.	Fourier series	46
4.	Laurent series solution of differential equations	49
5.	Isolated boundary points	83
6.	The conditions around the point at ∞	96

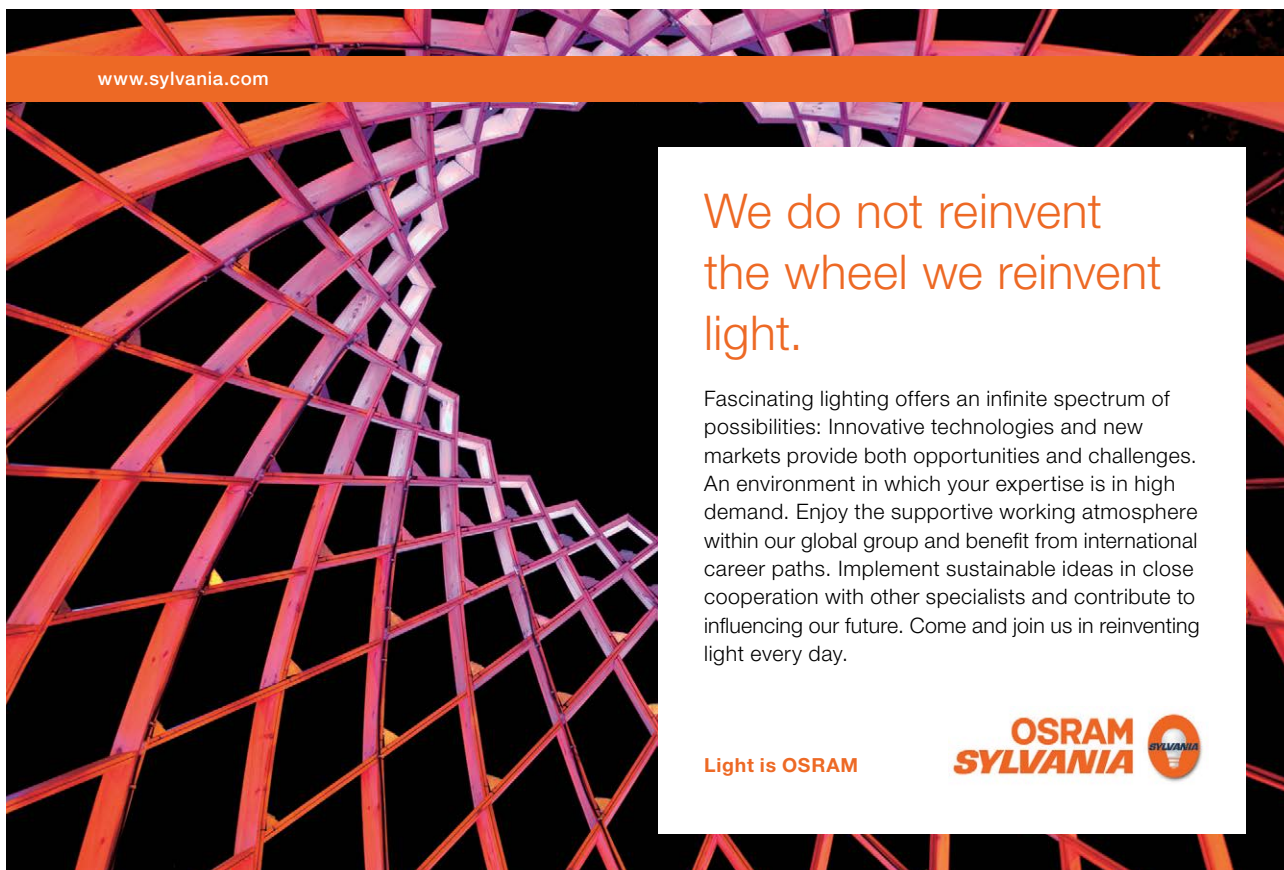

www.sylvania.com

**We do not reinvent
the wheel we reinvent
light.**

Fascinating lighting offers an infinite spectrum of possibilities: Innovative technologies and new markets provide both opportunities and challenges. An environment in which your expertise is in high demand. Enjoy the supportive working atmosphere within our global group and benefit from international career paths. Implement sustainable ideas in close cooperation with other specialists and contribute to influencing our future. Come and join us in reinventing light every day.

Light is OSRAM

**OSRAM
SYLVANIA** 

Introduction

This is the fifth book containing examples from the *Theory of Complex Functions*. In this volume we shall consider the Laurent series, which are, roughly speaking, complex power series in which we also allow negative exponents. We shall only consider the the series and their relationship to the general theory, and finally the technique of solving linear differential equations with polynomial coefficients by means of Laurent series. The importance of these Laurent series will be shown in the following books, where we first introduce the residues in the sixth book, and then examples of applications in the seventh book. Thus these three books, the present one and the two following, form together make up an important part of the *Theory of Complex Functions*.

Even if I have tried to be careful about this text, it is impossible to avoid errors, in particular in the first edition. It is my hope that the reader will show some understanding of my situation.

Leif Mejlbro
12th June 2008

1 Some theoretical background

Definition 1.1 We define a Laurent series expanded from the point $z_0 \in \mathbb{C}$ a series of the form

$$\sum_{n=-\infty}^{+\infty} a_n (z - z_0)^n := \sum_{n=0}^{+\infty} a_n (z - z_0)^n + \sum_{n=1}^{+\infty} a_{-n} (z - z_0)^{-n}.$$

The domain of convergence of the Laurent series is defined as the intersection of the domains of convergence of the series on the right hand side of the equation above.

If $a_{-n} = 0$ for every $n \in \mathbb{N}$, then the Laurent series is just an usual power series, which domain of convergence is of one of the following three types:

the empty set, an open disc of centrum z_0 , all of \mathbb{C} .

If there exists an $n \in \mathbb{N}$, such that $a_{-n} \neq 0$, then the domain of convergence is either

the empty set, or an annulus $\{z \in \mathbb{C} \mid r < |z - z_0| < R\}$.



Discover the truth at www.deloitte.ca/careers

Deloitte.

© Deloitte & Touche LLP and affiliated entities.



If $R = +\infty$, then the domain is the complementary set of a closed disc, and if $r = 0$, then the domain is either an open disc with its centrum removed, or the complex plan with z_0 removed, $\mathbb{C} \setminus \{z_0\}$. The Laurent series expansion of an analytic function $f(z)$ is always convergent in an annulus of centrum z_0 , where this annulus does not contain any singularity of $f(z)$, i.e. $f(z)$ is analytic in all of the annulus. The most important case, however, is when the inner radius is $r = 0$, i.e. when we consider a disc with only its centrum removed, or the complex plane with the point of expansion z_0 removed.

When we compute the coefficients of a Laurent series in an annulus we may use the following theorem, from which is also follows that if the annuli are as large as possible, given the point of expansion z_0 , then the Laurent series expansions are different in each of the possible annuli.

Theorem 1.1 LAURENT'S THEOREM. *Assume that $f(z)$ is analytic in an open annulus*

$$\{z \in \mathbb{C} \mid r < |z - z_0| < R\}.$$

Then the corresponding Laurent series in this annulus is uniquely determined by

$$f(z) = \sum_{n=-\infty}^{+\infty} a_n (z - z_0)^n,$$

where

$$a_n = \frac{1}{2\pi i} \oint_C \frac{f(z)}{(z - z_0)^{n+1}} dz, \quad \text{for every } n \in \mathbb{Z},$$

and where C is any simple, closed curve separating $|z - z_0| = r$ from $|z - z_0| = R$, run through in the positive sense of the plane.

The series is uniformly convergent in every closed and bounded subset of the annulus.

It was pointed out in *Complex Functions c-4* that the Laurent series may be used in the theory of Fourier series. However, the most important applications are connected with the so-called *Calculus of residues*, which we shall return to in *Complex Functions c-6* and to the specific application in *Complex Functions c-7*. In these cases in the next books we shall only consider the behaviour of the function in the neighbourhood of an isolated singularity of $f(z)$.

Assume that z_0 is an isolated singularity of the analytic function $f : \Omega \rightarrow \mathbb{C}$, i.e. there exists an $R > 0$, such that the disc with the centrum removed $B(z_0, R) \setminus \{z_0\} \subseteq \Omega$ is contained in Ω . Then we have some Laurent series expansion,

$$f(z) = \sum_{n=-\infty}^{+\infty} a_n (z - z_0)^n, \quad \text{for } z \in B(z_0, R) \setminus \{z_0\}.$$

There are here three possibilities:

- 1) If $a_n = 0$ for all negative n , then the Laurent series is an usual power series, and we can extend $f(z)$ analytically to z_0 . Therefore, we call this case a *removable singularity*.

Theorem 1.2 *If the analytic function $f(z)$ is bounded in a neighbourhood of z_0 (with the exception of z_0 itself), then z_0 is a removable singularity, and $f(z)$ is also bounded at z_0 .*

- 2) If $a_n \neq 0$ for some, though only a finite number of negative n , e.g. $a_{-N} \neq 0$ and $a_n = 0$ for every $n < -N$, then z_0 is called a *pole of order N* . In this case one sometimes write $f(z_0) = \infty$ (complex infinity).

Theorem 1.3 *If $f(z) \rightarrow \infty$ for $z \rightarrow z_0$, then $f(z)$ has a pole at z_0 .*

- 3) If $a_n \neq 0$ for infinitely many negative n , then z_0 is called an *essential singularitet* of $f(z)$. The function behaves really wildly in any neighbourhood of an essential singularity,

Theorem 1.4 PICARD'S THEOREM (1879). *If z_0 is an isolated essential singularity of the analytic function $f(z)$, and $D(r) := B(z_0, r) \setminus \{z_0\}$, $r > 0$, is any neighbourhood of z_0 (with the exception of z_0 itself), then the image $f(D(r))$ is either \mathbb{C} or \mathbb{C} with the exception of one point w_0 , i.e. $\mathbb{C} \setminus \{w_0\}$.*

Finally, we mention that there is no principal difference if we also consider ∞ as an isolated singularity. We must, however, in this case, request that the analytic function $f(z)$ is defined in the complementary set of a disc, $|z| > R$, where we always may choose $z_0 = 0$ as the point of expansion. Thus we assume that

$$f(z) = \sum_{n=-\infty}^{+\infty} a_n z^n, \quad \text{for } |z| > R.$$

Then we have the same three possibilities as above for a finite isolated singularity, though it here are the *positive* exponents which are causing troubles:

- 1) If $a_n = 0$ for every $n \in \mathbb{N}$, then ∞ is a *removable singularity* for $f(z)$. In this case we define by continuous expansion,

$$f(\infty) = a_0.$$

We note that we in connection with the \mathfrak{z} -transform always consider Laurent series of this type.

- 2) If $a_n \neq 0$ for some, though only finitely many $n \in \mathbb{N}$, e.g. $a_N \neq 0$ and $a_n = 0$ for every $n > N$, then we call ∞ a *pole* of $f(z)$ of order N .
- 3) Finally, if $a_n \neq 0$ for infinitely many $n \in \mathbb{N}$, we call ∞ an *essentiel singularity* of $f(z)$.

We should here add that e.g. $\sin z \neq 0$ for $z = n\pi$, $n \in \mathbb{Z}$, then $z = n\pi$, $n \in \mathbb{Z}$, are poles of $1/\sin z$. However, since $z = n\pi \rightarrow \infty$ for $n \rightarrow \pm\infty$, we see that ∞ is *not* an isolated singularity of $1/\sin z$, and it is not possible later on to speak about the residue at ∞ for such functions.

2 Laurent series

Example 2.1 Find the Laurent series expansions of the function

$$f(z) = \frac{1}{z-2}, \quad z \neq 2,$$

from $z_0 = 0$ in each of the domains in which there exists such an expansion.

The function is defined in $\mathbb{C} \setminus \{2\}$, and the point of expansion is $z_0 = 0$. Therefore, we have an usual Taylor expansion in the disc $|z| < 2$ and a Laurent series expansion in the complementary of a disc $|z| > 2$. The denominator consists of two terms, so the strategy is always to norm the numerically larger of the terms and then apply the usual geometric series expansion.

1) In the disc $|z| < 2$ the constant 2 is dominating in the denominator, and $\left|\frac{z}{2}\right| < 1$. Hence,

$$f(z) = \frac{1}{z-2} = -\frac{1}{2} \cdot \frac{1}{1-\frac{z}{2}} = -\frac{1}{2} \sum_{n=0}^{+\infty} \left\{\frac{z}{2}\right\}^n = -\sum_{n=0}^{+\infty} \frac{1}{2^{n+1}} z^n, \quad \text{for } |z| < 2,$$

which clearly is a Taylor series.

2) We have in the complementary of a disc, $|z| > 2$, that $\left|\frac{1}{z}\right| < 1$, so in this case we instead use that

$$f(z) = \frac{1}{z-2} = \frac{1}{z} \cdot \frac{1}{1-\frac{2}{z}} = \frac{1}{z} \sum_{n=0}^{+\infty} \left\{\frac{2}{z}\right\}^n = \sum_{n=1}^{+\infty} 2^{n-1} \cdot \frac{1}{z^n}, \quad \text{for } |z| > 2.$$

Summing up we get

$$f(z) = \frac{1}{z-2} = \begin{cases} -\sum_{n=0}^{+\infty} \frac{1}{2^{n+1}} z^n, & \text{for } |z| < 2, \\ \sum_{n=1}^{+\infty} 2^{n-1} \cdot \frac{1}{z^n}, & \text{for } |z| > 2. \end{cases}$$

Obviously, we cannot get any expansion when $|z| = 2$.

Example 2.2 Find the Laurent series expansions of the function

$$f(z) = \frac{1}{(z-1)(z-2)}, \quad z \in \mathbb{C} \setminus \{1, 2\},$$

from $z_0 = 0$ in each of the domains where such an expansion exists.

The singularities are 1 and 2, and the point of expansion is $z_0 = 0$. Thus, we get three domains, a disc $\Omega_1 = B(0, 1)$, and annulus $\Omega_2 = \{z \in \mathbb{C} \mid 1 < |z| < 2\}$, and finally a complementary set of a disc, $\Omega_3 = \{z \in \mathbb{C} \mid |z| > 2\}$. Since the function is a rational function, we start by a decomposition,

$$f(z) = \frac{1}{(z-1)(z-2)} = \frac{1}{z-2} - \frac{1}{z-1},$$

and then the most easy method is just to expand each fraction separately. We may here even use that the Laurent series of $\frac{1}{z-2}$ already have been found in Example 2.1, so we shall skip these computations.

1) If $z \in \Omega_1 = \{z \in \mathbb{C} \mid |z| < 1\}$, then we get the Taylor series

$$f(z) = \frac{1}{z-2} - \frac{1}{z-1} = -\frac{1}{2} \cdot \frac{1}{1-\frac{z}{2}} + \frac{1}{1-z} = \sum_{n=0}^{+\infty} \left\{1 - \frac{1}{2^{n+1}}\right\} z^n, \quad \text{for } |z| < 1.$$

We note that there are no negative exponents in this expansion.

2) If $z \in \Omega_2 = \{z \in \mathbb{C} \mid 1 < |z| < 2\}$, then we get the Laurent series

$$f(z) = \frac{1}{z-2} - \frac{1}{z-1} = -\frac{1}{2} \cdot \frac{1}{1-\frac{1}{2z}} - \frac{1}{z} \cdot \frac{1}{1-\frac{1}{z}} = -\sum_{n=0}^{+\infty} \frac{1}{2^{n+1}} z^{-n} - \sum_{n=1}^{+\infty} \frac{1}{z^n}.$$

We note that we have both positive and negative exponents in the Laurent series expansion.

SIMPLY CLEVER

ŠKODA



We will turn your CV into
an opportunity of a lifetime

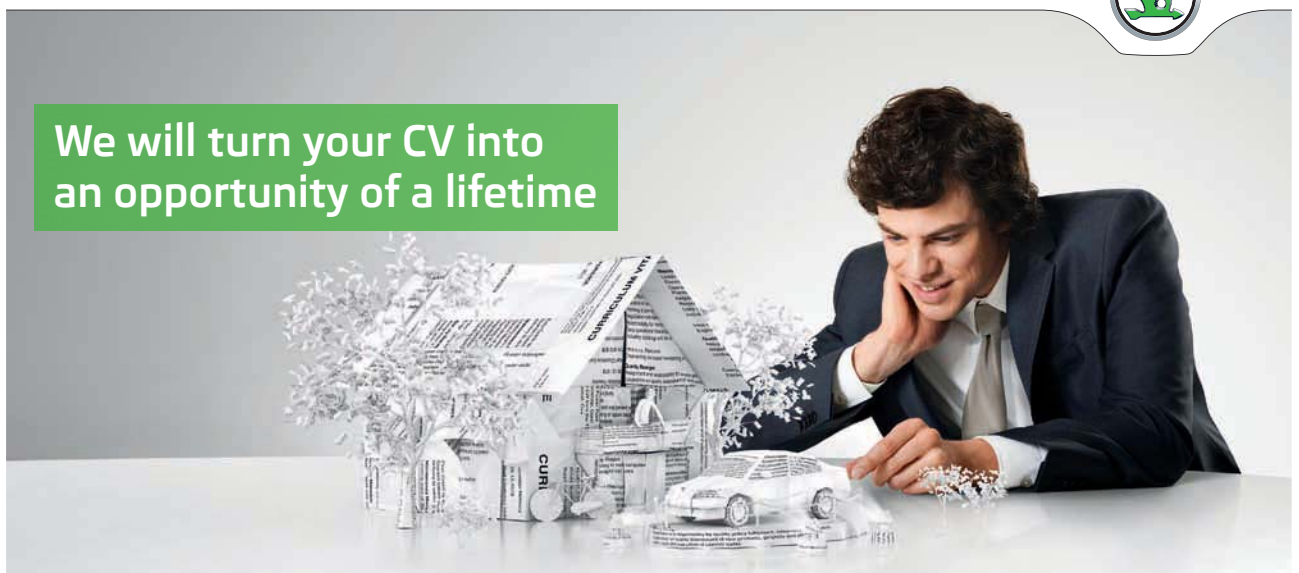

Do you like cars? Would you like to be a part of a successful brand?
We will appreciate and reward both your enthusiasm and talent.
Send us your CV. You will be surprised where it can take you.

Send us your CV on
www.employerforlife.com



Click on the ad to read more

3) If $z \in \Omega_3 = \{z \in \mathbb{C} \mid |z| > 2\}$, then we get the Laurent series

$$f(z) = \frac{1}{z-2} - \frac{1}{z-1} = \frac{1}{z} \cdot \frac{1}{1-\frac{2}{z}} - \frac{1}{z} \cdot \frac{1}{1-\frac{1}{z}} = \sum_{n=1}^{+\infty} \{2^{n-1} - 1\} \cdot \frac{1}{z^n} = \sum_{n=2}^{+\infty} \{2^{2-n} - 1\} \cdot \frac{1}{z^n}.$$

Note in this case that the series expansion does not contain any positive exponents.

Example 2.3 Find the Laurent series expansions of the function

$$f(z) = \frac{1}{(1-z)^2}, \quad z \neq 1,$$

from $z_0 = 0$ in each of the domains in which such an expansion exists.

The function $f(z)$ is analytic in the unit disc $\Omega_1 = B(0, 1)$ and in the complementary set $\Omega_2 = \mathbb{C} \setminus B[0, 1]$. Since $z = 1$ is a double pole, we first consider the following auxiliary function

$$g(z) := \frac{1}{1-z} = \begin{cases} \sum_{n=0}^{+\infty} z^n, & |z| < 1, \\ -\frac{1}{z} \cdot \frac{1}{1-\frac{1}{z}} = -\sum_{n=1}^{+\infty} \frac{1}{z^n}, & \text{for } |z| > 1. \end{cases}$$

Since $f(z) = g'(z)$ for $z \neq 1$, and since we may termwise differentiate the Laurent series in their domains, we easily get,

$$f(z) = \sum_{n=1}^{+\infty} n z^{n-1} = \sum_{n=0}^{+\infty} (n+1) z^n, \quad \text{for } z \in \Omega_1, \text{ dvs. for } |z| < 1,$$

and

$$f(z) = \sum_{n=1}^{+\infty} n \cdot z^{-n-1} = \sum_{n=2}^{+\infty} (n-1) z^{-n}, \quad \text{for } z \in \Omega_2, \text{ i.e. for } |z| > 1.$$

Obviously, this technique may be used in general on rational functions, whenever the denominator has a multiple root.

Example 2.4 Find the domain of convergence of each of the following series:

$$(a) \sum_{n=0}^{+\infty} \left(z^n + \frac{1}{2^n z^n} \right), \quad (b) \sum_{n=0}^{+\infty} \left(\frac{z^n}{n!} + \frac{n^2}{z^n} \right), \quad (c) \sum_{n=0}^{+\infty} \left(z^n + \frac{1}{z^n} \right).$$

(a) Here

$$\sum_{n=0}^{+\infty} z^n = \frac{1}{1-z} \quad \text{is convergent for } |z| < 1,$$

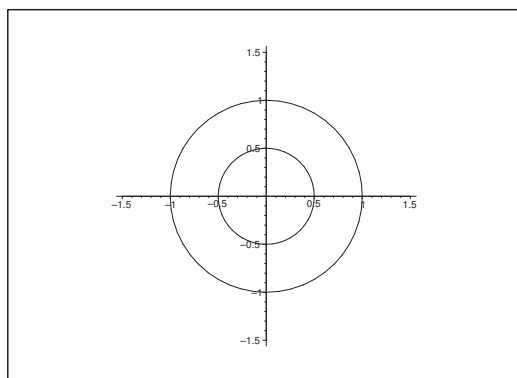
Figure 1: The domain in **(a)** is an annulus.

and

$$\sum_{n=0}^{+\infty} \frac{1}{2^n z^n} = \sum_{n=0}^{+\infty} \left(\frac{1}{2z}\right)^n = \frac{2z}{2z-1}$$

is convergent for $\left|\frac{1}{2z}\right| < 1$, thus for $|z| > \frac{1}{2}$. The common domain of convergence is the annulus

$$\{z \in \mathbb{C} \mid \frac{1}{2} < |z| < 1\},$$

and the sum function is

$$f(z) = \frac{1}{1-z} + \frac{2z}{2z-1}.$$

(b) The series

$$\sum_{n=0}^{+\infty} \frac{z^n}{n!} = e^z$$

is convergent for every $z \in \mathbb{C}$, and the series

$$\sum_{n=0}^{+\infty} \frac{n^2}{z^n} \quad \left(= \frac{z^2 + z}{(z-1)^2} \right)$$

is convergent for $\left|\frac{1}{z}\right| < 1$, thus for $|z| > 1$. The domain of convergence is the complementary set of a disc

$$\{z \in \mathbb{C} \mid |z| > 1\},$$

and the corresponding sum function is

$$f(z) = e^z + \frac{z^2 + z}{(z-1)^2}.$$

- (c) The series $\sum_{n=0}^{\infty} z^n$ has the domain of convergence $|z| < 1$, and the series $\sum_{n=0}^{\infty} \frac{1}{z^n}$ has the domain of convergence $|z| > 1$. The intersection is empty, so the open domain of convergence is also empty.

Remark 2.1 Additionally, we prove here that

$$\sum_{n=0}^{+\infty} \left(z^n + \frac{1}{z^n} \right)$$

is also divergent, when $|z| = 1$. We put on this circle, $z = e^{i\theta}$, so

$$z^n + \frac{1}{z^n} = e^{in\theta} + e^{-in\theta} = 2 \cos n\theta,$$

and the series is

$$\sum_{n=0}^{+\infty} \left(z^n + \frac{1}{z^n} \right) = 2 \sum_{n=0}^{+\infty} \cos n\theta, \quad z = e^{i\theta}.$$

We shall prove that the trigonometric series $\sum_{n=0}^{+\infty} \cos n\theta$ is *divergent* for every $\theta \in \mathbb{R}$. The *necessary condition* of convergence is that the n -th term tends towards 0, i.e. we require that

$$\cos n\theta \rightarrow 0 \quad \text{for } n \rightarrow +\infty.$$

Now, if e.g. $|\cos n\theta| < \frac{1}{2}$ for some n , then

$$|\cos 2n\theta| = |2 \cos^2 n\theta - 1| \geq 1 - 2 \cdot \frac{1}{4} = \frac{1}{2},$$

and it follows that $\cos n\theta$ does *not* tend towards 0 for $n \rightarrow +\infty$, so the series is divergent. \diamond

Example 2.5 Find the domain of convergence for each of the following series:

$$\begin{aligned} \text{(a)} \quad \sum_{n=1}^{\infty} \left\{ \frac{z(z+n)}{n} \right\}^n, & \quad \text{(b)} \quad \sum_{n=0}^{+\infty} \frac{(-1)^n}{z+n}, \\ \text{(c)} \quad \sum_{n=0}^{+\infty} \frac{2^n}{z^{2^n} + 1}, & \quad \text{(d)} \quad \sum_{n=0}^{+\infty} \frac{z^n}{1+z^{2^n}}. \end{aligned}$$

HINT: None of the series is a power series.

(a) It follows that

$$\left\{ \frac{z(z+n)}{n} \right\}^n = z^n \left(1 + \frac{z}{n} \right)^n,$$

where

$$\left(1 + \frac{z}{n} \right)^n \rightarrow e^z \quad \text{for } n \rightarrow +\infty.$$

In particular, to every z there exist constants C_1 and C_2 , as well as an N , such that

$$C_1|z|^n \leq \left| \left\{ \frac{z(z+n)}{n} \right\}^n \right| \leq C_2|z|^n \quad \text{for } n \geq N, .$$

Then we apply the *criterion of equivalence* for usual real series to conclude that the two series

$$\sum_{n=1}^{+\infty} \left\{ \frac{z(z+n)}{n} \right\}^n \quad \text{og} \quad \sum_{n=1}^{+\infty} z^n,$$

are absolutely convergent in the same domain, so the domain of convergence is the open unit disc

$$|z| < 1.$$

ASIDE. Note that if $|z| = 1$, then

$$\left| \frac{z(z+n)}{n} \right|^n \rightarrow |e^z| \neq 0,$$

and the *necessary condition* of convergence is *not* fulfilled, so the series is *divergent* on $|z| = 1$.

I joined MITAS because
I wanted **real responsibility**

The Graduate Programme
for Engineers and Geoscientists
www.discovermitas.com



Real work
International opportunities
Three work placements



Month 16
I was a construction
supervisor in
the North Sea
advising and
helping foremen
solve problems



(b) If $z \notin \mathbb{Z}_- \cup \{0\}$, then

$$\frac{(-1)^n}{z+n} = \frac{(-1)^n}{x+n+iy} = (-1)^n \cdot \frac{x+n-iy}{(x+n)^2+y^2}.$$

Clearly, the sum of the imaginary part alone is convergent for $z \notin \mathbb{Z}_- \cup \{0\}$, because the terms are asymptotically equal to a constant times $\frac{1}{n^2}$. Concerning the real parts we get for the numerical values,

$$\frac{x+n}{(x+n)^2+y^2} \searrow 0 \quad \text{for } n \rightarrow +\infty \text{ and } n \geq N(x).$$

The corresponding real sequence is *alternating*, hence it follows from *Dirichlet's criterion* that the real part of the series is also convergent. (A further analysis would of course show that the convergence of the real part is conditional, but we shall not use this fact here). The series is clearly not defined for $z \in \mathbb{Z}_- \cup \{0\}$, so the series is convergent for $z \notin \mathbb{Z}_- \cup \{0\}$.

(c) If $|z| \leq 1$, then of course,

$$\frac{2^n}{z^{2^n} + 1} \rightarrow \infty \quad \text{for } n \rightarrow +\infty,$$

and the series is divergent.

If instead $|z| > 1$, then

$$\frac{2^n}{z^{2^n} + 1} = \frac{2^n}{z^{2^n}} \cdot \frac{1}{1 + \frac{1}{z^{2^n}}} = \left(\frac{2}{z^{2^n/n}} \right)^n \cdot \{1 + o(1)\}.$$

It follows from

$$\frac{2}{z^{2^n/n}} \rightarrow 0 \quad \text{for } n \rightarrow +\infty \text{ og } |z| > 1,$$

that there exist a $k \in]0, 1[$ and an $N(k; z)$, such that

$$\left| \frac{2^n}{z^{2^n} + 1} \right| < k^n \quad \text{for alle } n \geq N(k; z).$$

(Note that the denominator is never 0, when $|z| > 1$). Hence, the domain of convergence is the complementary set of a disc $|z| > 1$.

(d) If $|z| = 1$, then

$$\left| \frac{z^n}{1 + z^{2^n}} \right| \geq \frac{1}{2} > 0,$$

and the necessary condition of convergence is not fulfilled, so the series is divergent for $|z| = 1$.

If $|z| < 1$, then we get the following estimates with some constants $C_1(z) > 0$ and $C_2(z) > 0$,

$$C_1(z) |z|^n \leq \left| \frac{z^n}{1 + z^{2^n}} \right| \leq C_2(z) |z|^n,$$

and since $\sum_{n=0}^{+\infty} z^n$ is convergent for $|z| < 1$, it follows from the *criterion of equivalence* that we have convergence for $|z| < 1$.

It $|z| > 1$, then z^{2^n} dominate, so we get instead the following estimate

$$\left| \frac{z^n}{1 + z^{2^n}} \right| \leq \frac{C}{|z|^{2^n - n}} \leq D \cdot \left(\frac{1}{|z|} \right)^n \quad n \geq N.$$

We conclude from $\frac{1}{|z|} < 1$ that the series is convergent.

Summing up we see that the domain of convergence is given by $|z| \neq 1$, i.e. in all points of \mathbb{C} , with the exception of the points of the unit circle.

Example 2.6 Find a strip $\{z \in \mathbb{C} \mid |y| < k\}$, in which the series

$$\sum_{n=1}^{+\infty} \frac{1}{2^n} \cos nz$$

is convergent. What is the largest possible k ?

Prove that the series defines an analytic function in the strip.

It follows formally from

$$\cos nz = \frac{1}{2} e^{inz} + \frac{1}{2} e^{-inz},$$

that

$$\sum_{n=1}^{+\infty} \frac{1}{2^n} \cos nz = \frac{1}{2} \sum_{n=1}^{+\infty} \frac{1}{2^n} e^{inz} + \frac{1}{2} \sum_{n=1}^{+\infty} \frac{1}{2^n} e^{-inz} = \frac{1}{2} \sum_{n=1}^{+\infty} \left(\frac{e^{iz}}{2} \right)^n + \frac{1}{2} \sum_{n=1}^{+\infty} \left(\frac{e^{-iz}}{2} \right)^n.$$

The former series is convergent when

$$\left| \frac{e^{iz}}{2} \right| < 1, \quad \text{i.e. when } e^{-y} < 2, \text{ or } y > -\ln 2,$$

and the latter series is convergent when

$$\left| \frac{e^{-iz}}{2} \right| < 1, \quad \text{i.e. when } e^y < 2, \text{ or } y < \ln 2.$$

Then obviously,

$$\sum_{n=1}^{+\infty} \frac{1}{2^n} \cos nz$$

is convergent for $|y| < \ln 2$ (and divergent for $|y| > \ln 2$). If $|y| < \ln 2$, then we get the sum function

$$\begin{aligned} \sum_{n=1}^{+\infty} \frac{1}{2^n} \cos nz &= \frac{1}{2} \sum_{n=1}^{+\infty} \left(\frac{e^{iz}}{2}\right)^n + \frac{1}{2} \sum_{n=1}^{+\infty} \left(\frac{1}{2e^{iz}}\right)^n = \frac{1}{2} \cdot \frac{\frac{e^{iz}}{2}}{1 - \frac{e^{iz}}{2}} + \frac{1}{2} \cdot \frac{\frac{1}{2e^{iz}}}{1 - \frac{1}{2e^{iz}}} \\ &= \frac{1}{2} \cdot \frac{e^{iz}}{2 - e^{iz}} + \frac{1}{2} \cdot \frac{e^{-iz}}{2 - e^{-iz}} = \frac{1}{2} \cdot \frac{2e^{iz} - 1 + 2e^{-iz} - 1}{4 - 2e^{iz} - 2e^{-iz} + 1} \\ &= \frac{1}{2} \cdot \frac{4 \cos z - 2}{5 - 4 \cos z} = \frac{2 \cos z - 1}{5 - 4 \cos z}, \quad |y| < \ln 2, \end{aligned}$$

and the function is clearly analytic in the strip.

Example 2.7 Prove that the series

$$\sum_{n=0}^{+\infty} \frac{z^{2n}}{1 - z^{2n+1}}$$

is convergent for every $z \in \mathbb{C}$, for which $|z| \neq 1$.

Find an expression of the sum of the series, partly in $\{z \mid |z| < 1\}$, and partly in $\{z \mid |z| > 1\}$.

If $|z| < 1$, then $|z|^m < \frac{1}{2}$ for $m \geq N = N(z)$, hence

$$\left| \frac{z^{2n}}{1 - z^{2n+1}} \right| \leq 2 \cdot |z^{2n}| \leq 2 \cdot |z|^n \quad \text{for } n \geq \frac{\ln N}{\ln 2}.$$

Since $\sum 2|z|^n$ is convergent for $|z| < 1$, it follows that

$$\sum_{n=0}^{+\infty} \frac{z^{2n}}{1 - z^{2n+1}}$$

is convergent for $|z| < 1$.

If instead $|z| > 1$, we write

$$\frac{z^{2n}}{1 - z^{2n+1}} = -\frac{\left(\frac{1}{z}\right)^{2n}}{1 - \left(\frac{1}{z}\right)^{2n+1}} = -\frac{z_1^{2n}}{1 - z_1^{2n+1}},$$

and since $\left|\frac{1}{z}\right| = |z_1| < 1$, it follows from the above that the series

$$\sum_{n=0}^{+\infty} \frac{z^{2n}}{1 - z^{2n+1}} = \sum_{n=0}^{+\infty} \frac{z_1^{2n}}{1 - z_1^{2n+1}}$$

is convergent for $|z_1| < 1$, i.e. for $|z| > 1$.

Finally, if $|z| = 1$, then

$$\left| \frac{z^{2^n}}{1 - z^{2^{n+1}}} \right| \geq \frac{1}{2} > 0,$$

and the necessary condition of convergence is not fulfilled, so we have divergence for $|z| = 1$.

Now,

$$\frac{w}{1 - w^2} = \frac{w(1 + w)}{(1 - w)(1 + w)} - \frac{w^2}{1 - w^2} = \frac{w}{1 - w} - \frac{w^2}{1 - w^2},$$

so if we put $w = z^{2^n}$, then

$$\frac{z^{2^n}}{1 - z^{2^{n+1}}} = \frac{z^{2^n}}{1 - z^{2^n}} - \frac{z^{2^{n+1}}}{1 - z^{2^{n+1}}},$$

ie business school

#1 EUROPEAN BUSINESS SCHOOL
FINANCIAL TIMES 2013

#gobeyond

MASTER IN MANAGEMENT

Because achieving your dreams is your greatest challenge. IE Business School's Master in Management taught in English, Spanish or bilingually, trains young high performance professionals at the beginning of their career through an innovative and stimulating program that will help them reach their full potential.

- Choose your area of specialization.
- Customize your master through the different options offered.
- Global Immersion Weeks in locations such as London, Silicon Valley or Shanghai.

Because you change, we change with you.

www.ie.edu/master-management | mim.admissions@ie.edu |



and the sectional sequence becomes

$$\begin{aligned} s_n(z) &= \frac{z}{1-z^2} + \frac{z^2}{1-z^4} + \cdots + \frac{z^{2^n}}{1-z^{2^{n+1}}} \\ &= \left(\frac{z}{1-z} - \frac{z^2}{1-z^2} \right) + \left(\frac{z^2}{1-z^2} - \frac{z^4}{1-z^4} \right) + \cdots + \left(\frac{z^{2^n}}{1-z^{2^n}} - \frac{z^{2^{n+1}}}{1-z^{2^{n+1}}} \right) \\ &= \frac{z}{1-z} - \frac{z^{2^{n+1}}}{1-z^{2^{n+1}}}. \end{aligned}$$

If $|z| < 1$, then the latter term tends towards 0 for $n \rightarrow +\infty$, hence

$$\sum_{n=0}^{+\infty} \frac{z^{2^n}}{1-z^{2^{n+1}}} = \lim_{n \rightarrow +\infty} s_n(z) = \frac{z}{1-z} \quad \text{for } |z| < 1.$$

If $|z| > 1$, then

$$-\frac{z^{2^{n+1}}}{1-z^{2^{n+1}}} = \frac{1}{1 - \left(\frac{1}{z}\right)^{2^{n+1}}} \rightarrow 1 \quad \text{for } n \rightarrow +\infty,$$

thus

$$\sum_{n=0}^{+\infty} \frac{z^{2^n}}{1-z^{2^{n+1}}} = \lim_{n \rightarrow +\infty} s_n(z) = \frac{z}{1-z} + 1 = \frac{1}{1-z} \quad \text{for } |z| > 1,$$

so summing up,

$$\sum_{n=0}^{+\infty} \frac{z^{2^n}}{1-z^{2^{n+1}}} = \begin{cases} \frac{z}{1-z} & \text{for } |z| < 1, \\ \frac{1}{1-z} & \text{for } |z| > 1. \end{cases}$$

Example 2.8 Prove that the power series

$$f(z) = \sum_{n=0}^{+\infty} z^{2^n}$$

represents a function, which is analytic in the disc $|z| < 1$, and which cannot be continuously extended across the unit circle.

HINT: Apply the equation

$$f(z) = z + z^2 + z^4 + \cdots + z^{2^{k-1}} + f(z^{2^k}).$$

Prove that if $\zeta \in \mathbb{C}$ satisfies $\zeta^{2^k} = 1$ for some $k \in \mathbb{N}$, then $f(t\zeta) \rightarrow \infty$ for $t \rightarrow 1-$.

Since $|z^{2^n}| \leq |z|^n$, whenever $|z| < 1$, it is obvious that $f(z)$ is analytic in the open disc $|z| < 1$.

Then

$$f(z) = z + z^2 + z^4 + \cdots + z^{2^{k-1}} + f(z^{2^k}).$$

If we choose $\zeta \in \mathbb{C}$, such that $\zeta^{2^k} = 1$, then

$$(t\zeta)^{2^k} = t^{2^k}, \quad t \in]0, 1[,$$

and we get

$$f((t\zeta)^{2^k}) = f(t^{2^k}) = \sum_{n=0}^{+\infty} (t^{2^k})^{2^n} = \sum_{n=0}^{+\infty} t^{2^{k+n}} \rightarrow +\infty \quad \text{for } t \rightarrow 1-,$$

where we have used that t is positive. Now

$$z + z^2 + \cdots + z^{2^{k-1}}$$

is bounded for $z = t\zeta$, so we conclude that

$$f(t\zeta) \rightarrow \infty \quad \text{for } t \rightarrow 1-.$$

Since this holds for every k , and since the set of 2^k -roots, $k \in \mathbb{N}_0$, are dense on the unit circle, we conclude that it is not possible to extend f continuously to any point on the unit circle $|z| = 1$.

Example 2.9 Find the Laurent series expansion from $z_0 = 0$ for each of the following functions in the given domains:

$$(a) \frac{z-1}{z+1} \quad \text{for } |z| > 1, \quad (b) \frac{10}{(z+2)(z^2+1)} \quad \text{for } 1 < |z| < 2.$$

(a) If $|z| > 1$ then it follows by an application of the geometric series that

$$\frac{z-1}{z+1} = \frac{1-\frac{1}{z}}{1+\frac{1}{z}} = -1 + \frac{2}{1+\frac{1}{z}} = -1 + 2 \sum_{n=0}^{+\infty} (-1)^n \left(\frac{1}{z}\right)^n = 1 + 2 \sum_{n=1}^{+\infty} (-1)^n \cdot \frac{1}{z^n}.$$

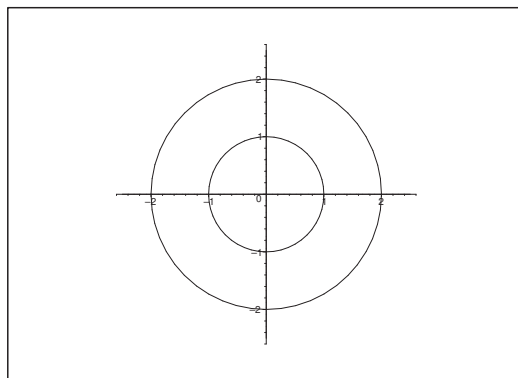
Figure 2: The annulus $1 < |z| < 2$.

(b) We decompose

$$\frac{10}{(z+2)(z^2+1)} = \frac{A}{z+2} + \frac{Bz+C}{z^2+1}.$$

Then

$$A = \frac{10}{5} = 2,$$

hence by reduction,

$$\frac{Bz+C}{z^2+1} = \frac{10}{(z+2)(z^2+1)} - \frac{2}{z+2} = \frac{10-2z^2-2}{(z+2)(z^2+1)} = -2 \frac{z^2-4}{(z+2)(z^2+1)} = \frac{-2z+4}{z^2+1}.$$

Since $1 < |z| < 2$, it follows by the geometric series that

$$\begin{aligned} \frac{10}{(z+2)(z^2+1)} &= \frac{2}{z+2} + \frac{-2z+4}{z^2+1} = \frac{1}{1+\frac{z}{2}} + \frac{-2 \cdot \frac{1}{z} + 4 \cdot \frac{1}{z^2}}{1+\left(\frac{1}{z}\right)^2} \\ &= \sum_{n=0}^{+\infty} (-1)^n \left(\frac{z}{2}\right)^n - \frac{2}{z} \sum_{n=0}^{+\infty} (-1)^n \cdot \frac{1}{z^{2n}} + \frac{4}{z^2} \sum_{n=0}^{+\infty} (-1)^n \cdot \frac{1}{z^{2n}} \\ &= \sum_{n=0}^{+\infty} \frac{(-2)^n}{2^n} z^n + \sum_{n=0}^{+\infty} \frac{2(-1)^{n+1}}{z^{2n+1}} + \sum_{n=1}^{+\infty} \frac{4(-1)^{n+1}}{z^{2n}}. \end{aligned}$$

Example 2.10 Find the Laurent series for $\frac{z+1}{z-1}$, in the disc $|z| < 1$, and in the complementary set of a disc $|z| > 1$.

(a) If $|z| < 1$, then by the geometric series

$$\frac{z+1}{z-1} = \frac{z-1+2}{z-1} = 1 - \frac{2}{1-z} = 1 - 2 \sum_{n=0}^{+\infty} z^n = -1 - 2 \sum_{n=1}^{+\infty} z^n, \quad |z| < 1.$$

(b) If $|z| > 1$, then put $w = \frac{1}{z}$, thus $|w| < 1$. It follows from (a) that

$$\frac{z+1}{z-1} = \frac{1+w}{1-w} = -\frac{w+1}{w-1} = 1 + 2 \sum_{n=1}^{+\infty} w^n = 1 + 2 \sum_{n=1}^{+\infty} \frac{1}{z^n}, \quad |z| > 1.$$

“ALTERNATIVELY”,

$$\frac{z+1}{z-1} = \frac{1+\frac{1}{z}}{1-\frac{1}{z}} = -1 + \frac{2}{1-\frac{1}{z}} = -1 + 2 \sum_{n=0}^{+\infty} \frac{1}{z^n} = 1 + 2 \sum_{n=1}^{+\infty} \frac{1}{z^n}, \quad |z| > 1.$$



no.1
nine years
in a row

Syeden
Stockholm

STUDY AT A TOP RANKED INTERNATIONAL BUSINESS SCHOOL

Reach your full potential at the Stockholm School of Economics, in one of the most innovative cities in the world. The School is ranked by the Financial Times as the number one business school in the Nordic and Baltic countries.

Visit us at www.hhs.se





Example 2.11 Find the Laurent series for

$$\frac{1}{z^2(1-z)}$$

in the sets $0 < |z| < 1$, and $|z| > 1$.

(a) If $0 < |z| < 1$, then

$$\frac{1}{z^2(1-z)} = \frac{1}{z^2} \sum_{n=0}^{+\infty} z^n = \sum_{n=-2}^{+\infty} z^n.$$

(b) If $|z| > 1$, then

$$\frac{1}{z^2(1-z)} = -\frac{1}{z^3} \cdot \frac{1}{1-\frac{1}{z}} = -\frac{1}{z^3} \sum_{n=0}^{+\infty} \frac{1}{z^n} = -\sum_{n=3}^{+\infty} \frac{1}{z^n}.$$

Example 2.12 Find the Laurent series expansion from 0 for each of the following functions in the given domains:

$$(a) \frac{z^2-1}{(z+2)(z+3)} \quad \text{for } |z| > 3, \quad (b) \frac{24}{z^2(z-1)(z+2)} \quad \text{for } 0 < |z| < 1.$$

(a) Since $\left|\frac{2}{z}\right| < 1$ and $\left|\frac{3}{z}\right| < 1$ for $|z| > 3$, we get by a decomposition (remember the constant term, because the numerator and the denominator have the same degree),

$$\begin{aligned} \frac{z^2-1}{(z+2)(z+3)} &= 1 + \frac{3}{z+2} - \frac{8}{z+3} = 1 + \frac{3}{z} \cdot \frac{1}{1+\frac{2}{z}} - \frac{8}{z} \cdot \frac{1}{1+\frac{3}{z}} \\ &= 1 + \frac{3}{z} \sum_{n=0}^{+\infty} (-1)^n \cdot \frac{2^n}{z^n} - \frac{8}{z} \sum_{n=0}^{+\infty} (-1)^n \cdot \frac{3^n}{z^n} \\ &= 1 + \sum_{n=1}^{+\infty} (-1)^{n-1} \cdot \frac{3 \cdot 2^{n-1}}{z^n} - \sum_{n=1}^{+\infty} (-1)^{n-1} \cdot \frac{8 \cdot 3^{n-1}}{z^n} \\ &= 1 + \sum_{n=1}^{+\infty} (-1)^n \{8 \cdot 3^{n-1} - 3 \cdot 2^{n-1}\} \cdot \frac{1}{z^n}. \end{aligned}$$

(b) Since $|z| < 1$ and $\left|\frac{z}{2}\right| < 1$ for $0 < |z| < 1$, it follows by a decomposition, in which $\frac{1}{z^2}$ does NOT

enter that

$$\begin{aligned} \frac{24}{z^2(z-1)(z+2)} &= \frac{1}{z^2} \left\{ \frac{8}{z-1} - \frac{8}{z+2} \right\} = -\frac{1}{z^2} \left\{ \frac{8}{1-z} + \frac{4}{1+\frac{z}{2}} \right\} \\ &= -\frac{1}{z^2} \left\{ \sum_{n=0}^{+\infty} 8z^n + \sum_{n=0}^{+\infty} (-1) \cdot 4 \cdot \frac{1}{2^n} z^n \right\} = -\sum_{n=0}^{+\infty} \left\{ 8 + (-1)^n \frac{4}{2^n} \right\} z^{n-2} \\ &= -\sum_{n=-2}^{+\infty} \left\{ 8 + (-1)^n \cdot \frac{4}{2^n} \right\} z^n. \end{aligned}$$

Example 2.13 Write the function

$$f(z) = \frac{z}{1+z^3}$$

in the form $\sum_{n=0}^{+\infty} a_n z^n$, as well as in the form $\sum_{n=0}^{+\infty} b_n \frac{1}{z^n}$. Indicate in both cases the domain of convergence.

It follows from $1+z^3=0$ that $|z|=1$. We shall therefore consider the cases $|z|<1$ and $|z|>1$ separately.

If $|z|<1$, then

$$\frac{z}{1+z^3} = z \sum_{n=0}^{+\infty} (-1)^n z^{3n} = \sum_{n=0}^{+\infty} (-1)^n z^{3n+1}, \quad |z|<1.$$

If instead $|z|>1$, then

$$\frac{z}{1+z^3} = \frac{1}{z^2} \cdot \frac{1}{1+\frac{1}{z^3}} = \frac{1}{z^2} \sum_{n=0}^{+\infty} (-1)^n \cdot \frac{1}{z^{3n}} = \sum_{n=0}^{+\infty} (-1)^n \cdot \frac{1}{z^{3n+2}}, \quad |z|>1.$$

Example 2.14 Find the Laurent series expansion from 0 of

$$(a) \frac{\sinh z}{z^8} \quad \text{for } |z|>0, \quad (b) \frac{\exp(z^2) - 1}{z^3} \quad \text{for } |z|>0.$$

(a) We get by using the series expansion of $\sinh z$ that

$$\frac{\sinh z}{z^8} = \frac{1}{z^8} \sum_{n=0}^{+\infty} \frac{z^{2n+1}}{(2n+1)!} = \sum_{n=0}^{+\infty} \frac{z^{2n-8+1}}{(2n+1)!} = \sum_{n=-4}^{+\infty} \frac{z^{2n+1}}{(2n+9)!}, \quad \text{for } z \in \mathbb{C} \setminus \{0\}.$$

(b) In the same way,

$$\frac{\exp(z^2) - 1}{z^3} = \frac{1}{z^3} \sum_{n=1}^{+\infty} \frac{z^{2n}}{n!} = \sum_{n=1}^{+\infty} \frac{z^{2n-3}}{n!} = \frac{1}{z} + \sum_{n=0}^{+\infty} \frac{z^{2n+1}}{(n+2)!}, \quad \text{for } z \in \mathbb{C} \setminus \{0\}.$$

Example 2.15 Find the Laurent series expansion from 0 of

$$(a) z^2 \exp\left(\frac{1}{z}\right), \quad (b) \exp\left(z + \frac{1}{z}\right), \quad (c) \sin z \cdot \sin \frac{1}{z}.$$

(a) We get by a series expansion

$$z^2 \exp\left(\frac{1}{z}\right) = z^2 \sum_{n=0}^{+\infty} \frac{1}{n!} z^{-n} = z^2 + z + \frac{1}{2} + \sum_{n=1}^{+\infty} \frac{1}{(n+2)!} z^n, \quad z \in \mathbb{C} \setminus \{0\}.$$

(b) Here we use *Cauchy multiplication*,

$$\begin{aligned} \exp\left(z + \frac{1}{z}\right) &= \exp z \cdot \exp \frac{1}{z} = \sum_{p=0}^{+\infty} \frac{z^p}{p!} \sum_{q=0}^{+\infty} \frac{1}{q!} z^{-q} \\ &= \sum_{p=0}^{+\infty} \sum_{q=0}^{+\infty} \frac{1}{p! q!} z^{p-q} = \sum_{n=-\infty}^{+\infty} a_n z^n, \quad z \in \mathbb{C} \setminus \{0\}, \end{aligned}$$

where it follows from the symmetry that $a_{-n} = a_n$. Furthermore,

$$a_n = \sum_{\substack{p, q=0 \\ p-q=n}}^{+\infty} \frac{1}{p! q!} = \sum_{q=0}^{+\infty} \frac{1}{q!(q+n)!}, \quad n \in \mathbb{N}_0,$$

hence

$$\exp\left(z + \frac{1}{z}\right) = \sum_{n=0}^{+\infty} \left\{ \sum_{q=0}^{+\infty} \frac{1}{q!(q+n)!} \right\} z^n + \sum_{n=1}^{+\infty} \left\{ \sum_{q=0}^{+\infty} \frac{1}{q!(q+n)!} \right\} \frac{1}{z^n}$$

for $z \in \mathbb{C} \setminus \{0\}$.

(c) We get by a *Cauchy multiplication* for $z \in \mathbb{C} \setminus \{0\}$ that

$$\sin z \cdot \sin \frac{1}{z} = \sum_{p=0}^{+\infty} \frac{(-1)^p}{(2p+1)!} z^{2p+1} \sum_{q=0}^{+\infty} \frac{(-1)^q}{(2q+1)!} \left(\frac{1}{z}\right)^{2q+1} = \sum_{p=0}^{+\infty} \sum_{q=0}^{+\infty} \frac{(-1)^{p-q}}{(2p+1)!(2q+1)!} z^{2(p-q)}.$$

The symmetry implies that $a_{-n} = a_n$, and it follows directly that $a_{2n+1} = 0$, $n \in \mathbb{Z}$. Finally,

$$a_{2n} = \sum_{\substack{p, q=0 \\ p-q=n}}^{+\infty} \frac{(-1)^{p-q}}{(2p+1)!(2q+1)!} = (-1)^n \sum_{q=0}^{+\infty} \frac{1}{(2q+1)!(2q+2n+1)!}$$

for $n \in \mathbb{N}_0$. Hence we get for $z \in \mathbb{C} \setminus \{0\}$,

$$\begin{aligned} \sin z \cdot \sin \frac{1}{z} &= \sum_{n=0}^{+\infty} (-1)^n \left\{ \sum_{q=0}^{+\infty} \frac{1}{(2q+1)!(2q+2n+1)!} \right\} z^{2n} \\ &\quad + \sum_{n=1}^{+\infty} \left\{ \sum_{q=0}^{+\infty} \frac{1}{(2q+1)!(2q+2n+1)!} \right\} \frac{1}{z^{2n}}. \end{aligned}$$

Example 2.16 Find the Laurent series expansion of the following functions,

$$(a) \frac{z}{z+2} \text{ for } |z| > 2, \quad (b) \sin \frac{1}{z} \text{ for } z \neq 0.$$

(a) Since $\left|\frac{2}{z}\right| < 1$ for $|z| > 2$, it follows by a division and an application of the geometric series,

$$\frac{z}{z+2} = \frac{1}{1 + \frac{2}{z}} = \sum_{n=0}^{+\infty} (-1)^n \cdot \frac{2^n}{z^n} \quad \text{for } |z| > 2.$$

(b) Here we get by the series expansion of $\sin w$, where we put $w = \frac{1}{z}$,

$$\sin \frac{1}{z} = \sum_{n=0}^{+\infty} \frac{(-1)^n}{(2n+1)!} \frac{1}{z^{2n+1}} \quad \text{for } z \neq 0.$$

#1
in eco-friendly
attitude

**STUDY AT
LINKÖPING UNIVERSITY, SWEDEN**
RANKED AMONG TOP 50 UNIVERSITIES UNDER 50

Interested in Strategy and Management in International Organisations? Kick-start your career with a master's degree from Linköping University, Sweden.

→ **Click here!**

 **Linköping University**

Example 2.17 Find the Laurent series expansion of the following functions:

$$(a) \cos \frac{1}{z} \quad \text{for } z \neq 0, \quad (b) \frac{1}{z-3} \quad \text{for } |z| > 3.$$

(a) Put $w = \frac{1}{z}$ into the series expansion of $\cos w$ to get

$$\cos \frac{1}{z} = \sum_{n=0}^{+\infty} \frac{(-1)^n}{(2n)!} \frac{1}{z^{2n}} \quad \text{for } z \neq 0.$$

(b) Since $\left| \frac{3}{z} \right| < 1$ for $|z| > 3$, it follows by a small rearrangement followed by an application of the geometric series that

$$\frac{1}{z-3} = \frac{1}{z} \cdot \frac{1}{1 - \frac{3}{z}} = \frac{1}{z} \sum_{n=0}^{+\infty} \frac{3^n}{z^n} = \sum_{n=1}^{+\infty} 3^{n-1} \frac{1}{z^n} \quad \text{for } |z| > 3.$$

Example 2.18 Find the first four terms of the Laurent series expansion of

$$f(z) = \frac{e^z}{z(z^2+1)}$$

in the set $0 < |z| < 1$.

If $0 < |z| < 1$, then

$$\frac{1}{z(z^2+1)} = \frac{1}{z} \sum_{n=0}^{+\infty} (-1)^n z^{2n} = \frac{1}{z} - z + z^3 - z^5 + \dots$$

Now,

$$e^z = 1 + z + \frac{z^2}{2!} + \frac{z^3}{3!} + \frac{z^4}{4!} + \dots,$$

so we get by a *Cauchy multiplication*,

$$\begin{aligned} \frac{e^z}{z(z^2+1)} &= \left\{ \frac{1}{z} - z + z^3 - z^5 + \dots \right\} \left\{ 1 + z + \frac{z^2}{2} + \frac{z^3}{6} + \frac{z^4}{24} + \dots \right\} \\ &= \frac{1}{z} + 1 + \left\{ \frac{1}{2} - 1 \right\} z + \left\{ \frac{1}{6} - 1 \right\} z^2 + \left\{ 124 - \frac{1}{2} + 1 \right\} z^3 + \dots \\ &= \frac{1}{z} - 1 - \frac{1}{2} z - \frac{5}{6} z^2 + \frac{13}{24} z^3 + \dots \end{aligned}$$

Example 2.19 Find the first four terms of the Laurent series expansion of $\frac{1}{\sin z}$ from 0.

Since $\sin z = 0$ for $z = 0$ and $z = \pi$, and since $\sin z \neq 0$ for $0 < |z| < \pi$, the domain of convergence is $0 < |z| < \pi$.

Since $\sin z$ is odd and has a zero of order 1 at 0, the structure must be

$$\frac{1}{\sin z} = \frac{a_{-1}}{z} + a_1 z + a_3 z^3 + a_5 z^5 + \dots$$

Now,

$$\sin z = z - \frac{z^3}{3!} + \frac{z^5}{5!} - \frac{z^7}{7!} + \dots,$$

so we get for $0 < |z| < \pi$,

$$\begin{aligned} 1 &= \sin z \cdot \frac{1}{\sin z} = \left\{ z - \frac{z^3}{3!} + \frac{z^5}{5!} - \frac{z^7}{7!} + \dots \right\} \left\{ \frac{a_{-1}}{z} + a_1 z + a_3 z^3 + a_5 z^5 + \dots \right\} \\ &= \left\{ 1 - \frac{z^2}{6} + \frac{z^4}{120} - \frac{z^6}{5040} + \dots \right\} \left\{ a_{-1} + a_1 z^2 + a_3 z^2 + a_5 z^6 + \dots \right\} \\ &= a_{-1} + \left\{ a_1 - \frac{1}{6} a_{-1} \right\} z^2 + \left\{ a_3 - \frac{1}{6} a_1 + \frac{1}{120} a_{-1} \right\} z^4 \\ &\quad + \left\{ a_5 - \frac{1}{6} a_3 + \frac{1}{120} a_1 - \frac{1}{5040} a_{-1} \right\} z^6 + \dots \end{aligned}$$

Then it follows from the identity theorem that

$$\begin{aligned} a_{-1} &= 1, \\ a_1 &= \frac{1}{6} a_{-1} = \frac{1}{6}, \\ a_3 &= \frac{1}{6} a_1 - \frac{1}{120} a_{-1} = \frac{1}{36} - \frac{1}{120} = \frac{7}{360}, \\ a_5 &= \frac{1}{6} a_3 - \frac{1}{120} a_1 + \frac{1}{5040} a_{-1} = \frac{7}{6 \cdot 360} - \frac{1}{6 \cdot 120} + \frac{1}{5040} = \frac{7-3}{6 \cdot 360} + \frac{1}{5040} \\ &= \frac{1}{180} \left\{ \frac{1}{3} + \frac{1}{28} \right\} = \frac{31}{3 \cdot 180 \cdot 28} = \frac{31}{15120}. \end{aligned}$$

Finally, by insertion,

$$\frac{1}{\sin z} = \frac{1}{z} + \frac{1}{6} z + \frac{7}{360} z^3 + \frac{31}{15120} z^5 + \dots, \quad 0 < |z| < \pi.$$

Example 2.20 Find the Laurent series expansions of the following functions:

$$(a) \frac{z}{z^2 - 1} \quad i \quad 1 < |z - 2| < 3, \quad (b) \frac{e^z}{z - 1} \quad i \quad |z| > 1.$$

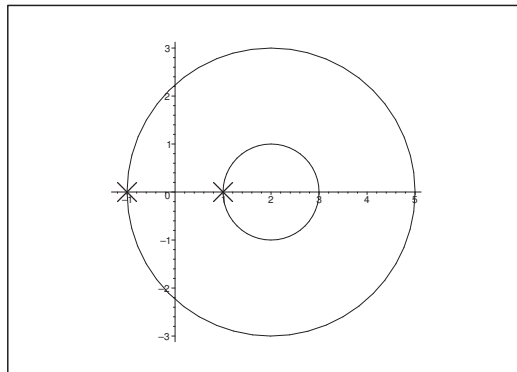

Figure 3: The annulus of centrum at $z = 2$, determined by the singularities $z = \pm 1$.

(a) The singular points are $z = \pm 1$, where the denominator is 0. Then apply a decomposition and change variable to $z - 2$,

$$\begin{aligned} \frac{z}{z^2 - 1} &= \frac{z}{(z - 1)(z + 1)} = \frac{1}{2} \cdot \frac{1}{z - 1} + \frac{1}{2} \cdot \frac{1}{z + 1} = \frac{1}{2} \cdot \frac{1}{z - 2} \cdot \frac{1}{\frac{1}{z - 2}} + \frac{1}{6} \cdot \frac{1}{1 + \frac{z - 2}{3}} \\ &= \frac{1}{2} \cdot \frac{1}{z - 2} \sum_{n=0}^{+\infty} \frac{(-1)^n}{(z - 2)^n} + \frac{1}{6} \sum_{n=0}^{+\infty} \frac{1}{3^n} (z - 2)^n \\ &= \sum_{n=0}^{+\infty} \frac{1}{6 \cdot 3^n} (z - 2)^n - \sum_{n=1}^{+\infty} \frac{(-1)^n}{2} \cdot \frac{1}{(z - 2)^n} \end{aligned}$$

for $1 < |z - 2| < 3$.

(b) If $|z| > 1$, then

$$\frac{1}{z - 1} = \frac{1}{z} \cdot \frac{1}{1 - \frac{1}{z}} = \sum_{n=1}^{+\infty} \frac{1}{z^n} \quad \text{og} \quad e^z = \sum_{n=0}^{+\infty} \frac{1}{n!} z^n,$$

so by a *Cauchy multiplication*,

$$\frac{e^z}{z - 1} = \sum_{p=0}^{+\infty} \frac{1}{p!} z^p \sum_{q=1}^{+\infty} \frac{1}{z^q} = \sum_{p=0}^{+\infty} \sum_{q=1}^{+\infty} \frac{1}{p!} z^{p-q} \quad \text{for } |z| > 1.$$

If we put $n = p - q \in \mathbb{Z}$, then $q = p - n \geq 1$, i.e. $p \geq n + 1$ and $p \geq 0$. Hence,

$$a_n = \sum_{p=n+1}^{+\infty} \frac{1}{p!} \quad \text{for } n > -1,$$

and

$$a_n = \sum_{p=0}^{+\infty} \frac{1}{p!} = e \quad \text{for } n \leq -1.$$

Finally, by insertion,

$$\frac{e^z}{z-1} = \sum_{n=1}^{+\infty} \frac{e}{z^n} + \sum_{n=0}^{+\infty} \left\{ \sum_{p=n+1}^{+\infty} \frac{1}{p!} \right\} z^n \quad \text{for } |z| > 1.$$



“I studied English for 16 years but...
...I finally learned to speak it in just six lessons”
Jane, Chinese architect

ENGLISH OUT THERE

Click to hear me talking before and after my unique course download

Example 2.21 Given the function f by

$$f(z) = \frac{5z}{6z^2 - z - 1}.$$

1) Find the largest annulus

$$R_1 < |z| < R_2, \quad \text{where } R_1 > 0 \text{ and } R_2 < +\infty,$$

in which f is analytic.

2) Find the power series from $z_0 = 0$ of f in the domain $|z| < R_1$.

3) Find the Laurent series from $z_0 = 0$ of f in the annulus $R_1 < |z| < R_2$.

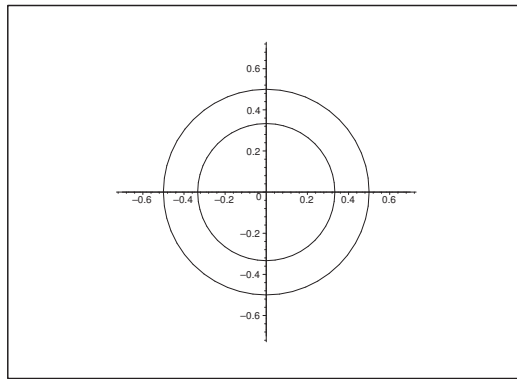

Figure 4: The open annular domain.

1) It follows from

$$6z^2 - z - 1 = 6 \left(z - \frac{1}{2} \right) \left(z + \frac{1}{3} \right),$$

that the singular points of the function are $-\frac{1}{3}$ and $\frac{1}{2}$. Consequently, $R_1 = \frac{1}{3}$ and $R_2 = \frac{1}{2}$, and the annulus becomes

$$\left\{ z \in \mathbb{C} \mid \frac{1}{3} < |z| < \frac{1}{2} \right\}.$$

2) If $|z| < R_1 = \frac{1}{3}$, then

$$\begin{aligned} f(z) &= \frac{5z}{6z^2 - z - 1} = \frac{5}{6} \cdot \frac{z}{\left(z - \frac{1}{2} \right) \left(z + \frac{1}{3} \right)} = \frac{5}{6} \cdot \frac{\frac{1}{2}}{\frac{1}{2} + \frac{1}{3}} \cdot \frac{1}{z - \frac{1}{2}} + \frac{5}{6} \cdot \frac{-\frac{1}{3}}{-\frac{1}{2} - \frac{1}{3}} \cdot \frac{1}{z + \frac{1}{3}} \\ &= \frac{1}{2z - 1} + \frac{1}{1 + 3z} = \frac{1}{1 + 3z} - \frac{1}{1 - 2z} = \sum_{n=0}^{+\infty} \{(-3)^n - 2^n\} z^n. \end{aligned}$$

3) If $\frac{1}{3} < |z| < \frac{1}{2}$, then

$$\begin{aligned} f(z) &= \frac{1}{2z-1} + \frac{1}{1+3z} = -\frac{1}{1-2z} + \frac{1}{3z} \cdot \frac{1}{1+\frac{1}{3z}} = -\sum_{n=0}^{+\infty} 2^n z^n + \frac{1}{3z} \sum_{n=0}^{+\infty} (-1)^n \cdot \frac{1}{3^n} \cdot \frac{1}{z^n} \\ &= -\sum_{n=0}^{+\infty} 2^n z^n + \sum_{n=1}^{+\infty} \frac{(-1)^{n-1}}{3^n} \cdot \frac{1}{z^n}. \end{aligned}$$

Example 2.22 Find for each of the annuli

(a) $0 < |z - z_0| < |z_0|$,

(b) $|z_0| < |z - z_0| < +\infty$,

the Laurent series of the function

$$f(z) = \frac{1}{z(z-2)}$$

from $z_0 = 2$. The result shall be given in one of the forms

(a) $f(z) = \sum_n a_n (z - z_0)^n$,

(b) $f(z) = \sum_n b_n (z - z_0)^n$.

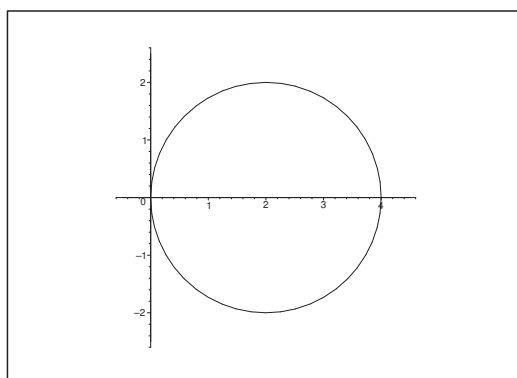

Figure 5: The limiting circle $|z - 2| = 2$.

(a) If $0 < |z - 2| < 2$, we put $w = \frac{z-2}{2}$. Then

$$0 < |w| < 1 \quad \text{and} \quad z = 2(w + 1),$$

and we get by the usual geometric series,

$$\begin{aligned} f(z) &= \frac{1}{z(z-2)} = \frac{1}{2(w+1) \cdot 2w} = \frac{1}{4w} \cdot \frac{1}{1+w} = \frac{1}{4w} \sum_{n=0}^{+\infty} (-1)^n w^n = \frac{1}{4} \sum_{n=-1}^{+\infty} (-1)^{n+1} w^n \\ &= \sum_{n=-1}^{+\infty} \frac{(-1)^{n+1}}{2^{n+2}} (z-2)^n \quad \text{for } 0 < |z-2| < 2. \end{aligned}$$

(b) If $2 < |z-2| < +\infty$, then $|w| > 1$, where $w = \frac{z-2}{2}$ as above. We get by the well-known trick,

$$\begin{aligned} f(z) &= \frac{1}{4w} \cdot \frac{1}{1+w} = \frac{1}{4w^2} \cdot \frac{1}{1+\frac{1}{w}} = \frac{1}{4w^2} \sum_{n=0}^{+\infty} \frac{(-1)^n}{w^n} = \sum_{n=2}^{+\infty} \frac{(-1)^n}{4w^n} \\ &= \sum_{n=2}^{+\infty} (-1)^n 2^{n-2} \frac{1}{(z-2)^n} \quad \text{for } 2 < |z-2| < +\infty. \end{aligned}$$

Example 2.23 Given the functions

$$f(z) = \frac{1}{1+z^2} \quad \text{and} \quad g(z) = \frac{1}{z^3(1+z^2)}.$$

- 1) Find the Taylor series of f with $z_0 = 0$ as point of expansion, and determine its coefficients. Find the radius of convergence R of the series.
- 2) Find the Laurent series of g from $z_0 = 0$ in the domain $0 < |z| < R$, and determine its coefficients.
- 3) Find the Laurent series of g from $z_0 = 0$ in the domain $|z| > R$, and determine its coefficients.

1) Clearly,

$$f(z) = \frac{1}{1+z^2} = \sum_{n=0}^{+\infty} (-1)^n z^{2n} \quad \text{for } |z| < 1,$$

thus $R = 1$. It follows that

$$a_{2n+1} = 0 \quad \text{and} \quad a_{2n} = (-1)^n \quad \text{for } n \in \mathbb{N}_0,$$

and $a_{2n} = 0$ otherwise.

2) The Laurent series of $g(z)$ in $0 < |z| < 1$ is according to (1) given by

$$g(z) = \frac{1}{z^3} f(z) = \sum_{n=0}^{+\infty} (-1)^n z^{2n-3}.$$

It follows that $a_{2n} = 0$ and

$$a_{2n-3} = (-1)^n \quad \text{for } n \in \mathbb{N}_0,$$

and $a_{2n-3} = 0$ otherwise.

3) If instead $|z| > 1$, then the Laurent series of $g(z)$ is given by

$$g(z) = \frac{1}{z^3(1+z^2)} = \frac{1}{z^5} \cdot \frac{1}{1+\frac{1}{z^2}} = \frac{1}{z^5} \sum_{n=0}^{+\infty} \frac{(-1)^n}{z^{2n}} = \sum_{n=0}^{+\infty} (-1)^n z^{-2n-5}, \quad \text{for } |z| > 1.$$

Here,

$$a_{-2n-5} = (-1)^n \quad \text{for } n \in \mathbb{N}_0,$$

and $a_m = 0$ for $m \notin \{-2n-5 \mid n \in \mathbb{N}_0\}$.

Excellent Economics and Business programmes at:



**university of
 groningen**



**“The perfect start
 of a successful,
 international career.”**

CLICK HERE
 to discover why both socially
 and academically the University
 of Groningen is one of the best
 places for a student to be

www.rug.nl/feb/education

Example 2.24 Given the functions

$$f(z) = \frac{e^z}{1+z} \quad \text{and} \quad g(z) = e^{z+1}.$$

1) Find the first five terms

$$a_0 + a_1z + a_2z^2 + a_3z^3 + a_4z^4$$

in the Taylor series of f with 0 as point of expansion.
Specify the radius of convergence of the Taylor series.

2) Find the Taylor series of g with $z_0 = -1$ as point of expansion.
Determine the Laurent series of f in $\mathbb{C} \setminus \{-1\}$.

1) The function $f(z) = \frac{e^z}{1+z}$ is analytic in $\mathbb{C} \setminus \{-1\}$, where -1 is a simple pole. Hence the Taylor series from 0 is convergent for $|z| < 1$, i.e. in the open unit disc.

The first five terms of the Taylor series are found by termwise multiplication,

$$\begin{aligned} f(z) &= \frac{e^z}{1+z} = a_0 + a_1z + a_2z^2 + a_3z^3 + a_4z^4 + \dots \\ &= \left\{ 1 + \frac{z}{1!} + \frac{z^2}{2!} + \frac{z^3}{3!} + \frac{z^4}{4!} + \dots \right\} \{1 - z + z^2 - z^3 + z^4 - \dots\} \\ &= 1 + (1-1)z + \left(\frac{1}{2} - 1 + 1\right)z^2 + \left(\frac{1}{6} - \frac{1}{2} + 1 - 1\right)z^3 + \left(\frac{1}{24} - \frac{1}{6} + \frac{1}{2} - 1 + 1\right)z^4 + \dots \\ &= 1 + \frac{1}{2}z^2 - \frac{1}{3}z^3 + \frac{3}{8}z^4 + \dots \end{aligned}$$

2) Since $g(z) = e^{z+1}$ is analytic in \mathbb{C} , and the point of expansion is -1 , we get

$$g(z) = e^{z+1} = \sum_{n=0}^{+\infty} \frac{1}{n!} (z+1)^n, \quad z \in \mathbb{C}.$$

When we shall find the Laurent series of f in $\mathbb{C} \setminus \{-1\}$, it is tacitly understood that $z_0 = -1$ is the point of expansion. We find

$$f(z) = \frac{e^z}{1+z} = \frac{1}{e} \cdot \frac{e^{z+1}}{z+1} = \frac{1}{e} \sum_{n=0}^{+\infty} \frac{1}{n!} (z+1)^{n-1} = \frac{1}{e} \cdot \frac{1}{z+1} + \sum_{n=0}^{+\infty} \frac{1}{e} \cdot \frac{1}{(n+1)!} (z+1)^n.$$

Example 2.25 Denote by c any complex number, and define for any fixed c a function f_c by

$$f_c(z) = \left(\frac{1}{z^2} + \frac{c}{z^4} \right) \sin z.$$

1) Determine in the domain $\mathbb{C} \setminus \{0\}$ the Laurent series

$$\sum_{n=1}^{+\infty} \frac{b_n}{z^n} + \sum_{n=0}^{+\infty} a_n z^n$$

for f_c .

Determine the coefficients b_n and a_n .

2) Find for any c the value of the integral

$$\oint_{|z|=1} f_c(z) dz.$$

3) Put $c = 6$. Explain why f_6 has a primitive in the domain $\mathbb{C} \setminus \{0\}$, and find the Laurent series of any primitive of f_6 .

4) Discuss if $c \neq 6$ why f_c does not have a primitive in $\mathbb{C} \setminus \{0\}$.

1) Inserting the series expansion of $\sin z$, we get for $z \neq 0$ that

$$\begin{aligned} f_c(z) &= \left(\frac{1}{z^2} + \frac{c}{z^4} \right) \sin z = \frac{1}{z^2} \sum_{n=0}^{+\infty} \frac{(-1)^n}{(2n+1)!} z^{2n+1} + \frac{c}{z^4} \sum_{n=0}^{+\infty} \frac{(-1)^n}{(2n+1)!} z^{2n+1} \\ &= \sum_{n=-1}^{+\infty} \frac{(-1)^{n+1}}{(2n+3)!} z^{2n+1} + \sum_{n=-2}^{+\infty} c \frac{(-1)^{n+2}}{(2n+5)!} z^{2n+1} \\ &= \frac{c}{z^3} + \left(1 - \frac{c}{3!} \right) \frac{1}{z} + \sum_{n=0}^{+\infty} (-1)^n \left\{ \frac{c}{(2n+5)!} - \frac{1}{(2n+3)!} \right\} z^{2n+1}. \end{aligned}$$

It follows that

$$b_1 = 1 - \frac{c}{3!}, \quad b_3 = c \quad \text{and} \quad b_n = 0 \quad \text{otherwise,}$$

and

$$a_{2n} = 0, \quad n \in \mathbb{N}_0, \quad a_{2n+1} = (-1)^n \left\{ \frac{c}{(2n+5)!} - \frac{1}{(2n+3)!} \right\}, \quad n \in \mathbb{N}_0.$$

2) Now f_c is analytic in $\mathbb{C} \setminus \{0\}$, so it follows from the residue theorem that

$$\oint_{|z|=1} f_c(z) dz = 2\pi i \operatorname{res}(f_c; 0) = 2\pi i \left(1 - \frac{c}{6} \right).$$

3) If $c = 6$, then

$$f_6(z) = \frac{6}{z^3} + \sum_{n=0}^{+\infty} \left\{ \frac{6}{(2n+5)!} - \frac{1}{(2n+3)!} \right\} z^{2n+1}, \quad z \neq 0.$$

If $z \neq 0$, then this clearly has the primitive

$$\begin{aligned} F_6(z) &= -\frac{3}{z^2} + \sum_{n=0}^{+\infty} \frac{(-1)^n}{2n+2} \left\{ \frac{6}{(2n+5)!} - \frac{1}{(2n+3)!} \right\} z^{2n+2} \\ &= -\frac{3}{z^2} + \sum_{n=1}^{+\infty} \frac{(-1)^{n-1}}{2n} \left\{ \frac{6}{(2n+3)!} - \frac{1}{(2n+1)!} \right\} z^{2n} \\ &= -\frac{3}{z^2} + \sum_{n=1}^{+\infty} \frac{(-1)^{n-1}}{2n} \cdot \frac{1}{(2n+3)!} \{6 - (2n+3)(2n+2)\} z^{2n} \\ &= -\frac{3}{z^2} + \sum_{n=1}^{+\infty} \frac{(-1)^{n-1}}{2n} \cdot \frac{1}{(2n+3)!} (-1)\{2n+3+2\}(2n) z^{2n} \\ &= -\frac{3}{z^2} + \sum_{n=1}^{+\infty} \frac{(-1)^n}{(2n+3)!} \cdot (2n+5) z^{2n}, \end{aligned}$$

where we may add any arbitrary constant.

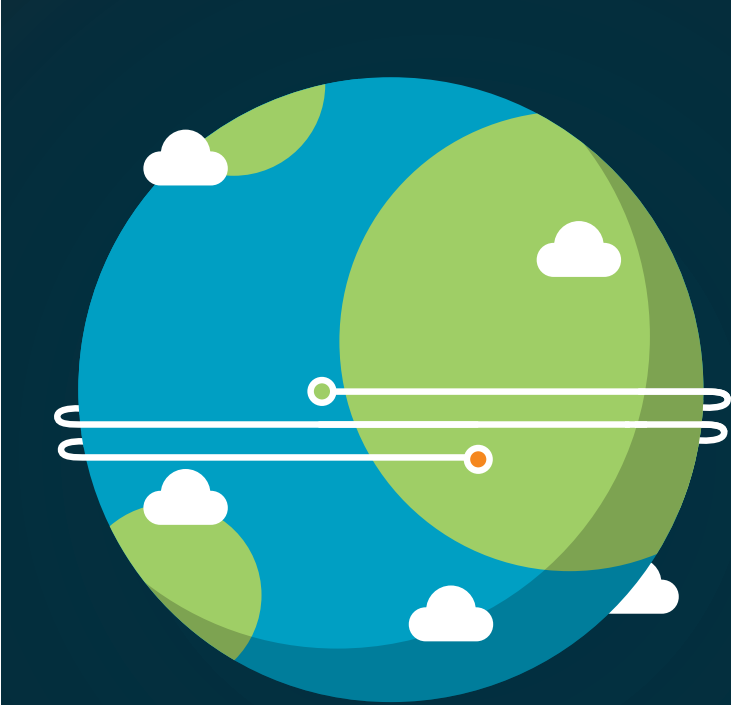

In the past four years we have drilled

89,000 km

That's more than **twice** around the world.

Who are we?
We are the world's largest oilfield services company¹. Working globally—often in remote and challenging locations—we invent, design, engineer, and apply technology to help our customers find and produce oil and gas safely.

Who are we looking for?
Every year, we need thousands of graduates to begin dynamic careers in the following domains:

- Engineering, Research and Operations
- Geoscience and Petrotechnical
- Commercial and Business

What will you be?

careers.slb.com

Schlumberger

¹Based on Fortune 500 ranking 2011. Copyright © 2015 Schlumberger. All rights reserved.



- 4) If $c \neq 6$, then the Laurent series contains a term of the type $\frac{c}{z}$, and it is well-known that this does not have any primitive in $\mathbb{C} \setminus \{0\}$.
A primitive is e.g. $\text{Log } z$, and this is only defined in the plane with a branch cut along the negative real axis, including 0.

Example 2.26 Given the function

$$f(z) = \frac{z+2}{1-z^2}.$$

- 1) Find the Taylor series $\sum_{n=0}^{+\infty} a_n z^n$ of f with the point of expansion $z_0 = 0$, and determine its coefficients.
Find also the radius of convergence R .
- 2) Find the Laurent series of f from the point $z_0 = 0$ in the domain $|z| > R$, and determine its coefficients.
- 3) Find the Laurent series of f in the largest possible annulus

$$0 < |z-1| < r.$$

Find its coefficients and the outer radius r .

- 1) The function

$$f(z) = \frac{z+2}{1-z^2}$$

has the poles ± 1 , so the radius of convergence (from $z_0 = 0$) is $R = 1$. For $|z| < 1$ we have the Taylor series

$$f(z) = (z+2) \cdot \frac{1}{1-z^2} = (z+2) \sum_{n=0}^{+\infty} z^{2n} = \sum_{n=0}^{+\infty} z^{2n+1} + \sum_{n=0}^{+\infty} 2z^{2n}, \quad |z| < 1.$$

By identification,

$$a_n = \begin{cases} 2 & \text{for } n \text{ even,} \\ 1 & \text{for } n \text{ odd,} \end{cases} \quad n \in \mathbb{N}_0.$$

- 2) If $|z| > 1$, then

$$\left| \frac{1}{z^2} \right| < 1,$$

and thus

$$f(z) = -\frac{z+2}{z^2} \cdot \frac{1}{1-\frac{1}{z^2}} = -\left(\frac{1}{z} + \frac{2}{z^2}\right) \sum_{n=0}^{+\infty} \frac{1}{z^{2n}} = -\sum_{n=0}^{+\infty} \frac{1}{z^{2n+1}} - \sum_{n=1}^{+\infty} \frac{2}{z^{2n}}, \quad |z| > 1.$$

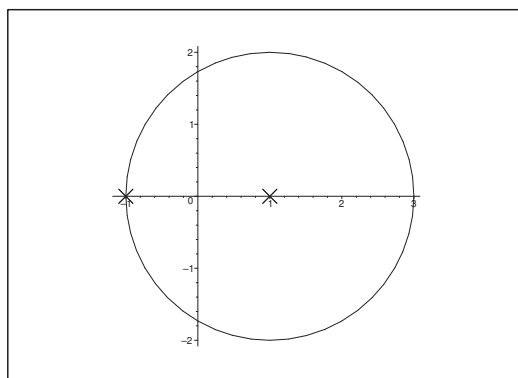
Figure 6: The disc $\{z \in \mathbb{C} \mid 0 < |z| < 2\}$ without its centrum.

It follows that

$$b_n = \begin{cases} -1 & \text{for } n \text{ odd,} \\ -2 & \text{for } n \text{ even,} \end{cases} \quad n \in \mathbb{N}.$$

- 3) The singularities are 1 and -1 , so $r = 2$. Putting $w = z - 1$, it follows for $0 < |w| = |z - 1| < 2$ that

$$0 < \left| \frac{w}{2} \right| < 1,$$

hence

$$\begin{aligned} f(z) &= \frac{z+2}{1-z^2} = -\frac{(z-1)+3}{(z-1)(z+1)} = -\frac{w+3}{w(w+2)} = -\frac{w+3}{2w} \cdot \frac{1}{1+\frac{w}{2}} \\ &= -\left\{ \frac{1}{2} + \frac{3}{2} \cdot \frac{1}{w} \right\} \sum_{n=0}^{+\infty} \frac{(-1)^n}{2^n} w^n = \sum_{n=0}^{+\infty} \frac{(-1)^{n+1}}{2^{n+1}} w^n + \sum_{n=0}^{+\infty} 3 \frac{(-1)^{n-1}}{2^{n+1}} w^{n-1} \\ &= \sum_{n=0}^{+\infty} \frac{(-1)^{n+1}}{2^{n+1}} w^n - \frac{3}{2} \cdot \frac{1}{w} + \sum_{n=0}^{+\infty} 3 \frac{(-1)^n}{2^{n+2}} w^n = -\frac{3}{2} \cdot \frac{1}{w} + \sum_{n=0}^{+\infty} (-1)^n \cdot \frac{1}{2^{n+2}} w^n \\ &= -\frac{3}{2} \cdot \frac{1}{2} z^{-1} - 1 + \sum_{n=0}^{+\infty} \frac{(-1)^n}{2^{n+2}} \cdot (z-1)^n, \quad 0 < |z-1| < 2, \end{aligned}$$

and thus

$$b_1 = -\frac{3}{2} \quad \text{and} \quad a_n = \frac{(-1)^n}{2^{n+2}}, \quad n \in \mathbb{N}_0.$$

Example 2.27 Given the function

$$f(z) = 2 - z^2 - 2 \cos z.$$

1) Find the Maclaurin series of f and its radius of convergence.
Determine the order of the zero of f at $z = 0$.

2) Then put

$$g(z) = f\left(\frac{1}{z}\right) \quad \text{for } z \neq 0.$$

Find the Laurent series of g in the set $|z| > 0$.
Determine the type of the singularities of g at $z = 0$.

3) Put

$$h(z) = \frac{1}{f(z)}.$$

Find the type of the singularity of h at $z = 0$.
Determine the coefficients a_{-j} for every $j > 0$ of the Laurent series of h ,

$$\sum_{j=1}^{+\infty} a_{-j} z^{-j} + \sum_{j=0}^{+\infty} a_j z^j$$

in a neighbourhood of $z = 0$, where $z \neq 0$.

1) The function $f(z)$ is analytic in \mathbb{C} , so the radius of convergence is $+\infty$.
By insertion of the power series of $\cos z$ we get

$$f(z) = 2 - z^2 - 2 \sum_{n=0}^{+\infty} \frac{(-1)^n}{(2n)!} z^{2n} = -2 \sum_{n=2}^{+\infty} \frac{(-1)^n}{(2n)!} z^{2n} = \sum_{n=2}^{+\infty} \frac{2(-1)^{n+1}}{(2n)!} z^{2n}.$$

It follows immediately that $f(z)$ has a zero of order 4 at $z = 0$.

2) If $z \neq 0$, it follows from (1) that the Laurent series of $g(z) = f\left(\frac{1}{z}\right)$ is

$$g(z) = \sum_{n=2}^{+\infty} \frac{2(-1)^{n+1}}{(2n)!} \frac{1}{z^{2n}}, \quad |z| > 0,$$

and it follows that $z = 0$ is an essential singularity.

3) Since $f(z)$ has a zero of order 4, the function $h(z) = \frac{1}{f(z)}$ has a pole of order 4 at 0. Hence,

$$h(z) = \frac{a_{-4}}{z^4} + \frac{a_{-3}}{z^3} + \frac{a_{-2}}{z^2} + \frac{a_{-1}}{z} + \sum_{j=0}^{+\infty} a_j z^j, \quad z \neq 0.$$

Since $f(z)$ is even, $h(z)$ is also even. This implies that $a_{-3} = a_{-1} = 0$ in the following expansion,

$$\begin{aligned} 1 &= f(z) \cdot h(z) \\ &= \left\{ -\frac{2}{4!} z^4 + \frac{2}{6!} z^6 - \frac{2}{8!} z^8 + \dots \right\} \left\{ \frac{a_{-4}}{z^4} + \frac{a_3}{z^3} + \frac{a_{-2}}{z^2} + \frac{a_{-1}}{z} + \dots \right\} \\ &= \left\{ -\frac{2}{4!} + \frac{2}{6!} z^2 - \frac{2}{8!} z^4 + \dots \right\} \{ a_{-4} + a_{-2} z^2 + \dots \} \\ &= -\frac{1}{12} a_{-4} + \left\{ \frac{2}{6!} a_{-4} - \frac{2}{4!} a_{-2} \right\} z^2 + \dots \end{aligned}$$

We get

$$a_{-4} = -12 \quad \text{and} \quad a_{-2} = \frac{2}{6!} \cdot \frac{4!}{2} a_{-4} = \frac{-12}{5 \cdot 6} = -\frac{2}{5}.$$

Summing up we get

$$a_{-4} = -12, \quad a_{-3} = 0, \quad a_{-2} = -\frac{2}{5}, \quad a_{-1} = 0.$$

American online

LIGS University

is currently enrolling in the
Interactive Online **BBA, MBA, MSc,**
DBA and PhD programs:

- ▶ enroll **by September 30th, 2014** and
- ▶ **save up to 16%** on the tuition!
- ▶ pay in 10 installments / 2 years
- ▶ Interactive **Online education**
- ▶ visit www.ligsuniversity.com to find out more!

Note: LIGS University is not accredited by any nationally recognized accrediting agency listed by the US Secretary of Education. More info [here](#).





Example 2.28 Given the functions

$$f(z) = \frac{1}{1-z} \quad \text{and} \quad g(z) = z^2 f''(z) + z f'(z).$$

1) Find the Maclaurin series of f .

Find also the Maclaurin series of g and the coefficients of this series.

2) Find the Laurent series of f in the annulus $|z| > 1$.

Also, find the Laurent series of g in the same annulus and the coefficients of this series.

3) Finally, find the Laurent series of g in the set defined by $|z - 1| > 0$.

1) The Maclaurin series of f is given by

$$f(z) = \sum_{n=0}^{+\infty} z^n, \quad |z| < 1.$$

Hence by termwise differentiation and insertion,

$$\begin{aligned} g(z) &= z^2 \sum_{n=2}^{+\infty} n(n-1)z^{n-2} + z \sum_{n=1}^{+\infty} n z^{n-1} = \sum_{\substack{n=2 \\ (n=0)}}^{+\infty} n(n-1)z^n + \sum_{\substack{n=1 \\ (n=0)}}^{+\infty} n z^n \\ &= \sum_{n=0}^{+\infty} n^2 z^n = \sum_{n=1}^{+\infty} n^2 z^n, \quad \text{for } |z| < 1. \end{aligned}$$

2) If $|z| > 1$, then

$$f(z) = \frac{1}{1-z} = \frac{1}{z} \cdot \frac{1}{1-\frac{1}{z}} = \frac{1}{z} \sum_{n=0}^{+\infty} \frac{1}{z^n} = \sum_{n=1}^{+\infty} \frac{1}{z^n} = \sum_{n=1}^{+\infty} z^{-n},$$

hence

$$f'(z) = - \sum_{n=1}^{+\infty} n z^{-n-1} \quad \text{and} \quad f''(z) = + \sum_{n=1}^{+\infty} n(n+1)z^{-n-2}, \quad |z| > 1,$$

thus

$$\begin{aligned} g(z) &= z^2 f''(z) + z f'(z) = \sum_{n=1}^{+\infty} n(n+1)z^{-n} - \sum_{n=1}^{+\infty} n z^{-n} \\ &= \sum_{n=1}^{+\infty} n^2 z^{-n} = \sum_{n=1}^{+\infty} \frac{n^2}{z^n} \quad \text{for } |z| > 1. \end{aligned}$$

3) If $z \neq 1$, then

$$f(z) = \frac{1}{1-z}, \quad f'(z) = \frac{1}{(1-z)^2}, \quad f''(z) = \frac{2}{(1-z)^3},$$

hence

$$\begin{aligned}
 g(z) &= z^2 f''(z) + z f'(z) = \frac{2z^2}{(1-z)^3} + \frac{z}{(1-z)^2} \\
 &= -\frac{2}{(z-1)^3} \{(z-1)+1\}^2 + \frac{z-1+1}{(z-1)^2} \\
 &= \frac{-2}{(z-1)^3} \{(z-1)^2 + 2(z-1) + 1\} + \frac{1}{(z-1)^2} + \frac{1}{z-1} \\
 &= -\frac{2}{z-1} - \frac{4}{(z-1)^2} - \frac{2}{(z-1)^3} + \frac{1}{(z-1)^2} + \frac{1}{z-1} \\
 &= -\frac{2}{(z-1)^3} - \frac{3}{(z-1)^2} - \frac{1}{z-1} \quad \text{for } |z-1| > 0,
 \end{aligned}$$

which we consider as a degenerated Laurent series from $z_1 = 1$ with only three terms.

Example 2.29 Given the function

$$f(z) = \frac{1}{z^2(z-4)}.$$

- 1) Find the Laurent series of f in the annulus $0 < |z| < 4$.
- 2) Find the Laurent series of f in the set $4 < |z|$.
- 3) Compute the integrals

$$\oint_{|z|=1} f(z) dz \quad \text{and} \quad \oint_{|z|=5} f(z) dz.$$

- 1) If $0 < |z| < 4$, then $\left|\frac{z}{4}\right| < 1$, hence

$$\begin{aligned}
 f(z) &= \frac{1}{z^2(z-4)} = -\frac{1}{4z^2} \cdot \frac{1}{1-\frac{z}{4}} = -\frac{1}{4z^2} \sum_{n=0}^{+\infty} \frac{z^n}{4^n} = \sum_{n=0}^{+\infty} \left(-\frac{1}{4^{n+1}}\right) z^{n-2} \\
 &= \sum_{n=-2}^{+\infty} \left(-\frac{1}{4^{n+3}}\right) z^n, \quad 0 < |z| < 4.
 \end{aligned}$$

- 2) If instead $|z| > 4$, then $\left|\frac{4}{z}\right| < 1$, hence

$$f(z) = \frac{1}{z^2(z-4)} = \frac{1}{z^3} \cdot \frac{1}{1-\frac{4}{z}} = \frac{1}{z^3} \sum_{n=0}^{+\infty} \frac{4^n}{z^n} = \sum_{n=3}^{+\infty} \frac{4^{n-3}}{z^n}.$$

- 3) The closed curve $|z| = 1$ lies in the annulus $0 < |z| < 4$, so if we apply the Laurent series from **(1)**, we get

$$\oint_{|z|=1} f(z) dz = 2\pi i a_{-1} = 2\pi i \cdot \left(-\frac{1}{4^2}\right) = -\frac{\pi i}{8}.$$

The closed curve $|z| = 5$ lies in the set $|z| > 4$, so if we apply the Laurent series from **(2)**, we get

$$\oint_{|z|=5} f(z) dz = 2\pi i \tilde{a}_{-1} = 0.$$

Example 2.30 Let c denote any complex number, and define the function f_c by

$$f_c(z) = \left(\frac{1}{z} - \frac{c}{z^2}\right) e^z.$$

- 1) Find the Laurent series $\sum_{-\infty}^{+\infty} a_j z^j$ of f_c in $\mathbb{C} \setminus \{0\}$, and determine the coefficients a_j for every j .
- 2) Explain why the Laurent series of f_c is uniformly convergent on the circle $|z| = 1$. Find for every constant c the value of the line integral

$$\oint_{|z|=1} f_c(z) dz.$$

- 3) Discuss, why f_c does not have a primitive in the set $\mathbb{C} \setminus \{0\}$, when $c \neq 1$.
- 4) Put $c = 1$. Prove that f_1 has a primitive in $\mathbb{C} \setminus \{0\}$. Find the Laurent series in $\mathbb{C} \setminus \{0\}$ of a primitive F_1 of f_1 .

- 1) If $z \neq 0$, then the Laurent series is given by

$$\begin{aligned} f_c(z) &= \left(\frac{1}{z} - \frac{c}{z^2}\right) e^z = \left(\frac{1}{z} - \frac{c}{z^2}\right) \sum_{n=0}^{+\infty} \frac{1}{n!} z^n = \sum_{n=0}^{+\infty} \frac{1}{n!} z^{n-1} - \sum_{n=0}^{+\infty} \frac{c}{n!} z^{n-2} \\ &= \sum_{n=-1}^{+\infty} \frac{1}{(n+1)!} z^n - \sum_{n=-2}^{+\infty} \frac{c}{(n+2)!} z^n = -\frac{c}{z^2} + \frac{1-c}{z} + \sum_{n=0}^{+\infty} \left\{ \frac{1}{(n+1)!} - \frac{c}{(n+2)!} \right\} z^n \\ &= -\frac{c}{z^2} + \frac{1-c}{z} + \sum_{n=0}^{+\infty} \frac{n+2-c}{(n+2)!} z^n. \end{aligned}$$

The coefficients are then

$$a_{-2} = -c, \quad a_{-1} = 1 - c,$$

and

$$a_n = \frac{1}{(n+1)!} - \frac{c}{(n+2)!}, \quad \text{for } n \geq 0.$$

2) We have the following estimate, when $|z| = 1$,

$$\begin{aligned} \left| -\frac{c}{z^2} + \frac{1-c}{z} + \sum_{n=0}^{+\infty} \left\{ \frac{1}{(n+1)!} - \frac{c}{(n+2)!} \right\} z^n \right| &\leq |c| + |1-c| + \sum_{n=0}^{+\infty} \frac{1}{n!} + |c| \sum_{n=0}^{+\infty} \frac{1}{n!} \\ &\leq |c| + |1-c| + (1+|c|)e < +\infty, \end{aligned}$$

proving that the Laurent series is uniformly convergent on $|z| = 1$.

We get by termwise integration,

$$\oint_{|z|=1} f_c(z) dz = 2i\pi a_{-1} = 2i\pi(1-c).$$

3) A *necessary* condition for f_c having a primitive is

$$\oint_{|z|=1} f_c(z) dz = 0.$$

When $c \neq 1$, we see that this condition is *not* fulfilled, so in this case a primitive does not exist in $\mathbb{C} \setminus \{0\}$.

4) If $c = 1$, then

$$f_1(z) = -\frac{1}{z^2} + \sum_{n=0}^{+\infty} \left\{ \frac{1}{(n+1)!} - \frac{1}{(n+2)!} \right\} z^n = -\frac{1}{z^2} + \sum_{n=0}^{+\infty} \left\{ \frac{n+1}{(n+2)!} \right\} z^n.$$

Here, $-\frac{1}{z^2}$ has the primitive $\frac{1}{z}$, and since the series

$$\varphi(z) = \sum_{n=0}^{+\infty} \frac{n+1}{(n+2)!} z^n$$

is analytic in \mathbb{C} , it follows that $\varphi(z)$ has a primitive, thus

$$f_1(z) = -\frac{1}{z^2} + \varphi(z), \quad z \in \mathbb{C} \setminus \{0\},$$

has a primitive. Then by termwise integration of the Laurent series expansion it follows that all primitives are given by

$$F_1(z) = \frac{1}{z} + k + \sum_{n=1}^{+\infty} \frac{1}{(n+1)!} z^n, \quad z \neq 0,$$

where $k \in \mathbb{C}$ is an arbitrary constant.

Remark 2.2 Here it is not hard to find an exact expression of the primitives $F_1(z)$, $z \neq 0$, by elementary functions. In fact,

$$\begin{aligned} F_1(z) &= \frac{1}{z} + k + \sum_{n=1}^{+\infty} \frac{1}{(n+1)!} z^n = k - 1 + \sum_{n=-1}^{+\infty} \frac{1}{(n+1)!} z^n = \\ &= k - 1 + \frac{e^z}{z}, \quad z \neq 0. \quad \diamond \end{aligned}$$

3 Fourier series

Example 3.1 Find the value of the integral

$$I(r) = \int_0^{2\pi} \frac{1 + r e^{it}}{1 - r e^{it}} dt \quad \text{for } r \neq 1.$$

HINT: Consider the function $f(z) = \frac{1+z}{1-z}$.

If $r = 0$, then

$$I(0) = \int_0^{2\pi} 1 dt = 2\pi.$$

Let $r \neq 0$ and $r \neq 1$. Denote by C the circle $|z| = r$ with positive direction (assuming that $r > 0$), so we have the parametric description

$$z = r e^{it} \quad \text{and} \quad dz = i r e^{it} dt.$$

.....Alcatel-Lucent 

www.alcatel-lucent.com/careers

What if you could build your future and create the future?

One generation's transformation is the next's status quo. In the near future, people may soon think it's strange that devices ever had to be "plugged in." To obtain that status, there needs to be "The Shift".



Then

$$\begin{aligned}\oint_C f(z) dz &= \oint_C \frac{1+z}{1-z} dz = \int_0^{2\pi} \frac{1+r e^{it}}{1-r e^{it}} \cdot i r e^{it} dt = -i \int_0^{2\pi} \frac{1+r e^{it}}{1-r e^{it}} (1-r e^{it}-1) dt \\ &= -i \int_0^{2\pi} (1+r e^{it}) dt + i \int_0^{2\pi} \frac{1+r e^{it}}{1-r e^{it}} dt.\end{aligned}$$

Then apply *Cauchy's integral theorem* and *Cauchy's integral formula* respectively,

$$\oint_C f(z) dz = \begin{cases} 0 & \text{for } r \in]0, 1[, \\ -4\pi i, & \text{for } r > 1. \end{cases}$$

Hence by a rearrangement and insertion,

$$\int_0^{2\pi} \frac{1+r e^{it}}{1-r e^{it}} dt = 2\pi + \frac{1}{i} \oint_C f(z) dz = \begin{cases} 2\pi & \text{for } r \in [0, 1[, \\ -2\pi & \text{for } r > 1. \end{cases}$$

We note that if $r < 0$, then due to the periodicity,

$$\int_0^{2\pi} \frac{1+r e^{it}}{1-r e^{it}} dt = \int_0^{2\pi} \frac{1-|r| e^{it}}{1+|r| e^{it}} dt = \int_0^{2\pi} \frac{1+|r| e^{i(t+\pi)}}{1-|r| e^{i(t+\pi)}} dt = \int_0^{2\pi} \frac{1+|r| e^{it}}{1-|r| e^{it}} dt.$$

Hence, $I(-r) = I(r)$, and we see that $I(r)$ is not defined for $r = \pm 1$, and that

$$I(r) = \int_0^{2\pi} \frac{1+r e^{it}}{1-r e^{it}} dt = \begin{cases} 2\pi & \text{for } |r| < 1, \\ -2\pi & \text{for } |r| > 1, \end{cases} \quad r \in \mathbb{R} \setminus \{-1, 1\}.$$

Example 3.2 Find the Laurent series of $\frac{1}{1-z}$, when $|z| > 1$. Then find the Fourier series of

$$\varphi(\theta) = \frac{1-r \cos \theta}{1+r^2-2r \cos \theta}, \quad \psi(\theta) = \frac{r \sin \theta}{1+r^2-2r \cos \theta}, \quad r > 1.$$

It follows from $|z| > 1$ that

$$\frac{1}{1-z} = -\frac{1}{z} \cdot \frac{1}{1-\frac{1}{z}} = -\frac{1}{z} \sum_{n=0}^{+\infty} \frac{1}{z^n} = -\sum_{n=1}^{+\infty} \frac{1}{z^n}, \quad |z| > 1.$$

Then put $z = r e^{i\theta}$, $r > 1$, to get

$$\frac{1}{1-z} = \frac{1}{1-r e^{i\theta}} = \frac{1-r \cos \theta + i r \sin \theta}{(1-r \cos \theta)^2 + (r \sin \theta)^2} = \frac{1-r \cos \theta + i \cdot r \sin \theta}{1+r^2-2r \cos \theta} = \varphi(\theta) + i \psi(\theta),$$

and

$$\frac{1}{1-z} = -\sum_{n=1}^{+\infty} \frac{1}{z^n} = -\sum_{n=1}^{+\infty} \frac{1}{r^n} e^{-in\theta} = -\sum_{n=1}^{+\infty} \frac{1}{r^n} \cos n\theta + i \sum_{n=1}^{+\infty} \frac{1}{r^n} \sin n\theta.$$

Finally, when we separate the real and the imaginary parts, we get

$$\varphi(\theta) = \frac{1 - r \cos \theta}{1 + r^2 - 2r \cos \theta} = - \sum_{n=1}^{+\infty} \frac{1}{r^n} \cos n\theta, \quad r > 1,$$

$$\psi(\theta) = \frac{r \sin \theta}{1 + r^2 - 2r \cos \theta} = \sum_{n=1}^{+\infty} \frac{1}{r^n} \sin n\theta, \quad r > 1.$$

Example 3.3 Prove for $0 < |z| < 4$ that

$$\frac{1}{4z - z^2} = \sum_{n=0}^{+\infty} \frac{z^{n-1}}{4^{n+1}}.$$

Then find the Fourier series of

$$(a) \frac{4 \cos \theta - \cos 2\theta}{17 - 8 \cos \theta}, \quad (b) \frac{\sin \theta - 4 \sin \theta}{17 - 8 \cos \theta}.$$

If $0 < |z| < 4$, then $0 < \left| \frac{z}{4} \right| < 1$, and we get by an application of the geometric series that

$$\frac{1}{4z - z^2} = \frac{1}{4z} \cdot \frac{1}{1 - \frac{z}{4}} = \frac{1}{4z} \sum_{n=0}^{+\infty} \frac{z^n}{4^n} = \sum_{n=0}^{+\infty} \frac{z^{n-1}}{4^{n+1}}.$$

If we put $z = e^{i\theta}$, then $|z| = 1 < 4$, and it follows by insertion and reduction that

$$\begin{aligned} \frac{1}{4z - z^2} &= \frac{1}{4e^{i\theta} - e^{2i\theta}} = \frac{4e^{-i\theta} - e^{-2i\theta}}{(4e^{i\theta} - e^{2i\theta})(4e^{-i\theta} - e^{-2i\theta})} = \frac{4 \cos \theta - \cos 2\theta + i(\sin 2\theta - 4 \sin \theta)}{16 + 1 - 4e^{i\theta} - 4e^{-i\theta}} \\ &= \frac{4 \cos \theta - \cos 2\theta}{17 - 8 \cos \theta} + i \frac{\sin 2\theta - 4 \sin \theta}{17 - 8 \cos \theta} = \sum_{n=0}^{+\infty} \frac{e^{i(n-1)\theta}}{4^{n+1}} = \sum_{n=0}^{+\infty} \frac{\cos(n-1)\theta}{4^{n+1}} + i \sum_{n=0}^{+\infty} \frac{\sin(n-1)\theta}{4^{n+1}}. \end{aligned}$$

Finally, when we separate the real and the imaginary parts,

(a) *Real part.*

$$\frac{4 \cos \theta - \cos 2\theta}{17 - 8 \cos \theta} = \sum_{n=0}^{+\infty} \frac{\cos(n-1)\theta}{4^{n+1}} = \frac{1}{16} + \frac{17}{64} \cos \theta + \sum_{n=2}^{+\infty} \frac{1}{4^{n+2}} \cos n\theta.$$

(b) *Imaginary part.*

$$\frac{\sin 2\theta - 4 \sin \theta}{17 - 8 \cos \theta} = \sum_{n=0}^{+\infty} \frac{(n-1)\theta}{4^{n+1}} = -\frac{15}{64} \sin \theta + \sum_{n=2}^{+\infty} \frac{1}{4^{n+2}} \sin n\theta.$$

4 Laurent series solution of differential equations

Example 4.1 Find all Laurent series from 0, which are a solution of the differential equation

$$z^3 f'(z) + f(z) = 0,$$

and determine its domain of convergence.

Remark 4.1 It is actually possible to solve the equation by inspection. However, since the trick is far from evident, we shall here start with the standard solution. \diamond

Laurent series solution. Since $z_0 = 0$ is a singular point of the differential equation, we can *at most* expect a Laurent series solution (possibly non at all). When we put the formal series

$$f(z) = \sum_{n=-\infty}^{+\infty} a_n z^n = \sum_{n=0}^{+\infty} a_n z^n + \sum_{n=1}^{+\infty} a_{-n} z^{-n},$$

into the differential equation, we get

$$\begin{aligned} 0 &= z^3 f'(z) + f(z) = z^3 \sum_{n=0}^{+\infty} n a_n z^{n-1} + \sum_{n=0}^{+\infty} a_n z^n = \sum_{n=0}^{+\infty} n a_n z^{n+2} + \sum_{n=0}^{+\infty} a_n z^n \\ &= \sum_{n=0}^{+\infty} n a_n z^{n+2} + \sum_{n=2}^{+\infty} a_{n+2} z^{n+2} = \sum_{n=2}^{+\infty} \{n a_n + a_{n+2}\} z^{n+2}. \end{aligned}$$

According to the *identity theorem* this equation is satisfied, if and only if the following recursion formula holds

$$n a_n + a_{n+2} = 0, \quad n \in \mathbb{Z},$$

thus

$$(1) \quad a_{n+2} = -n a_n, \quad n \in \mathbb{Z}.$$

Equations of this type are solved by first identifying those values of $n \in \mathbb{Z}$, for which one of the coefficients degenerate to 0 and then split the summation domain into different parts by means of these exception values. We see that an obvious zero is $n = 0$, where

$$a_2 = -0 \cdot a_0 = 0.$$

This proved that $a_2 = 0$, while a_0 can be chosen arbitrarily.

Then by induction of (1),

$$a_{2n} = 0, \quad \text{for } n \in \mathbb{N}.$$

This means that the possible Laurent series solution is now reduced to

$$(2) \quad f(z) = \sum_{n=0}^{+\infty} a_{-n} z^{-n} + \sum_{n=0}^{+\infty} a_{2n+1} z^{2n+1}.$$

Let us take a closer look on the latter series of (2),

$$\sum_{n=0}^{+\infty} a_{2n+1} z^{2n+1} = z \sum_{n=0}^{+\infty} a_{2n+1} (z^2)^n.$$

If $z \neq 0$, then it is convergent, if and only if

$$\sum_{n=0}^{+\infty} a_{2n+1} (z^2)^n$$

is convergent. Putting

$$b_n = a_{2n+1} \quad \text{and} \quad w = z^2,$$

we see that we shall examine the conditions of convergence of the auxiliary series

$$\sum_{n=0}^{+\infty} b_n w^n,$$

where we have by (1),

$$b_{n+1} = a_{2(n+1)+1} = a_{(2n+1)+2} = -(2n+1)a_{2n+1} = -(2n+1)b_n.$$



Maastricht University

*Leading
in Learning!*

**Join the best at
the Maastricht University
School of Business and
Economics!**

Top master's programmes

- 33rd place Financial Times worldwide ranking: MSc International Business
- 1st place: MSc International Business
- 1st place: MSc Financial Economics
- 2nd place: MSc Management of Learning
- 2nd place: MSc Economics
- 2nd place: MSc Econometrics and Operations Research
- 2nd place: MSc Global Supply Chain Management and Change

Sources: Keuzegids Master ranking 2013; Elsevier 'Beste Studies' ranking 2012; Financial Times Global Masters in Management ranking 2012

**Maastricht
University is
the best specialist
university in the
Netherlands
(Elsevier)**

**Visit us and find out why we are the best!
Master's Open Day: 22 February 2014**

www.mastersopenday.nl



This shows that if $b_0 \neq 0$, then all $b_n \neq 0$, $n \in \mathbb{N}_0$, and we can determine the w -radius of convergence,

$$\varrho_w = \lim_{n \rightarrow +\infty} \left| \frac{b_n}{b_{n+1}} \right| = \lim_{n \rightarrow +\infty} \left| \frac{b_n}{-(2n+1)b_n} \right| = \lim_{n \rightarrow +\infty} \frac{1}{2n+1} = 0,$$

so if $b_0 = a_1 \neq 0$, the series is only convergent for $w = 0$. Therefore, we are *forced* for reasons of convergence to put

$$a_1 = 0.$$

If $a_1 = 0$, then it follows from (1) that $a_3 = 0$, and thus

$$a_{2n+1} = 0, \quad n \in \mathbb{N},$$

by induction. The series is then reduced to

$$f(z) = \sum_{n=0}^{+\infty} a_{-n} z^{-n}.$$

If we replace n by $-n$ in (1), then

$$a_{-n+2} = n a_{-n}, \quad n \in \mathbb{Z},$$

so

$$(3) \quad a_{-n} = \frac{1}{n} a_{-n+2}, \quad n \in \mathbb{Z}.$$

If $n = 1$, then $a_{-1} = a_1 = 0$. If $n = 3$, then

$$a_{-3} = \frac{1}{3} a_{-1} = 0,$$

hence by induction,

$$a_{-2n+1} = 0, \quad n \in \mathbb{N}.$$

The series is now reduced to

$$f(z) = \sum_{n=0}^{+\infty} a_{-2n} z^{-2n}.$$

We now replace n by $2n$ in (3). Then we obtain the following recursion formula for a_{-2n} :

$$(4) \quad a_{-2n} = \frac{1}{2n} a_{-2n+2} = \frac{1}{2n} a_{-2(n-1)}, \quad n \in \mathbb{N}.$$

Finally, we put $c_n = a_{-2n}$. Then we derive from (4) the following recursion formula,

$$c_n = \frac{1}{2n} c_{n-1}, \quad n \in \mathbb{N}.$$

This is multiplied by $2^n n!$ in order to get

$$2^n n! c_n = 2^{n-1} (n-1)! c_{n-1}, \quad n \in \mathbb{N},$$

where we see that the right hand side is obtained from the left hand side by replacing n everywhere by $n - 1$. Therefore, by recursion,

$$2^n n! c_n = 2^{n-1} (n-1)! c_{n-1} = \cdots = 2^0 0! c_0 = c_0 = a_0,$$

hence

$$a_{-2n} = c_n = \frac{a_0}{2^n n!}, \quad n \in \mathbb{N}.$$

The corresponding formal Laurent series is then given by

$$f(z) = \sum_{n=0}^{+\infty} a_{-2n} z^{-2n} = a_0 \sum_{n=0}^{+\infty} \frac{1}{n!} \cdot \frac{1}{2^n} \left(\frac{1}{z^2}\right)^n = a_0 \sum_{n=0}^{+\infty} \frac{1}{n!} \left(\frac{1}{2z^2}\right)^n.$$

We should immediately *recognize* the exponential series which is convergent, if only

$$\left| \frac{1}{2z^2} \right| < +\infty, \quad \text{hence if } z \in \mathbb{C} \setminus \{0\}.$$

We have with only inspection found the domain of convergence, so the complete solution is given by

$$f(z) = a_0 \exp\left(\frac{1}{2z^2}\right), \quad \text{for } z \in \mathbb{C} \setminus \{0\}.$$

ALTERNATIVELY the differential equation *can* be solved by *inspection*. However, this solution is not obvious, so we have postponed it to this place of the example. First assume that we for some reason suspect that

$$a_n = 0 \quad \text{for } n \in \mathbb{N}.$$

The previous computations show that this is actually the case. This means that

$$f(z) = \sum_{n=0}^{+\infty} a_{-n} z^{-n} = \sum_{n=0}^{+\infty} a_{-n} w^n, \quad w = \frac{1}{z}.$$

If we put

$$g(w) = f(z) = f\left(\frac{1}{w}\right),$$

then $g(w)$ ought to be expanded as a *Taylor series* from $w_0 = 0$. We shall only find a differential equation for $g(w)$.

Since $w = \frac{1}{z}$ is a (one-to-one) transformation of $\mathbb{C} \setminus \{0\}$ onto itself, it follows by implicit differentiation that

$$\begin{aligned} 0 &= z^3 f'(z) + f(z) = z^3 \frac{d}{dz} f(z) + f(z) = z^3 \frac{dw}{dz} \frac{d}{dw} g(w) + g(w) \\ &= z^3 \cdot \left(-\frac{1}{z^2}\right) g'(w) + g(w) = -z g'(w) + g(w) = -\frac{1}{w} g'(w) + g(w), \end{aligned}$$

which we write for $w \in \mathbb{C} \setminus \{0\}$ in the following way

$$(5) \quad g'(w) - w g(w) = 0, \quad w \in \mathbb{C} \setminus \{0\}.$$

This equation is either solved by inserting a w -Taylor series

$$g(w) = \sum_{n=0}^{+\infty} b_n w^n,$$

and then apply the usual power series method, or by multiplying (5) by an integrating factor, which here can be chosen as $\exp\left(-\frac{1}{2}w^2\right) \neq 0$, and finally reduce.

The former standard method is left to the reader. In the latter case, however, we have the following equivalent equations,

$$\begin{aligned} 0 &= \exp\left(-\frac{1}{2}w^2\right) \frac{dg}{dw} - w \exp\left(-\frac{1}{2}w^2\right) \cdot g(w) \\ &= \exp\left(-\frac{1}{2}w^2\right) \frac{dg}{dw} + \frac{d}{dw} \left(\exp\left(-\frac{1}{2}w^2\right) \right) \cdot g(w) \\ &= \frac{d}{dw} \left\{ \exp\left(-\frac{1}{2}w^2\right) g(w) \right\}. \end{aligned}$$

An integration gives with an arbitrary constant $c \in \mathbb{C}$,

$$\exp\left(-\frac{1}{2}w^2\right) g(w) = c, \quad w \in \mathbb{C} \setminus \{0\}.$$

Finally, it follows from $g(w) = f(z)$ and $w = \frac{1}{z}$ that

$$f(z) = g(w) = c \cdot \exp\left(\frac{1}{2}w^2\right) = c \cdot \exp\left(\frac{1}{2z^2}\right), \quad z \in \mathbb{C} \setminus \{0\}.$$

Example 4.2 Find all Laurent series from 0, which are solutions of the differential equation

$$(z^2 - z) f'(z) = (1 - 2z) f(z),$$

and determine the domain of convergence.

First method. Inspection. By some rearrangements,

$$\begin{aligned} 0 &= (z^2 - z) f'(z) + (2z - 1) f(z) = (z^2 - z) f'(z) + \frac{d}{dz} (z^2 - z) \cdot f(z) \\ &= \frac{d}{dz} \left\{ (z^2 - z) f(z) \right\}. \end{aligned}$$

hence by integration,

$$(z^2 - z) f(z) = C,$$

and thus

$$f(z) = \frac{C}{z^2 - z} = \frac{C}{z(z - 1)} = -\frac{C}{z} + \frac{C}{z - 1}, \quad C \in \mathbb{C}, \quad z \neq 0, 1.$$

The Laurent series are then easily found in the two domains

$$0 < |z| < 1 \quad \text{and} \quad |z| > 1.$$

We shall find these in the **second method**, so we shall not give it here but refer to the following.

Second method. *Laurent series methode.* Assume that $f(z) = \sum a_n z^n$ is a formal Laurent series solution. Then

$$f'(z) = \sum n a_n z^{n-1},$$

and hence by insertion,

$$\begin{aligned} 0 &= (z^2 - z) f'(z) - (1 - 2z) f(z) \\ &= \sum n a_n z^{n+1} - \sum n a_n z^n - \sum a_n z^n + \sum 2a_n z^{n+1} \\ &= \sum (n+2) a_n z^{n+1} - \sum (n+1) a_n z^n \\ &= \sum (n+1) a_{n-1} z^n - \sum (n+1) a_n z^n \\ &= \sum (n+1) \{a_{n-1} - a_n\} z^n. \end{aligned}$$

Then we conclude from the *identity theorem* that we get the *recursion formula*

$$(n+1) \{a_{n-1} - a_n\} = 0, \quad n \in \mathbb{Z}.$$



> **Apply now**

REDEFINE YOUR FUTURE
**AXA GLOBAL GRADUATE
PROGRAM 2015**

redefining / standards 

agence edg. © Photonstop

Here, either $n = -1$, i.e.

$$0 \cdot \{a_{-1} - a_1\} = 0,$$

in which case a_{-2} does not have to be equal to a_{-1} , or $a_n = a_{n-1}$. Therefore, we conclude that

$$a_n = a_{-2} \quad \text{for } n \leq -2,$$

and

$$a_n = a_{-1} \quad \text{for } n \geq -1.$$

The formal solution is

$$f(z) = a_{-1} \sum_{n=-1}^{+\infty} z^n + a_{-2} \sum_{n=2}^{+\infty} \frac{1}{z^n}.$$

The former series converges for $|z| < 1$, and the latter for $|z| > 1$. This means that the series is divergent for all $z \in \mathbb{C}$, if $a_{-1} \cdot a_{-2} \neq 0$.

Then put $a_{-2} = 0$. We get

$$f(z) = a_{-1} \sum_{n=-1}^{+\infty} z^n = \frac{a_{-1}}{z} \cdot \frac{1}{1-z}, \quad 0 < |z| < 1.$$

If $a_{-1} = 0$, then

$$f(z) = a_{-2} \sum_{n=2}^{+\infty} \frac{1}{z^n} = \frac{a_{-2}}{z^2} \cdot \frac{1}{1 - \frac{1}{z}} = \frac{a_{-2}}{z} \cdot \frac{1}{z-1}, \quad |z| > 1.$$

Example 4.3 Find all Laurent series from 0, which are solution of the differential equation

$$z^3 f''(z) + (3z^2 + z) f'(z) + f(z) = 0,$$

and the domain of convergence.

Express the Laurent series by elementary functions.

First method. *Inspection.* It is possible in some cases to solve a differential equation by inspection.

Here we have an example of such an equation. This is, however, not always possible.

We rearrange the equation in the following way,

$$\begin{aligned} 0 &= z^3 f''(z) + (3z + z) f'(z) + f(z) = \{z^3 f''(z) + 3z^2 f'(z)\} + \{z f'(z) + f(z)\} \\ &= \frac{d}{dz} \{z^3 f'(z)\} + \frac{d}{dz} \{z f(z)\} = \frac{d}{dz} \{z^3 f'(z) + z f(z)\}. \end{aligned}$$

Therefore, if $z \neq 0$ we get by integration, including an arbitrary constant

$$z^3 f'(z) + z f(z) = z^3 \left\{ f'(z) + \frac{1}{z^2} f(z) \right\} = a,$$

thus

$$f'(z) + \frac{1}{z^2} f(z) = \frac{a}{z^3}, \quad z \neq 0.$$

We multiply this equation by $\exp\left(-\frac{1}{z}\right) \neq 0$, $z \neq 0$, in order to get

$$\begin{aligned} \frac{a}{z^3} \exp\left(-\frac{1}{z}\right) &= \exp\left(-\frac{1}{z}\right) f'(z) + \frac{d}{dz} \left(-\frac{1}{z}\right) \exp\left(-\frac{1}{z}\right) f(z) \\ &= \exp\left(-\frac{1}{z}\right) \frac{d}{dz} f(z) + \frac{d}{dz} \exp\left(-\frac{1}{z}\right) \cdot f(z) = \frac{d}{dz} \left\{ \exp\left(-\frac{1}{z}\right) f(z) \right\}. \end{aligned}$$

On the other hand, when $z \neq 0$ we get by the change of variable $u = -\frac{1}{z}$ that $\frac{du}{dz} = \frac{1}{z^2}$, and

$$\begin{aligned} \frac{1}{z^3} \exp\left(-\frac{1}{z}\right) &= -\frac{1}{z^2} \cdot \left(-\frac{1}{z}\right) \exp\left(-\frac{1}{z}\right) = -\frac{du}{dz} \cdot u e^u = -\frac{du}{dz} \frac{d}{du} \{(u-1)e^u\} \\ &= \frac{d}{dz} \{(1-u)e^u\} = \frac{d}{dz} \left\{ \left(1 + \frac{1}{z}\right) \exp\left(-\frac{1}{z}\right) \right\}. \end{aligned}$$

Hence by insertion

$$\frac{d}{dz} \left\{ \exp\left(\frac{1}{z}\right) f(z) \right\} = \frac{d}{dz} \left\{ a \left(1 + \frac{1}{z}\right) \exp\left(-\frac{1}{z}\right) \right\},$$

and by another integration including another arbitrary constant $b \in \mathbb{C}$,

$$\exp\left(-\frac{1}{z}\right) f(z) = a \left(1 + \frac{1}{z}\right) \exp\left(-\frac{1}{z}\right) + b.$$

The complete solution is

$$f(z) = a \left(1 + \frac{1}{z}\right) + b \exp\left(\frac{1}{z}\right), \quad a, b \in \mathbb{C}, \quad z \neq 0.$$

Second method. *Change of variable.* Since $a_0(z) = z^3$ is only 0 for $z = 0$, we see that $z = 0$ is the only singular point, so we may expect that any possible solution must have the domain of definition $\mathbb{C} \setminus \{0\}$. Since $\mathbb{C} \setminus \{0\}$ is mapped into itself by the transformation $w = \frac{1}{z}$, an idea would be to see what this equation is mapped into by this transformation.

Let $z \neq 0$ and $w = \frac{1}{z}$, and let g be given by

$$g(w) = g\left(\frac{1}{z}\right) = f(z).$$

We shall set up a differential equation for $g(w)$. It follows by the *chain rule* that

$$f'(z) = g' \left(\frac{1}{z} \right) \cdot \left(-\frac{1}{z^2} \right) = -w^2 g'(w),$$

and

$$f''(z) = \frac{1}{z^4} g'' \left(\frac{1}{z} \right) + \frac{2}{z^3} g' \left(\frac{1}{z} \right) = w^4 g''(w) + 2w^3 g'(w),$$

which put into the differential equation give

$$\begin{aligned} 0 &= z^3 f''(z) + (3z^2 + z) f'(z) + f(z) \\ &= \frac{1}{w^3} \{w^4 g''(w) + 2w^3 g'(w)\} + \left\{ \frac{3}{w^2} + \frac{1}{w} \right\} \cdot \{-w^2 g'(w)\} + g(w) \\ &= w g''(w) + 2 g'(w) - 3 g'(w) - w g'(w) + g(w) \\ &= \{w g''(w) - g'(w)\} - \{w g'(w) - g(w)\}. \end{aligned}$$

The latter two expressions are the numerator of the derivative of a fraction of denominator w . Thus, if the equation is divided by $w^2 \neq 0$, then

$$0 = \frac{w g''(w) - 1 \cdot g'(w)}{w^2} - \frac{w g'(w) - 1 \cdot g(w)}{w^2} = \frac{d}{dw} \left\{ \frac{g'(w)}{w} - \frac{g(w)}{w} \right\},$$

hence by integration,

$$\frac{g'(w) - g(w)}{w} = -a, \quad a \in \mathbb{C}.$$

We have here chosen the sign in front of the arbitrary constant $a \in \mathbb{C}$ in order to ease some later computations.

The numerator looks like the derivative of $ew^{-w}g(w)$, where we are only missing the factor e^{-w} . Therefore, we multiply the equation by $w e^{-w}$ in order to get

$$\frac{d}{dw} \{e^{-w}g(w)\} = e^{-w}g'(w) - e^{-w}g(w) = -a w e^{-w} = \frac{d}{dw} \{a(w+1)e^{-w}\},$$

where the latter equality is proved by a simple test.

An integration with respect to w then gives with a new arbitrary constant $b \in \mathbb{C}$ that

$$e^{-w}g(w) = a(w+1)e^{-w} + b,$$

so we obtain the complete solution

$$f(z) = g(w) = a(1+w) + b e^w = a \left(1 + \frac{1}{z} \right) + b \exp \left(\frac{1}{z} \right), \quad z \neq 0.$$

Third method. *The standard method.* We put a formal Laurent series

$$f(z) = \sum_{n=-\infty}^{+\infty} a_n z^n = \sum a_n z^n, \quad r < |z| < R,$$

into the original differential equation. Then we have in the domain of convergence $r < |z| < R$ (note that in particular $z \neq 0$) that

$$f(z) = \sum a_n z^n, \quad f'(z) = \sum n a_n z^{n-1}, \quad f''(z) = \sum n(n-1) a_n z^{n-2},$$

hence by insertion into the equation

$$\begin{aligned} 0 &= z^3 f''(z) + (3z^2 + z) f'(z) + f(z) \\ &= z^3 \sum n(n-1) a_n z^{n-2} + 3z^2 \sum n a_n z^{n-1} + z \sum n a_n z^{n-1} + \sum a_n z^n \\ &= \sum n(n-1) a_n z^{n+1} + \sum 3n a_n z^{n+1} + \sum n a_n z^n + \sum a_n z^n \\ &= \sum \{n^2 - n + 3n\} a_n z^{n+1} + \sum (n+1) a_n z^n \\ &= \sum n(n+2) a_n z^{n+1} + \sum (n+1) a_n z^n \\ &= \sum (n-1)(n+1) a_{n-1} z^n + \sum (n+1) a_n z^n \\ &= \sum (n+1) \{(n-1) a_{n-1} + a_n\} z^n. \end{aligned}$$



BI

Business
Strategic Marketing Management
International Business
Leadership & Organisational Psychology
Shipping Management
Financial Economics

BI NORWEGIAN BUSINESS SCHOOL

EFMD
EQUIS
ACCREDITED

**Empowering People.
Improving Business.**

BI Norwegian Business School is one of Europe's largest business schools welcoming more than 20,000 students. Our programmes provide a stimulating and multi-cultural learning environment with an international outlook ultimately providing students with professional skills to meet the increasing needs of businesses.

BI offers four different two-year, full-time Master of Science (MSc) programmes that are taught entirely in English and have been designed to provide professional skills to meet the increasing need of businesses. The MSc programmes provide a stimulating and multi-cultural learning environment to give you the best platform to launch into your career.

- MSc in Business
- MSc in Financial Economics
- MSc in Strategic Marketing Management
- MSc in Leadership and Organisational Psychology

www.bi.edu/master

This equation is fulfilled in the domain of convergence, so we obtain the following *recursion formula*

$$(6) \quad (n+1)\{(n-1)a_{n-1} + a_n\} = 0, \quad n \in \mathbb{Z},$$

where we must not cancel the common factor $(n+1)$.

If $n = -1$, then $n+1 = 0$, and (6) is fulfilled, no matter the choices of the values of $a_{-1-1} = a_{-2}$ and a_{-1} . Hence we conclude that a_{-2} and a_{-1} are independent of each other, and we may for the time being consider them as being arbitrary.

When $n \neq -1$, formula (6) is reduced to

$$(7) \quad (n-1)a_{n-1} + a_n = 0, \quad n \in \mathbb{Z} \setminus \{-1\}.$$

When $n = 1$, we get $a_1 = 0$, hence by recursion for $n \in \mathbb{N}$,

$$a_n = -(n-1)a_{n-1} = \cdots = (-1)^{n-1}(n-1)!a_1 = 0,$$

thus

$$a_n = 0 \quad \text{for } n \in \mathbb{N} \text{ positive.}$$

If $n = 0$, then $-a_{-1} + a_0 = 0$, so $a_0 = a_{-1}$, and

$$a_0 + \frac{a_{-1}}{z} = a_{-1} \left(1 + \frac{1}{z}\right)$$

determines one family of solutions for $a_{-1} \in \mathbb{C}$.

We have proved that a solution necessarily must have the form

$$f(z) = a_{-1} \left(1 + \frac{1}{z}\right) + \sum_{n=-2}^{-\infty} a_n z^n = a_{-1} \left(1 + \frac{1}{z}\right) + \sum_{n=2}^{+\infty} b_n \frac{1}{z^n}, \quad z \neq 0,$$

where we have put $b_n = a_{-n}$, $n \in \mathbb{N} \setminus \{1\}$. We shall derive a *recursion formula* for b_n , $n \in \mathbb{N} \setminus \{1\}$. If we write $-n$ instead of n in (7), then

$$(-n-1)a_{-n-1} + a_{-n} = 0, \quad n \in \mathbb{N} \setminus \{1\},$$

which expressed by the b_n becomes

$$(n+1)b_{n+1} = b_n, \quad n \in \mathbb{N} \setminus \{1\}.$$

We multiply this equation by $n!$ in order to get

$$(n+1)!b_{n+1} = n!b_n = \cdots = 2!b_2 = 2b_2, \quad n \in \mathbb{N} \setminus \{1\},$$

thus

$$a_{-n} = b_n = \frac{2}{n!}b_2 = \frac{2}{n!}a_{-2},$$

and we have (formally) for $z \neq 0$,

$$\begin{aligned} f(z) &= a_{-1} \left(1 + \frac{1}{z}\right) + \sum_{n=2}^{+\infty} \frac{2}{n!} a_{-2} \frac{1}{z^n} = a_{-1} \left(1 + \frac{1}{z}\right) + 2a_{-2} \sum_{n=2}^{+\infty} \frac{1}{n!} \left(\frac{1}{z}\right)^n \\ &= a_{-1} \left(1 + \frac{1}{z}\right) + 2a_{-2} \sum_{n=0}^{+\infty} \frac{1}{n!} \left(\frac{1}{z}\right)^n - 2a_{-2} \left(1 + \frac{1}{z}\right) \\ &= (a_{-1} - 2a_{-2}) \left(1 + \frac{1}{z}\right) + 2a_{-2} \exp\left(\frac{1}{z}\right), \end{aligned}$$

which is true for all $z \neq 0$, because the exponential series

$$\sum_{n=0}^{+\infty} \frac{1}{n!} \left(\frac{1}{z}\right)^n = \exp\left(\frac{1}{z}\right)$$

is convergent for $\left|\frac{1}{z}\right| < +\infty$, i.e. for $z \neq 0$. Only the zero solution can be extended to \mathbb{C} .

Example 4.4 Find all Laurent series from 0, which are solutions of the differential equation

$$z^3 f''(z) + z^2 f'(z) - f(z) = 0,$$

and determine the domain of convergence.

Assume that

$$f(z) = \sum a_n z^n, \quad r < |z| < R,$$

is a Laurent series solution. Then

$$f'(z) = \sum n a_n z^{n-1} \quad \text{and} \quad f''(z) = \sum n(n-1) a_n z^{n-2}$$

in the same domain. Then by insertion into the differential equation,

$$\begin{aligned} 0 &= z^3 f''(z) + z^2 f'(z) - f(z) = \sum n(n-1) a_n z^{n+1} + \sum n a_n z^{n+1} - \sum a_n z^n \\ &= \sum n^2 a_n z^{n+1} - \sum a_{n+1} z^{n+1} = \sum \{n^2 a_n - a_{n+1}\} z^{n+1}. \end{aligned}$$

From the identity theorem we get the *recursion formula*

$$(8) \quad a_{n+1} = n^2 a_n, \quad n \in \mathbb{Z}.$$

If $n = 0$, then $a_1 = 0$. We continue by recursion to get $a_n = 0$ for all $n \in \mathbb{N}$, and we see that only terms of non-positive indices are important.

We put $b_n = a_{-n}$, $n \in \mathbb{N}_0$, and write $-n$, $n \in \mathbb{N}_0$, instead of n in (8). Then we get the *recursion formula*

$$(9) \quad n^2 b_n = (-n)^2 a_{-n} = a_{-n+1} = b_{n-1}, \quad n \in \mathbb{N}.$$

We multiply this equation by $\{(n-1)!\}^2$ to get

$$\{n!\}^2 b_n = \{(n-1)!\}^2 b_{n-1} = \dots = \{0!\}^2 b_0 = b_0, \quad n \in \mathbb{N}_0,$$

thus

$$a_{-n} = b_n = \frac{1}{\{n!\}^2} a_0, \quad n \in \mathbb{N}_0.$$

The series is then

$$f(z) = a_0 \sum_{n=0}^{+\infty} \frac{1}{(n!)^2} \cdot \frac{1}{z^n}, \quad z \in \mathbb{C} \setminus \{0\}, \quad a_0 \in \mathbb{C},$$

where it is easy to prove that

$$\sum_{n=0}^{+\infty} \frac{1}{(n!)^2} w^n$$

has radius of convergence $+\infty$.

Remark 4.2 We note that we in this case only get one Laurent series in spite of the fact that the equation is of second order. \diamond

Remark 4.3 One can prove that the series solution can be expressed by a *Bessel function*. \diamond

Example 4.5 Find all Laurent series from 0, which are solutions of the differential equation

$$z^4 f''(z) + 2z^3 f'(z) + f(z) = 0.$$

Determine the domain of convergence for each of them. Finally, express the Laurent series by elementary functions.

Assume that the solution is given on the form

$$f(z) = \sum_{n=-\infty}^{+\infty} a_n z^n = \sum a_n z^n, \quad r < |z| < R.$$

Then we have in the domain of convergence,

$$f'(z) = \sum n a_n z^{n-1}, \quad f''(z) = \sum n(n-1) a_n z^{n-2},$$

hence by insertion into the differential equation,

$$\begin{aligned} 0 &= z^4 f''(z) + 2z^3 f'(z) + f(z) = \sum n(n-1) a_n z^{n+2} + \sum 2n a_n z^{n+2} + \sum a_n z^n \\ &= \sum n(n+1) a_n z^{n+2} + \sum a_{n+2} z^{n+2} = \sum \{n(n+1) a_n + a_{n+2}\} z^{n+2}. \end{aligned}$$

We derive from this the *recursion formula*

$$(10) \quad a_{n+2} = -n(n+1)a_n, \quad n \in \mathbb{Z}.$$

If $n = 0$, then we see that a_0 is an indeterminate and $a_2 = 0$. Then by recursion,

$$a_{2n} = 0 \quad \text{for all } n \in \mathbb{N}.$$

If $n = -1$, then a_{-1} is an indeterminate and $a_1 = 0$. By recursion we get

$$a_{2n+1} = 0 \quad \text{for all } n \in \mathbb{N}_0.$$

Summing up we have

$$a_n = 0 \quad \text{for all } n \in \mathbb{N}.$$

When we replace n by $-n$, and write b_n instead of a_{-n} , then

$$-(-n)(-n+1)a_{-n} = -n(n-1)b_n = a_{-n+2} = b_{n-2}, \quad n \in \mathbb{N} \setminus \{1\},$$

Need help with your dissertation?

Get in-depth feedback & advice from experts in your topic area. Find out what you can do to improve the quality of your dissertation!

Get Help Now



Go to www.helpmyassignment.co.uk for more info



Click on the ad to read more

hence

$$(11) \quad -n(n-1)b_n = b_{n-2}, \quad n \in \mathbb{N} \setminus \{1\}.$$

Thus we get by multiplying by $-(n-2)!$,

$$+n!b_n = -(n-2)!b_{n-2}, \quad n \in \mathbb{N} \setminus \{1\},$$

and then we have to split the investigation according to whether n is even or odd.

(a) If $n = 2p$ is even, then

$$(2p)!b_{2p} = -(2p-2)!b_{2p-2} = \cdots = (-1)^p 0!b_0 = (-1)^p a_0,$$

hence

$$a_{-2n} = b_{2n} = \frac{(-1)^n}{(2n)!} a_0, \quad n \in \mathbb{N}_0.$$

(b) If $n = 2p + 1$, $p \in \mathbb{N}_0$, is odd, then

$$(2p+1)!b_{2p+1} = -(2p-1)!b_{2p-1}b_{2p-1} = \cdots = (-1)^p \cdot 1!b_1 = (-1)^p a_{-1},$$

hence

$$a_{-2n-1} = b_{2n+1} = \frac{(-1)^n}{(2n+1)!} a_{-1}, \quad n \in \mathbb{N}_0.$$

In both cases the corresponding series are convergent for $\left|\frac{1}{z}\right| < +\infty$, i.e. for $z \neq 0$, and with exception of the zero solution (which is convergent in \mathbb{C}) the domain of convergence is $\mathbb{C} \setminus \{0\}$.

Finally, we recognize the coefficients as belonging to the cosine and the sine series respectively, so

$$\begin{aligned} f(z) &= \sum_{n=0}^{+\infty} a_{-n} \cdot \frac{1}{z^n} = a_0 \sum_{n=0}^{+\infty} \frac{(-1)^n}{(2n)!} \left(\frac{1}{z}\right)^{2n} + a_{-1} \sum_{n=0}^{+\infty} \frac{(-1)^n}{(2n+1)!} \left(\frac{1}{z}\right)^{2n+1} \\ &= a_0 \cos\left(\frac{1}{z}\right) + a_{-1} \sin\left(\frac{1}{z}\right). \quad z \in \mathbb{C} \setminus \{0\}. \end{aligned}$$

Example 4.6 Find all Laurent series from 0, which are solutions of the differential equation

$$z^4 f''(z) + 2z^3 f'(z) - f(z) = 0.$$

Determine the domain of convergence for each of these. Finally, express the Laurent series by elementary functions.

When we for $r < |z| < R$ put

$$f(z) = \sum a_n z^n, \quad f'(z) = \sum n a_n z^{n-1}, \quad f''(z) = \sum n(n-1) a_n z^{n-2},$$

into the differential equation, then

$$\begin{aligned} 0 &= z^4 f''(z) + 2z^3 f'(z) - f(z) = \sum n(n-1)a_n z^{n+2} + \sum 2n a_n z^{n+2} - \sum a_n z^n \\ &= \sum n(n+1)a_n z^{n+2} - \sum a_{n+2} z^{n+2} = \sum \{n(n+1)a_n - a_{n+2}\} z^{n+2}. \end{aligned}$$

It follows by the identity theorem that we have the *recursion formula*

$$(12) \quad a_{n+2} = n(n+1)a_n, \quad n \in \mathbb{Z}.$$

If $n = 0$, then $a_2 = 0$, and hence by induction,

$$a_{2n} = 0 \quad \text{for } n \in \mathbb{N},$$

while a_0 is an indeterminate.

If $n = -1$, then $a_1 = 0$, and hence by induction,

$$a_{2n+1} = 0 \quad \text{for } n \in \mathbb{N}_0,$$

while a_{-1} is an indeterminate.

Summing up we have

$$a_n = 0 \quad \text{for } n \in \mathbb{N}.$$

If we put $b_n = a_{-n}$, $n \in \mathbb{N}_0$ and replace n by $-n$ in (12), then we get

$$(13) \quad b_{n-2} = a_{-n+2} = (-n)(-n+1)a_{-n} = n(n-1)b_n, \quad n \in \mathbb{N} \setminus \{1\}.$$

If we multiply (13) by $(n-2)!$, we get

$$n! b_n = (n-2)! b_{n-2}.$$

Here there is a leap of 2 in the indices, so we must split into the cases of even or odd indices. We find

$$(2n)! b_{2n} = (2\{n-1\})! b_{2(n-1)} = \cdots = 0! b_0 = a_0,$$

$$(2n+1)! b_{2n+1} = (2\{n-1\}+1)! b_{2(n-1)+1} = \cdots = 1! b_1 = a_{-1},$$

hence

$$a_{-2n} = b_{2n} = \frac{1}{(2n)!} a_0 \quad \text{and} \quad a_{-2n-1} = b_{2n+1} = \frac{1}{(2n+1)!} a_{-1}, \quad n \in \mathbb{N}_0.$$

Thus the formal Laurent series solution is given by

$$f(z) = a_0 \sum_{n=0}^{+\infty} \frac{1}{(2n)!} \cdot \frac{1}{z^{2n}} + a_{-1} \sum_{n=0}^{+\infty} \frac{1}{(2n+1)!} \cdot \frac{1}{z^{2n+1}} = a_0 \cosh\left(\frac{1}{z}\right) + a_{-1} \sinh\left(\frac{1}{z}\right).$$

The determination of the domain of convergence $\mathbb{C} \setminus \{0\}$ is trivial, because we only consider known series which are convergent for $\left|\frac{1}{z}\right| < +\infty$.

Only the zero solution can be extended to all of \mathbb{C} .

ALTERNATIVELY, the coefficient $a_0(z) = z^4$ leads one to the idea of transforming the differential equation into a differential equation in the new variable $w = \frac{1}{z}$, $z \neq 0$, $w \neq 0$. If we put

$$f(z) = g\left(\frac{1}{z}\right) = g(w).$$

then

$$\frac{dw}{dz} = -\frac{1}{z^2} = -w^2,$$

and

$$f'(z) = -w^2 g'(w) \quad \text{and} \quad f''(z) = w^4 g''(w) + 2w^3 g'(w).$$

Since $zw = 1$, it follows by insertion that

$$g''(w) - g(w) = 0,$$

the complete solution of which is

$$g(w) = c_1 e^w + c_2 e^{-w} = a_0 \cosh w + a_{-1} \sinh w.$$

Then finally.

$$f(z) = c_1 \exp\left(\frac{1}{z}\right) + c_2 \exp\left(-\frac{1}{z}\right) = a_0 \cosh\left(\frac{1}{z}\right) + a_{-1} \sinh\left(\frac{1}{z}\right), \quad z \in \mathbb{C} \setminus \{0\}.$$

Example 4.7 Find all Laurent series from 0 which are solutions of the differential equation

$$z^4 f''(z) + 4z^3 f'(z) + (2z^2 + 1) f(z) = 0,$$

and determine the domain of convergence.

If we put the formal Laurent series

$$f(z) = \sum_{n=-\infty}^{+\infty} a_n z^n = \sum a_n z^n, \quad r < |z| < R,$$

and its formal derivatives

$$f'(z) = \sum n a_n z^{n-1} \quad \text{og} \quad f''(z) = \sum n(n-1) a_n z^{n-2},$$

into the differential equation, then

$$\begin{aligned} 0 &= z^4 f''(z) + 4z^3 f'(z) + (2z^2 + 1) f(z) \\ &= \sum n(n-1) a_n z^{n+2} + \sum 4n a_n z^{n+2} + \sum 2a_n z^{n+2} + \sum a_n z^n \\ &= \sum (n^2 + 3n + 2) a_n z^{n+2} + \sum a_n z^n \\ &= \sum (n+1)(n+2) a_n z^{n+2} + \sum a_n z^n \\ &= \sum (n-1)n a_{n-2} z^n + \sum a_n z^n \\ &= \sum \{(n-1)n a_{n-2} + a_n\} z^n. \end{aligned}$$

Then apply the *identity theorem* on this in order to get the *recursion formula*

$$(14) \quad (n-1)n a_{n-2} + a_n = 0, \quad n \in \mathbb{Z}.$$

If $n = 0$, then $a_0 = 0$, and a_{-2} is an indeterminate.

If $n = 1$, then $a_1 = 0$, and a_{-1} is an indeterminate.

It follows from $a_0 = a_1 = 0$ and

$$a_n = -(n-1)n a_{n-2} \quad \text{for } n \geq 2,$$

by recursion that

$$a_n = 0 \quad \text{for } n \in \mathbb{N}_0.$$

Put $b_n = a_{-n}$. Then it follows from (14) for $n \in \mathbb{N}$ that

$$(-n-1)(-n)a_{-n-2} + a_{-n} = n(n+1)b_{n+2} + b_n = 0, \quad \text{for } n \in \mathbb{N},$$

thus

$$(15) \quad b_{n+2} = -\frac{1}{(n+1)n} b_n, \quad n \in \mathbb{N}.$$



Brain power

By 2020, wind could provide one-tenth of our planet's electricity needs. Already today, SKF's innovative know-how is crucial to running a large proportion of the world's wind turbines.

Up to 25 % of the generating costs relate to maintenance. These can be reduced dramatically thanks to our systems for on-line condition monitoring and automatic lubrication. We help make it more economical to create cleaner, cheaper energy out of thin air.

By sharing our experience, expertise, and creativity, industries can boost performance beyond expectations.

Therefore we need the best employees who can meet this challenge!

The Power of Knowledge Engineering

Plug into The Power of Knowledge Engineering.
Visit us at www.skf.com/knowledge

SKF



The leap of the indices in (15) is 2, so we must split the following into the cases of even or odd indices.

(a) If $n = 2p$, $p \in \mathbb{N}$, is even, then it follows by p recursions that

$$b_{2p+2} = b_{2(p+1)} = -\frac{1}{(2p+1) \cdot 2p} b_{2p} = \dots = \frac{(-1)^p}{(2p+1)!} b_2.$$

(b) If $n = 2p - 1$, $p \in \mathbb{N}$, is odd, then it follows by p recursions that

$$b_{2p+1} = -\frac{1}{2p(2p-1)} b_{2p-1} = \dots = \frac{(-1)^p}{(2p)!} b_1.$$

Hence the complete solution is

$$\begin{aligned} f(z) &= b_2 \sum_{p=0}^{+\infty} \frac{(-1)^p}{(2p+1)!} \cdot \frac{1}{z^{2p+2}} + b_1 \sum_{p=0}^{+\infty} \frac{(-1)^p}{(2p)!} \cdot \frac{1}{z^{2p+1}} \\ &= a_{-2} \cdot \frac{1}{z} \sum_{p=0}^{+\infty} \frac{(-1)^p}{(2p+1)!} \left(\frac{1}{z}\right)^{2p+1} + a_{-1} \cdot \frac{1}{z} \sum_{p=0}^{+\infty} \frac{(-1)^p}{(2p)!} \left(\frac{1}{z}\right)^{2p} \\ &= a_{-2} \cdot \frac{1}{z} \sin\left(\frac{1}{z}\right) + a_{-1} \cdot \frac{1}{z} \cos\left(\frac{1}{z}\right), \end{aligned}$$

where we recognize the trigonometric series, which are convergent for $\left|\frac{1}{z}\right| < +\infty$, thus the domain of convergence is $\mathbb{C} \setminus \{0\}$.

Example 4.8 (a) Find all Laurent series solutions from $z_0 = 0$ of the differential equation

$$(16) \quad z \frac{d^2 f}{dz^2} + (z+3) \frac{df}{dz} + 2f(z) = 0, \quad z \in \mathbb{C},$$

and determine their domains of convergence.

(b) Use e.g. the exponential series to express the complete solution by means of known elementary functions.

HINT: There are some solution possibilities. In one of them one needs the simple formula

$$\frac{1}{(n+2)n!} = \frac{1}{(n+1)!} - \frac{1}{(n+2)!}.$$

(c) Explain why there exists precisely one solution $f(z)$ of (16) fulfilling $f(0) = 1$, and find it.

(a) If we put the formal Laurent series

$$f(z) = \sum a_n z^n, \quad f'(z) = \sum n a_n z^{n-1}, \quad f''(z) = \sum n(n-1) a_n z^{n-2},$$

into (16), then

$$\begin{aligned}
 0 &= z \sum n(n-1)a_n z^{n-2} + z \sum n a_n z^{n-1} + \sum 3n a_n z^{n-1} + \sum 2a_n z^n \\
 &= \sum n(n-1)a_n z^{n-1} + \sum n a_n z^n + \sum 3n a_n z^{n-1} + \sum 2a_n z^n \\
 &= \sum n(n+2)a_n z^{n-1} + \sum (n+2)a_n z^n \\
 &= \sum n(n+2)a_n z^{n-1} + \sum (n+1)a_{n-1} z^{n-1} \\
 &= \sum \{n(n+2)a_n + (n+1)a_{n-1}\} z^{n-1}.
 \end{aligned}$$

Then it follows from the *identity theorem* that we get the *recursion formula*

$$(17) \quad n(n+2)a_n + (n+1)a_{n-1} = 0 \quad \text{for } n \in \mathbb{Z}.$$

The coefficients of the recursion formula have the obvious “zeros” $n = -2, -1$ and 0 . These are checked separately.

- If $n = -2$, then

$$0 \cdot a_{-2} - a_{-3} = 0,$$

hence

$$a_{-3} = 0 \quad \text{and} \quad a_{-2} \text{ is arbitrary.}$$

- If $n = -1$, then

$$-a_{-1} + 0 \cdot a_{-2} = 0,$$

hence

$$a_{-1} = 0 \quad \text{and} \quad a_{-2} \text{ is arbitrary.}$$

- If $n = 0$, then

$$0 \cdot a_0 + a_{-1} = 0,$$

hence

$$a_{-1} = 0 \quad \text{and} \quad a_0 \text{ is arbitrary.}$$

- If $n < -2$, then it follows from (17) that

$$a_{n-1} = -\frac{n(n+2)}{n+1} a_n, \quad n \leq -3, \quad a_{-3} = 0,$$

and we conclude by induction,

$$a_n = 0 \quad \text{for } n \leq -3.$$

- If $n > 0$, then it follows from (17) that

$$n(n+2)a_n = -(n+1)a_{n-1}, \quad n \in \mathbb{N}.$$

When we multiply this formula by $(-1)^n \cdot (n-1)! \neq 0$, then we get the equivalent formulæ

$$(-1)^n n! (n+2)a_n = (-1)^{n-1} (n-1)! (\{n-1\} + 2)a_{n-1} = \cdots = (-1)^0 0! 2a_0 = 2a_0,$$

and we conclude that

$$a_n = \frac{2(-1)^n}{(n+2)n!} a_0 = 2(-1)^n \cdot \frac{n+1}{(n+2)!} a_0.$$

The formal Laurent series solutions are therefore given by

$$f(z) = \frac{a_{-2}}{z^2} + 2a_0 \sum_{n=0}^{+\infty} \frac{n+1}{(n+2)!} (-z)^n.$$

It follows from

$$\left| \sum_{n=0}^{+\infty} a_n z^n \right| \leq \sum_{n=0}^{+\infty} 2|a_0| \cdot \frac{|z|^n}{(n+2)n!} \leq 2|a_0| \sum_{n=0}^{+\infty} \frac{|z|^n}{n!} = 2|a_0| \exp(|z|),$$

by the *criterion of comparison* that the series is convergent for every $z \in \mathbb{C}$. Hence, if $a_{-2} \neq 0$, then the complete solution is

$$f(z) = \frac{a_{-2}}{z^2} + 2a_0 \sum_{n=0}^{+\infty} \frac{n+1}{(n+2)!} (-z)^n, \quad \text{for } z \in \mathbb{C} \setminus \{0\}.$$

This solution can only be extended to all of \mathbb{C} , if $a_{-2} = 0$.

- (b) If $z \neq 0$, then

$$\begin{aligned} \sum_{n=0}^{+\infty} \frac{n+1}{(n+2)!} (-z)^n &= \sum_{n=0}^{+\infty} \frac{n+2-1}{(n+2)!} (-z)^n = \sum_{n=0}^{+\infty} \frac{(-z)^n}{(n+1)!} - \sum_{n=0}^{+\infty} \frac{(-z)^n}{(n+2)!} \\ &= -\frac{1}{z} \sum_{n=0}^{+\infty} \frac{(-z)^{n+1}}{(n+1)!} - \frac{1}{z^2} \sum_{n=0}^{+\infty} \frac{(-z)^{n+2}}{(n+2)!} = -\frac{1}{z} \sum_{n=1}^{+\infty} \frac{1}{n!} (-z)^n - \frac{1}{z^2} \sum_{n=2}^{+\infty} \frac{(-z)^n}{n!} \\ &= -\frac{1}{z} \{e^{-z} - 1\} - \frac{1}{z^2} \{e^{-z} - 1 + z\} = -\frac{1}{z} e^{-z} + \frac{1}{z} - \frac{1}{z^2} e^{-z} + \frac{1}{z^2} - \frac{1}{z} \\ &= \frac{1}{z^2} \{1 - (1+z)e^{-z}\}. \end{aligned}$$

Hence we conclude that if $z \neq 0$, then the complete solution is given by

$$f(z) = \frac{a_{-2}}{z^2} + 2a_0 \cdot \frac{1 - (1+z)e^{-z}}{z^2}.$$

Since

$$\frac{1 - (1+z)e^{-z}}{z^2} = \sum_{n=0}^{+\infty} \frac{n+1}{(n+2)!} (-z)^n \quad \text{for } z \neq 0,$$

it follows by taking the limit that

$$\lim_{z \rightarrow 0} \frac{1 - (1+z)e^{-z}}{z^2} = \frac{0+1}{(0+2)!} = \frac{1}{2}.$$

(c) The solution

$$f(z) = \frac{a_{-2}}{z^2} + 2a_0 \cdot \frac{1 - (1+z)e^{-z}}{z^2}$$

is according to the above bounded for $z \rightarrow 0$, were the limit value exists, if and only if $a_{-2} = 0$. When this is the case, we have

$$\lim_{z \rightarrow 0} f(z) = 2a_0 \lim_{z \rightarrow 0} \frac{1 - (1+z)e^{-z}}{z^2} = 2 \cdot a_0 \cdot \frac{1}{2} = a_0 = 1.$$

Thus the solution is

$$f(z) = 2 \sum_{n=0}^{+\infty} \frac{n+1}{(n+2)!} (-z)^n = \begin{cases} 2 \cdot \frac{1 - (1+z)e^{-z}}{z^2} & \text{for } z \neq 0, \\ 1 & \text{for } z = 0. \end{cases}$$

Remark 4.4 It is actually possible to solve the equation (16) directly without using Laurent series. However, the trick and the reformulations are somewhat sophisticated. We give for completeness a short review of this solution and emphasize at the same time that this is not a trivial solution. \diamond



What do you want to do?

No matter what you want out of your future career, an employer with a broad range of operations in a load of countries will always be the ticket. Working within the Volvo Group means more than 100,000 friends and colleagues in more than 185 countries all over the world. We offer graduates great career opportunities – check out the Career section at our web site www.volvogroup.com. We look forward to getting to know you!

VOLVO
AB Volvo (publ)
www.volvogroup.com

VOLVO TRUCKS | RENAULT TRUCKS | MACK TRUCKS | VOLVO BUSES | VOLVO CONSTRUCTION EQUIPMENT | VOLVO PENTA | VOLVO AERO | VOLVO IT
VOLVO FINANCIAL SERVICES | VOLVO 3P | VOLVO POWERTRAIN | VOLVO PARTS | VOLVO TECHNOLOGY | VOLVO LOGISTICS | BUSINESS AREA ASIA



Since $z = 0$ is a singular point, we assume in general in the following that $z \neq 0$. The not so obvious idea is then to multiply the differential equation by $z \neq 0$. Then

$$z^2 \frac{d^2 f}{dz^2} + z^2 \frac{df}{dz} + 3z \frac{df}{dz} + 2z f(z) = 0.$$

Now,

$$z^2 \frac{d^2 f}{dz^2} + 2z \frac{df}{dz} = \frac{d}{dz} \left\{ z^2 \frac{df}{dz} \right\}$$

and analogously,

$$z^2 \frac{df}{dz} + 2z f(z) = \frac{d}{dz} \{ z^2 f(z) \}.$$

We shall therefore try to reduce the equation by applying these formulæ, where we immediately must admit that we always will get an extra term $z \frac{df}{dz}$, which apparently cannot be removed. When we try this program above, then

$$\begin{aligned} 0 &= z^2 \frac{d^2 f}{dz^2} + z^2 \frac{df}{dz} + 3z \frac{df}{dz} + 2z f(z) \\ &= \left\{ z^2 \frac{d^2 f}{dz^2} + 2z \frac{df}{dz} \right\} + z \frac{df}{dz} + \left\{ z^2 \frac{df}{dz} + 2z f(z) \right\} \\ &= \frac{d}{dz} \left\{ z^2 \frac{df}{dz} \right\} + z \frac{df}{dz} + \frac{d}{dz} \{ z^2 f(z) \}. \end{aligned}$$

Since

$$z^2 \frac{df}{dz} = \frac{d}{dz} \{ z^2 f(z) \} - 2z f(z),$$

it follows by insertion that

$$\begin{aligned} 0 &= \frac{d}{dz} \left(\frac{d}{dz} \{ z^2 f(z) \} - 2z f(z) \right) + z \frac{df}{dz} + \frac{d}{dz} \{ z^2 f(z) \} \\ &= \frac{d^2}{dz^2} \{ z^2 f(z) \} - 2f(z) - 2z \frac{df}{dz} + z \frac{df}{dz} + \frac{d}{dz} \{ z^2 f(z) \} \\ &= \frac{d}{dz} \left(\frac{d}{dz} \{ z^2 f(z) \} \right) + \frac{d}{dz} \{ z^2 f(z) \} - \left\{ z \frac{df}{dz} + 2f(z) \right\} \\ &= \frac{d}{dz} \left(\frac{d}{dz} \{ z^2 f(z) \} \right) + \frac{d}{dz} \{ z^2 f(z) \} - \frac{1}{z} \left\{ z^2 \frac{df}{dz} + 2z f(z) \right\} \\ &= \frac{d}{dz} \left(\frac{d}{dz} \{ z^2 f(z) \} \right) + \left(1 - \frac{1}{z} \right) \frac{d}{dz} \{ z^2 f(z) \}. \end{aligned}$$

If we put

$$g(z) = \frac{d}{dz} \{ z^2 f(z) \},$$

then the equation in $z \neq 0$ is reduced to

$$(18) \quad \frac{dg}{dz} + \left(1 - \frac{1}{z} \right) g(z) = 0.$$

Using the usual solution of a real, linear, inhomogeneous differential equation of first order we at led to guess on the following complete solution of (18):

$$g(z) = C_1 \cdot z e^{-z}.$$

However, we cannot totally rely on the real solution formula in the complex theory, because the principal logarithm occurs latently in the computations. Hence we shall check our guess of solution. On the other hand, this is now trivial. When $g(z)$ is given as above, then

$$g'(z) = C_1(1-z)e^{-z} = C_1 z e^{-z} \cdot \left(\frac{1}{z} - 1\right) = -\left(1 - \frac{1}{z}\right)g(z).$$

ALTERNATIVELY we divide (18) by z , and come back to (16):

$$0 = z \frac{d^2 f}{dz^2} + (z+3) \frac{df}{dz} + 2f(z) = \frac{1}{z} \frac{dg}{dz} + \frac{1}{z} g(z) - \frac{1}{z^2} g(z) = \frac{d}{dz} \left\{ \frac{1}{z} g(z) \right\} + \frac{1}{z} g(z).$$

When we multiply this equation by $e^z \neq 0$, then

$$0 = e^z \frac{d}{dz} \left\{ \frac{g(z)}{z} \right\} + \frac{de^z}{dz} \cdot \left\{ \frac{g(z)}{z} \right\} = \frac{d}{dz} \left\{ \frac{e^z}{z} g(z) \right\} \quad \left(= \frac{d}{dz} \left\{ \frac{e^z}{z} \frac{d}{dz} \{z^2 f(z)\} \right\} \right),$$

hence

$$g(z) = \frac{d}{dz} \{z^2 f(z)\} = C_1 z e^{-z}.$$

When this equation is integrated, we get for $z \neq 0$,

$$z^2 f(z) = -C_1 \cdot (z+1)e^{-z} + C_2,$$

and then finally.

$$f(z) = C_1 \cdot \frac{1 - (1+z)e^{-z}}{z^2} + \frac{C_2 - C_1}{z^2}.$$

A consequence of the above is that if (16) is multiplied by the integrating factor e^z , then it is possible by some manipulations to write the equation in the form

$$\frac{d}{dz} \left\{ \frac{e^z}{z} \frac{d}{dz} [z^2 f(z)] \right\} = 0, \quad z \in \mathbb{C} \setminus \{0\},$$

which immediately can be integrated. We have here made a small detour to find the more obvious integrating factor $z \neq 0$, by which the ideas are presented more clearly than if we immediately had multiplied by the not so obvious factor e^z . \diamond

Example 4.9 Given the differential equation

$$(19) \quad z f''(z) + 4 f'(z) + \left(z + \frac{2}{z}\right) f(z) = 0.$$

1) Assume that the Laurent series

$$f(z) = \sum_{n=-\infty}^{+\infty} a_n z^n$$

is a solution of (19). Find a recursion formula for the coefficients a_n . Then show that $a_n = 0$ for $n \leq -3$.

2) Find all Laurent series solutions of (19) and their domains of convergence.

3) Express the Laurent series solutions of (19) by means of elementary functions.

Alternative solution. The singular point is $z = 0$. Let $z \neq 0$. When we multiply by z , it follows that the equation is equivalent to

$$\begin{aligned} 0 &= z^2 f''(z) + 4z f'(z) + z^2 f(z) + 2f(z) \\ &= \{z^2 f''(z) + 2z f'(z)\} + \{2z f'(z) + 2f(z)\} + z^2 f(z) \\ &= \frac{d}{dz} \{z^2 f'(z)\} + \frac{d}{dz} \{2z f(z)\} + z^2 f(z) \\ &= \frac{d^2}{dz^2} \{z^2 f(z)\} + z^2 f(z), \end{aligned}$$

which is a known differential equation in $g(z) = z^2 f(z)$. The complete solution is

$$g(z) = z^2 f(z) = c_1 \sin z + c_2 \cos z \quad \text{for } z \in \mathbb{C} \setminus \{0\}.$$

Finally,

$$f(z) = c_1 \cdot \frac{\sin z}{z^2} + c_2 \cdot \frac{\cos z}{z^2} \quad \text{for } z \in \mathbb{C} \setminus \{0\}.$$

Only the zero solution can be extended to all of \mathbb{C} .

Standard solution. 1) When we put a formal Laurent series into the differential equation, then

$$\begin{aligned} 0 &= \sum n(n-1)a_n z^{n-1} + \sum 4n a_n z^{n-1} + \sum a_n z^{n+1} + \sum 2a_n z^{n-1} \\ &= \sum \{n^2 - n + 4n + 2\} a_n z^{n-1} + \sum a_n z^{n+1} \\ &= \sum \{(n+1)(n+2)a_n + a_{n-2}\} z^{n-1}. \end{aligned}$$

The *identity theorem* implies the following *recursion formula*,

$$(20) \quad (n+1)(n+2)a_n + a_{n-2} = 0, \quad n \in \mathbb{Z}.$$

If $n = -1$, then $a_{-3} = 0$.

If $n = -2$, then $a_{-4} = 0$.

Then we get by induction,

$$a_n = 0 \quad \text{for } n \leq -3.$$

Finally,

$$a_{n+2} = -\frac{1}{(n+3)(n+4)} a_n \quad \text{for } n > -3.$$

2) If $n = 2p$, $p \in \mathbb{N}_0$, is even, then it follows from (20) that

$$(2p+2)(2p+1)a_{2p} = -a_{2(p-1)}.$$

When we multiply this equation by $(2p)!(-1)^p \neq 0$, it follows by a trivial recursion that

$$(2p+2)!(-1)^p a_{2p} = (2p)!(-1)^{p-1} a_{2(p-1)} = \dots = 0!(-1)a_{-2},$$

hence

$$a_{2p} = \frac{(-1)^{p+1}}{(2p+2)!} a_{-2}, \quad p \in \mathbb{N}_0.$$

gaiteye[®]
Challenge the way we run

**EXPERIENCE THE POWER OF
FULL ENGAGEMENT...**

.....

**RUN FASTER.
RUN LONGER..
RUN EASIER...**

**READ MORE & PRE-ORDER TODAY
WWW.GAITEYE.COM**

Analogously, if $n = 2p + 1$, $p \in \mathbb{N}_0$, is odd, then

$$(2p + 3)(2p + 2)a_{2p+1} = -a_{2p-1} = -a_{2(p-1)+1},$$

hence by a multiplication by $(-1)^p \cdot (2p + 1)! \neq 0$, followed by a simple recursion,

$$(-1)^p (2p + 3)! a_{2p+1} = (-1)^{p-1} (2\{p-1\} + 2)! a_{2(p-1)+1} = \cdots = (-1) \cdot 1! a_{-1},$$

thus

$$a_{2p+1} = \frac{(-1)^{p+1}}{(2p + 3)!} a_{-1}.$$

3) The formal Laurent series solution is for $z \neq 0$ given by

$$\begin{aligned} f(z) &= a_{-1} \sum_{p=1}^{+\infty} \frac{(-1)^{p+1}}{(2p + 3)!} z^{2p+1} + a_{-2} \sum_{p=-1}^{+\infty} \frac{(-1)^{p+1}}{(2p + 2)!} z^{2p} \\ &= a_{-1} \sum_{p=0}^{+\infty} \frac{(-1)^p}{(2p + 1)!} z^{2p-1} + a_{-2} \sum_{p=0}^{+\infty} \frac{(-1)^p}{(2p)!} z^{2p-2} \\ &= a_{-1} \cdot \frac{1}{z^2} \sum_{p=0}^{+\infty} \frac{(-1)^p}{(2p + 1)!} z^{2p+1} + a_{-2} \cdot \frac{1}{z^2} \sum_{p=0}^{+\infty} \frac{(-1)^p}{(2p)!} z^{2p} \\ &= a_{-1} \cdot \frac{\sin z}{z^2} + a_{-2} \cdot \frac{\cos z}{z^2}, \end{aligned}$$

where we have recognized the sum functions of the series. Clearly, the domain of convergence is $\mathbb{C} \setminus \{0\}$, and only the zero solution can be extended to all of \mathbb{C} .

Example 4.10 Given the differential equation

$$(21) \quad (z^2 - z) f''(z) + (4z - 2) f'(z) + 2 f(z) = 0.$$

- 1) We assume that (21) has a Laurent series solution $f(z) = \sum_{n=-\infty}^{+\infty} a_n z^n$. Derive the recursion formula for the coefficients a_n .
- 2) Find all Laurent series solutions of (21) and their domains of convergence.
- 3) Then express each of the Laurent series solutions of (21) by elementary functions.
- 4) Explain why the solutions of (21) all can be extended to \mathbb{C} with the exception of at most two points. Find the type of singularity of each of these points.

First method. *Inspection.* The most important task is of course to find all solutions of (21). We shall here do it by inspection without applying any of the auxiliary questions in the formulation.

The coefficient $z^2 - z = z(z - 1)$ of the term of highest order of differentiation $f''(z)$ is zero at the singular points 0 and 1. Then we reformulate (21) in the following way:

$$\begin{aligned} 0 &= (z^2 - z) f''(z) + (2z - 1) f'(z) + (2z - 1) f'(z) + 2 f(z) \\ &= \frac{d}{dz} \{ (z^2 - z) f'(z) + (2z - 1) f(z) \} = \frac{d^2}{dz^2} \{ (z^2 - z) f(z) \}, \end{aligned}$$

hence by two integrations.

$$(z^2 - z) f(z) = bz - a.$$

If $z \in \mathbb{C} \setminus \{0, 1\}$, we get by a decomposition,

$$f(z) = \frac{bz - a}{z^2 - z} = \frac{bz - a}{z(z - 1)} = \frac{a}{z} + \frac{b - a}{z - 1},$$

where we have trivial analytic extensions if either $a = 0$ or $b = a$.

If $a \neq 0$, then $z = 0$ is a simple pole, and if $b \neq a$, then $z = 1$ is a simple pole.

Second method. *The standard method.*

1) When we by the formal Laurent series into (21), we get

$$\begin{aligned} 0 &= \sum n(n-1)a_n z^n - \sum n(n-1)a_n z^{n-1} \\ &\quad + \sum 4n a_n z^n - \sum 2n a_n z^{n-1} \\ &\quad + \sum 2a_n z^n \\ &= \sum \{n^2 - n + 4n + 2\} a_n z^n - \sum \{n^2 - n + 2n\} a_n z^{n-1} \\ &= \sum (n+1)(n+2)a_n z^n - \sum n(n+1)a_n z^{n-1} \\ &= \sum (n+1)(n+2)a_n z^n - \sum (n+1)(n+2)a_{n+1} z^n \\ &= \sum (n+1)(n+2) \{a_n - a_{n+1}\} z^n. \end{aligned}$$

It follows from the *identity theorem* that we have the *recursion formula*

$$(n+1)(n+2) \{a_n - a_{n+1}\} = 0, \quad n \in \mathbb{Z}.$$

Note in particular that

$$(22) \quad a_n = a_{n+1} \quad \text{for } n \in \mathbb{Z} \setminus \{-1, -2\},$$

while we have no condition for $n = -1$ or $n = -2$ whatsoever.

2) Then solve the recursion formula

$$(n+1)(n+2) \{a_n - a_{n+1}\} = 0. \quad n \in \mathbb{Z}.$$

If $n = -1$, there is no relationship between a_{-1} and a_0 .

If $n = -2$, there is no relationship between a_{-2} and a_{-1} .

If $n > -1$, then we get by recursion of (22) that $a_n = a_0$.

If $n < -2$, then we get by recursion of (22) that $a_n = a_{-2}$.

Hence, all *formal* Laurent series solutions of (21) are given by

$$f(z) = \sum_{n=-\infty}^{+\infty} a_n z^n = a_{-2} \sum_{n=2}^{+\infty} \frac{1}{z^n} + a_{-1} \cdot \frac{1}{z} + a_0 \sum_{n=0}^{+\infty} z^n,$$

and we seemingly have three arbitrary constants of the solution of a linear differential equation of only second order! However, there is nothing wrong here, which follows when we investigate the domains of convergence of each series:

- The series $\sum_{n=2}^{+\infty} \frac{1}{z^n}$ is convergent for $\left|\frac{1}{z}\right| < 1$, i.e. in the open complementary set of the unit disc $|z| > 1$.
- The degenerated Laurent series $\frac{1}{z}$ is convergent for $z \in \mathbb{C} \setminus \{0\}$.
- The series $\sum_{n=0}^{+\infty} z^n$ is convergent in the open unit disc $|z| < 1$.

When we compare these results it follows that a_0 and a_{-2} cannot both be different from zero, so if we want *convergent* series solutions, then we must have $a_0 \cdot a_{-2} = 0$.

We have the following possibilities:

- (a) $f(z) = 0$, $z \in \mathbb{C}$,
- (b) $f(z) = a_{-1} \cdot \frac{1}{z}$, $z \in \mathbb{C} \setminus \{0\}$,
- (c) $f(z) = a_0 \sum_{n=0}^{+\infty} z^n$, $|z| < 1$,
- (d) $f(z) = a_{-1} \cdot \frac{1}{z} + a_0 \sum_{n=0}^{+\infty} z^n$, $0 < |z| < 1$,
- (e) $f(z) = a_{-1} \cdot \frac{1}{z} + a_{-2} \sum_{n=2}^{+\infty} \frac{1}{z^n}$, $|z| > 1$.

This e-book
is made with
SetaPDF

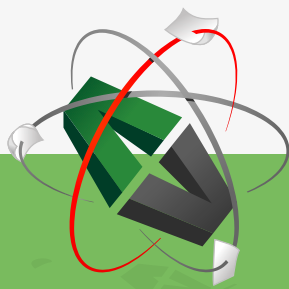

PDF components for **PHP** developers

www.setasign.com



Click on the ad to read more

3) When $|z| < 1$, then of course

$$a_0 \sum_{n=0}^{+\infty} z^n = a_0 \cdot \frac{1}{1-z}, \quad |z| < 1.$$

Analogously when $|z| > 1$,

$$a_{-2} \sum_{n=2}^{+\infty} \frac{1}{z^n} = a_{-2} \cdot \frac{1}{z^2} \cdot \frac{1}{1 - \frac{1}{z}} = a_{-2} \cdot \frac{1}{z(z-1)} = -\frac{a_{-2}}{z} + \frac{a_{-2}}{z-1}.$$

Then these expressions can be put into (c)-(e).

4) We get by insertion into (d),

$$f(z) = a_{-1} \cdot \frac{1}{z} + a_0 \cdot \frac{1}{1-z}, \quad 0 < |z| < 1.$$

Insertion into (e) gives

$$\begin{aligned} f(z) &= a_{-1} \cdot \frac{1}{z} - \frac{a_{-2}}{z} - \frac{a_{-2}}{1-z} \\ &= (a_{-1} - a_{-2}) \cdot \frac{1}{z} + (-a_{-2}) \cdot \frac{1}{1-z}, \quad |z| > 1. \end{aligned}$$

It follows that the general solution has the form by elementary functions,

$$f(z) = A \cdot \frac{1}{z} + B \cdot \frac{1}{1-z},$$

where $f(z)$ *at most* has the simple poles at $z = 0$ and $z = 1$. By either an analytic extension of $f(z)$, or just by checking the differential equation it follows that this function $f(z)$ is a solution of (21) everywhere in its domain.

Example 4.11 Find all Laurent series

$$f(z) = \frac{a_{-1}}{z} + \sum_{n=0}^{+\infty} a_n z^n = \sum_{n=-1}^{+\infty} a_n z^n$$

(expansion from $z_0 = 0$), which are solutions of the differential equation

$$(23) \quad (z^3 - z) f''(z) + (4z^2 - 2) f'(z) + 2z f(z) = 0.$$

Determine the domain of convergence for each of these solutions.

Put $g(z) = z \cdot f(z)$ and express $g'(z)$ explicitly by elementary functions.

Then express all the Laurent series solutions of (23) by means of elementary functions.

First method. INSPECTION. We get by some small manipulations,

$$\begin{aligned} 0 &= (z^3 - z) f''(z) + (4z^2 - 2) f'(z) + 2z f(z) \\ &= (z^3 - z) \frac{d}{dz} f'(z) + (3z^2 - 1) \cdot f'(z) + (z^2 - 1) \frac{d}{dz} f(z) + 2z \cdot f(z) \\ &= \frac{d}{dz} \{ (z^3 - z) f'(z) + (z^2 - 1) f(z) \} = \frac{d}{dz} \{ (z^2 - 1) \cdot \{ z f'(z) + 1 \cdot f(z) \} \} \\ &= \frac{d}{dz} \left\{ (z^2 - 1) \frac{d}{dz} (z f(z)) \right\}. \end{aligned}$$

Then by an integration,

$$(z^2 - 1) \frac{d}{dz} (z f(z)) = C_1, \quad \text{dvs.} \quad \frac{d}{dz} (z f(z)) = \frac{C_1}{z^2 - 1}.$$

If $|z| < 1$, then

$$\frac{d}{dz} \text{Log} \left(\frac{1-z}{1+z} \right) = \frac{1}{\frac{1-z}{1+z}} \cdot \frac{-(1+z) - (1-z)}{(1+z)^2} = \frac{-2}{1-z^2} = \frac{2}{z^2-1},$$

so we conclude that

$$z f(z) = \frac{C_1}{2} \text{Log} \left(\frac{1-z}{1+z} \right) + C_2,$$

and finally,

$$f(z) = \frac{C_1}{2} \cdot \frac{1}{z} \text{Log} \left(\frac{1-z}{1+z} \right) + \frac{C_2}{z}.$$

In general we conclude for the corresponding Laurent series, the derivation of which is postponed to the next variant, that since the singularities are 0 and -1 and 1 , their domain of convergence is $0 < |z| < 1$. For some values of C_1 and C_2 the domain of convergence may be larger. (Again the investigation is postponed to the next variant).

Second method. THE STANDARD METHOD. Assume that $f(z) = \sum_{n=-1}^{+\infty} a_n z^n$ is a Laurent series solution in a domain defined by $0 < |z| < R$. We get by termwise differentiation in this domain

$$f'(z) = \sum_{n=-1}^{+\infty} n a_n z^{n-1} \quad \text{and} \quad f''(z) = \sum_{n=-1}^{+\infty} n(n-1) a_n z^{n-2},$$

hence by insertion into the differential equation,

$$\begin{aligned} 0 &= (z^3 - z) f''(z) + (4z^2 - 2) f'(z) + 2z f(z) \\ &= \sum_{n=-1}^{+\infty} n(n-1) a_n z^{n+1} - \sum_{n=-1}^{+\infty} n(n-1) a_n z^{n-1} + \sum_{n=-1}^{+\infty} 4n a_n z^{n+1} - \sum_{n=-1}^{+\infty} 2n a_n z^{n-1} + \sum_{n=-1}^{+\infty} 2a_n z^{n+1} \\ &= \sum_{n=-1}^{+\infty} \{n^2 + 3n + 2\} a_n z^{n+1} - \sum_{n=-1}^{+\infty} n(n+1) a_n z^{n-1} \\ &= \sum_{n=-1}^{+\infty} (n+1)(n+2) a_n z^{n+1} - \sum_{n=-1}^{+\infty} n(n+1) a_n z^{n-1} \\ &= \sum_{n=-1}^{+\infty} (n+1)(n+2) a_n z^{n+1} - \sum_{n=-1}^{+\infty} (n+2)(n+3) a_{n+2} z^{n+1} \\ &= \sum_{n=-1}^{+\infty} (n+2) \{(n+1) a_n - (n+3) a_{n+2}\} z^{n+1}. \end{aligned}$$

Since $n+2 \neq 0$ for $n \geq -1$, the *recursion formula* is reduced to

$$(24) \quad (n+3) a_{n+2} = (n+1) a_n, \quad n \geq -1,$$

and we see that there is a leap of 2 in the indices.

If $n = 2p - 1$, $p \in \mathbb{N}_0$, then it follows from (24) that

$$(2p+2) a_{2p+1} = 2p \cdot a_{2p-1} = \cdots = 2 \cdot 0 \cdot a_{-1} = 0,$$

hence a_{-1} is an *indeterminate*, and $a_{2p+1} = 0$ for $p \in \mathbb{N}_0$.

If $n = 2p - 2$, $p \in \mathbb{N}$, then it follows from (24) that

$$(2p+1) a_{2p} = (2p-1) a_{2p-2} = \cdots = 1 \cdot a_0,$$

hence

$$a_{2n} = \frac{a_0}{2n+1} \quad \text{for } n \in \mathbb{N}_0,$$

and a_0 is also *arbitrary*. Therefore, all possible Laurent series solutions are given by

$$(25) \quad f(z) = \frac{a_{-1}}{z} + a_0 \sum_{n=0}^{+\infty} \frac{z^{2n}}{2n+1}, \quad a_{-1}, a_0 \in \mathbb{C}.$$

If $a_{-1} = 0$ and $a_0 = 0$, then $f(z) \equiv 0$, the domain of which is all of \mathbb{C} .

If $a_{-1} \neq 0$ and $a_0 = 0$, then $f(z) = \frac{a_{-1}}{z}$, the domain of which is $\mathbb{C} \setminus \{0\}$.

If $a_{-1} = 0$ and $a_0 \neq 0$, then

$$f(z) = a_0 \sum_{n=0}^{+\infty} \frac{z^{2n}}{2n+1},$$

the domain of which is $\{z \in \mathbb{C} \mid |z| < 1\}$.

If both $a_{-1} \neq 0$ and $a_0 \neq 0$, then the Laurent series is convergent in the open unit disc $\{z \in \mathbb{C} \mid 0 < |z| < 1\}$ with the centrum removed, which we expected, because the differential equation has the singular points $-1, 0$ and 1 . (These are the zeros of the coefficient $z^3 - z$ of $f''(z)$).

If we exclude all the exception cases, it follows in general from (25) that

$$g(z) = z \cdot f(z) = a_1 - +a_0 \sum_{n=0}^{+\infty} \frac{z^{2n+1}}{2n+1}, \quad 0 \leq |z| < 1,$$

hence

$$g'(z) = a_0 \sum_{n=0}^{+\infty} z^{2n} = \frac{a_0}{1-z^2} = -\frac{a_0}{2} \left\{ \frac{1}{z-1} - \frac{1}{z+1} \right\}, \quad |z| < 1.$$



www.sylvania.com

**We do not reinvent
the wheel we reinvent
light.**

Fascinating lighting offers an infinite spectrum of possibilities: Innovative technologies and new markets provide both opportunities and challenges. An environment in which your expertise is in high demand. Enjoy the supportive working atmosphere within our global group and benefit from international career paths. Implement sustainable ideas in close cooperation with other specialists and contribute to influencing our future. Come and join us in reinventing light every day.

Light is OSRAM

**OSRAM
SYLVANIA** 



When $|z| < 1$, then both $1 - z$ and $1 + z$ lie in the domain of the principal logarithm, and we have

$$\operatorname{Arg}(1 - z), \operatorname{Arg}(1 + z) \in \left] -\frac{\pi}{2}, \frac{\pi}{2} \right[.$$

Hence

$$g(z) = a_{-1} - \frac{a_0}{2} \operatorname{Log}(1 - z) + \frac{a_0}{2} \operatorname{Log}(1 + z) = a_{-1} + \frac{a_0}{2} \operatorname{Log} \left(\frac{1 + z}{1 - z} \right),$$

and thus

$$\begin{aligned} f(z) &= \frac{a_{-1}}{z} + \frac{a_0}{2z} \operatorname{Log} \left(\frac{1 + z}{1 - z} \right) = \frac{a_{-1}}{z} - \frac{a_0}{2z} \operatorname{Log} \left(\frac{1 - z}{1 + z} \right) \\ &= \frac{a_{-1}}{z} + \frac{a_0}{2z} \operatorname{Log}(1 + z) - \frac{a_0}{2z} \operatorname{Log}(1 - z), \end{aligned}$$

for $0 < |z| < 1$.

Third method. INTUITION. By reading the text of the example we see that $g(z) = z f(z)$ occurs somewhere as an auxiliary function. This is a latent hint of reformulating the differential equation as an equation in $g(z)$ instead. We get

$$g(z) = z f(z), \quad g'(z) = z f'(z) + f(z), \quad g''(z) = z f''(z) + 2 f'(z),$$

hence

$$\begin{aligned} 0 &= (z^2 - 1) z f''(z) + (4z^2 - 2) f'(z) + 2z f(z) \\ &= (z^2 - 1) \{z f''(z) + 2 f'(z)\} + \{4z^2 - 2 - 2z^2 + 2\} f'(z) + 2z f(z) \\ &= (z^2 - 1) g''(z) + 2z \{z f'(z) + f(z)\} = (z^2 - 1) g''(z) + 2z g'(z) \\ &= \frac{d}{dz} \{(z^2 - 1) g'(z)\}. \end{aligned}$$

It follows immediately that

$$(z^2 - 1) g'(z) = C_1.$$

Then we may proceed as in the FIRST METHOD. However, to demonstrate another VARIANT, we expand $-\frac{C_1}{1 - z^2}$ as a series in the open unit disc $|z| < 1$ followed by an integration. Then for $|z| < 1$,

$$g'(z) = -\frac{C_1}{1 - z^2} = -C_1 \sum_{n=0}^{+\infty} z^{2n},$$

hence

$$g(z) = z \cdot f(z) = C_2 - C_1 \sum_{n=0}^{+\infty} \frac{1}{2n + 1} z^{2n+1}, \quad |z| < 1,$$

and thus

$$f(z) = \frac{C_2}{z} - C_1 \sum_{n=0}^{+\infty} \frac{1}{2n + 1} z^{2n}, \quad 0 < |z| < 1.$$

We must of course integrate $\frac{1}{1 - z^2}$ directly (cf. the two previous methods).

5 Isolated boundary points

Example 5.1 Describe the type of singularity at $z_0 = 0$ of the function $f(z) = \frac{\sin z}{z}$, $z \in \mathbb{C} \setminus \{0\}$.

The function $f(z)$ has a *removable singularity* at $z_0 = 0$. In fact, we get by a series expansion that

$$f(z) = \frac{\sin z}{z} = \frac{1}{z} \sum_{n=0}^{+\infty} \frac{(-1)^n}{(2n+1)!} z^{2n+1} = 1 - \frac{z^2}{3!} + \frac{z^4}{5!} - \dots \quad \text{for } z \neq 0.$$

Clearly, the function can be extended analytically to $z = 0$ by $f(0) = 1$, so

$$f^*(z) = \begin{cases} \frac{\sin z}{z}, & \text{for } z \in \mathbb{C} \setminus \{0\}, \\ 1, & \text{for } z = 0, \end{cases}$$

is analytic.

Example 5.2 Describe the type of singularity at $z_0 = 0$ of the function $f(z) = \exp(1/z^2)$, $z \in \mathbb{C} \setminus \{0\}$.

It follows by a Laurent series expansion from $z_0 = 0$ that

$$f(z) = \exp\left(\frac{1}{z^2}\right) = \sum_{n=0}^{+\infty} \frac{1}{n!} \{1/z^2\}^n = \sum_{n=0}^{+\infty} \frac{1}{n!} \frac{1}{z^{2n}}, \quad z \in \mathbb{C} \setminus \{0\}.$$

Since $a_{-2n} = \frac{1}{n!} \neq 0$ for all $n \in \mathbb{N}_0$, i.e. for infinitely many negative indices, the singularity is an *essential singularity*.

ALTERNATIVELY we choose the two sequences

$$z'_n = \frac{1}{n} \rightarrow 0 \quad \text{for } n \rightarrow +\infty, \quad \text{and} \quad z''_n = \frac{i}{n} \rightarrow 0 \quad \text{for } n \rightarrow +\infty.$$

When we take the limit $n \rightarrow +\infty$ we get respectively,

$$f(z'_n) = \exp(n^2) \rightarrow \infty \quad \text{and} \quad f(z''_n) = \exp(-n^2) \rightarrow 0.$$

Thus we have two different limit values for two different sequences, both converging towards the singularity, and we conclude that we have an *essential singularity*.

Example 5.3 Describe the singularities of the function

$$f(z) = \frac{1}{\sin z}, \quad \text{for } z \in \mathbb{C} \setminus \{p\pi \mid p \in \mathbb{Z}\}.$$

It follows from

$$\lim_{z \rightarrow p\pi} \frac{d}{dz} \sin z = \lim_{z \rightarrow p\pi} \cos z = (-1)^p \neq 0 \quad \text{for every } p \in \mathbb{Z},$$

that the denominator $\sin z$ has *simple zeros* for $z = p\pi$, $p \in \mathbb{Z}$, i.e. $f(z) = \frac{1}{\sin z}$ has *simple poles* at the same points. Notice that since $p\pi \rightarrow \infty$ for $p \rightarrow +\infty$, we do *not* have ∞ as an isolated singularity of $f(z)$.

Example 5.4 *Indicate the order of the pole at $z = 0$ of*

$$(\sin z + \sinh z - 2z)^{-2}.$$

Determining the order of the pole at $z = 0$ of

$$(\sin z + \sinh z - 2z)^{-2},$$

is the same as determining the order of the zero at $z = 0$ of

$$(\sin z + \sinh z - 2z)^2.$$

It follows by a series expansion that

$$\begin{aligned} \sin z + \sinh z - 2z &= \left\{ z - \frac{z^3}{3!} + \frac{z^5}{5!} + \cdots \right\} + \left\{ z + \frac{z^3}{3!} + \frac{z^5}{5!} + \cdots \right\} - 2z \\ &= \frac{2z^5}{5!} + \cdots = \frac{1}{60} z^5 \{1 + \cdots\}, \end{aligned}$$

so $f(z) = \sin z + \sinh z - 2z$ has a zero of order five at $z = 0$. Hence we conclude that

$$(\sin z + \sinh z - 2z)^{-2},$$

has a pole of order $2 \cdot 5 = 10$ at $z = 0$.

Example 5.5 *Find the type of the singular points in \mathbb{C} of*

$$(a) f(z) = \frac{1}{e^z - 1}, \quad (b) \frac{z(z - \pi)^2}{\sin^2 z}.$$

(a) The denominator is $\varphi(z) = e^z - 1 = 0$ for $z = 2ip\pi$, $p \in \mathbb{Z}$, and

$$\varphi'(z) = e^z = 1 \quad \text{for } z = 2ip\pi, \quad p \in \mathbb{Z}.$$

Hence we conclude that $\varphi(z)$ has simple zeros for $z = 2ip\pi$, $p \in \mathbb{Z}$, i.e.

$$f(z) = \frac{1}{\varphi(z)} = \frac{1}{e^z - 1}$$

has simple poles for $z = 2ip\pi$, $p \in \mathbb{Z}$.

(b) Since $\sin z = 0$ for $z = p\pi$, $p \in \mathbb{Z}$, where all these are simple zeros, we conclude that

1. $z = 0$ is a simple pole of $\frac{z(z - \pi)^2}{\sin^2 z}$;
2. $z = \pi$ is a removable singularity of $\frac{z(z - \pi)^2}{\sin^2 z}$;
3. $z = p\pi$, $p \in \mathbb{Z} \setminus \{0, 1\}$, are double poles of $\frac{z(z - \pi)^2}{\sin^2 z}$.

Example 5.6 Indicate the type of the singular points in \mathbb{C} of

$$(a) \frac{z^2 - 1}{z^2 + 1}, \quad (b) \frac{1}{z - z^3}, \quad (c) \frac{z^4}{1 + z^4}.$$

(a) The function

$$\frac{z^2 - 1}{z^2 + 1} = 1 - \frac{2}{z^2 + 1}$$

has simple poles for $z = \pm i$.

(b) The denominator has the simple zeros $z = -1, 0, 1$, so $z = -1, 0, 1$, are simple poles of

$$f(z) = \frac{1}{z - z^3}.$$

(c) It follows from

$$f(z) = \frac{z^4}{1 + z^4} = 1 - \frac{1}{1 + z^4},$$

that $f(z)$ has the simple poles

$$\frac{1}{\sqrt{2}} + \frac{i}{\sqrt{2}}, \quad \frac{1}{\sqrt{2}} - \frac{i}{\sqrt{2}}, \quad -\frac{1}{\sqrt{2}} + \frac{i}{\sqrt{2}}, \quad -\frac{1}{\sqrt{2}} - \frac{i}{\sqrt{2}}.$$



Discover the truth at www.deloitte.ca/careers

Deloitte.

© Deloitte & Touche LLP and affiliated entities.



Example 5.7 Indicate the type of the singular points in \mathbb{C} of

$$(a) \frac{1}{z(z^2 + 4)^2}, \quad (b) \frac{z^3 + 5}{(z^4 - 1)(z + 1)}.$$

(a) Clearly, $z = 0$ is a simple pole, and $z = \pm 2i$ are double poles.

(b) The function

$$f(z) = \frac{z^3 + 5}{(z^4 - 1)(z + 1)}$$

has the three simple poles $1, i$ and $-i$, and the double pole -1 .

Example 5.8 Given

$$F(z) = \exp\left(\frac{1}{z-1}\right) \quad \text{for } z \in \mathbb{C} \setminus \{1\}.$$

Indicate the type of the singularity at $z_0 = 1$, and find $\text{res}(F(z); 1)$.

Describe for every constant $\alpha > 0$ the set of points $z \in \mathbb{C} \setminus \{1\}$, for which $|F(z)| = \alpha$. Show in particular on a figure the set

$$\{z \in \mathbb{C} \setminus \{1\} \mid |F(z)| = \alpha\}$$

for representative values of $\alpha > 0$.

Prove by choosing $\alpha > 0$ conveniently that $F(z)$ is bounded for $|z| < 1$, and indicate the smallest constant $C > 0$, for which

$$|F(z)| \leq C \quad \text{for } |z| < 1.$$

It follows by a series expansion from $z_0 = 1$ that

$$(26) \quad F(z) = \exp\left(\frac{1}{z-1}\right) = \sum_{n=0}^{+\infty} \frac{1}{n!} \left(\frac{1}{z-1}\right)^n = \sum_{n=0}^{+\infty} \frac{1}{n!} \cdot \frac{1}{(z-1)^n}, \quad z \in \mathbb{C} \setminus \{1\}.$$

Then by the classification of the isolated singularities,

$$a_{-n} = \frac{1}{n!} \neq 0 \quad \text{for all } n \in \mathbb{N}_0,$$

and we are in case III, i.e. $z_0 = 1$ is an *essential singularity*.

It follows from the series expansion (26) that

$$\text{res}(F(z); 1) = a_{-1} = \frac{1}{1!} = 1.$$

If $z = x + iy \neq 1$, then

$$\frac{1}{z-1} = \frac{1}{x-1+iy} = \frac{x-1}{(x-1)^2+y^2} - i \cdot \frac{y}{(x-1)^2+y^2},$$

hence

$$|F(z)| = \exp\left(\operatorname{Re}\left\{\frac{1}{z-1}\right\}\right) = \exp\left(\frac{x-1}{(x-1)^2+y^2}\right), \quad z \neq 1.$$

Thus the equation $|F(z)| = \alpha$ for $\alpha > 0$ and $z \neq 1$ can be written

$$\exp\left(\frac{x-1}{(x-1)^2+y^2}\right) = \alpha, \quad (x, y) \neq (1, 0),$$

which is equivalent to

$$(27) \quad \frac{x-1}{(x-1)^2+y^2} = \ln \alpha, \quad \ln \alpha \in \mathbb{R}, \quad (x, y) \neq (1, 0).$$

If $\alpha = 1$, then $\ln \alpha = 0$, hence $x = 1$. We have furthermore required that $(x, y) \neq (1, 0)$, so $y \neq 0$, and we end up with two half lines.

If $\alpha \in \mathbb{R}_+ \setminus \{1\}$, then $\ln \alpha \neq 0$. We get by a rearrangement of (27) that

$$(x-1)^2 + y^2 = \frac{1}{\ln \alpha} \cdot (x-1), \quad (x, y) \neq (1, 0),$$

hence

$$(x-1)^2 - 2 \cdot \frac{1}{2 \ln \alpha} (x-1) + \left(\frac{1}{2 \ln \alpha}\right)^2 + y^2 = \left(\frac{1}{2 \ln \alpha}\right)^2$$

for $(x, y) \neq (1, 0)$, which we also write as

$$\left(x-1 - \frac{1}{\ln(\alpha^2)}\right)^2 + y^2 = \left\{\frac{1}{\ln(\alpha^2)}\right\}^2, \quad \alpha \neq 1, \quad (x, y) \neq (1, 0).$$

This is a circle where the point $(1, 0)$ has been removed with centrum and radius respectively,

$$\left(1 + \frac{1}{\ln(\alpha^2)}, 0\right) \quad \text{and} \quad \frac{1}{|\ln(\alpha^2)|},$$

where one must not forget the numerical sign of the radius > 0 .

The natural extensions of all these circles are all passing through the singular point $(1, 0)$. Hence, the family of curves can also be described as all circles in the plane through the point $(1, 0)$ and of centrum on the x -axis, supplied with the vertical line $x = 1$, where we remove the common point $(1, 0)$ from all curves.

If

$$1 + \frac{1}{\ln(\alpha^2)} = 0,$$

i.e. $\ln(\alpha^2) = -1$, or in other words,

$$\alpha = \frac{1}{\sqrt{e}},$$

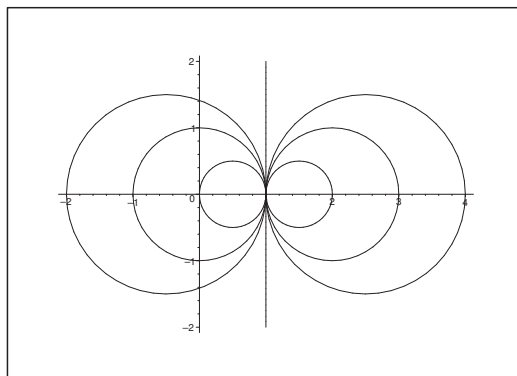
Figure 7: Some of the level curves $|F(z)| = \alpha$.

we precisely obtain the unit circle (with the exception of the singular point $(1, 0)$).

If $\alpha < \frac{1}{\sqrt{e}}$, then

$$\ln(\alpha^2) < \ln \frac{1}{e} = -1,$$

hence $|\ln(\alpha^2)| > 1$, and the radius is

$$r = \frac{1}{|\ln(\alpha^2)|} < 1,$$

and the x -coordinate of the centrum is

$$1 + \frac{1}{\ln(\alpha^2)} \in]0, 1[.$$

When α runs through the interval

$$0 < \alpha < \frac{1}{\sqrt{e}},$$

this corresponds to that we run through all circles of the considered type (with the exception of the point $(1, 0)$) contained in the unit disc.

It follows that every z , $|z| < 1$ in the open unit disc lies on precisely one of the curves

$$|F(z)| = \alpha,$$

corresponding to a uniquely determined

$$\alpha \in \left] 0, \frac{1}{\sqrt{e}} \right[.$$

We conclude that $C = \frac{1}{\sqrt{e}}$ is the smallest constant, for which

$$|F(z)| = \left| \exp\left(\frac{1}{z-1}\right) \right| \leq C \quad \text{for } |z| < 1,$$

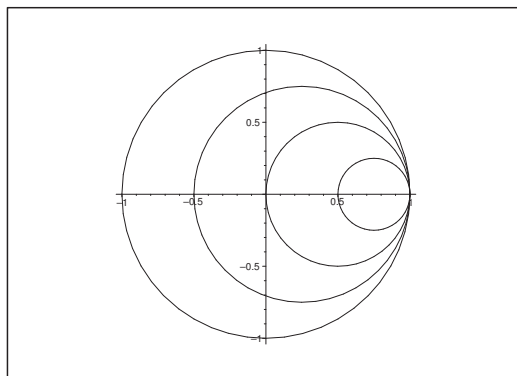

Figure 8: The curves $|F(\alpha)| = \alpha$ for $0 < \alpha < \frac{1}{\sqrt{e}}$ fill in all of the open unit disc.

hence

$$|F(z)| = \left| \exp\left(\frac{1}{z-1}\right) \right| < \frac{1}{\sqrt{e}} \quad \text{for } |z| < 1.$$

SIMPLY CLEVER

ŠKODA



We will turn your CV into
an opportunity of a lifetime



Do you like cars? Would you like to be a part of a successful brand?
We will appreciate and reward both your enthusiasm and talent.
Send us your CV. You will be surprised where it can take you.

Send us your CV on
www.employerforlife.com



Click on the ad to read more

Remark 5.1 We should of course compare this result with *Picard's theorem* which says that the function $\exp\left(\frac{1}{z-1}\right)$ takes on any value of $\mathbb{C} \setminus \{0\}$ in any neighbourhood of $z_0 = 1$. Nevertheless, it is seen that the function is limited at any point in a neighbourhood of $z_0 = 1$, which also lies in the open unit disc. \diamond

Example 5.9 Given the Laurent series

$$\sum_{n=-\infty}^{+\infty} \frac{z^n}{2^{|n|}}.$$

Find the domain of convergence Ω and the sum function f of this series. Then find the value of the complex line integral

$$\oint_{|z|=1} f(z) dz.$$

We start by writing the Laurent series as a sum of two geometric series:

$$\sum_{n=-\infty}^{+\infty} \frac{z^n}{2^{|n|}} = \sum_{n=0}^{+\infty} \left(\frac{z}{2}\right)^n + \sum_{n=-\infty}^{-1} (2z)^n = \sum_{n=0}^{+\infty} \left(\frac{z}{2}\right)^n + \sum_{m=1}^{+\infty} \left(\frac{1}{2z}\right)^m = \sum_{n=0}^{+\infty} \left(\frac{z}{2}\right)^n + \frac{1}{2z} \sum_{n=0}^{+\infty} \left(\frac{1}{2z}\right)^n.$$

The conditions of convergence are $\left|\frac{z}{2}\right| < 1$ and $\left|\frac{1}{2z}\right| < 1$, so we conclude that the domain of convergence is

$$\Omega = \left\{ z \in \mathbb{C} \mid \frac{1}{2} < |z| < 2 \right\}.$$

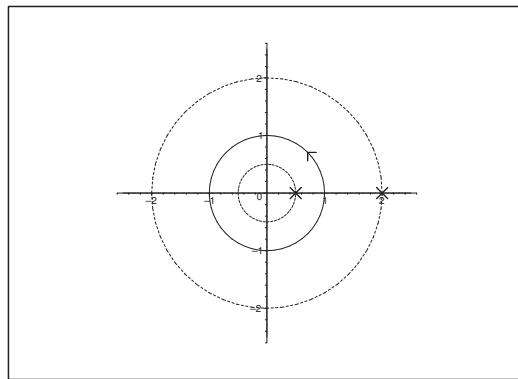

Figure 9: The domain Ω lies between the two circles, where the singularities $\frac{1}{2}$ and 2 have been marked and with the path of integration $|z| = 1$ indicated.

The sum function is in Ω given by expansions of the geometric series given by

$$f(z) = \frac{1}{1 - \frac{z}{2}} + \frac{1}{2z} \frac{1}{1 - \frac{1}{2z}} = \frac{2}{2-z} + \frac{1}{2z-1} = \frac{3z}{(2-z)(2z-1)}.$$

The value of the line integral is obtained by Laurent's theorem, because the coefficient of z^{-1} is $\frac{1}{2}$, and because we integrate along a closed simple curve in Ω , which separates the two boundary circles,

$$\oint_{|z|=1} f(z) dz = 2\pi i \cdot a_{-1} = \pi i.$$

ALTERNATIVELY we may apply Cauchy's integral theorem and integral formula:

$$\oint_{|z|=1} f(z) dz = \oint_{|z|=1} \frac{2}{2-z} dz + \oint_{|z|=1} \frac{\frac{1}{2}}{z-\frac{1}{2}} dz = 0 + 2\pi i \cdot \frac{1}{2} = \pi i.$$

Example 5.10 Given

$$f(z) = \frac{z^4 \exp(1/z)}{z^2 + 1}.$$

Find the singularities of $f(z)$ and indicate their type.
Then compute the line integral

$$\oint_C f(z) dz,$$

where C is the circle $|z - 2i| = \sqrt{2}$ of positive direction.

It follows from

$$f(z) = \frac{z^4 \exp(1/z)}{z+i)(z-i)} = z^2 \frac{\exp \frac{1}{z}}{1 + \left(\frac{1}{z}\right)^2}$$

that the singularities are

$z = i,$	pole of first order,
$z = -i,$	pole of first order,
$z = \infty,$	pole of second order,
$z = 0,$	essential singularity.

The given circle surrounds precisely one of the singularities. We compute the integral by the residue theorem. The pole at $z = i$ is simple, so

$$\operatorname{res}(f(z); i) = \left[\frac{z^4 \exp \frac{1}{z}}{2z} \right]_{z=i} = \frac{1}{2i} e^{-i},$$

and hence

$$\oint_C f(z) dz = 2\pi i \cdot \frac{1}{2i} e^{-i} = \pi e^{-i} = \pi(\cos 1 - i \sin 1).$$

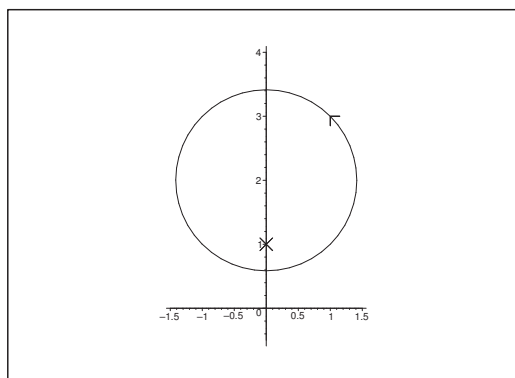

Figure 10: The curve C with its direction and with the singularity $z = i$ inside.

Example 5.11 Given the functions

$$f(z) = \frac{1}{z^2(2-z)} \quad \text{and} \quad g(z) = \frac{\sin(\pi z)}{z^2(2-z)}.$$

- 1) Indicate the isolated singularities and their types of f and g in \mathbb{C} .
- 2) Find the Laurent series of f in the annulus $0 < |z| < 2$ and in the set $2 < |z|$.
- 3) Find the terms $\frac{b_1}{z} + a_0 + a_1 z$ of the Laurent series of g in the annulus $0 < |z| < 2$.
- 4) Explain why the function $h(z) = z g(z)$ can be represented by a power series of radius of convergence $R = +\infty$. (One shall not find the general term of the power series).

1) The function

$$f(z) = \frac{1}{z^2(2-z)}$$

is a rational function with a double pole at $z = 0$ and a simple pole at $z = 2$ (and also a zero of order 3 at ∞).

The function

$$g(z) = \frac{\sin(\pi z)}{z^2(2-z)} = \sin(\pi z) \cdot f(z)$$

has the same (finite) singularities as $f(z)$. However, their types are different, because $z = 0$ and $z = 2$ are both simple zeros of the numerator. This implies that $z = 0$ is a simple pole of $g(z)$, and that $z = 2$ is a removable singularity of $g(z)$.

2) In the annulus $0 < |z| < 2$, we get the Laurent series expansion

$$\begin{aligned} f(z) &= \frac{1}{z^2(2-z)} = \frac{1}{2z^2} \cdot \frac{1}{1-\frac{z}{2}} = \frac{1}{2z^2} \sum_{n=0}^{+\infty} \frac{1}{2^n} z^n \\ &= \sum_{n=0}^{+\infty} \frac{1}{2^{n+1}} z^{n-2} = \sum_{n=-2}^{+\infty} \frac{1}{2^{n+3}} z^n, \quad \text{for } 0 < |z| < 2, \end{aligned}$$

where we have used that $\left|\frac{z}{2}\right| < 1$. It follows that

$$a_n = \frac{1}{2^{n+3}} \quad \text{for } n \geq -2, \quad \text{and } 0 \text{ otherwise.}$$

I joined MITAS because
I wanted **real responsibility**

The Graduate Programme
for Engineers and Geoscientists
www.discovermitas.com



Month 16

I was a construction
supervisor in
the North Sea
advising and
helping foremen
solve problems

Real work
International opportunities
Three work placements



 **MAERSK**



If instead $|z| > 2$, then

$$\begin{aligned} f(z) &= \frac{1}{z^2(2-z)} = -\frac{1}{z^3} \cdot \frac{1}{1-\frac{2}{z}} = -\frac{1}{z^3} \sum_{n=0}^{+\infty} 2^n \cdot \frac{1}{z^n} = -\sum_{n=0}^{+\infty} 2^n \cdot \frac{1}{z^{n+3}} \\ &= -\sum_{n=3}^{+\infty} 2^{n-3} \cdot \frac{1}{z^n}, \quad \text{for } |z| > 2, \end{aligned}$$

because $\left|\frac{2}{z}\right| < 1$. Hence,

$$a_{-n} = b_n = -2^{n-3} \quad \text{for } n \geq 3, \quad \text{and 0 otherwise.}$$

3) Since $g(z)$ has a simple pole at $z = 0$, the Laurent series of $g(z)$ is in the domain $0 < |z| < 2$ given by

$$\begin{aligned} g(z) &= \frac{b_1}{z} + a_0 + a_1z + \dots = \left\{ \frac{1}{2} \frac{1}{z^2} + \frac{1}{4} \frac{1}{z} + \frac{1}{8} + \dots \right\} \left\{ \pi z - \frac{1}{6} \pi^3 z^3 + \dots \right\} \\ &= \frac{\pi}{2} \cdot \frac{1}{z} + \frac{\pi}{4} + \left\{ \frac{\pi}{8} - \frac{\pi^3}{12} \right\} z + \dots, \end{aligned}$$

hence

$$\frac{b_1}{z} + a_0 + a_1z = \frac{\pi}{2} \cdot \frac{1}{z} + \frac{\pi}{4} + \left\{ \frac{\pi}{8} - \frac{\pi^3}{12} \right\} z.$$

4) The function

$$h(z) = z g(z) = \frac{\sin(\pi z)}{z(z-2)}$$

has the singularities at $z = 0$ and $z = 2$, and they can both be removed. Hence we can extend $h(z)$ analytically to all of \mathbb{C} , so the Taylor series is convergent in all of \mathbb{C} . Note that the sum function of the Taylor series is rather complicated. so that is why it is not requested here. The extension to all of \mathbb{C} is

$$H(z) = \begin{cases} \frac{\sin(\pi z)}{z(2-z)} & \text{for } z \in \mathbb{C} \setminus \{0, 2\}, \\ \frac{\pi}{2} & \text{for } z = 0, \\ -\frac{\pi}{2} & \text{for } z = -2. \end{cases}$$

Example 5.12 Given the function

$$f(z) = \frac{z^2 - 1}{\cos(\pi z) + 1}.$$

- 1) Find all the isolated singularities of f in \mathbb{C} , and indicate their type.
- 2) Find the radius of convergence of the Maclaurin series of f without determining the coefficients. Find the coefficients a_0, a_1, a_2 and the Maclaurin series of f .

- 1) The isolated singularities are given by the equation

$$\cos(\pi z) + 1 = 0, \quad \text{i.e. } \pi z = \pi + 2p\pi, \quad p \in \mathbb{Z},$$

thus

$$z_p = 2p + 1, \quad p \in \mathbb{Z}.$$

These are all at most poles of second order.

If $p = 0$, then $z_0 = 1$ is also a zero of the numerator.

If $p = -1$, then $z_{-1} = -1$ is also a zero of the numerator.

We conclude that $z_0 = 1$ and $z_{-1} = -1$ are simple poles.

Since

$$\frac{d^2}{dz^2} \{\cos(\pi z) + 1\}|_{z=z_p} \neq 0,$$

any other singularity must be a pole of second order.

- 2) The closest singularities of 0, are $z_0 = 1$ and $z_{-1} = -1$. They both have the distance 1 to 0, so the radius of convergence is $R = 1$.

If $|z| < 1$, then

$$f(z) = \frac{z^2 - 1}{\cos(\pi z) + 1} = a_0 + a_1 z + a_2 z^2 + \dots,$$

and we conclude immediately that $a_1 = 0$, because $f(z)$ is an *even* function. If one does not see this, we may still perform the following calculation, where we multiply by the denominator,

$$z^2 - 1 = \{a_0 + a_1 z + a_2 z^2 + \dots\} \left\{2 - \frac{\pi^2}{2} z^2 + \dots\right\} = 2a_0 + 2a_1 z + \left(2a_2 - \frac{\pi^2}{2} a_0\right) z^2 + \dots.$$

Then by identification of the coefficients,

$$a_0 = -\frac{1}{2}, \quad a_1 = 0, \quad a_2 = \frac{\pi^2}{4} a_0 = -\frac{\pi^2}{8}.$$

6 The conditions around the point at ∞

Example 6.1 Indicate the type of the singular points in $\mathbb{C} \cup \{\infty\}$ of

$$(a) \frac{2}{(z-3)^2} + \frac{1}{z-3} + e^z, \quad (b) \frac{\cos z}{z - \frac{\pi}{2}}.$$

(a) The function

$$f(z) = \frac{2}{(z-3)^2} + \frac{1}{z-3} + e^z$$

has a double pole at $z = 3$ and an essential singularity at ∞ .

(b) The function

$$f(z) = \frac{\cos z}{z - \frac{\pi}{2}}$$

has a removable singularity at $z = \frac{\pi}{2}$, where

$$f\left(\frac{\pi}{2}\right) = \lim_{z \rightarrow \frac{\pi}{2}} \frac{\cos z}{z - \frac{\pi}{2}} = \lim_{z \rightarrow \frac{\pi}{2}} \frac{-\sin z}{1} = -1,$$

and an essential singularity at ∞ .

Example 6.2 Indicate the type of the singular points in $\mathbb{C} \cup \{\infty\}$ of

$$(a) \sin z + \sin \frac{1}{z}, \quad (b) \frac{\sin z}{z^3}.$$

(a) The function

$$f(z) = \sin z + \sin \frac{1}{z}$$

has only essential singularities at 0 and at ∞ .

(b) The function

$$f(z) = \frac{\sin z}{z^3}$$

has a double pole (notice, not a triple pole) at $z=0$, and an essential singularity at ∞ . In fact, $\sin z$ has a simple zero at $z = 0$, which will lower the order of the pole by 1.

Example 6.3 Indicate the type of the singular points in $\mathbb{C} \cup \{\infty\}$ of

$$(a) \frac{1}{\cos \frac{1}{z}}, \quad (b) \frac{1 - \cos z}{z^6}.$$

(a) The function

$$f(z) = \frac{1}{\cos \frac{1}{z}}$$

has simple poles for

$$\frac{1}{z} = \frac{\pi}{2} + p\pi = \frac{\pi}{2}(2p+1),$$

i.e. for

$$z_p = \frac{2}{\pi(2p+1)}, \quad p \in \mathbb{Z}.$$

ie business school

#1 EUROPEAN BUSINESS SCHOOL
FINANCIAL TIMES 2013

#gobeyond

MASTER IN MANAGEMENT

Because achieving your dreams is your greatest challenge. IE Business School's Master in Management taught in English, Spanish or bilingually, trains young high performance professionals at the beginning of their career through an innovative and stimulating program that will help them reach their full potential.

- Choose your area of specialization.
- Customize your master through the different options offered.
- Global Immersion Weeks in locations such as London, Silicon Valley or Shanghai.

Because you change, we change with you.

www.ie.edu/master-management | mim.admissions@ie.edu |



We note that 0 is not an isolated singularity, because $z_p \rightarrow 0$ for $p \rightarrow +\infty$, and for $p \rightarrow -\infty$, i.e. 0 is an essential (non-isolated) singularity.

It follows from

$$\lim_{z \rightarrow \infty} \frac{1}{\cos \frac{1}{z}} = \frac{1}{\cos 0} = 1,$$

that ∞ is a removable singularity.

(b) Here $1 - \cos z$ has a zero of second order at $z = 0$, so the function

$$f(z) = \frac{1 - \cos z}{z^6}$$

has a fourfold pole at $z = 0$.

Finally, ∞ is an essential singularity.

Example 6.4 Indicate the type of the singular points in $\mathbb{C} \cup \{\infty\}$ of

$$(a) \frac{\cos z}{z}, \quad (b) \frac{e^z - 1}{z(z-1)}.$$

(a) We see that $z = 0$ is a simple pole of

$$\frac{\cos z}{z},$$

and furthermore that ∞ is an essential singularity.

(b) The function

$$\frac{e^z - 1}{z(z-1)}$$

has a removable singularity at $z = 0$, a simple pole at $z = 1$, and an essential singularity at $z = \infty$.

Example 6.5 Indicate the type of the singular points in $\mathbb{C} \cup \{\infty\}$ of

$$(a) \frac{z^5}{z^3 + z}, \quad (b) e^{\cosh z}.$$

(a) It is immediately seen that

$$\frac{z^5}{z^3 + z} = \frac{z^5}{z(z^2 + 1)} = \frac{z^5}{z(z-i)(z+i)} = \frac{z^2}{1 + \frac{1}{z^2}}$$

has a removable singularity at $z = 0$, simple poles at $z = \pm i$, and a double pole at ∞ .

(b) The function $e^{\cosh z}$ has only an essential singularity at ∞ .

Example 6.6 Indicate the type of the singular points in $\mathbb{C} \cup \{\infty\}$ of

$$(a) \frac{e^z}{1+z^2}, \quad (b) \frac{z^2+1}{e^z}.$$

(a) It follows immediately that $z = \pm i$ are simple poles and that $z = \infty$ is an essential singularity.

(b) The function

$$(z^2+1)e^{-z} = (1+z^2) \sum_{n=0}^{+\infty} \frac{(-1)^n}{n!} z^n = 1 - z + \sum_{n=2}^{+\infty} (-1)^n \left\{ \frac{1}{n!} + \frac{1}{(n-2)!} \right\} z^n$$

has an essential singularity at ∞ . It does not have any other singularity.

Example 6.7 Indicate the type of the singular points in $\mathbb{C} \cup \{\infty\}$ of

$$(a) z e^{-z}, \quad (b) \frac{z^5}{(1-z)^2}, \quad (c) \cos z - \frac{1}{z}.$$

(a) The only singularity of the function $z e^{-z}$ is the essential singularity at ∞ .

(b) The function

$$\frac{z^5}{(1-z)^2} = \frac{z^3}{\left(1 - \frac{1}{z}\right)^2}$$

has a double pole at $z = 1$ and a triple pole at ∞ .

(c) The function

$$\cot z - \frac{1}{z}$$

has simple poles at $z = p\pi$, $p \in \mathbb{Z} \setminus \{0\}$. Since $p\pi \rightarrow \infty$ for $p \rightarrow \pm\infty$, we see that ∞ is an essential (non-isolated) singularity.

The singularity at $z = 0$ requires a closer investigation:

$$\begin{aligned} \cot z - \frac{1}{z} &= \frac{\cos z}{\sin z} - \frac{1}{z} = \frac{z \cdot \cos z - \sin z}{z \cdot \sin z} = \frac{z \left\{ 1 - \frac{1}{2} z^2 + o(z^2) \right\} - \left\{ z - \frac{1}{6} z^3 + o(z^3) \right\}}{z^2 (1 + o(z))} \\ &= \frac{-\frac{z^3}{6} + o(z^3)}{z^2 (1 + o(z))} = -\frac{z}{6} + o(z), \end{aligned}$$

and we conclude that the singularity at $z = 0$ is removable.

Example 6.8 Indicate the type of the singular points in $\mathbb{C} \cup \{\infty\}$ of

$$(a) \frac{1}{e^z - 1} - \frac{1}{z}, \quad (b) \frac{e^z}{z(1 - e^{-z})}.$$

(a) The function

$$\frac{1}{e^z - 1} - \frac{1}{z}$$

has the simple poles for $z = 2p\pi i$, $p \in \mathbb{Z} \setminus \{0\}$. We see that ∞ is a (non-isolated) essential singularity.

The singularity at $z = 0$ requires a closer investigation. It follows by a series expansion that

$$\begin{aligned} \frac{1}{e^z - 1} - \frac{1}{z} &= \frac{z - e^z + 1}{z(e^z - 1)} = \frac{1 + z - \{1 + z + \frac{1}{2}z^2 + o(z^2)\}}{z\{1 + z + o(z) - 1\}} = \frac{-\frac{1}{2}z^2 + o(z^2)}{z^2 + o(z^2)} \\ &= -\frac{1}{2} \cdot \frac{1 + o(1)}{1 + o(1)}, \end{aligned}$$

and we conclude that the singularity at $z = 0$ is removable.



STUDY AT A TOP RANKED INTERNATIONAL BUSINESS SCHOOL

Reach your full potential at the Stockholm School of Economics, in one of the most innovative cities in the world. The School is ranked by the Financial Times as the number one business school in the Nordic and Baltic countries.

Visit us at www.hhs.se





(b) We have a double pole at $z = 0$, which e.g. can be seen by a Taylor expansion of the denominator.

We have simple poles for $z = 2p\pi i$, $p \in \mathbb{Z} \setminus \{0\}$.

The singularity at ∞ is not isolated, though the limit of a sequence of poles, hence ∞ is an essential (non-isolated) singularity.

Example 6.9 Indicate the type of the singular points in $\mathbb{C} \cup \{\infty\}$ of

$$(a) \frac{1 - e^z}{1 + e^z}, \quad (b) z \exp \frac{1}{z}.$$

(a) The function

$$\frac{1 - e^z}{1 + e^z} = \frac{2}{1 + e^z} - 1$$

has simple poles at $z = i(2p + 1)\pi$, $p \in \mathbb{Z}$, and a non-isolated essential singularity at ∞ .

(b) It follows from

$$z \exp \frac{1}{z} = \sum_{n=0}^{+\infty} \frac{1}{n!} \frac{1}{z^{n-1}},$$

that the singularity at $z = 0$ is essential.

It follows from

$$\exp \frac{1}{z} \rightarrow 1 \quad \text{for } z \rightarrow \infty,$$

that ∞ is a simple pole of $z \cdot \exp \frac{1}{z}$.

Example 6.10 Find all zeros and poles in $\mathbb{C} \cup \{\infty\}$ for

$$(a) \frac{z^2 - 1}{z^1}, \quad (b) \frac{z - 1}{z^3 + 1}.$$

(a) The simple zeros are 1 and -1 , and the simple poles are i and $-i$.

(b) The zeros are 1 (simple) and ∞ (double), and the three simple poles are

$$-1, \quad \frac{1}{2} + i \frac{\sqrt{3}}{2}, \quad \frac{1}{2} - i \frac{\sqrt{3}}{2}.$$

Example 6.11 Find all zeros and poles in $\mathbb{C} \cup \{\infty\}$ of

$$(a) \frac{(z-1)^2(z+2)^3}{z}, \quad (b) \frac{1}{(z-1)^3}.$$

(a) The zeros are

$$1, \quad 1, \quad -2, \quad -2, \quad -2,$$

and the poles are

$$0, \quad \infty, \quad \infty, \quad \infty, \quad \infty.$$

Here, 1 is a double zero, and -2 is a triple zero. Furthermore, 0 is a simple pole, and ∞ is a fourfold pole.

(b) It follows by inspection that ∞ is a triple zero, and that 1 is a triple pole.

Example 6.12 Given the function

$$f(z) = z^3 \cos\left(\frac{1}{z}\right).$$

1) Find in the domain $|z| > 0$ the Laurent series

$$\sum_{n=1}^{+\infty} \frac{b_n}{z^n} + \sum_{n=0}^{+\infty} a_n z^n$$

of the function f .

Indicate the coefficients a_n and b_n .

2) Indicate the isolated singularities of f in $\overline{\mathbb{C}} = \mathbb{C} \cup \{\infty\}$ and their type.

3) Find the value of the integral

$$\oint_{|z|=1} f(z) dz,$$

and the residuum of f at ∞ .

1) We get by insertion into the series of $\cos w$,

$$f(z) = z^3 \cos\left(\frac{1}{z}\right) = z^3 \sum_{n=0}^{+\infty} \frac{(-1)^n}{(2n)!} \left(\frac{1}{z}\right)^{2n} = z^3 - \frac{1}{2} z + \sum_{n=0}^{+\infty} \frac{(-1)^n}{(2n+4)!} \frac{1}{z^{2n+1}} \quad \text{for } |z| > 0.$$

It follows that

$$a_1 = -\frac{1}{2}, \quad a_3 = 1, \quad a_n = 0 \text{ for } n \in \mathbb{N}_0 \setminus \{1, 3\},$$

and

$$b_{2n} = 0 \text{ for } n \in \mathbb{N}_0, \quad b_{2n+1} = \frac{(-1)^n}{(2n+4)!} \text{ for } n \in \mathbb{N}_0.$$

2) The isolated singularities in $\overline{\mathbb{C}} = \mathbb{C} \cup \{\infty\}$ are an essential singularity at 0, and because $\cos\left(\frac{1}{z}\right) = \cos 0 = 1$ for $z \rightarrow \infty$, a pole of order 3 at ∞ .

3) Then by Cauchy's residue theorem,

$$\oint_{|z|=1} f(z) dz = 2\pi i \operatorname{res}(f; 0) = 2\pi i \cdot a_{-1} = \frac{2\pi i}{4!} = \frac{\pi i}{12} = -2\pi i \operatorname{res}(f; \infty),$$

so

$$\operatorname{res}(f; \infty) = -\operatorname{res}(f; 0) = -\frac{1}{4!} = -\frac{1}{24}.$$



#1
in eco-friendly
attitude

**STUDY AT
LINKÖPING UNIVERSITY, SWEDEN**
RANKED AMONG TOP 50 UNIVERSITIES UNDER 50

Interested in Strategy and Management in International Organisations? Kick-start your career with a master's degree from Linköping University, Sweden.

→ **Click here!**

 **Linköping University**

