

Complex Functions Examples c-3

Elementary Analytic Functions and Harmonic Functions

Leif Mejlbro



Download free books at

bookboon.com

Leif Mejlbro

Complex Functions Examples c-3

Elementary Analytic Functions and Harmonic
Functions

Complex Functions Examples c-3 – Elementary Analytic Functions and
Harmonic Functions

© 2008 Leif Mejlbro & Ventus Publishing ApS

ISBN 978-87-7681-387-1

Contents

	Introduction	5
1.	Some necessary theoretical results	6
2.	Polynomials	12
3.	Fractional functions	13
4.	The exponential function and the logarithm function	30
5.	Trigonometric and hyperbolic functions	46
6.	Harmonic functions	62

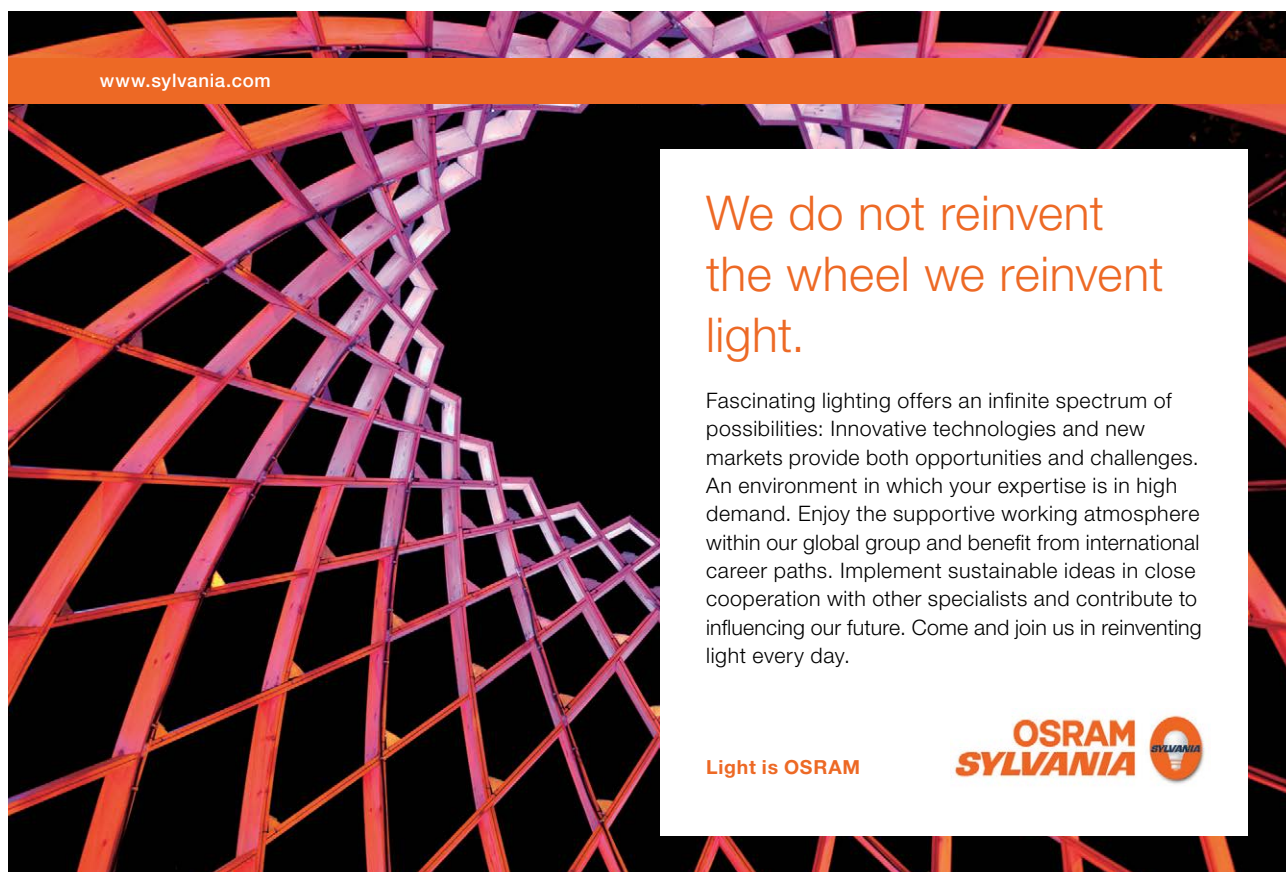

www.sylvania.com

**We do not reinvent
the wheel we reinvent
light.**

Fascinating lighting offers an infinite spectrum of possibilities: Innovative technologies and new markets provide both opportunities and challenges. An environment in which your expertise is in high demand. Enjoy the supportive working atmosphere within our global group and benefit from international career paths. Implement sustainable ideas in close cooperation with other specialists and contribute to influencing our future. Come and join us in reinventing light every day.

Light is OSRAM

**OSRAM
SYLVANIA** 



Introduction

This is the third book containing examples from the *Theory of Complex Functions*. The first topic will be examples of elementary analytic functions, like polynomials, fractional functions, exponential functions and the trigonometric and the hyperbolic functions. Then follow some examples of *harmonic functions*.

Even if I have tried to be careful about this text, it is impossible to avoid errors, in particular in the first edition. It is my hope that the reader will show some understanding of my situation.

Leif Mejlbro
4th June 2008

1 Some necessary theoretical results

We start with

Theorem 1.1 THE FUNDAMENTAL THEOREM OF ALGEBRA. *Every polynomial $P(z)$ of degree $n \geq 1$ has at least one complex root.*

This theorem immediately implies the following theorem:

Theorem 1.2 *If all roots of a polynomial are counted by multiplicity, then every polynomial $P(z)$ of degree n has exactly n complex roots.*

Concerning the decomposition of fractional functions we have the following important special case:

Theorem 1.3 *If the polynomial of the denominator (of degree m)*

$$Q(z) = (z - a_1) \cdots (z - a_m)$$

has only simple roots, i.e. all a_j , $j = 1, \dots, m$ are mutually different, and the polynomial of the numerator $P(z)$ has a degree which is smaller than m , then

$$\frac{P(z)}{Q(z)} = \sum_{j=1}^m \frac{P(a_j)}{Q'(a_j)} \cdot \frac{1}{z - a_j}, \quad z \in \mathbb{C} \setminus \{a_1, \dots, a_m\}.$$



Discover the truth at www.deloitte.ca/careers

Deloitte.

© Deloitte & Touche LLP and affiliated entities.



We should here also mention that the *complex exponential function* is defined by

$$\exp z = e^z := e^x \cos y + i e^x \sin y \quad \text{for } z = x + iy \in \mathbb{C}.$$

From this definition we derive the *complex trigonometric and hyperbolic functions* by

$$\begin{aligned} \sin z &:= \frac{1}{2i} \{e^{iz} - e^{-iz}\}, & \cos z &:= \frac{1}{2} \{e^{iz} + e^{-iz}\}, \\ \sinh z &:= \frac{1}{2} \{e^z - e^{-z}\}, & \cosh z &:= \frac{1}{2} \{e^z + e^{-z}\}, \end{aligned}$$

from which we furthermore derive

$$\begin{aligned} \tan z &:= \frac{\sin z}{\cos z}, & \cot z &:= \frac{\cos z}{\sin z}, \\ \tanh z &:= \frac{\sinh z}{\cosh z}, & \coth z &:= \frac{\cosh z}{\sinh z}, \end{aligned}$$

in the sets where these functions are defined, i.e. outside the zeros of the denominator.

We see that these functions all agree with the well-known ones from the real analysis, when $z = x \in \mathbb{R}$ is real. Furthermore, we have the derivatives

$$\frac{d}{dz} e^z = e^z,$$

$$\frac{d}{dz} \sin z = \cos z, \quad \frac{d}{dz} \cos z = -\sin z,$$

$$\frac{d}{dz} \sinh z = \cosh z, \quad \frac{d}{dz} \cosh z = \sinh z,$$

$$\frac{d}{dz} \tan z = \frac{1}{\cos^2 z}, \quad \frac{d}{dz} \cot z = -\frac{1}{\sin^2 z},$$

$$\frac{d}{dz} \tanh z = \frac{1}{\cosh^2 z}, \quad \frac{d}{dz} \coth z = -\frac{1}{\sinh^2 z},$$

where these also are in agreement with the known real expressions, when $z = x \in \mathbb{R}$ or real.

The fundamental relations also hold in the complex description,

$$\cos^2 z + \sin^2 z = 1, \quad \cosh^2 z - \sinh^2 z = 1, \quad \text{for } z \in \mathbb{C},$$

as well as the well-known rules of addition from the real are extended by just writing z instead of x :

$$\sin(z+w) = \sin z \cdot \cos w + \cos z \cdot \sin w,$$

$$\cos(z+w) = \cos z \cdot \cos w - \sin z \cdot \sin w,$$

$$\sinh(z+w) = \sinh z \cdot \cosh w + \cosh z \cdot \sinh w$$

$$\cosh(z+w) = \cosh z \cdot \cosh w + \sinh z \cdot \sinh w.$$

Furthermore, we have the *transformation formulæ*,

$$\begin{aligned}\sin(iz) &= i \cdot \sinh z, & \sinh(iz) &= i \cdot \sin z, \\ \cos(iz) &= \cosh z, & \cosh(iz) &= \cos z \\ \tan(iz) &= i \cdot \tanh z, & \tanh(iz) &= i \cdot \tan z \\ \cot(iz) &= -i \cdot \coth z, & \coth(iz) &= -i \cdot \cot z,\end{aligned}$$

We write as usual $z = x + it \in \mathbb{C}$. Then it follows easily from the above that,

$$\begin{aligned}\sin z &= \sin x \cdot \cosh y + i \cos x \cdot \sinh y, \\ \cos z &= \cos x \cdot \cosh y - i \sin x \cdot \sinh y, \\ \sinh z &= \sinh x \cdot \cos y + i \cosh x \cdot \sin y, \\ \cosh z &= \cosh x \cdot \cos y + i \sinh x \cdot \sin y.\end{aligned}$$

We now mention a couple of results concerning *harmonic functions*.

Definition 1.1 Assume that $\Omega \subseteq \mathbb{R}^2$ is an open domain in the real plane. A function $u \in C^2(\Omega)$ in the two real variables x and y is said to be harmonic in Ω , if it satisfies the equation

$$\Delta u := \frac{\partial^2 u}{\partial x^2} + \frac{\partial^2 u}{\partial y^2} = 0 \quad \text{for every } (x, y) \in \Omega.$$

The importance of the harmonic functions stems from the fact that the equation $\Delta = 0$ occurs frequently in the physical and technical applications. The connection with the Theory of Complex Functions is given by the following theorem.

Theorem 1.4 Assume that $f(z) = u(x, y) + i v(x, y)$ is analytic in an open domain $\Omega \subseteq \mathbb{C}$. If we also consider Ω as a subset of the real plane \mathbb{R}^2 , then both the real part $u(x, y)$ and the imaginary part $v(x, y)$ of the analytic function $f(z)$ are harmonic in Ω .

Assume that both $u(x, y)$ and $v(x, y)$ are harmonic functions in the same domain $\Omega \subseteq \mathbb{R}^2$. If the pair (u, v) furthermore fulfils *Cauchy-Riemann's equations*, we call v an *harmonic conjugated* function of u . It follows immediately that if (u, v) is a harmonic conjugated pair (notice the order of the functions), then $(-v, u)$ is also an harmonic conjugated pair.

Thus, harmonic conjugating is not a symmetric relation. The importance of an harmonic conjugated pair (u, v) lies in the fact that under some very mild assumption the level curves

$$u(x, y) = c_1, \quad v(x, y) = c_2,$$

are orthogonal to each other. This follows implicitly from

Theorem 1.5 Assume that (u, v) is an harmonic conjugated pair. Then $f(z) = u(x, y) + i v(x, y)$ is an analytic function in the same domain.

We now see that the missing condition for orthogonality above is that $f'(z) \neq 0$ at the point $z = x + iy \sim (x, y) \in \mathbb{R}^2$ under consideration. At the same time this shows that it is often easier to formulate a problem of harmonic functions by using analytic functions instead of the condition $\Delta u = 0$. Thus it is important to be able to find an harmonic conjugated of a given harmonic function. We have the following result:

Theorem 1.6 *Assume that $u(x, y)$ is harmonic in a simply connected open domain $\Omega \subseteq \mathbb{R}^2$ (i.e. a domain without “holes”). Then all possible harmonic conjugated functions of u are given by the line integral,*

$$v(x, y) = \int_{z_0}^z \left\{ -\frac{\partial u}{\partial y} dx + \frac{\partial u}{\partial x} dy \right\} + C, \quad \text{where } C \in \mathbb{R} \text{ is arbitrary.}$$

Here we integrate along any simple curve in Ω from the point z_0 to z , thus by one's own choice.

Since the harmonic functions are closely connected with the analytic functions, we may also expect a mean value theorem. We start with

Theorem 1.7 *The MAXIMUM (MINIMUM) PRINCIPLE FOR HARMONIC FUNCTIONS. Assume that $u(x, y)$ is harmonic and not a constant on an open domain Ω . Then $u(x, y)$ has neither a maximum nor a minimum in Ω .*

SIMPLY CLEVER

ŠKODA



We will turn your CV into
an opportunity of a lifetime

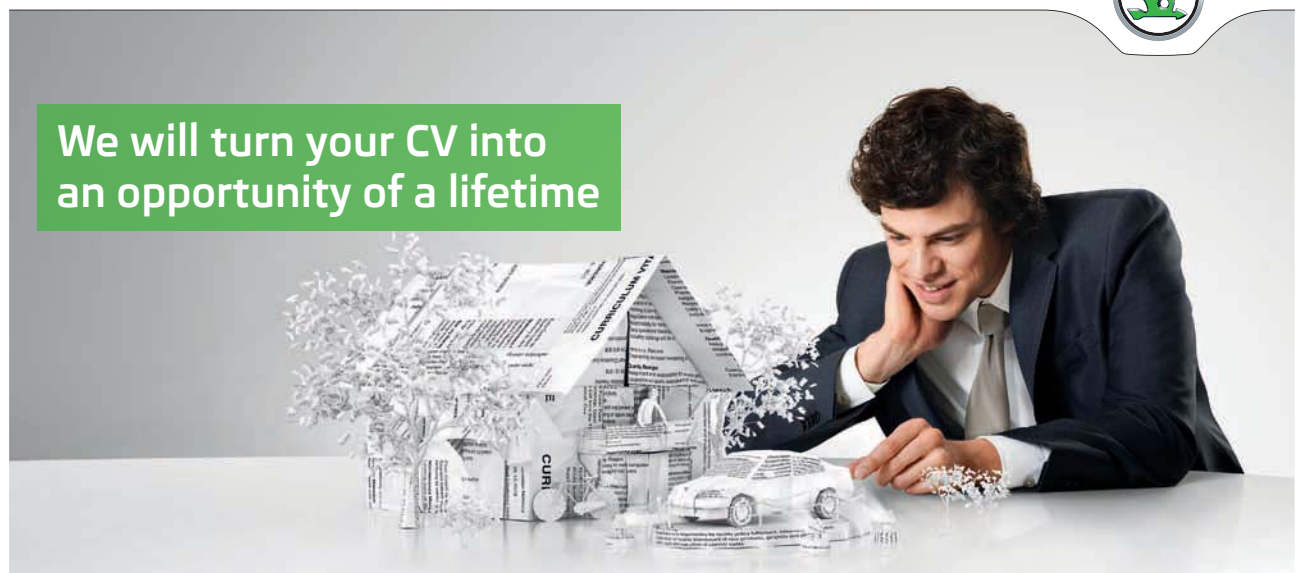

Do you like cars? Would you like to be a part of a successful brand?
We will appreciate and reward both your enthusiasm and talent.
Send us your CV. You will be surprised where it can take you.

Send us your CV on
www.employerforlife.com



Click on the ad to read more

Assume that $u(x, y)$ is harmonic and not a constant, and that $u(x, y)$ has a continuous extension to all of the boundary of a *bounded* domain Ω . Then it follows by one of the main theorems from the real analysis that the maximum and the minimum (which do exist) necessarily must be attained at a boundary point, i.e. in $\partial\Omega$.

Theorem 1.8 THE MEAN VALUE THEOREM FOR HARMONIC FUNCTIONS. *The value of an harmonic function $u(x, y)$ in an open domain Ω in a point $(x_0, y_0) \sim z_0 \in \Omega$ is equal to the mean value of the function over any circle of centrum z_0 and radius $r > 0$, provided that the closed disc $B[z_0, r] \subset \Omega$ is contained in Ω . We have explicitly for any such radius $r > 0$ that*

$$u(x_0, y_0) = u(z_0) = \frac{1}{2\pi} \int_0^{2\pi} u(z_0 + r e^{i\theta}) d\theta,$$

where we as usual freely changes between the notations $z_0 = x_0 + i y_0$ and (x_0, y_0) .

In 1820, Poisson derived a solution formula for the boundary value problem for the harmonic equation on a disc:

Theorem 1.9 POISSON'S INTEGRAL FORMULA. *Assume that $f(z) = u + iv$ is analytic in an open domain Ω , which contains the closed disc $B[0, R]$, and let $z_0 = x_0 + i y_0 = r e^{i\theta}$, $0 \leq r < R$ be any fixed point in the interior of this disc. Then*

$$u(z_0) = \frac{1}{2\pi} \int_0^{2\pi} \frac{R^2 - r^2}{R^2 + r^2 - 2Rr \cos(\theta - t)} u(R e^{it}) dt,$$

and analogously,

$$v(z_0) = \frac{1}{2\pi} \int_0^{2\pi} \frac{R^2 - r^2}{R^2 + r^2 - 2Rr \cos(\theta - t)} v(R e^{it}) dt.$$

Thus, $u(x, y)$ and $v(x, y)$ can be reconstructed from their values on the circle, which is given by the parametric description $R e^{it}$ $t \in [0, 2\pi]$.

If $u(x, y)$ is harmonic in Ω , then all harmonic conjugated of $u(x, y)$ are given by

$$v(z_0) = \frac{1}{2\pi} \int_0^{2\pi} \frac{2Rr \cdot \sin(\theta - t)}{R^2 + r^2 - 2Rr \cdot \cos(\theta - t)} u(R e^{it}) dt + v(0),$$

and we get

$$f(z_0) = \frac{1}{2\pi} \int_0^{2\pi} \frac{z + z_0}{z - z_0} u(z) dt + i v(0), \quad \text{where } z = R e^{it}, \quad t \in [0, 2\pi].$$

This formal result seems confused, so choose $\Omega = B(0, 1)$ as the open unit disc and assume that the boundary values function $h(z)$ is continuous on the boundary $|z| = 1$. Then it follows by a Fourier series expansion, that we have on the boundary,

$$h(e^{it}) \sim \frac{1}{2} a_0 + \sum_{n=1}^{+\infty} \{a_n \cos nt + b_n \sin nt\},$$

where

$$a_n = \frac{1}{\pi} \int_0^{2\pi} h(e^{it}) \cos nt dt, \quad \text{and} \quad b_n = \frac{1}{\pi} \int_0^{2\pi} h(e^{it}) \sin nt dt.$$

Then we obtain the following simple result,

Theorem 1.10 Assume that $h(z)$ is continuous on $|z| = 1$ and that $h(z)$ has the Fourier series expansion

$$h(e^{it}) \sim \frac{1}{2}a_0 + \sum_{n=1}^{+\infty} \{a_n \cos nt + b_n \sin nt\}.$$

Then the unique solution of the boundary value problem

$$\begin{cases} \Delta u = 0 & \text{for } x^2 + y^2 < 1, \\ u(x, y) = h(x, y) & \text{for } x^2 + y^2 = 1, \end{cases}$$

is given by

$$u(re^{i\theta}) = \frac{1}{2}a_0 + \sum_{n=1}^{+\infty} r^n \{a_n \cos n\theta + b_n \sin n\theta\}, \quad 0 \leq r < 1,$$

so we just add the factor r^n to the n -th term in the Fourier expansion of the boundary value function in order to obtain the solution.

I joined MITAS because
I wanted **real responsibility**

The Graduate Programme
for Engineers and Geoscientists
www.discovermitas.com



Real work
International opportunities
Three work placements



Month 16
I was a construction
supervisor in
the North Sea
advising and
helping foremen
solve problems





2 Polynomials

Example 2.1 Suppose that all zeros of a polynomial $P_n(z)$ of degree $n > 1$ lie in the open left half plane. Prove that then all zeros of $P'_n(z)$ are also lying in the open left half plane.

HINT: Apply the factor expansion of $P_n(z)$ and then consider the logarithmic derivative $\frac{P'_n(z)}{P_n(z)}$. Prove that we obtain a conflict if we assume that $P'_n(z_0) = 0$ for some z_0 where $\operatorname{Re}(z_0) \geq 0$. We call polynomials of this type Hurwitz polynomials.

Assume that

$$P_n(z) = A(z - z_1)(z - z_2) \cdots (z - z_n),$$

where $\operatorname{Re}(z_j) < 0$ for $j = 1, 2, \dots, n$, and where we allow some of the z_j to be identical. Obviously, we may assume that $A = 1$. Then

$$P'_n(z) = (z - z_2) \cdots (z - z_n) + (z - z_1) \cdots (z - z_{n-1}) + \cdots + (z - z_1) \cdots (z - z_{n-1}),$$

and thus

$$\frac{P'_n(z)}{P_n(z)} = \frac{1}{z - z_1} + \frac{1}{z - z_2} + \cdots + \frac{1}{z - z_n}.$$

If we put $z_j = x_j + iy_j$, $j = 1, \dots, n$, and analogously $z = x + iy$, then

$$\operatorname{Re} \left\{ \frac{P'_n(z)}{P_n(z)} \right\} = \frac{x - x_1}{(x - x_1)^2 + (y - y_1)^2} + \cdots + \frac{x - x_n}{(x - x_n)^2 + (y - y_n)^2}.$$

According to the assumption, $-x_j > 0$ for $j = 1, \dots, n$. Hence it follows that

$$\operatorname{Re} \left\{ \frac{P'_n(z)}{P_n(z)} \right\} > 0, \quad \text{if } x = \operatorname{Re}(z) \geq 0,$$

thus $P'_n(z) \neq 0$ for $x = \operatorname{Re}(z) \geq 0$. The claim is proved.

Remark 2.1 By elaborating further on the argument above it is possible to prove that the zeros of $P'_n(z)$ lie in the convex hull of the zeros of $P_n(z)$. \diamond

3 Fractional functions

Example 3.1 A fixpoint of the fractional function

$$f(z) = \frac{az + b}{cz + d}, \quad \text{where } \begin{vmatrix} a & b \\ c & d \end{vmatrix} \neq 0, \quad a, b, c, d \in \mathbb{C}$$

is a point $z \in \mathbb{C}$, for which $f(z) = z$.

If $c = 0$, we consider ∞ as a fixpoint.

Prove that if $f(z)$ is not the identity function, then there are at most two fixpoints for $f(z)$.

Let $c \neq 0$ and assume that z is a fixpoint,

$$z = \frac{az + b}{cz + d}.$$

This equation is equivalent to the follows equation of second degree,

$$cz^2 + (d - a)z + b = 0.$$

According to the *Fundamental Theorem of Algebra* this equation has two roots, so the function has two fixpoints.

If the roots are identical, i.e. if $(d - a)^2 = 4bc$, one usually says that the equation has only one fixpoint.

If $c = 0$ and $T \neq I$, then ∞ is a fixpoint. If $z \in \mathbb{C}$ is another fixpoint, then

$$z = \frac{a}{d}z + \frac{b}{d},$$

because the condition

$$\begin{vmatrix} a & b \\ c & d \end{vmatrix}$$

together with $c = 0$ assures that $d \neq 0$. Hence it follows that if $a \neq d$, then we have precisely two fixpoints, where ∞ is one of them. If $a = d$ and $b = 0$, then $T = I$, and if $a = d$ and $b \neq 0$, then ∞ is the only fixpoint.

Example 3.2 Decompose inside \mathbb{C} :

$$(a) \frac{10}{(z+2)(z^2+1)}, \quad (b) \frac{z^2-1}{(z+2)(z+3)}, \quad (c) \frac{24}{z^2(z-1)(z+2)}.$$

(a) Here,

$$\begin{aligned} \frac{10}{(z+2)(z^2+1)} &= \frac{10}{(z+2)(z-i)(z+i)} = \frac{1}{z+2} \cdot \frac{10}{5} + \frac{1}{z-i} \cdot \frac{10}{(i+2)2i} + \frac{1}{z+i} \cdot \frac{10}{(2-i)(-2i)} \\ &= \frac{2}{z+2} - \frac{1+2i}{z-i} - \frac{1-2i}{z+i}. \end{aligned}$$

(b) First perform a division

$$\begin{aligned}\frac{z^2 - 1}{(z + 2)(z + 3)} &= 1 + \frac{z^1 - 1 - (z + 2)(z + 3)}{(z + 2)(z + 3)} = 1 + \frac{1}{z + 2} \cdot \frac{4 - 1}{1} + \frac{1}{z + 3} \cdot \frac{9 - 1}{(-1)} \\ &= 1 + \frac{3}{z + 2} - \frac{8}{z + 3}.\end{aligned}$$

(c) Here we shall be aware of the factor z^2 in the denominator:

$$\begin{aligned}\frac{24}{z^2(z - 1)(z + 2)} &= \frac{1}{z^2} \cdot \frac{24}{-2} + \frac{A}{z} + \frac{1}{z - 1} \cdot \frac{24}{1 \cdot 3} + \frac{1}{z + 2} \cdot \frac{24}{4(-3)} \\ &= -\frac{12}{z^2} + \frac{A}{z} + \frac{8}{z - 1} - \frac{2}{z + 2}.\end{aligned}$$

Now

$$\begin{aligned}\frac{24}{z^2(z - 1)(z + 2)} + \frac{12}{z^2} &= \frac{12}{z^2(z - 1)(z + 2)} \{2 + z^2 + z - 2\} \\ &= \frac{12(z + 1)}{z(z - 1)(z + 2)} = \frac{A}{z} + \frac{8}{z - 1} - \frac{2}{z + 2},\end{aligned}$$

by a rearrangement and a reduction of the above. We therefore conclude by the standard method that

$$A = \frac{12(0 + 1)}{-1 \cdot 2} = -6,$$

hence by insertion,

$$\frac{24}{z^2(z - 1)(z + 2)} = -\frac{12}{z^2} - \frac{6}{z} + \frac{8}{z - 1} - \frac{2}{z + 2}.$$

ALTERNATIVELY one may find A by a formula, which is derived in a later book, so we only mention the easy computations. Since $n = 2$ and $j = 1$, we get

$$\begin{aligned}A &= \frac{1}{(2 - 1)!} \lim_{z \rightarrow 0} \frac{d^{2-1}}{dz^{2-1}} \left\{ \frac{24}{(z - 1)(z + 2)} \right\} = \lim_{z \rightarrow 0} \frac{d}{dz} \left\{ \frac{8}{z - 1} - \frac{8}{z + 2} \right\} \\ &= \lim_{z \rightarrow 0} \left\{ -\frac{8}{(z - 1)^2} + \frac{8}{(z + 2)^2} \right\} = -8 + \frac{8}{4} = -6,\end{aligned}$$

and then as before by insertion,

$$\frac{24}{z^2(z - 1)(z + 2)} = -\frac{12}{z^2} - \frac{6}{z} + \frac{8}{z - 1} - \frac{2}{z + 2}.$$

Example 3.3 Decompose inside \mathbb{C} :

$$(a) \frac{z}{z^4 + 1}, \quad (b) \frac{z^3 + 5}{(z^4 - 1)(z + 1)}, \quad (c) \frac{z^3 - 3z + 1}{(z - i)^2}.$$

(a) The equation $z^4 = -1$ has the solutions

$$z = \frac{1}{\sqrt{2}}(\pm 1 \pm i),$$

all four possible combinations of the signs. It follows that every zero z_j is of order 1, hence the coefficient of $\frac{1}{z - z_j}$ is given by

$$\lim_{z \rightarrow z_j} z \cdot \frac{z - z_j}{z^4 + 1} = z_j \lim_{z \rightarrow z_j} \frac{1}{\frac{(z^4 + 1) - (z_j^4 + 1)}{z - z_j}} = \frac{z_j}{4z_j^3} = \frac{z_j^2}{4z_j^4} = -\frac{z_j^2}{4}.$$

Then

$$\frac{z}{z^4 + 1} = \frac{i}{4} \cdot \frac{1}{z - \frac{-1+i}{\sqrt{2}}} + \frac{i}{4} \cdot \frac{1}{z - \frac{1-i}{\sqrt{2}}} - \frac{i}{4} \cdot \frac{1}{z - \frac{1+i}{\sqrt{2}}} - \frac{i}{4} \cdot \frac{1}{z - \frac{-1-i}{\sqrt{2}}}.$$

IE business school

#1 EUROPEAN BUSINESS SCHOOL
FINANCIAL TIMES 2013

#gobeyond

MASTER IN MANAGEMENT

Because achieving your dreams is your greatest challenge. IE Business School's Master in Management taught in English, Spanish or bilingually, trains young high performance professionals at the beginning of their career through an innovative and stimulating program that will help them reach their full potential.

- Choose your area of specialization.
- Customize your master through the different options offered.
- Global Immersion Weeks in locations such as London, Silicon Valley or Shanghai.

Because you change, we change with you.

www.ie.edu/master-management | mim.admissions@ie.edu | Facebook | Twitter | LinkedIn | YouTube | Instagram

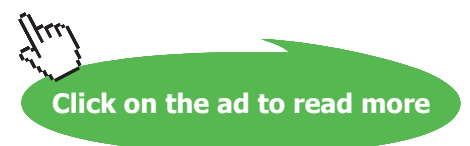

(b) Since

$$(z^4 - 1)(z + 1) = (z^2 - 1)(z^2 + 1)(z + 1) = (z + 1)^2(z - 1)(z - i)(z + i),$$

we get by the standard method,

$$\begin{aligned} \frac{z^3 + 5}{(z^4 - 1)(z + 1)} &= \frac{z^3 + 5}{(z + 1)^2(z - 1)(z - i)(z + i)} \\ &= \frac{1}{(z + 1)^2} \cdot \frac{-1 + 5}{(-2) \cdot 2} + \frac{A}{z + 1} + \frac{1}{z - 1} \cdot \frac{1 + 5}{2^2 \cdot 2} \\ &\quad + \frac{1}{z - i} \cdot \frac{5 - i}{(i + 1)^2(i - 1) \cdot 2i} + \frac{1}{z + i} \cdot \frac{5 + i}{(1 - i)^2(-i - 1)(-2i)} \\ &= -\frac{1}{(z + 1)^2} + \frac{A}{z + 1} + \frac{3}{4} \cdot \frac{1}{z - 1} + \frac{5 - i}{4(1 - i)} \cdot \frac{1}{z - i} + \frac{5 + i}{4(1 + i)} \cdot \frac{1}{z + i}. \end{aligned}$$

From

$$\begin{aligned} \frac{z^3 + 5}{(z^4 - 1)(z + 1)} + \frac{1}{(z + 1)^2} &= \frac{1}{(z^4 - 1)(z + 1)} \{z^3 + 5 + z^3 - z^2 + z - 1\} \\ &= \frac{2z^2 - 3z + 4}{z^4 - 1} = \frac{A}{z + 1} + \dots, \end{aligned}$$

follows by the standard method,

$$A = \frac{2 + 3 + 4}{-2 \cdot 2} = -\frac{9}{4},$$

hence by insertion and reduction,

$$\frac{z^3 + 5}{(z^4 - 1)(z + 1)} = -\frac{1}{(z + 1)^2} - \frac{9}{4} \frac{1}{z + 1} + \frac{3}{4} \frac{1}{z - 1} + \frac{3 + 2i}{4} \frac{1}{z - i} + \frac{3 - 2i}{4} \frac{1}{z + i}.$$

ALTERNATIVELY it follows that

$$\frac{z^3 + 5}{(z^4 - 1)(z + 1)} = \frac{z^3 + 5}{(z + 1)^2(z - 1)(z^2 + 1)}.$$

By the standard procedure we obtain the coefficient

$$\frac{-1 + 5}{-2 \cdot 2} = -1$$

of $\frac{1}{(z + 1)^2}$.

The remaining terms are then obtained by a decomposition of

$$\begin{aligned} \frac{z^3 + 5}{(z^4 - 1)(z + 1)} - \frac{-1}{(z + 1)^2} &= \frac{1}{(z^4 - 1)(z + 1)} \{z^3 + 5 + z^3 - z^2 + z - 1\} \\ &= \frac{2z^3 - z^2 + z + 4}{(z^4 - 1)(z + 1)} = \frac{2z^2 - 3z + 4}{z^4 - 1}. \end{aligned}$$

Every pole z_0 is simple and fulfils $z_0^4 = 1$, so the coefficient of $\frac{1}{z - z_0}$ becomes

$$\frac{2z_0^2 - 3z_0 + 4}{4z_0^3} = \frac{2z_0^3 - 3z_0^2 + 4z_0}{4z_0^4} = \frac{1}{4} \{2z_0^3 - 3z_0^2 + 4z_0\}.$$

Finally, by insertion of $z_0 = -1, 1, i$ and $-i$ we get

$$\frac{z^3 + 5}{(z^4 - 1)(z + 1)} = -\frac{1}{(z + 1)^2} - \frac{9}{4} \frac{1}{z + 1} + \frac{3}{4} \frac{1}{z - 1} + \frac{3 + 2i}{4} \frac{1}{z - i} + \frac{3 - 2i}{4} \frac{1}{z + i}.$$

ALTERNATIVELY we may exploit that since $z_0 \in \{1, i, -i\}$ is a *simple pole* (and in particular $z_0^4 = 1$), then the coefficient of $\frac{1}{z - z_0}$ is given in the decomposition by

$$\lim_{z \rightarrow z_0} \frac{z^3 + 5}{4z^3(z + 1) + (z^4 - 1)} = \frac{z_0^3 + 5}{4z_0^3(z_0 + 1)} = \frac{1}{4} \cdot \frac{z_0^4 + 5z_0}{z_0^4 \cdot (z_0 + 1)} = \frac{1}{4} \cdot \frac{5z_0 + 1}{z_0 + 1}.$$

If $z_0 = 1$, then we get the coefficient

$$\frac{1}{4} \cdot \frac{5 + 1}{1 + 1} = \frac{3}{4}.$$

If $z_0 = i$, then we get the coefficient

$$\frac{1}{4} \cdot \frac{1 + 5i}{1 + i} = \frac{1}{4} \cdot \frac{1 + 5i}{1 + i} \cdot \frac{1 - i}{1 - i} = \frac{1}{4} \cdot \frac{1 + 5 + i(5 - 1)}{1^2 + 1^2} = \frac{3 + 2i}{2}.$$

If $z_0 = -i$, then we get by complex conjugation that the coefficient is $\frac{3 - 2i}{2}$, because every coefficient of the fractional function is real.

By the standard method we see that the coefficient of $\frac{1}{(z + 1)^2}$ is

$$\lim_{z \rightarrow -1} (z + 1)^2 \cdot \frac{z^3 + 5}{(z^1 - 1)(z^2 + 1)(z + 1)} = \lim_{z \rightarrow -1} \frac{z^3 + 5}{(z - 1)(z^2 + 1)} = \frac{-1 + 5}{-2 \cdot 2} = -1.$$

Finally, the coefficient of $\frac{1}{z + 1}$ is also given by some residue formula

$$\begin{aligned} & \frac{1}{(2 - 1)!} \lim_{z \rightarrow -1} \frac{d^{2-1}}{dz^{2-1}} \left\{ \frac{(z + 1)^2 (z^3 + 5)}{(z^2 - 1)(z^2 + 1)(z + 1)} \right\} = \lim_{z \rightarrow -1} \frac{d}{dz} \left\{ \frac{z^3 + 5}{(z - 1)(z^2 + 1)} \right\} \\ &= \lim_{z \rightarrow -1} \left\{ \frac{3z^2}{(z - 1)(z^2 + 1)} - \frac{(z^3 + 5) \cdot 1}{(z - 1)^2 (z^2 + 1)} - \frac{(z^3 + 5) 2z}{(z - 1)(z^2 + 1)^2} \right\} \\ &= \frac{3(-1)^2}{(-2) \cdot 2} - \frac{-1 + 5}{4 \cdot 2} - \frac{(-1 + 5) \cdot (-2)}{(-2) \cdot 4} = -\frac{3}{4} - \frac{4}{8} - \frac{4}{4} \\ &= -\frac{3 + 2 + 4}{4} = -\frac{9}{4}, \end{aligned}$$

and we have as before,

$$\frac{z^3 + 5}{(z^4 - 1)(z + 1)} = -\frac{1}{(z + 1)^2} - \frac{9}{4} \frac{1}{z + 1} + \frac{3}{4} \frac{1}{z - 1} + \frac{3 + 2i}{4} \frac{1}{z - i} + \frac{3 - 2i}{4} \frac{1}{z + i}.$$

(c) Since the degree of the numerator is bigger than the degree of the denominator we must first perform a division. Since

$$(z - i)^2 = z^2 - 2iz - 1,$$

we get by the decomposition that

$$\frac{z^3 - 3z + 1}{(z - i)^2} = z + 2i + \frac{-6z + (1 + 2i)}{(z - i)^2} = z + 2i - \frac{6}{z - i} + \frac{1 - 4i}{(z - i)^2}.$$

ALTERNATIVELY,

$$\frac{z^3 - 3z + 1}{(z - i)^2} = z + 2i + \frac{A}{(z - i)^2} + \frac{B}{z - i},$$

where we in finding A and B may use the denominator $z^3 - 3z + 1$ instead of $-6z + (1 + 2i)$ (why?), by which the computations become smoother,

$$A \lim_{z \rightarrow i} \{z^3 - 3z + 1\} = i^3 - 3i + 1 = -i - 3i + 1 = 1 - 4i.$$

According to some residue formula where $n = 2$ and $j = 1$ we get

$$B = \lim_{z \rightarrow i} \frac{d}{dz} \{z^3 - 3z + 1\} = \lim_{z \rightarrow i} \{3z^2 - 3\} = -6,$$

and hence by insertion

$$\frac{z^3 - 3z + 1}{(z - i)^2} = z + 2i + \frac{1 - 4i}{(z - i)^2} - \frac{6}{z - i}.$$

Example 3.4 Decompose inside \mathbb{C} :

$$(a) \frac{z^4 + 1}{z(z^2 + 1)}, \quad (b) \frac{z^4 + 1}{z(z^2 - 1)}, \quad (c) \frac{z^4 - 1}{z^2 + 1}.$$

(a) By a direct computation,

$$\begin{aligned} \frac{z^4 + 1}{z(z^2 + 1)} &= \frac{z^4 + z^2 - z^2 + 1}{z(z^2 + 1)} = z + \frac{-z^2 + 1}{z(z - i)(z + i)} \\ &= z + \frac{1}{1} \cdot \frac{1}{z} + \frac{1 + 1}{i \cdot 2i} \cdot \frac{1}{z - i} + \frac{1 + 1}{-i(-2i)} \cdot \frac{1}{z + i} \\ &= z + \frac{1}{z} - \frac{1}{z - i} - \frac{1}{z + i}. \end{aligned}$$

(b) In this case we get analogously,

$$\frac{z^4 + 1}{z(z^2 - 1)} = \frac{z^4 - z^2 + z^2 + 1}{z(z^2 - 1)} = z + \frac{z^2 + 1}{z(z - 1)(z + 1)} = z - \frac{1}{z} + \frac{1}{z - 1} + \frac{1}{z + 1}.$$

(c) Here is

$$\frac{z^2 - 1}{z^2 + 1} = 1 + \frac{-2}{(z - i)(z + i)} = 1 + \frac{-2}{2i} \cdot \frac{1}{z - i} + \frac{-2}{-2i} \cdot \frac{1}{z + i} = 1 + \frac{i}{z - i} - \frac{i}{z + i}.$$

Example 3.5 Decompose inside \mathbb{C} :

$$(a) \frac{2z + 1}{z(z^2 + 1)}, \quad (b) \frac{z^3 + i}{z^2 - 3z + 2}, \quad (c) \frac{3z^3 + 2}{(z - 1)(z^2 + 9)}.$$

(a) By the standard procedure;

$$\begin{aligned} \frac{2z + 1}{z(z^2 + 1)} &= \frac{2z + 1}{z(z - i)(z + i)} = \frac{1}{z} + \frac{2i + 1}{i \cdot 2i} \cdot \frac{1}{z - i} + \frac{-2i + 1}{(-i)(-2i)} \cdot \frac{1}{z + i} \\ &= \frac{1}{z} - \frac{1 + 2i}{2(z - i)} - \frac{1 - 2i}{2(z + i)}. \end{aligned}$$



no.1
nine years
in a row

Syeden
Stockholm

STUDY AT A TOP RANKED INTERNATIONAL BUSINESS SCHOOL

Reach your full potential at the Stockholm School of Economics, in one of the most innovative cities in the world. The School is ranked by the Financial Times as the number one business school in the Nordic and Baltic countries.

Visit us at www.hhs.se







(b) The degree of the numerator is bigger than the degree of the dominator, so we first perform a division,

$$\begin{aligned}\frac{z^3 + i}{z^2 - 3z + 2} &= z + 3 + \frac{7z - 6 + i}{(z-1)(z-2)} = z + 3 + \frac{7-6+i}{1-2} \cdot \frac{1}{z-1} + \frac{14-6+i}{2-1} \cdot \frac{1}{z-2} \\ &= z + 3 - \frac{1+i}{z-1} + \frac{8+i}{z-2}.\end{aligned}$$

(c) Since we by the standard procedure always obtain the singular part (though not the additional polynomial) we can put $\pm 3i$ into $3z^3 + 2$ instead of into the remainder $3z^2 - 27z + 29$ from the division. Then

$$\begin{aligned}\frac{3z^3 + 2}{(z-1)(z^2+9)} &= 3 + \frac{3z^2 - 27z + 29}{(z-1)(z-3i)(z+3i)} \\ &= 3 + \frac{5}{10} \cdot \frac{1}{z-1} + \frac{2-81i}{(3i-1)6i} \cdot \frac{1}{z-3i} + \frac{2+81i}{(-3i-1)(-6i)} \cdot \frac{1}{z+3i} \\ &= 3 + \frac{1}{2} \frac{1}{z-1} + \frac{1}{6} \frac{(2-81i)(-3+i)}{(-3-i)(-3+i)} \frac{1}{z-3i} + \frac{1}{6} \frac{(2+81i)(-3-i)}{(-3+i)(-3+i)(-3-i)} \frac{1}{z+3i} \\ &= 3 + \frac{1}{2} \frac{1}{z-1} + \frac{1}{60} (-6+81+i\{243+2\}) \frac{1}{z-3i} + \frac{1}{60} (-6+81+i\{243+2\}) \frac{1}{z+3i} \\ &= 3 + \frac{1}{2} \frac{1}{z-1} + \frac{75+245i}{60} \frac{1}{z-3i} + \frac{75-245i}{60} \frac{1}{z+3i} \\ &= 3 + \frac{1}{2} \frac{1}{z-1} + \frac{15+49i}{12} \frac{1}{z-3i} + \frac{15-49i}{12} \frac{1}{z+3i}.\end{aligned}$$

Example 3.6 Decompose partly inside \mathbb{R} and partly inside \mathbb{C} :

$$(a) \frac{z^3}{(z-1)(z^4+1)}, \quad (b) \frac{(z^3-1)(z+2)}{(z^4-1)^2}, \quad (c) \frac{1}{(z^2-1)(z+2)}.$$

Since the real decomposition can be derived from the complex decomposition, and since a direct computation of the real decomposition is rather difficult, we shall here only give the complex variant.

(a) the zeros of the denominator are

$$1, \quad \frac{1}{\sqrt{2}}(2+i), \quad \frac{1}{\sqrt{2}}(1-i), \quad \frac{1}{\sqrt{2}}(-1+i), \quad \frac{1}{\sqrt{2}}(-1-i)$$

and they are all simple. Then the coefficient of $\frac{1}{z-1}$ is given by

$$a_0 = \lim_{z \rightarrow 1} \frac{z^3}{z^4+1} = \frac{1}{2},$$

and the coefficient of $\frac{1}{z-z_j}$, where $z_j^4 = -1$, is given by

$$a_j = \lim_{z \rightarrow z_j} \frac{(z-z_j)z^3}{(z-1)(z^4+1)} = \frac{z_j^3}{z_j-1} \cdot \frac{1}{\lim_{z \rightarrow z_j} \frac{z^4+1}{z-z_j}} = \frac{z_j^3}{z_j-1} \cdot \frac{1}{4z_j^3} = \frac{1}{4} \cdot \frac{1}{z_j-1}.$$

Hence,

1) if $z_1 = \frac{1+i}{\sqrt{2}}$, then

$$\begin{aligned} a_1 &= \frac{1}{4} \cdot \frac{1}{\frac{1+i}{\sqrt{2}} - 1} = \frac{\sqrt{2}}{4} \cdot \frac{1}{(1-\sqrt{2})+i} \cdot \frac{(1-\sqrt{2})-i}{(1-\sqrt{2})-i} \\ &= \frac{\sqrt{2}}{4} \cdot \frac{1-\sqrt{2}-i}{(1-\sqrt{2})^2+1} = \frac{\sqrt{2}}{4} \cdot \frac{1-\sqrt{2}-i}{1-2\sqrt{2}+2+1} \\ &= \frac{\sqrt{2}}{8} \cdot \frac{1-\sqrt{2}-i}{2-\sqrt{2}} = \frac{\sqrt{2}}{8} \cdot \frac{1-\sqrt{2}-i}{2-\sqrt{2}} \cdot \frac{2+\sqrt{2}}{2+\sqrt{2}} \\ &= \frac{\sqrt{2}}{8} \cdot \frac{1}{2} \{2-2\sqrt{2}+\sqrt{2}-2-i\sqrt{2}(1+\sqrt{2})\} \\ &= -\frac{1}{8} - i \frac{1+\sqrt{2}}{8}; \end{aligned}$$

2) if $z_2 = \frac{-1+i}{\sqrt{2}}$, then

$$\begin{aligned} a_2 &= \frac{1}{4} \cdot \frac{1}{\frac{-1+i}{\sqrt{2}} - 1} = \frac{\sqrt{2}}{4} \cdot \frac{1}{(-1-\sqrt{2})+i} \cdot \frac{(-1-\sqrt{2})-i}{(-1-\sqrt{2})-i} \\ &= \frac{\sqrt{2}}{4} \cdot \frac{-1-\sqrt{2}-i}{(1+\sqrt{2})^2+1} = \frac{\sqrt{2}}{4} \cdot \frac{-1-\sqrt{2}-i}{1+2\sqrt{2}+2+1} \\ &= \frac{\sqrt{2}}{8} \cdot \frac{-1-\sqrt{2}-i}{2+\sqrt{2}} = \frac{\sqrt{2}}{8} \cdot \frac{-1-\sqrt{2}-i}{2+\sqrt{2}} \cdot \frac{2+\sqrt{2}}{2+\sqrt{2}} \\ &= \frac{\sqrt{2}}{8} \cdot \frac{1}{2} \frac{-2-2\sqrt{2}-2i}{1+\sqrt{2}} \\ &= -\frac{1}{8} - i \frac{\sqrt{2}-1}{8}; \end{aligned}$$

3) if $z_3 = \frac{-1-i}{\sqrt{2}} = \bar{z}_2$, then

$$a_3 = \bar{a}_2 = -\frac{1}{8} + i \frac{\sqrt{2}-1}{8};$$

4) if $z_4 = \frac{1-i}{\sqrt{2}} = \bar{z}_1$, then

$$a_4 = \bar{a}_1 = -\frac{1}{8} + i \frac{\sqrt{2}+1}{8}.$$

Thus the complex decomposition is given by

$$\begin{aligned} \frac{z^3}{(z-1)(z^4+1)} &= \frac{1}{2} \frac{1}{z-1} - \frac{1+(\sqrt{2}+1)i}{8} \cdot \frac{1}{z-\frac{1+i}{\sqrt{2}}} - \frac{1+(\sqrt{2}-1)i}{8} \cdot \frac{1}{z-\frac{-1+i}{\sqrt{2}}} \\ &\quad - \frac{1-(\sqrt{2}+1)i}{8} \cdot \frac{1}{z-\frac{1-i}{\sqrt{2}}} - \frac{1-(\sqrt{2}-1)i}{8} \cdot \frac{1}{z-\frac{-1-i}{\sqrt{2}}}. \end{aligned}$$

REAL DECOMPOSITION. Since

$$\begin{aligned}\frac{a+ib}{z-(c+id)} + \frac{a-ib}{z-(c-id)} &= \frac{(a+ib)(z-(c-id)) + (a-ib)(z-(c+id))}{(z-c)^2 + d^2} \\ &= \frac{2az - 2ac - 2bd}{(z-c)^2 + d^2},\end{aligned}$$

we get

$$\begin{aligned}-\frac{1+(\sqrt{2}+1)i}{8} \cdot \frac{1}{z-\frac{1+i}{\sqrt{2}}} - \frac{1-(\sqrt{2}+1)i}{8} \cdot \frac{1}{z-\frac{1-i}{\sqrt{2}}} \\ = -\frac{1}{8} \cdot \frac{2z-2 \cdot \frac{1}{\sqrt{2}} - 2(\sqrt{2}+1) \frac{1}{\sqrt{2}}}{\left(z-\frac{1}{\sqrt{2}}\right)^2 + \frac{1}{2}} = -\frac{1}{8} \cdot \frac{2z-\sqrt{2}-\sqrt{2}(\sqrt{2}+1)}{z^2-\sqrt{2}z+1} \\ = -\frac{1}{8} \cdot \frac{2z-2-2\sqrt{2}}{z^2-\sqrt{2}z+1} = -\frac{1}{4} \cdot \frac{z-1-\sqrt{2}}{z^2-\sqrt{2}z+1},\end{aligned}$$

and analogously,

$$-\frac{1+(\sqrt{2}-1)i}{8} \cdot \frac{1}{z-\frac{-1+i}{\sqrt{2}}} - \frac{1+(\sqrt{2}-1)i}{8} \cdot \frac{1}{z-\frac{-1-i}{\sqrt{2}}} = -\frac{1}{4} \cdot \frac{z+\sqrt{2}-1}{z^2+\sqrt{2}z+1},$$

so we conclude that the real decomposition is

$$\frac{z^3}{(z-1)(z^4+1)} = \frac{1}{2} \cdot \frac{1}{z-1} - \frac{1}{4} \cdot \frac{z-1-\sqrt{2}}{z^2-\sqrt{2}z+1} - \frac{1}{4} \cdot \frac{z+\sqrt{2}-1}{z^2+\sqrt{2}z+1}.$$

- (b) This is the most difficult decomposition in this example. Notice that even if $z-1$ is a divisor in both the numerator and the denominator, it will be most convenient not to remove this factor. We first get

$$\frac{(z^3-1)(z+2)}{(z^4-1)^2} = \frac{z^4+2z^3-z-2}{(z^4-1)^2} = \frac{1}{z^4-1} + \frac{2z^3-z-1}{(z^4-1)^2}.$$

Then we use a small trick, by using that

$$\frac{1}{z^4-1} = \frac{1}{(z^2-1)(z^2+1)} = \frac{1}{2} \cdot \frac{1}{z^2-1} - \frac{1}{2} \cdot \frac{1}{z^2+1}.$$

Hence by a squaring,

$$\begin{aligned}\frac{1}{(z^4-1)^2} &= \frac{1}{4} \cdot \frac{1}{(z^2-1)^2} + \frac{1}{4} \cdot \frac{1}{(z^2+1)^2} - \frac{1}{2} \cdot \frac{1}{z^4-1} \\ &= \frac{1}{4} \left\{ \frac{1}{(z^2-1)^2} + \frac{1}{(z^2+1)^2} - \frac{1}{z^2-1} + \frac{1}{z^2+1} \right\},\end{aligned}$$

which by insertion gives

$$\begin{aligned}
 \frac{(z^3-1)(z+2)}{(z^4-1)^2} &= \frac{1}{2} \frac{1}{z^2-1} - \frac{1}{2} \frac{1}{z^2+1} \\
 &\quad + \frac{1}{4} \left\{ \frac{2z^3-z-1}{(z^2-1)^2} + \frac{2z^3-z-1}{(z^2+1)^2} - \frac{2z^3-z-1}{z^2-1} + \frac{2z^3-z-1}{z^2+1} \right\} \\
 &= \frac{1}{2} \frac{1}{z^2-1} - \frac{1}{2} \frac{1}{z^2+1} \\
 &\quad + \frac{1}{4} \left\{ \frac{2z(z^2-1)+z-1}{(z^2-1)^2} + \frac{2z(z^2+1)-3z-1}{(z^2+1)^2} \right. \\
 &\quad \left. - \frac{2z(z^2-1)+z-1}{z^2-1} + \frac{2z(z^2+1)-3z-1}{z^2+1} \right\} \\
 &= \frac{1}{2} \frac{1}{z^2-1} - \frac{1}{2} \frac{1}{z^2+1} \\
 &\quad + \frac{1}{4} \left\{ \frac{2z}{z^2-1} + \frac{z-1}{(z^2-1)^2} + \frac{2z}{z^2+1} - \frac{3z+1}{(z^2+1)^2} - 2z \right. \\
 &\quad \left. - \frac{z-1}{z^2-1} + 2z - \frac{3z+1}{z^2+1} \right\} \\
 &= \frac{1}{2} \frac{1}{z^2-1} - \frac{1}{2} \frac{1}{z^2+1} \\
 &\quad + \frac{1}{4} \left\{ \frac{z+1}{z^2-1} + \frac{z-1}{(z^2-1)^2} - \frac{z+1}{z^2+1} - \frac{3z+1}{(z^2+1)^2} \right\} \\
 &= \frac{1}{2} \left\{ \frac{1}{2} \frac{1}{z-1} - \frac{1}{2} \frac{1}{z+1} \right\} - \frac{1}{4} \frac{z+3}{z^2+1} + \frac{1}{4} \frac{1}{z-1} \\
 &\quad + \frac{1}{4} \cdot \frac{1}{(z-1)(z+1)^2} - \frac{1}{4} \cdot \frac{3z+1}{(z^2+1)^2} \\
 &= \frac{1}{2} \frac{1}{z-1} - \frac{1}{4} \frac{1}{z+1} + \frac{1}{4} \frac{1}{(z-1)(z+1)^2} - \frac{1}{4} \frac{z+3}{z^2+1} - \frac{1}{4} \frac{3z+1}{(z^2+1)^2}.
 \end{aligned}$$

Now,

$$\frac{1}{4} \cdot \frac{1}{(z-1)(z+1)^2} = \frac{1}{16} \cdot \frac{1}{z-1} - \frac{1}{8} \cdot \frac{1}{(z+1)^2} + \frac{A}{z+1},$$

where

$$\begin{aligned}
 \frac{A}{z+1} &= \frac{1}{16} \cdot \frac{1}{(z-1)(z+1)^2} \{4 - (z+1)^2 + 2(z-1)\} \\
 &= \frac{1}{16} \cdot \frac{1}{(z-1)(z+1)^2} \{-z^2 - 2z + 2z + 4 - 1 - 2\} \\
 &= \frac{1}{16} \cdot \frac{1}{(z^2-1)(z+1)} \{-(z^2-1)\} = -\frac{1}{16} \cdot \frac{1}{z+1},
 \end{aligned}$$

which gives by insertion,

$$\begin{aligned}\frac{(z^3-1)(z+2)}{(z^4-1)^2} &= \left(\frac{1}{2} + \frac{1}{16}\right) \frac{1}{z-1} - \frac{5}{16} \frac{1}{z+1} - \frac{1}{8} \frac{1}{(z+1)^2} - \frac{1}{4} \frac{z+3}{z^2+1} - \frac{1}{4} \frac{3z+1}{(z^2+1)^2} \\ &= \frac{9}{16} \frac{1}{z-1} - \frac{5}{16} \frac{1}{z+1} - \frac{1}{8} \frac{1}{(z+1)^2} - \frac{1}{4} \frac{z+3}{z^2+1} - \frac{1}{4} \frac{3z+1}{(z^2+1)^2}.\end{aligned}$$

Thus we have found the real decomposition.

COMPLEX DECOMPOSITION. Since

$$\begin{aligned}-\frac{1}{4} \cdot \frac{z+3}{z^2+1} - \frac{1}{4} \cdot \frac{3z+1}{(z^2+1)^2} &= -\frac{1}{4} \cdot \frac{(z+3)(z^2+1) + (3z+1)}{(z^2+1)^2} \\ &= -\frac{1}{4} \cdot \frac{z^3 + 3z^2 + z + 3 + 3z + 1}{(z^2+1)^2} \\ &= -\frac{1}{4} \cdot \frac{z^3 + 3z^2 + 4z + 4}{(z-i)^2(z+i)^2}\end{aligned}$$

is the only term with complex roots, it is by the complex decomposition sufficient to decompose

$$\frac{z^3 + 3z^2 + 4z + 4}{(z-i)^2(z+i)^2}.$$



#1
in eco-friendly
attitude

**STUDY AT
LINKÖPING UNIVERSITY, SWEDEN**
RANKED AMONG TOP 50 UNIVERSITIES UNDER 50

Interested in Strategy and Management in International Organisations? Kick-start your career with a master's degree from Linköping University, Sweden.

→ **Click here!**

 **Linköping University**

It is seen by the standard procedure that the decomposition must contain

$$\begin{aligned} \frac{i^3 + 3i^2 + 4i + 4}{(2i)^2} \cdot \frac{1}{(z-i)^3} &= \frac{(-i)^3 + 3(-i)^2 + 4(-i) + 4}{(-2i)^2} \cdot \frac{1}{(z+i)^2} \\ &= -\frac{1}{4}(1+3i) \frac{1}{(z-i)^2} - \frac{1}{4}(1-3i) \frac{1}{(z+i)^2}. \end{aligned}$$

It follows by a small computation that this expression is equal to

$$\begin{aligned} &-\frac{1}{4} \frac{1}{2} (z^2 + 1)^2 \{ (1+3i)(z+i) + (1-3i)(z-i)^2 \} \\ &= -\frac{1}{4} \frac{1}{(z^2+1)^2} \cdot 2 \operatorname{Re} \{ (1+3i)(z+i)^2 \} \\ &= -\frac{1}{2} \frac{1}{(z^2+1)^2} \operatorname{Re} \{ (1+3i)(z^2+2iz-1) \} \\ &= -\frac{1}{2} \frac{1}{(z^2+1)^2} \{ z^2 - 6z - 1 \}, \end{aligned}$$

thus the remainder term is

$$\begin{aligned} &\frac{z^3 + 3z^2 + 4z + 4}{(z^2+1)^2} + \frac{1}{2} \cdot \frac{1}{(z^2+1)^2} \{ z^2 - 6z - 1 \} \\ &= \frac{1}{2} \cdot \frac{1}{(z^2+1)^2} \{ 2z^3 + 6z^2 + 8z + 8 + z^2 - 6z - 1 \} \\ &= \frac{1}{2} \frac{1}{(z^2+1)^2} \{ 2z^3 + 7z^2 + 2z + 7 \} = \frac{2z+7}{2(z^2+1)} = \frac{2z+7}{2(z-i)(z+i)} \\ &= \frac{7+2i}{2(2i)} \cdot \frac{1}{z-i} + \frac{7-2i}{2(-2i)} \cdot \frac{1}{z+i} = \frac{7+2i}{4i} \cdot \frac{1}{z-i} + \frac{7-2i}{-4i} \cdot \frac{1}{z+i} \\ &= \frac{2-7i}{4} \cdot \frac{1}{z-i} + \frac{2+7i}{4} \cdot \frac{1}{z+i}. \end{aligned}$$

By insertion of these expression we get

$$\frac{z^3 + 3z^2 + 4z + 4}{(z-i)^2(z+i)^2} = \frac{2-7i}{4} \cdot \frac{1}{z-i} + \frac{2+7i}{4} \cdot \frac{1}{z+i} - \frac{1+3i}{4} \cdot \frac{1}{(z-i)^2} - \frac{1-3i}{4} \cdot \frac{1}{(z+i)^2},$$

and the complex decomposition becomes

$$\begin{aligned} \frac{(z^3-1)(z+2)}{(z^4-1)^2} &= \frac{9}{16} \frac{1}{z-1} - \frac{5}{16} \frac{1}{z+1} - \frac{1}{8} \frac{1}{(z+1)^2} \\ &\quad - \frac{2-7i}{16} \frac{1}{z-i} - \frac{2+7i}{16} \frac{1}{z+i} + \frac{1+3i}{16} \frac{1}{(z-i)^2} + \frac{1-3i}{16} \frac{1}{(z+i)^2}. \end{aligned}$$

ALTERNATIVELY one may use that $z=1$ is a simple pole, and that $z=i, -1, -i$ are double poles, and that we can write

$$\begin{aligned} \frac{(z^3-1)(z+2)}{(z^4-1)^2} &= \frac{(z-1)(z^2+1+1)(z+2)}{(z-1)^2(z-i)^2(z+1)^2(z+i)^2} = \frac{(z^2+z+1)(z+2)}{(z-1)(z+1)^2(z^2+1)^2} \\ &= \frac{(z^3-1)(z+2)}{(z-1)^2(z+1)^2(z^2+1)^2} = \frac{(z^3-1)(z+2)}{(z^2-1)^2(z-i)^2(z+i)^2}, \end{aligned}$$

where we in the following always shall use that expression which is the most convenient on in a given situation.

The coefficient of $\frac{1}{z-1}$ is found by the standard procedure:

$$\lim_{z \rightarrow 1} \frac{(z^2 + z + 1)(z + 1)}{(z^2 + 1)^2 (z + 1)^2} = \frac{3 \cdot 3}{2^2 \cdot 2^2} = \frac{9}{16}.$$

This is also the case of the coefficient of $\frac{1}{(z+1)^2}$:

$$\lim_{z \rightarrow -1} \frac{(z^2 + z + 1)(z + 2)}{(z - 1)(z^2 + 1)^2} = \frac{(1 - 1 + 1)(-1 + 2)}{(-2)(1 + 1)^2} = \frac{1 \cdot 1}{(-2) \cdot 2^2} = -\frac{1}{8}.$$

We find the coefficient of $\frac{1}{z+1}$ by using a residue formula for $n = 2$ and $j = 1$,

$$\begin{aligned} & \lim_{z \rightarrow -1} \frac{d}{dz} \left\{ \frac{(z^3 - 1)(z + 2)}{(z - 1)^2 (z^2 + 1)^2} \right\} \\ &= \lim_{z \rightarrow -1} \left\{ \frac{3z^2(z+2) + (z^3-1) \cdot 1}{(z-1)^2 (z^2+1)^2} - 2 \frac{(z^3-1)(z+2)}{(z-1)^3 (z^2+1)^2} - 2 \frac{(z^3-1)(z+2)2z}{(z-1)^2 (z^2+1)^3} \right\} \\ &= \frac{3 \cdot 1 \cdot 1 + (-2)}{2^2 \cdot 2^2} - 2 \frac{(-2) \cdot 1}{(-2)^3 \cdot 2^2} - 2 \frac{(-2) \cdot 1 \cdot (-2)}{(-2)^2 2^3} \\ &= \frac{3-2}{16} - \frac{2}{16} - \frac{4}{16} = -\frac{5}{16}. \end{aligned}$$

The coefficient of $\frac{1}{(z-i)^2}$ can also be found by the standard procedure,

$$\lim_{z \rightarrow i} \frac{(z^3 - 1)(z + 2)}{(z^2 - 1)^2 (z + i)^2} = \frac{(-i-1)(i+2)}{(-1-1)^2 (2i)^2} = \frac{-2+1+i(-1-2)}{4 \cdot (-4)} = \frac{1+3i}{16}.$$

The coefficient of $\frac{1}{z-i}$ is obtained by means of a residue formula, where $n = 2$ and $j = 1$:

$$\begin{aligned} & \lim_{z \rightarrow i} \frac{d}{dz} \left\{ \frac{(z^3 - 1)(z + 2)}{(z^2 - 1)^2 (z + i)^2} \right\} \\ &= \lim_{z \rightarrow i} \left\{ \frac{3z^2(z+2) + (z^3-1)}{(z^2-1)^2 (z+i)^2} - 2 \frac{(z^3-1)(z+2)2z}{(z^2-1)^3 (z+i)^2} - 2 \frac{(z^3-1)(z+2)}{(z^2-1)^2 (z+i)^3} \right\} \\ &= \frac{3(-1)(2+i) + (-i-1)}{(-2)^2 (2i)^2} - 2 \frac{-i-1)(i+2)2i}{(-2)^3 (2i)^2} - 2 \frac{(-i-1)(i+2)}{(-2)^2 (2i)^3} \\ &= \frac{6+3i+1+i}{16} + \frac{2 \cdot 2i(1+i)(2+i)}{(-8)(-4)} + 2 \frac{(1+i)(2+i)}{4(-8i)} \\ &= \frac{7+4i}{16} + \frac{2i(1+i)(2+i)}{16} + \frac{i(1+i)(2+i)}{16} \\ &= \frac{1}{16} \{7+4i+3i(2-1+3i)\} = \frac{1}{16} \{7+4i+3i-9\} = \frac{-2+7i}{16}. \end{aligned}$$

The fractional function

$$\frac{(z^3 - 1)(z + 2)}{(z^4 - 1)^2}$$

has real coefficients, so the remaining two coefficients of $\frac{1}{(z + i)^2}$ and $\frac{1}{z + i}$ respectively, are obtained by complex conjugations, so summing up we get as before,

$$\begin{aligned} \frac{(z^3 - 1)(z + 2)}{(z^4 - 1)^2} &= \frac{9}{16} \frac{1}{z - 1} - \frac{5}{16} \frac{1}{z + 1} - \frac{1}{8} \frac{1}{(z + 1)^2} \\ &\quad - \frac{2 - 7i}{16} \frac{1}{z - i} - \frac{2 + 7i}{16} \frac{1}{z + i} + \frac{1 + 3i}{16} \frac{1}{(z - i)^2} + \frac{1 - 3i}{16} \frac{1}{(z + i)^2}. \end{aligned}$$

(c) It follows directly by the standard procedure that

$$\frac{1}{(z^2 - 1)(z + 2)} = \frac{1}{(z - 1)(z + 2)(z + 1)} = \frac{1}{6} \frac{1}{z - 1} - \frac{1}{2} \frac{1}{z + 1} + \frac{1}{3} \frac{1}{z + 2},$$

and this is at the same time both the real and the complex decomposition.

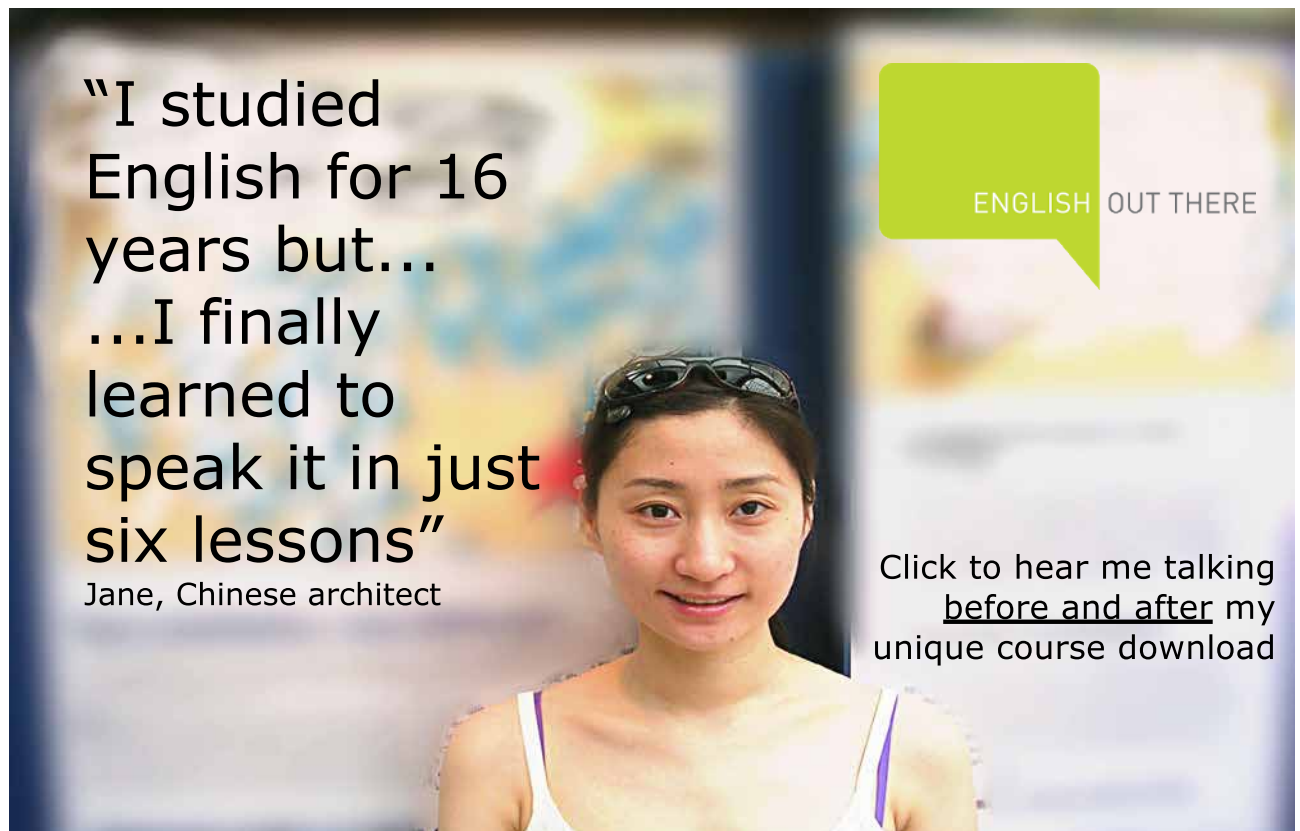

"I studied English for 16 years but...
...I finally learned to speak it in just six lessons"

Jane, Chinese architect

ENGLISH OUT THERE

Click to hear me talking before and after my unique course download



Example 3.7 *Put*

$$\alpha_k = \exp\left(\frac{2i\pi k}{n}\right), \quad k = 0, 1, \dots, n-1.$$

Prove that

$$\frac{n}{z^n - 1} = \sum_{k=0}^{n-1} \frac{\alpha_k}{z - \alpha_k} = \frac{\alpha_0}{z - \alpha_0} + \frac{\alpha_1}{z - \alpha_1} + \dots + \frac{\alpha_{n-1}}{z - \alpha_{n-1}}.$$

Here $z^n - 1$ has the n (simple) roots $\alpha_0, \alpha_1, \dots, \alpha_{n-1}$, so the decomposition gives in principal,

$$\frac{n}{z^n - 1} = \frac{A_0}{z - \alpha_0} + \frac{A_1}{z - \alpha_1} + \dots + \frac{A_{n-1}}{z - \alpha_{n-1}},$$

where $\alpha_k^n = 1$ for every $k = 0, 1, \dots, n-1$. The coefficients A_k are given by some residue formula,

$$A_k = n \cdot \lim_{z \rightarrow \alpha_k} \frac{z - \alpha_k}{z^n - 1} = \frac{n}{\lim_{z \rightarrow \alpha_k} \frac{z^n - 1}{z - \alpha_k}} = \frac{n}{n \alpha_k^{n-1}} = \frac{\alpha_k}{\alpha_k^n} = \alpha_k,$$

and the claim is proved.

Example 3.8 Two half lines L_1 and L_2 are given in the complex plane \mathbb{C} by

$$L_1 = \{z \mid \operatorname{Im}(z) = 0 \wedge \operatorname{Re}(z) \leq 2\}, \quad L_2 = \{z \mid \operatorname{Im}(z) = -1 \wedge \operatorname{Re}(z) \leq 0\}.$$

Given some C^1 -curve \mathcal{K} in $\Omega = \mathbb{C} \setminus \{L_1 \cup L_2\}$ with initial point $z = -2i$ and end point $z = 2i$. Compute

$$\int_{\mathcal{K}} \frac{2z - 6 - i}{(z - 2)(z + i)} dz.$$

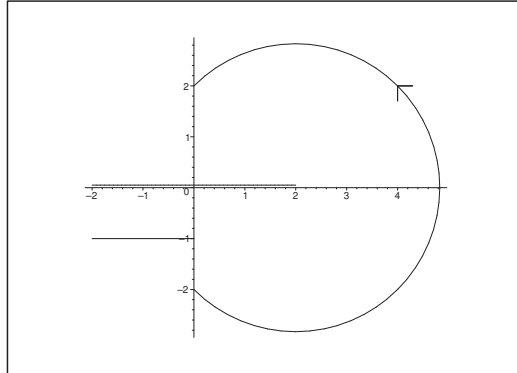

Figure 1: A possible curve \mathcal{K} from $-2i$ to $2i$ without intersecting the lines L_1 and L_2 .

We get by a decomposition,

$$\frac{2z - 6 - i}{(z - 2)(z + i)} = -\frac{1}{z - 2} + \frac{3}{z + i},$$

so if the curve \mathcal{K} lies in Ω , then

$$\begin{aligned} \int_{\mathcal{K}} \frac{2z - 6 - i}{(z - 2)(z + i)} dz &= \int_{\mathcal{K}} \left\{ -\frac{1}{z - 2} + \frac{3}{z + i} \right\} dz = [-\operatorname{Log}(z - 2) + 3\operatorname{Log}(z + i)]_{-2i}^{2i} \\ &= -\operatorname{Log}(-2 + 2i) + 3\operatorname{Log}(3i) + \operatorname{Log}(-2 - 2i) - 3\operatorname{Log}(-i) \\ &= \left\{ \ln |-2 + 2i| + i \frac{3\pi}{4} \right\} + 3 \left\{ \ln 3 + i \frac{\pi}{2} \right\} + \left\{ \ln |-2 - 2i| - i \frac{3\pi}{4} \right\} - 3 \left\{ \ln 1 - i \frac{\pi}{2} \right\} \\ &= -\frac{3\pi}{2} + 3 \ln 3 + 3i\pi = 3 \ln 3 + i \frac{3\pi}{2}, \end{aligned}$$

because \mathcal{K} lies in the domains of $\operatorname{Log}(z - 2)$ and $\operatorname{Log}(z + i)$.

4 The exponential function and the logarithm function

Example 4.1 Find every complex number z , which fulfils the equation

$$e^{2z+4i} = 3\sqrt{3} + 3i,$$

and indicate the solution which has the smallest module.

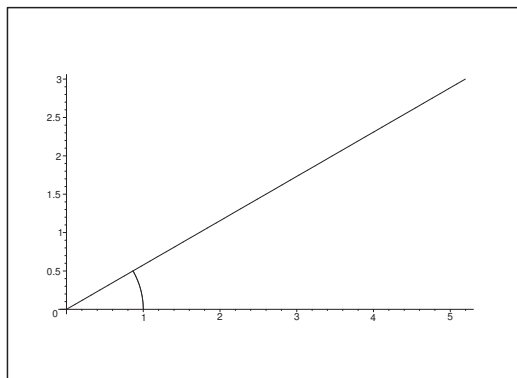

Figure 2: The vector $3\sqrt{3} + 3i$ of length 6 and corresponding angle $\frac{\pi}{6}$.

Since

$$|3\sqrt{3} + 3i| = \sqrt{27 + 9} = 6,$$

it follows that

$$3\sqrt{3} + 3i = 6 \left\{ \frac{\sqrt{3}}{2} + i \frac{1}{2} \right\} = 6 \exp\left(i \frac{\pi}{6}\right) = \exp\left(\ln 6 + i \left\{ \frac{\pi}{6} + 2p\pi \right\}\right), \quad p \in \mathbb{Z}.$$

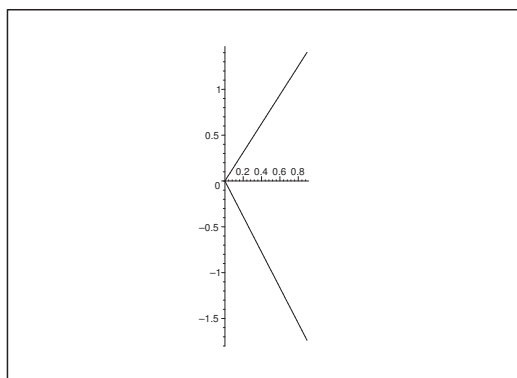

Figure 3: The solutions, when $p = 0$ and $p = 1$.

We have already taken care of the uncertainty of the exponent modulo $2\pi i$, so we conclude that

$$2z + 4i = \ln 6 + i \left\{ \frac{\pi}{6} + 2p\pi \right\}, \quad p \in \mathbb{Z},$$

thus

$$z = \frac{1}{2} \ln 6 + i \left\{ \frac{\pi}{12} - 2 + p\pi \right\}, \quad p \in \mathbb{Z}.$$

Now,

$$\frac{\pi}{12} - 2 \approx -1,738 \quad \text{and} \quad \frac{\pi}{12} - 2 + 1 \cdot \pi \approx 1,403,$$

so we conclude from the figure that the smallest module (i.e. the smallest absolute value) is obtained when $p = 1$ (and not when $p = 0$). Hence, the solution of smallest module is given by

$$z_0 = \frac{1}{2} \ln 6 + i \left\{ \frac{\pi}{12} - 2 + \pi \right\} = \frac{1}{2} \ln 6 + i \left\{ \frac{13\pi}{12} - 2 \right\}.$$

Example 4.2 Describe the streamlines for the complex potential

$$F(z) = e^z,$$

where $y \in [0, \pi]$.

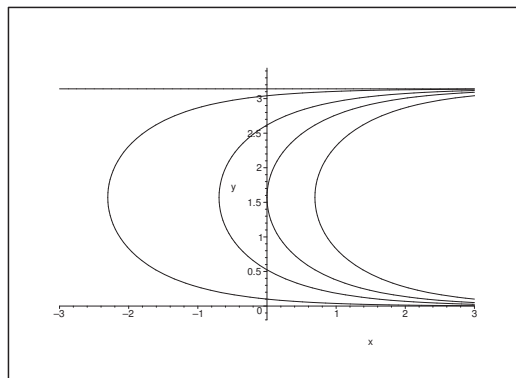

Figure 4: Some streamlines for the potential $F(z) = e^z$.

The stream function is given by

$$\psi(x, y) = \text{Im}(e^z) = e^x \sin y.$$

Clearly, $y = 0$ or $y = \pi$ correspond to $\psi(x, y) = 0$.

If $y \in]0, \pi[$, then

$$\psi(x, y) = e^x \sin y > 0.$$

Hence, the streamlines are given by

$$\psi(x, y) = e^x \sin y = c > 0,$$

thus

$$x = \ln \left(\frac{c}{\sin y} \right), \quad y \in]0, \pi[, \quad c \in \mathbb{R}_+,$$

because it is here easier to express x as a function of y than *vice versa*.

Example 4.3 Prove that

$$2\sqrt{2} \exp \left(\frac{\pi i}{12} \right) = (\sqrt{3} + 1) + i(\sqrt{3} - 1).$$

HINT: Apply

$$\frac{1}{12} = \frac{1}{3} - \frac{1}{4}.$$

Using the hint we get

$$\begin{aligned} 2\sqrt{2} \exp \left(\frac{\pi i}{12} \right) &= 2\sqrt{2} \cdot \exp \left(\frac{\pi i}{3} \right) \cdot \exp \left(-\frac{\pi i}{4} \right) = 2\sqrt{2} \cdot \left(\cos \frac{\pi}{3} + i \sin \frac{\pi}{3} \right) \cdot \left(\cos \frac{\pi}{4} - i \sin \frac{\pi}{4} \right) \\ &= 2\sqrt{2} \cdot \left(\frac{1}{2} + i \frac{\sqrt{3}}{2} \right) \left(\frac{1}{\sqrt{2}} - i \frac{1}{\sqrt{2}} \right) = (1 + i\sqrt{3})(1 - i) = (1 + \sqrt{3}) + i(\sqrt{3} - 1). \end{aligned}$$



Excellent Economics and Business programmes at:
**university of
 groningen**





**“The perfect start
of a successful,
international career.”**

CLICK HERE
to discover why both socially
and academically the University
of Groningen is one of the best
places for a student to be

www.rug.nl/feb/education



Example 4.4 Compute

$$\oint_{|z|=R} \frac{\operatorname{Log} z}{z^2} dz,$$

by considering the line integral along the curve \mathcal{C} with the parametric description

$$z(t) = R e^{it}, \quad t \in]-\pi, \pi], \quad R > 0.$$

In this case it is not possible to apply Cauchy's integral theorem, so instead we insert the parametric description. This gives

$$\begin{aligned} \oint_{|z|=R} \frac{\operatorname{Log} z}{z^2} dz &= \int_{-\pi}^{\pi} \frac{\operatorname{Log}(R e^{it})}{R^2 e^{2it}} \cdot i R e^{it} dt = i \int_{-\pi}^{\pi} \frac{\ln R + it}{R e^{it}} dt \\ &= \frac{i}{R} \int_{-\pi}^{\pi} (\ln R + it)(\cos t - i \sin t) dt \\ &= \frac{i}{R} \int_{-\pi}^{\pi} \{(\ln R \cdot \cos t + t \sin t) + i(t \cos t - \ln R \cdot \sin t)\} dt \\ &= \frac{i}{R} \int_{-\pi}^{\pi} \{t \cdot \sin t + i t \cdot \cos t\} dt = -\frac{1}{R} \int_{-\pi}^{\pi} t \cdot \cos t dt + \frac{i}{R} \int_{-\pi}^{\pi} t \cdot \sin t dt \\ &= 0 + \frac{i}{R} \left[-t \cdot \cos t + \int \cos t dt \right]_{-\pi}^{\pi} = \frac{i}{R} \{-\pi \cdot (-1) + (-\pi) \cdot (-1)\} = \frac{2\pi i}{R}. \end{aligned}$$

ALTERNATIVELY we may use the following shorter version,

$$\begin{aligned} \oint_{|z|=R} \frac{\operatorname{Log} z}{z^2} dz &= \int_{-\pi}^{\pi} \frac{\operatorname{Log}(R e^{it})}{R^2 e^{2it}} \cdot i R e^{it} dt = i \int_{-\pi}^{\pi} \frac{\ln R + it}{R e^{it}} dt \\ &= i \int_{-\pi}^{\pi} \frac{\ln R}{R} \cdot e^{-it} dt - \frac{1}{R} \int_{-\pi}^{\pi} t e^{-it} dt \\ &= \frac{\ln R}{R} [-e^{-it}]_{-\pi}^{\pi} - \frac{1}{R} \left[+t \cdot \frac{1}{-i} e^{-it} \right]_{-\pi}^{\pi} + \frac{1}{R} \cdot \left(-\frac{1}{i} \right) \int_{-\pi}^{\pi} e^{-it} dt \\ &= 0 - \frac{1}{R} \cdot i \{ \pi \cdot (-1) - (-\pi) \cdot (-1) \} + 0 = \frac{2\pi i}{R}. \end{aligned}$$

Example 4.5 Let $\Omega = \mathbb{C} \setminus (\mathbb{R}_- \cup \{0\})$. Find the value of the limit

$$\lim_{y \rightarrow 0^+} \{ \operatorname{Log}(a + iy) - \operatorname{Log}(a - iy) \},$$

partly when $a \in \mathbb{R}_+$, and partly when $a \in \mathbb{R}_-$

What happens if $a = 0$?

1) If $a \in \mathbb{R}_+$, then $\operatorname{Log}(a + iy)$ is continuous in $y \in \mathbb{R}$, thus

$$\lim_{y \rightarrow 0^+} \{ \operatorname{Log}(a + iy) - \operatorname{Log}(a - iy) \} = 0 \quad \text{for } a \in \mathbb{R}_+.$$

- 2) If $a \in \mathbb{R}_-$, then $\text{Log}(a + iy)$ tends towards $\ln |a| + i\pi$ for $y \rightarrow 0+$, and $\text{Log}(a - iy)$ tends towards $\ln |a| - i\pi$ for $y \rightarrow 0+$, hence

$$\lim_{y \rightarrow 0+} \{ \text{Log}(a + iy) - \text{Log}(a - iy) \} = 2\pi i \quad \text{for } a \in \mathbb{R}_-.$$

- 3) If $a = 0$, then

$$\lim_{y \rightarrow 0+} \{ \text{Log}(iy) - \text{Log}(-iy) \} = \frac{\pi}{2}i - \left(-\frac{\pi}{2}i\right) = \pi i, \quad \text{for } a = 0.$$

Example 4.6 Given the function

$$f(z) = \text{Log}(z^2 + 2),$$

where Log denotes the principal branch of the logarithm, and denote by A the largest domain in \mathbb{C} , in which f is analytic.

- 1) Find and sketch the domain A . Then find the derivative $f'(z)$ as a function of z .
- 2) Let $\gamma : [0, 1] \rightarrow A$ denote any differentiable curve in A of initial point $\gamma(0) = 0$ and end point $\gamma(1) = -1 + i$. Prove that

$$\int_{\gamma} \frac{2z}{z^2 + 2} dz = \ln \sqrt{2} - i \frac{\pi}{4}.$$

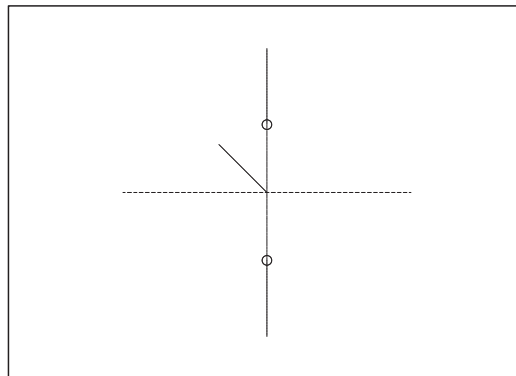

Figure 5: The set A with the two slits given by $x = 0$ and $|y| \geq \sqrt{2}$ and with a possible path of integration γ from 0 to $-1 + i$.

- 1) The principal branch Log of the logarithm is analytic in the plane with a slit along the negative real axis

$$\mathbb{C} \setminus \{z \in \mathbb{C} \mid \text{Re}(z) \leq 0, \text{Im}(z) = 0\},$$

so if we put $g(z) = z^2 + 2$, then the composed function $f = \text{Log} \circ g$ is analytic in the set

$$\begin{aligned} A &= \mathbb{C} \setminus \{z \in \mathbb{C} \mid \text{Re}(z^2 + 2) \leq 0, \text{Im}(z^2 + 2) = 0\} \\ &= \mathbb{C} \setminus \{z = x + iy \mid x^2 - y^2 + 2 \leq 0, 2xy = 0\}. \end{aligned}$$

It follows that the exception set is defined by either $x = 0$ or $y = 0$. Clearly, $y = 0$ is not possible, so we get $x = 0$. Then we must have in the exception set that $|y| \geq \sqrt{2}$. We have prove that

$$A = \mathbb{C} \setminus \{iy \mid y \leq -\sqrt{2} \text{ or } y \geq \sqrt{2}\}.$$

The function $f(z) = \text{Log}(z^2 + 2)$ is analytic in A , so it follows by the chain rule that

$$f'(z) = \frac{2z}{z^2 + 2}, \quad z \in A.$$

- 2) Let $\gamma : [0, 1] \rightarrow A$ be a parametric description of any differentiable curve from $0 \in A$ to $-1 + i \in A$. The integrand is equal to $f'(z)$, found above, so the primitive is given by

$$\begin{aligned} \int_{\gamma} f'(z) dz &= f(\gamma(1)) - f(\gamma(0)) = f(-1 + i) - f(0) = \text{Log}((-1 + i)^2 + 2) - \text{Log}(0^2 + 2) \\ &= \text{Log}(-2i + 2) - \text{Log} 2 = \text{Log}(1 - i) = \frac{1}{2} \ln 2 - i\frac{\pi}{4}, \end{aligned}$$

where we have used that $\text{Log} 2 = \ln 2$.



In the past four years we have drilled

89,000 km

That's more than **twice** around the world.

Who are we?
We are the world's largest oilfield services company¹. Working globally—often in remote and challenging locations—we invent, design, engineer, and apply technology to help our customers find and produce oil and gas safely.

Who are we looking for?
Every year, we need thousands of graduates to begin dynamic careers in the following domains:

- Engineering, Research and Operations
- Geoscience and Petrotechnical
- Commercial and Business

What will you be?

careers.slb.com

Schlumberger

¹Based on Fortune 500 ranking 2011. Copyright © 2015 Schlumberger. All rights reserved.

Example 4.7 Define

$$F(z) = \exp(z^2), \quad z \in \mathbb{C}.$$

(a) Describe for every real constant $R > 0$ the set of points $z \in \mathbb{C}$, for which

$$|F(z)| = R.$$

Show in particular on a figure

$$\{z \in \mathbb{C} \mid |F(z)| = R\}$$

for representative values of R .

Let

$$z = r e^{i\theta}, \quad r \geq 0, \quad \theta \in]-\pi, \pi],$$

be the description in polar coordinates of z .

(b) Find every $\theta_0 \in]-\pi, \pi]$, such that

$$F(z) = F(r \exp(i\theta_0))$$

never takes on a negative, real value on the half line from 0,

$$\ell_{\theta_0} = \{z = r \exp(i\theta_0) \mid r \geq 0\}.$$

(c) For any other $\theta \in]-\pi, \pi]$ find the smallest

$$r = r(\theta) > 0,$$

on the half line ℓ_θ , such that

$$F(z) = F(r \exp(i\theta)) \in \mathbb{R}_-, \quad z \in \ell_\theta.$$

(d) Prove that the function $r(\theta)$ defined in (c) has a minimum > 0 , and then find the largest open disc

$$B(0, R) = \{z \in \mathbb{C} \mid |z| < R\},$$

for which $F(z) \notin \mathbb{R}_-$ for every $z \in B(0, R)$.

(a) It follows from

$$|F(z)| = |\exp(z^2)| = |\exp(x^2 - y^2 + 2i xy)| = \exp(x^2 - y^2) = R > 0,$$

that

$$x^2 - y^2 = \ln R \in \mathbb{R},$$

which is the equation of a system of hyperbolas, supplied with the straight lines $y = x$ and $y = -x$, both corresponding to $R = 1$.

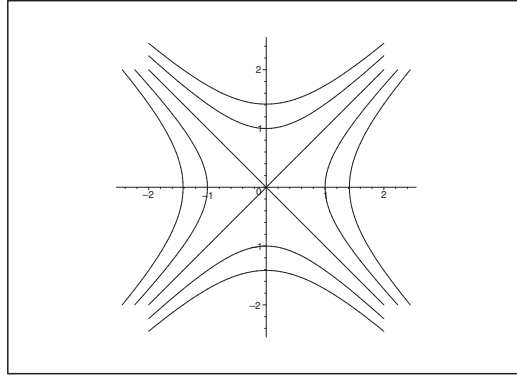

Figure 6: Some level curves $F(z) = e^{x^2 - y^2} = R > 0$.

(b) By using polar coordinates we get the description

$$F(r e^{i\theta}) = \exp(r^2 \cos 2\theta) \cdot \exp(i r^2 \sin 2\theta).$$

This represents a negative number, if and only if

$$(1) \quad r^2 \sin 2\theta = \pi + 2p\pi, \quad p \in \mathbb{Z}.$$

Since $r \geq 0$ varies, the only possibility that (1) is never fulfilled is when $\sin 2\theta = 0$, thus if and only if

$$\theta_0 \in \left\{ -\frac{\pi}{2}, 0, \frac{\pi}{2}, \pi \right\},$$

because we have assumed that $\theta_0 \in]-\pi, \pi]$.

The four corresponding half lines are the four half axes (the positive and negative x and y axes) from 0.

It follows immediately that

$$F(x) = \exp(x^2) > 0 \quad \text{for every } x \in \mathbb{R},$$

and

$$F(iy) = \exp(-y^2) > 0 \quad \text{for every } y \in \mathbb{R},$$

hence $F(z) \notin \mathbb{R}_-$ for z on any of the coordinate axes.

(c) If

$$\theta \in]-\pi, \pi] \setminus \left\{ -\frac{\pi}{2}, 0, \frac{\pi}{2}, \pi \right\},$$

then $\sin 2\theta \neq 0$, and it follows from (1) that

$$r^2 = \frac{\pi + 2p\pi}{\sin 2\theta}, \quad p \in \mathbb{Z}.$$

Then the smallest possible $r = r(\theta)$ is given by

$$r(\theta)^2 = \min_{p \in \mathbb{Z}} \frac{\pi + 2p\pi}{\sin 2\theta} = \frac{\pi}{|\sin 2\theta|},$$

thus

$$r(\theta) = \sqrt{\frac{\pi}{|\sin 2\theta|}}, \quad \theta \in]-\pi, \pi] \setminus \left\{ -\frac{\pi}{2}, 0, \frac{\pi}{2}, \pi \right\}.$$

(d) It follows from the expression of $r(\theta)$ in (c) that $r(\theta_1)$ is smallest, when $|\sin 2\theta_1|$ is largest, thus when $|\sin 2\theta_1| = 1$, corresponding to

$$\theta_1 \in \left\{ -\frac{3\pi}{4}, -\frac{\pi}{4}, \frac{\pi}{4}, \frac{3\pi}{4} \right\},$$

so the minimum value is

$$r(\theta_1) = \sqrt{\frac{\pi}{1}} = \sqrt{\pi}.$$

American online

LIGS University

is currently enrolling in the
Interactive Online **BBA, MBA, MSc,**
DBA and PhD programs:

- ▶ enroll **by September 30th, 2014** and
- ▶ **save up to 16%** on the tuition!
- ▶ pay in 10 installments / 2 years
- ▶ Interactive **Online education**
- ▶ visit www.ligsuniversity.com to find out more!

Note: LIGS University is not accredited by any nationally recognized accrediting agency listed by the US Secretary of Education. More info [here](#).





Click on the ad to read more

Now,

$$F(\sqrt{\pi} e^{i\theta_1}) = e^{\pi \cos 2\theta_1} e^{i\pi \sin 2\theta_1} = e^0 \cdot e^{\pm i\pi} = -1,$$

so it follows that the largest open disc $B(0, R)$, for which $F(z) \notin \mathbb{R}_-$ for all $z \in B(0, R)$, is given by

$$B(0, \sqrt{\pi}) = \{z \in \mathbb{C} \mid |z| < \sqrt{\pi}\},$$

corresponding to $R = \sqrt{\pi}$.

Example 4.8 Let

$$F(z) = \exp\left(\frac{1}{z}\right), \quad z \in \mathbb{C} \setminus \{0\}.$$

(a) Describe for every value of $R > 0$ the point set

$$\{z \in \mathbb{C} \setminus \{0\} \mid |F(z)| = R\},$$

and sketch a representative number of the set.

(b) Find the set of points A , for which $F(z)$ is real, thus

$$A = \{z \in \mathbb{C} \setminus \{0\} \mid F(z) \in \mathbb{R}\}.$$

The set A is naturally into decomposed into infinitely many components of connection. Sketch a representative number of these.

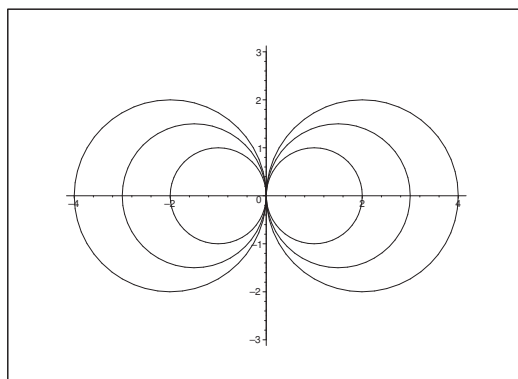

Figure 7: (a) Some of the curves $|F(z)| = R$.

(a) If $z \neq 0$, then

$$0 < R = |F(z)| = \exp\left(\operatorname{Re}\left(\frac{1}{z}\right)\right) = \exp\left(\frac{x}{x^2 + y^2}\right),$$

hence

$$\frac{x}{x^2 + y^2} = \ln R, \quad (z, y) \neq (0, 0).$$

If $R = 1$, then we get the two half lines $x = 0, y \neq 0$ of the y axis.

If $R \neq 1$, then

$$x^2 + y^2 = \frac{1}{\ln R} x,$$

which we write as

$$\left\{ x - \frac{1}{2 \ln R} \right\}^2 + y^2 = \left\{ \frac{1}{2 \ln R} \right\}^2, \quad (x, y) \neq (0, 0),$$

i.e. some circles (with exceptional points)

$$\text{centrum: } \left(\frac{1}{2 \ln R}, 0 \right) \quad \text{and} \quad \text{radius: } \left| \frac{1}{2 \ln R} \right|.$$

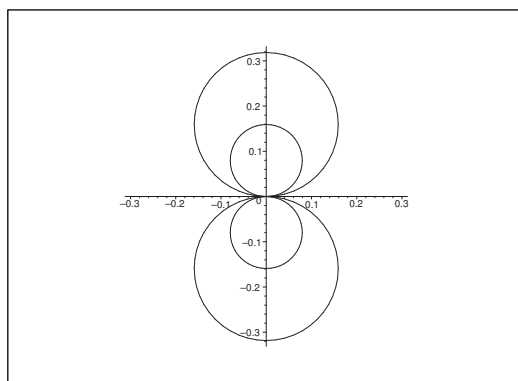

Figure 8: Some of the circles of radius $\frac{1}{2\pi|p|}$.

(b) If $z \neq 0$, then

$$F(z) = \exp\left(\frac{1}{z}\right) \in \mathbb{R},$$

when

$$\text{Im}\left(\exp\left(\frac{1}{z}\right)\right) = \exp\left(\frac{x}{x^2 + y^2}\right) \sin\left(-\frac{y}{x^2 + y^2}\right) = 0,$$

hence

$$\frac{y}{x^2 + y^2} = p\pi, \quad p \in \mathbb{Z}.$$

When $p = 0$ we get $y = 0$, $x \neq 0$, thus the positive and then negative real half axes.
If $p \neq 0$, then

$$x^2 + \left\{ y - \frac{1}{2p\pi} \right\}^2 = \left\{ \frac{1}{2p\pi} \right\}^2, \quad (x, y) \neq (0, 0),$$

which describes some circles (with exceptional points) of

$$\text{centrum: } \left(0, \frac{1}{2p\pi} \right) \quad \text{and} \quad \text{radius: } \frac{1}{2\pi|p|}, \quad p \in \mathbb{Z} \setminus \{0\}.$$

Note that the radius in this case only go through

$$\left\{ \frac{1}{2\pi n} \mid n \in \mathbb{N} \right\},$$

and not all of \mathbb{R}_+ .

Example 4.9 1) Prove that we have at any point z on the horizontal lines

$$\text{Im}(z) = \pi + 2n\pi, \quad n \in \mathbb{Z},$$

that $e^z < 0$, and hence $|e^z - 1| > 1$.

2) Prove that we have at any point z on the vertical lines

$$\text{Re}(z) = r, \quad |r| > 1,$$

have

$$|e^z - 1| > \frac{1}{2}.$$

1) If $\text{Im}(z) = \pi + 2n\pi$, $n \in \mathbb{Z}$, then

$$z = x + i(\pi + 2n\pi), \quad x \in \mathbb{R} \text{ og } n \in \mathbb{Z},$$

hence

$$e^z = e^{x+i(\pi+2n\pi)} = -e^x < 0, \quad n \in \mathbb{Z}.$$

Then it is trivial that $|e^z - 1| > 1$ for every such z .

2) If $\text{Re}(z) = r$, $|r| > 1$, then

$$z = r + iy, \quad |r| > 1 \text{ og } y \in \mathbb{R},$$

hence

$$|e^z - 1| = |e^r e^{iy} - 1| \geq |e^r - 1| \geq \left\{ \begin{array}{ll} e - 1 & \text{for } r \geq 1 \\ 1 - \frac{1}{e} & \text{for } r \leq -1 \end{array} \right\} > \frac{1}{2}.$$

Example 4.10 1) Find the solutions of the equation

$$z^2 = 3 + i4$$

in the form $z = x + iy$.

2) Find the solutions of the equation

$$e^{iz} - (1 + i)e^{-iz} = i.$$

in the form $z = x + iy$.

1) It follows from

$$z^2 = 3 + 4i = 2^2 + i^2 + 2 \cdot 2i = (2 + i)^2,$$

that the solutions are

$$z_1 = 2 + i \quad \text{og} \quad z_2 = -2 - i.$$

.....Alcatel-Lucent 

www.alcatel-lucent.com/careers

What if you could build your future and create the future?

One generation's transformation is the next's status quo. In the near future, people may soon think it's strange that devices ever had to be "plugged in." To obtain that status, there needs to be "The Shift".



- 2) When we multiply the equation by $e^{iz} \neq 0$, then we get after a small rearrangement the equivalent equation of second order in e^{iz} ,

$$(e^{iz})^2 - i e^{iz} - (1 + i) = 0.$$

The solution is

$$e^{iz} = \frac{1}{2} \left\{ i \pm \sqrt{-1 + 4(1 + i)} \right\} = \frac{1}{2} \left\{ i \pm \sqrt{3 + 4i} \right\} = \frac{1}{2} \{i \pm (2 + i)\} = \begin{cases} 1 + i, \\ -1. \end{cases}$$

From here we get the two families of solutions

$$z_{1,p} = \frac{1}{i} \log(1 + i) = \frac{1}{i} \left\{ \frac{1}{2} \ln 2 + i \left(\frac{\pi}{4} + 2p\pi \right) \right\} = \frac{\pi}{4} + 2p\pi - \frac{i}{2} \ln 2, \quad p \in \mathbb{Z},$$

and

$$z_{2,p} = \frac{1}{i} \log(-1) = \frac{1}{i} \cdot i \{ \pi + 2p\pi \} = \pi + 2p\pi, \quad p \in \mathbb{Z}.$$

Example 4.11 Find the solutions of the equation

$$e^{iz} - 2e^{-iz} = 3i.$$

A multiplication by $e^{iz} \neq 0$ follows by a rearrangement gives the equivalent equation of second order in e^{iz} ,

$$(e^{iz})^2 - 3i \cdot e^{iz} - 2 = 0,$$

with the solutions

$$e^{iz} = \frac{1}{2} \{ 3i \pm \sqrt{-9 + 4 \cdot 2} \} = \frac{1}{2} \{ 3i \pm i \} = \begin{cases} 2i, \\ i. \end{cases}$$

Then finally,

$$z = \begin{cases} \frac{1}{i} \log(2i) &= \frac{1}{i} \left\{ \ln 2 + i \left(\frac{\pi}{2} + 2p\pi \right) \right\} &= \frac{\pi}{2} + 2p\pi - i \ln 2, \\ \frac{1}{i} \log(i) &= \frac{1}{i} \cdot i \left(\frac{\pi}{2} + 2p\pi \right) &= \frac{\pi}{2} + 2p\pi, \end{cases} \quad p \in \mathbb{Z}.$$

Example 4.12 Consider the principal branch of the square root

$$f(z) = \sqrt{z} = \exp\left(\frac{1}{2} \operatorname{Log} z\right),$$

and also the function

$$g(z) = f(1 - z^3).$$

1) Find the domains of analyticity A of f , and B of g , and sketch B .
Find the derivative $g'(z)$ for $z \in B$.

2) Denote by Γ any oriented closed curve in B , and find the value of the line integral

$$\oint_{\Gamma} g'(z) dz.$$

Let γ denote any oriented curve in B of initial point $z = -i$ and end point $z = i$. Prove that

$$\int_{\gamma} g'(z) dz = i 2\sqrt[4]{2} \sin\left(\frac{\pi}{8}\right).$$

1) Clearly,

$$A = \mathbb{C} \setminus \{z \in \mathbb{C} \mid \operatorname{Re}(z) \leq 0, \operatorname{Im}(z) = 0\}.$$

The exceptional set of g is given by $1 - z^3 \in \mathbb{R}_- \cup \{0\}$, hence $z^3 \in [1, +\infty[$, and thus

$$B = \mathbb{C} \setminus \left\{ z \in \mathbb{C} \mid z = r \cdot e^{i\theta}, r \geq 1, \theta \in \left\{ -\frac{2\pi}{3}, 0, \frac{2\pi}{3} \right\} \right\}.$$

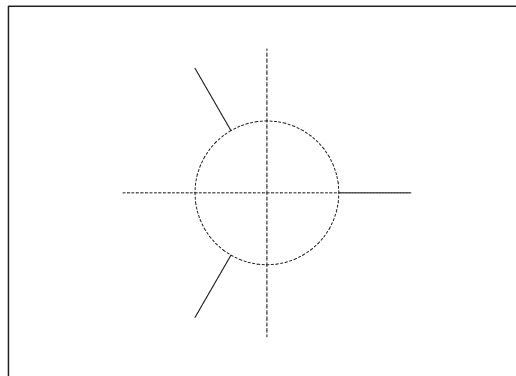

Figure 9: The set B with its three slits.

Then we get by the chain rule,

$$\begin{aligned} g'(z) &= f'(1 - z^3) \cdot (-3z^2) = \frac{1}{2} \cdot \frac{1}{1 - z^3} \sqrt{1 - z^3} \cdot (-3z^2) \\ &= -\frac{3}{2} \cdot \frac{z^2}{1 - z^3} \sqrt{1 - z^3} \quad \text{for } z \in B. \end{aligned}$$

- 2) Now, $g'(z)$ is analytic in B , and Γ is a closed curve in B , so it follows from *Cauchy's integral theorem* that

$$\oint_{\Gamma} g'(z) dz = 0.$$

Furthermore, $\pm i \in B$, so

$$\begin{aligned} \int_{\gamma} g'(z) dz &= [g(z)]_{-i}^i = f(1-i) - f(1+i) = f\left(\sqrt{2} \cdot \exp\left(-i\frac{\pi}{4}\right)\right) - f\left(\sqrt{2} \cdot \exp\left(i\frac{\pi}{4}\right)\right) \\ &= \sqrt[4]{2} \cdot \exp\left(-i\frac{\pi}{8}\right) - \sqrt[4]{2} \cdot \exp\left(i\frac{\pi}{8}\right) = 2i \sqrt[4]{2} \cdot \sin\left(\frac{\pi}{8}\right). \end{aligned}$$

Example 4.13 Denote the principal branch of the logarithm by Log .

- 1) Prove that $F(z) = z \text{Log } z - z$ is a primitive of Log in the slitted plane

$$D^* = \mathbb{C} \setminus]-\infty, 0].$$

- 2) Denote by γ a curve in D^* of initial point $z_I = 1$ and end point $z_T = i$. Explain why the value of

$$\int_{\gamma} \text{Log } z dz$$

is independent of the path γ and find the value.

- 1) We see that $F(z) = z \text{Log } z - z$ is precisely defined and analytic in $D^* = \mathbb{C} \setminus]-\infty, 0]$. Hence, it suffices to prove that

$$F'(z) = \text{Log } z \quad \text{for } z \in D^*.$$

This follows from

$$F'(z) = \text{Log } z + z \cdot \frac{1}{z} - 1 = \text{Log } z.$$

- 2) Clearly, $\text{Log } z$ is analytic in D^* , and since $F(z)$ is a primitive of $\text{Log } z$, we get

$$\begin{aligned} \int_{\gamma} \text{Log } z dz &= [F(z)]_1^i = 1 \cdot \text{Log } 1 - 1 - i \cdot \text{Log } i + i = 0 - 1 - i \left\{ i \cdot \left(\frac{\pi}{2}\right) \right\} + i \\ &= -1 + \frac{\pi}{2} + i. \end{aligned}$$

5 Trigonometric and hyperbolic functions

Example 5.1 Find the real and imaginary parts of

(a) $\cosh(\pi i)$, (b) e^i , (c) $\sin(\pi i)$, (d) $\sinh(1 + i)$.

(a) Since $\cosh(\pi i) = \cos \pi = -1$, we get

$$\operatorname{Re}(\cosh(\pi i)) = -1 \quad \text{and} \quad \operatorname{Im}(\cosh(\pi i)) = 0.$$

(b) Since $e^i = \cos 1 + i \sin 1$, we get

$$\operatorname{Re}(e^i) = \cos 1 \quad \text{and} \quad \operatorname{Im}(e^i) = \sin 1.$$

(c) Since $\sin(\pi i) = i \sinh \pi$, we get

$$\operatorname{Re}(\sin(\pi i)) = 0 \quad \text{og} \quad \operatorname{Im}(\sin(\pi i)) = \sinh \pi.$$

(d) Since

$$\sinh(1 + i) = \sinh 1 \cdot \cos 1 + i \cosh 1 \cdot \sin 1,$$

we get

$$\operatorname{Re}(\sinh(1 + i)) = \sinh 1 \cdot \cos 1, \quad \operatorname{Im}(\sinh(1 + i)) = \cosh 1 \cdot \sin 1.$$



Maastricht University

*Leading
in Learning!*

**Join the best at
the Maastricht University
School of Business and
Economics!**

Top master's programmes

- 33rd place Financial Times worldwide ranking: MSc International Business
- 1st place: MSc International Business
- 1st place: MSc Financial Economics
- 2nd place: MSc Management of Learning
- 2nd place: MSc Economics
- 2nd place: MSc Econometrics and Operations Research
- 2nd place: MSc Global Supply Chain Management and Change

Sources: Keuzegids Master ranking 2013; Elsevier 'Beste Studies' ranking 2012; Financial Times Global Masters in Management ranking 2012

**Maastricht
University is
the best specialist
university in the
Netherlands
(Elsevier)**

**Visit us and find out why we are the best!
Master's Open Day: 22 February 2014**

www.mastersopenday.nl



Example 5.2 Prove that

$$2e^{i\theta} \cos \theta = 1 + e^{2i\theta}.$$

Then prove that

$$\int_0^\pi \cos^3 \theta \cos 3\theta \, d\theta = \frac{\pi}{8}.$$

It follows from

$$2e^{i\theta} \cos \theta = 2e^{i\theta} \cdot \frac{1}{2} \{e^{i\theta} + e^{-i\theta}\} = 1 + e^{2i\theta},$$

that

$$e^{i\theta} \cos \theta = \frac{1}{2} \{1 + e^{2i\theta}\}.$$

By taking the third power of this relation, we get

$$e^{3i\theta} \cos^3 \theta = \cos 3\theta \cdot \cos^3 \theta + i \sin 3\theta \cdot \cos^3 \theta = \frac{1}{8} (1 + e^{2i\theta})^3,$$

hence

$$\int_0^\pi \cos^3 \theta \cos 3\theta \, d\theta = \operatorname{Re} \left\{ \frac{1}{8} \int_0^\pi (1 + e^{2i\theta})^3 \, d\theta \right\} = \frac{1}{8} \operatorname{Re} \int_0^\pi \{1 + 3e^{2i\theta} + 3e^{4i\theta} + e^{6i\theta}\} \, d\theta = \frac{\pi}{8}.$$

Example 5.3 Prove that the map $w = \cos z$ usually maps the straight lines $\operatorname{Re}(z) = k$ into hyperbolas, and the straight lines $\operatorname{Im}(z) = k$ into ellipses in the w -plane.

Find the values of $k \in \mathbb{R}$ for which we instead get a straight line, a half line or an interval.

When we separate

$$w = u + iv = \cos x \cdot \cosh y - i \sin x \cdot \sinh y,$$

into the real and the imaginary part, we get

$$u(x, y) = \cos x \cdot \cosh y \quad \text{and} \quad v(x, y) = -\sin x \cdot \sinh y.$$

Put $\operatorname{Re}(z) = x = k$. If $k = \frac{\pi}{2} + p\pi$, $p \in \mathbb{Z}$, then

$$u = 0 \quad \text{og} \quad v = (-1)^{p+1} \sinh y, \quad y \in \mathbb{R},$$

thus the image is in this case the v -axis $u = 0$.

If $k = p\pi$, $p \in \mathbb{Z}$, then

$$u = (-1)^p \cosh y \quad \text{and} \quad v = 0, \quad y \in \mathbb{R}.$$

In this case the image is one of the two half lines $] -\infty, 1]$ and $[1, +\infty[$ on the u -axis, depending on whether p is odd or even.

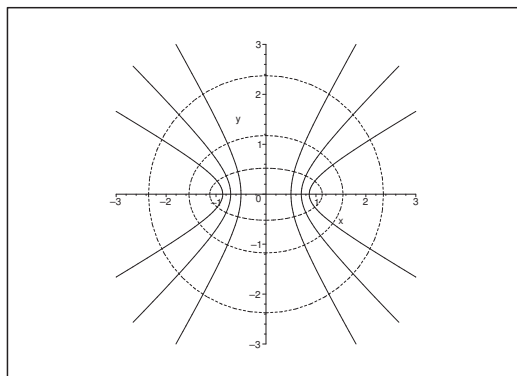

Figure 10: The two orthogonal systems of curves.

If $k \neq p \cdot \frac{\pi}{2}$, $p \in \mathbb{Z}$, the $\cos k \cdot \sin k \neq 0$, so

$$\frac{u}{\cos k} = \cosh y, \quad \frac{v}{\sin k} = -\sinh y.$$

When we eliminate the parameter y we get an equation of a hyperbola

$$\frac{u^2}{\cos^2 k} - \frac{v^2}{\sin^2 k} = 1.$$

Now let $\text{Im}(z) = y = k$. If $k = 0$, then

$$(u, v) = (\cos x, 0), \quad x \in \mathbb{R},$$

and the image is the interval $[-1, 1]$ on the u -axis.

If $k \neq 0$, then

$$\frac{u}{\cosh k} = \cos x, \quad \frac{v}{\sinh k} = -\sin x, \quad x \in \mathbb{R}.$$

When we eliminate the parameter x we obtain an equation of an ellipse

$$\frac{u^2}{\cosh^2 k} + \frac{v^2}{\sinh^2 k} = 1.$$

Example 5.4 Prove that

$$\left| \oint_{|z|=1} \frac{\sin z}{z^2} dz \right| \leq 2\pi e.$$

It follows from

$$\sin z = \sin(x + iy) = \sin x \cdot \cosh y + i \cos x \cdot \sinh y,$$

that

$$\begin{aligned} |\sin z|^2 &= \sin^2 x \cdot \cosh^2 y + \cos^2 x \cdot \sinh^2 y = \sin^2 x \cdot \cosh^2 y + \cos^2 x \cdot (\cosh^2 y - 1) \\ &= \cosh^2 y - \cos^2 x. \end{aligned}$$

Therefore, if $|z| \leq 1$, then we get the estimate

$$|\sin z| = \sqrt{\cosh^2 y - \cos^2 x} \leq \cosh y \leq e^y \leq e.$$

Then

$$\left| \oint_{|z|=1} \frac{\sin z}{z^2} dz \right| \leq \max_{|z|=1} \left| \frac{\sin z}{|z|^2} \right| \cdot 2\pi \leq \frac{2\pi \cosh 1}{1^2} < 2\pi e.$$

Remark 5.1 We shall here demonstrate – although it will later follow more systematically – that

$$\oint_{|z|=1} \frac{\sin z}{z^2} dz = 2\pi i.$$

First method. If one already knows a little of calculus of residues, then the task is quite simple: We see that $z = 0$ is a simple pole of $\frac{\sin z}{z^2}$, because $\sin z$ has a simple zero for $z = 0$, and because $z = 0$ is the only singularity inside the circle $|z| = 1$. Hence by the theorem of residues,

$$\oint_{|z|=1} \frac{\sin z}{z^2} dz = 2\pi i \operatorname{res} \left(\frac{\sin z}{z^2}; 0 \right) = 2\pi i \lim_{z \rightarrow 0} \frac{\sin z}{z} = 2\pi i.$$

Second method. It is actually possible already with the present theory available to find the value.

Since $\frac{\sin z}{z^2}$ is analytic in $\mathbb{C} \setminus \{0\}$, it follows by introducing the smaller path of integration $|z| = r < 1$, run through once in the positive direction, $\oint_{|z|=r}$, and once in the negative direction, $\oint_{|z|=r}^*$, that

$$\begin{aligned} \oint_{|z|=1} \frac{\sin z}{z^2} dz &= \left\{ \oint_{|z|=1} \frac{\sin z}{z^2} dz + \oint_{|z|=r}^* \frac{\sin z}{z^2} dz \right\} + \oint_{|z|=r} \frac{\sin z}{z^2} dz \\ &= 0 + \oint_{|z|=r} \frac{\sin z}{z^2} dz = \lim_{r \rightarrow 0^+} \oint_{|z|=r} \frac{\sin z}{z^2} dz, \end{aligned}$$

where we have used *Cauchy's integral theorem for the multiple connected domain* between the two circles.

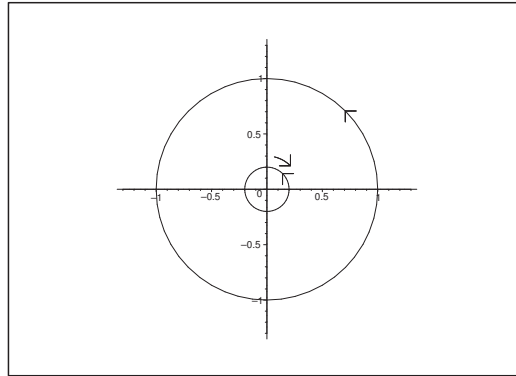

Figure 11: The oriented path of integration $|z| = 1$, and the two additional paths of integration $|z| = r$ with opposite orientation in the second method.

Then by a Taylor expansion,

$$\sin z = z - \frac{1}{6} z^3 + o(z^3),$$

hence by insertion,

$$\oint_{|z|=1} \frac{\sin z}{z^2} dz = \lim_{r \rightarrow 0^+} \frac{1}{z^2} \left\{ z - \frac{1}{6} z^3 + o(z^3) \right\} dz = \lim_{r \rightarrow 0^+} \oint_{|z|=r} \frac{1}{z} dz - \lim_{r \rightarrow 0^+} \oint_{|z|=r} \left\{ \frac{1}{6} z + o(z) \right\} dz.$$

> Apply now

**REDEFINE YOUR FUTURE
AXA GLOBAL GRADUATE
PROGRAM 2015**

redefining / standards 

agence edf. © Photonstop

It is well-known that

$$\oint_{|z|=r} \frac{1}{z} dz = \int_0^{2\pi} \frac{1}{e^{i\theta}} i e^{i\theta} d\theta = 2\pi i,$$

for every $r > 0$, and since

$$\left| \oint_{|z|=r} \left\{ \frac{1}{6} z + o(z) \right\} dz \right| \leq \left\{ \frac{1}{6} r + o(r) \right\} \cdot 2\pi r \rightarrow 0 \quad \text{for } r \rightarrow 0+,$$

it follows by taking the limit that

$$\oint_{|z|=1} \frac{\sin z}{z^2} dz = 2\pi i + 0 = 2\pi i. \quad \diamond$$

Example 5.5 Find the value of

$$\int_0^{3i} \cos^2(\pi i z) \sin^2(\pi i z) dz.$$

One should not be fooled by the rather complicated integrand. This is only an easy exercise in finding a primitive, because the integrand of course is analytic in \mathbb{C} , and hence independent of the path of integration:

$$\begin{aligned} \int_0^{3i} \cos^2(\pi i z) \sin^2(\pi i z) dz &= \frac{1}{4} \int_0^{3i} \sin^2(2\pi i z) dz = \frac{1}{4} \int_0^{3i} \frac{1}{2} \{1 - \cos(4\pi i z)\} dz \\ &= \frac{1}{8} \int_0^{3i} \{1 - \cosh(4\pi z)\} dz = \frac{1}{8} \cdot 3i - \frac{1}{8} \cdot \frac{1}{4\pi} [\sinh(4\pi z)]_0^{3i} \\ &= \frac{3i}{8} - \frac{1}{32\pi} \sinh(12\pi i) = \frac{3i}{8} - \frac{i}{32\pi} \sin(12\pi) = \frac{3i}{8}. \end{aligned}$$

Example 5.6 Describe the streamlines of the complex potential

$$F(z) = \sinh z, \quad y \in [0, \pi].$$

The stream function is here given by

$$\psi(x, y) = \text{Im}(F(z)) = \text{Im}(\sinh z) = \cosh x \cdot \sin y.$$

Clearly, $y = 0$ and $y = \pi$ are streamlines corresponding to $\psi(x, y) = 0$.

If $y \in]0, \pi[$, then $\psi(x, y) > 0$, and the streamlines are given by

$$\psi(x, y) = \cosh x \cdot \sin y = c \in \mathbb{R}_+.$$

When we continue our investigation, we must split into the three cases,

$$x \in]0, 1[, \quad c = 1, \quad \text{and} \quad c \in]1, +\infty[.$$

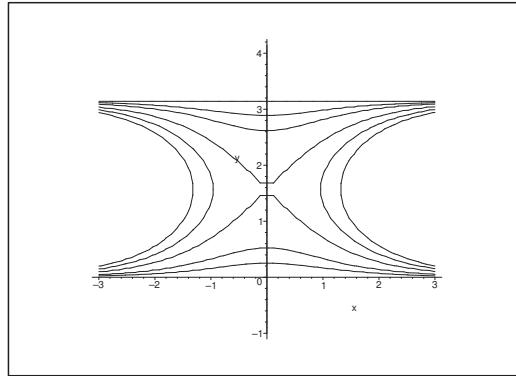

Figure 12: Sketch of the streamlines.

1) If $c \in]0, 1[$, then y is expressed as functions of x by

$$y = \operatorname{Arcsin}\left(\frac{c}{\cosh x}\right) \quad \text{and} \quad y = \pi - \operatorname{Arcsin}\left(\frac{c}{\cosh x}\right).$$

2) If $c = 1$, then we get the two so-called *separatrices*, most easily described by

$$x = \pm \operatorname{Arcosh}\left(\frac{1}{\sin y}\right) = \pm \ln\left(\frac{1 + \sqrt{1 - \sin^2 y}}{\sin y}\right) = \pm \ln\left(\frac{1 \pm \cos y}{\sin y}\right) = \pm \ln\left(\cot \frac{y}{2}\right),$$

because

$$\ln\left(\frac{1 - \cos y}{\sin y}\right) = -\ln\left(\frac{1 + \cos y}{\sin y}\right),$$

and we can combine the two \pm signs into one.

3) If $c > 1$, we express x by y (the same trick is used on \pm):

$$x = \pm \operatorname{Arcosh}\left(\frac{c}{\sin y}\right) = \pm \ln\left(\frac{c + \sqrt{c^2 - \sin^2 y}}{\sin y}\right).$$

Example 5.7 Prove that the image of

$$D = \left\{z = x + iy \mid x \geq 0, 0 \leq y \leq \frac{\pi}{2}\right\}$$

by $f(z) = \cosh z$ is the closed first quadrant in the w -plane, and find the image of each of the three natural parts of the boundary ∂D of D by the map f .

It follows by a separation into real and imaginary parts of

$$u + iv = \cosh(x + iy) = \cosh x \cdot \cos y + i \sinh x \cdot \sin y,$$

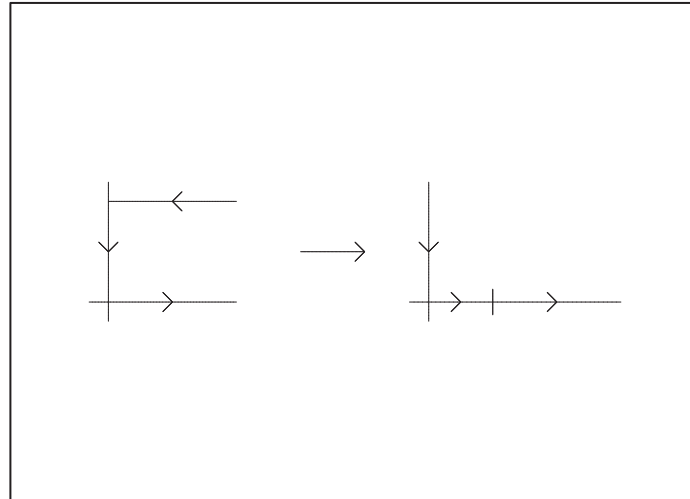
Figure 13: The domains D (to the left) and $f(D)$ (to the right).

that

$$u(x, y) = \cosh x \cdot \cos y, \quad v(x, y) = \sinh x \cdot \sin y.$$

The image of the part A_1 of the boundary, given by $x \geq 0$ and $y = \frac{\pi}{2}$, is

$$u\left(x, \frac{\pi}{2}\right) = 0, \quad v\left(x, \frac{\pi}{2}\right) = \sinh x \in [0, +\infty[\quad \text{for } x \in [0, +\infty[.$$

The image of the part A_2 of the boundary, given by $x = 0$ and $y \in \left[0, \frac{\pi}{2}\right]$, is

$$u(0, y) = \cos y, \quad v(0, y) = 0, \quad y \in \left[0, \frac{\pi}{2}\right].$$

The image of the part A_3 of the boundary, given by $x \geq 0$ and $y = 0$, is

$$u(x, 0) = \cosh x \in [1, +\infty[, \quad v(x, 0) = 0, \quad x \in [0, +\infty[.$$

It follows that the boundary of D is mapped into the boundary of the first quadrant.

Assume that $w = u + iv$ belongs to the first quadrant, thus $u > 0$ and $v > 0$. We shall prove that one can find a $z \in D$, such that $\cosh z = w$. Consider

$$\log\left(w + \sqrt{w^2 - 1}\right) = \log\left(u + iv + \sqrt{u^2 - v^2 - 1 + 2iuv}\right).$$

It follows from $2uv > 0$ that $u^2 - v^2 - 1 + 2iuv$ lies in the upper half plane. By choosing the slit of the square root along the negative real axis and fixing the square root of a positive number as positive, we obtain that both $u + iv$ and $\sqrt{u^2 - v^2 - 1 + 2iuv}$ lie in the first quadrant, hence their sum will also lie in the first quadrant, so the principal argument of the sum lies in $\left]0, \frac{\pi}{2}\right[$.

Clearly, $\text{Log}(w + \sqrt{w^2 - 1})$ belongs to D for $|w|$ large and w in the first quadrant,

$$\ln\left(\left|w + \sqrt{w^2 - 1}\right|\right) > 0,$$

so we conclude that the image of the first quadrant by Arcosh is precisely D .

Example 5.8 Express $\tan z$ by means of the exponential function.
Apply the result in order to prove that

$$\tan z = \frac{\sin 2x + i \sinh 2y}{\cos 2x + \cosh 2y}.$$

It follows from the definition that

$$\tan z = \frac{\sin z}{\cos z} = \frac{e^{iz} - e^{-iz}}{e^{iz} + e^{-iz}} = \frac{1}{i} \frac{e^{iz} - e^{-iz}}{e^{iz} + e^{-iz}} = \frac{1}{i} \frac{e^{2iz} - 1}{e^{2iz} + 1}.$$

Empowering People. Improving Business.

BI Norwegian Business School is one of Europe's largest business schools welcoming more than 20,000 students. Our programmes provide a stimulating and multi-cultural learning environment with an international outlook ultimately providing students with professional skills to meet the increasing needs of businesses.

BI offers four different two-year, full-time Master of Science (MSc) programmes that are taught entirely in English and have been designed to provide professional skills to meet the increasing need of businesses. The MSc programmes provide a stimulating and multi-cultural learning environment to give you the best platform to launch into your career.

- MSc in Business
- MSc in Financial Economics
- MSc in Strategic Marketing Management
- MSc in Leadership and Organisational Psychology

www.bi.edu/master

BI NORWEGIAN BUSINESS SCHOOL

EFMD EQUIS ACCREDITED



Then by some computation,

$$\begin{aligned}\tan z &= \frac{1}{i} \frac{e^{2iz} - 1}{e^{2iz} + 1} = \frac{1}{i} \frac{e^{-2y+2ix} - 1}{e^{-2y+2ix} + 1} \cdot \frac{e^{-2y-2ix} + 1}{e^{-2y-2ix} + 1} = \frac{1}{i} \frac{e^{-4y} + e^{-2y+2ix} - e^{-2y-2ix} - 1}{e^{-4y} + e^{-2y+2ix} + e^{-2y-2ix} + 1} \\ &= \frac{1}{i} \frac{e^{-2y} - e^{2y} + e^{2ix} - e^{-2ix}}{e^{-2y} + e^{2y} + e^{2ix} + e^{-2ix}} = \frac{i \cdot \frac{e^{2y} - e^{-2y}}{2} + \frac{e^{2ix} - e^{-2ix}}{2i}}{\frac{e^{2y} + e^{-2y}}{2} + \frac{e^{2ix} + e^{-2ix}}{2}} = \frac{\sin 2x + i \sinh 2y}{\cos 2x + \cosh 2y}.\end{aligned}$$

Note that $\cosh 2y \geq 1$, so the denominator is zero if and only if both $y = 0$ and $\cos 2x = -1$, so $\tan z$ is not defined in the points of \mathbb{C} , where

$$z = \frac{\pi}{2} + p\pi, \quad p \in \mathbb{Z},$$

which are the same exceptional points as in the real case.

Example 5.9 Assume that $f(t)$ is a continuous function on \mathbb{R} , and let $A \in \mathbb{R}_+$. Prove that

$$\int_{-A}^A f(t) \cos(zt) dt$$

is an analytic function in $z \in \mathbb{C}$.

Clearly, $f(t) \cos(zt)$ is uniformly continuous for $t \in [-A, A]$ for every fixed $z \in \mathbb{C}$, and since

$$\frac{\partial}{\partial z} \{f(t) \cos(zt)\} = -t \cdot f(t) \sin(zt)$$

also is uniformly continuous in $t \in [-A, A]$ for every fixed $z \in \mathbb{C}$, one may differentiate below the sign of integral with respect to the parameter $z \in \mathbb{C}$,

$$\frac{d}{dz} \int_{-A}^A f(t) \cos(zt) dt = \int_{-A}^A \frac{\partial}{\partial z} \{f(t) \cos(zt)\} dt = - \int_{-A}^A t \cdot f(t) \sin(zt) dt.$$

This proves that $\int_{-A}^A f(t) \cos(zt) dt$ is complex differentiable in \mathbb{C} with a continuous derivative, hence the integral is an analytic function in \mathbb{C} .

Example 5.10 Find the solutions $z \in \mathbb{C}$ of the equation

$$\tan z = i(1 + e^{iz}).$$

We put $w = e^{iz}$ for $z \in \mathbb{C}$. Then in particular, $w \in \mathbb{C} \setminus \{0\}$. By using the definition of $\tan z$,

$$\tan z = \frac{\sin z}{\cos z} = \frac{1}{i} \frac{e^{2iz} - 1}{e^{2iz} + 1} = \frac{1}{i} \frac{w^2 - 1}{w^2 + 1}.$$

Since we require that $\tan z$ is defined, we must have $w^2 \neq -1$. Hence,

$$w \in \mathbb{C} \setminus \{-i, 0, i\} = \Omega.$$

Then we put $w = e^{iz} \in \Omega$ into the given equation, and obtain after a rearrangement,

$$\begin{aligned} 0 &= i(1 + e^{iz}) - \tan z = i(1 + w) - \frac{1}{i} \frac{w^2 - 1}{w^2 + 1} = i \left\{ w + 1 + \frac{w^2 - 1}{w^2 + 1} \right\} = i(w + 1) \left\{ 1 + \frac{w - 1}{w^2 + 1} \right\} \\ &= i(w + 1) \cdot \frac{w^2 + 1 + w - 1}{w^2 + 1} = i \frac{(w + 1)^2 w}{w^2 + 1}, \end{aligned}$$

where we shall solve the equation for $w \in \Omega = \mathbb{C} \setminus \{-i, 0, i\}$.

It follows from $w \neq 0$ that $w = -1$ is the only possibility, corresponding to

$$w = e^{iz} = -1,$$

hence

$$z = \frac{1}{i} \log(-1) = \frac{1}{i} (i\pi + 2ip\pi) = \pi + 2p\pi, \quad p \in \mathbb{Z}.$$

The complete solution is

$$z = \pi + 2p\pi, \quad p \in \mathbb{Z}.$$

Example 5.11 Find all complex solutions of the equation

$$\{(1 + i) \cos z + (1 - i) \sin z\}^4 = 16i.$$

First we get

$$\begin{aligned} (1 + i) \cos z + (1 - i) \sin z &= \frac{\sqrt{2}}{2} \left\{ \exp\left(i \frac{\pi}{4}\right) \cdot (e^{iz} + e^{-iz}) - i \exp\left(-i \frac{\pi}{4}\right) \cdot (e^{iz} - e^{-iz}) \right\} \\ &= \frac{1}{\sqrt{2}} \left\{ \exp\left(i \frac{\pi}{4}\right) \cdot (e^{iz} + e^{-iz}) - \exp\left(i \frac{\pi}{4}\right) \cdot (e^{iz} - e^{-iz}) \right\} \\ &= \frac{1}{\sqrt{2}} \exp\left(i \frac{\pi}{4}\right) \cdot 2e^{-iz} = \sqrt{2} \cdot \exp\left(i \left\{ \frac{\pi}{4} - z \right\}\right). \end{aligned}$$

Then by insertion into the equation,

$$\{(1 + i) \cos z + (1 - i) \sin z\}^4 = 4 \exp(i\{\pi - 4z\}) = -4e^{-4iz} = 16i,$$

and the equation is reduced to

$$e^{4iz} = -\frac{4}{16i} = \frac{i}{4} = \exp\left(-2 \ln 2 + i \left\{ \frac{\pi}{2} + 2p\pi \right\}\right), \quad p \in \mathbb{Z}.$$

Then by taking the logarithm,

$$4iz = -2 \ln 2 + i \left\{ \frac{\pi}{2} + 2p\pi \right\}, \quad p \in \mathbb{Z},$$

and the complete solution becomes

$$z_p = \frac{\pi}{8} + p \frac{\pi}{2} + \frac{i}{2} \ln 2, \quad p \in \mathbb{Z}.$$

Example 5.12 Find the complete complex solution of the trigonometric equation

$$3 \cos 2z - 10 \cos z + 3.$$

It follows from

$$\begin{aligned} 0 &= 3 \cos 2z - 10 \cos z + 3 = 3(2 \cos^2 z - 1) - 10 \cos z + 3 \\ &= 6 \cos^2 z - 10 \cos z = 2 \cos z(3 \cos z - 5) \end{aligned}$$

that either $\cos z = 0$ the solution of which is $z = \frac{\pi}{2} + p_1\pi$, $p_1 \in \mathbb{Z}$, or $\cos z = \frac{5}{3}$. If we put $w = e^{iz}$, then the latter equation is written

$$0 = 2 \cos z - \frac{10}{3} = w + \frac{1}{w} - \frac{10}{3} = \frac{1}{w} \left\{ w^2 - \frac{10}{3} w + 1 \right\} = \frac{1}{w} \left\{ w - \frac{1}{3} \right\} \{w - 3\},$$

hence

$$iz = \pm \log 3 = \pm \ln 3 + 2p\pi i, \quad p \in \mathbb{Z}.$$

Summing up the equation has the solutions

$$z = \begin{cases} \frac{\pi}{2} + p_1\pi, \\ i \ln 3 + 2p_2\pi, \\ -i \ln 3 + 2p_2\pi, \end{cases} \quad p_1, p_2, p_3 \in \mathbb{Z}.$$

Example 5.13 Find all solutions of the equation

$$\sin z = i,$$

in the form $x + iy$.

We get by using the definition of $\sin z$,

$$i = \sin z = \frac{1}{2i} \{e^{iz} - e^{-iz}\} = \frac{1}{2i e^{iz}} \{e^{2iz} - 1\}.$$

If this is multiplied by $2i e^{iz} \neq 0$, then

$$e^{2iz} - 1 = -2 e^{iz},$$

hence by an addition of $2e^{iz} + 2$ and by interchanging the two sides of the equation

$$2 = (e^{iz})^2 + 2e^{iz} + 1 = \{e^{iz} + 1\}^2,$$

thus

$$e^{iz} = -1 \pm \sqrt{2} = \begin{cases} \sqrt{2} - 1 > 0, \\ -(\sqrt{2} + 1) < 0. \end{cases}$$

Finally, we get the solution

$$z = \begin{cases} \frac{1}{i} \log(\sqrt{2} - 1) = 2p\pi - i \ln(\sqrt{2} - 1), & p \in \mathbb{Z}, \\ \frac{1}{i} \log(-\sqrt{2} + 1) = \pi + 2p\pi - i \ln(\sqrt{2} + 1), & p \in \mathbb{Z}. \end{cases}$$

It follows from $(\sqrt{2} - 1)(\sqrt{2} + 1) = 1$ that

$$\ln(\sqrt{2} - 1) = -\ln(\sqrt{2} + 1),$$

so summing up the solution can be written

$$z = \frac{\pi}{2} + 2p\pi \pm \left\{ \frac{\pi}{2} - i \ln(\sqrt{2} + 1) \right\}, \quad p \in \mathbb{Z}.$$

Need help with your dissertation?

Get in-depth feedback & advice from experts in your topic area. Find out what you can do to improve the quality of your dissertation!

Get Help Now



Go to www.helpmyassignment.co.uk for more info



Click on the ad to read more

Example 5.14 Find all solutions of the equation

$$\tan z = 3i,$$

in the form $x + iy$.

The solutions are given by

$$\begin{aligned} z &= \arctan(3i) = \frac{1}{2i} \log \left(\frac{i - 3i}{i + 3i} \right) = \frac{1}{2i} \log \left(\frac{-2i}{4i} \right) = \frac{1}{2i} \log \left(-\frac{1}{2} \right) \\ &= \frac{1}{2i} \{ -\ln 2 + i(\pi + 2p\pi) \} = \frac{\pi}{2} + p\pi + \frac{i}{2} \ln 2, \quad p \in \mathbb{Z}. \end{aligned}$$

Example 5.15 Find all complex solutions of the equation

$$\cos z = 2\sqrt{2}i.$$

Since

$$2\sqrt{2}i = \cos z = \frac{1}{2} \{ e^{iz} + e^{-iz} \}$$

is equivalent with the equation of second degree

$$(e^{iz})^2 - 4\sqrt{2}i e^{iz} + 1 = 0$$

in e^{iz} , it follows by the well-known solution formula that

$$e^{iz} = 2\sqrt{2}i \pm \sqrt{-8-1} = (2\sqrt{2} \pm 3)i.$$

hence

$$z = \frac{1}{i} \log \left((2\sqrt{2} \pm 3)i \right) = \begin{cases} \frac{1}{i} \left\{ \ln(2\sqrt{2} + 3) + i \frac{\pi}{2} + 2pi\pi \right\}, \\ \frac{1}{i} \left\{ \ln(3 - 2\sqrt{2}) - i \frac{\pi}{2} + 2pi\pi \right\}, \end{cases}$$

and thus

$$z = \begin{cases} \frac{\pi}{2} + 2p\pi - i \ln(2\sqrt{2} + 3) = \frac{\pi}{2} + 2p\pi - 2i \ln(\sqrt{2} + 1), \\ -\frac{\pi}{2} + 2p\pi + i \ln(2\sqrt{2} + 3) = -\frac{\pi}{2} + 2p\pi + 2i \ln(\sqrt{2} + 1), \end{cases} \quad p \in \mathbb{Z}.$$

Summing up,

$$z = 2p\pi \pm \left\{ \frac{\pi}{2} - 2i \ln(\sqrt{2} + 1) \right\}, \quad p \in \mathbb{Z}.$$

Example 5.16 Find all solutions of the equation

$$\cos z = i\sqrt{3}.$$

It follows from

$$i\sqrt{3} = \cos z = \frac{1}{2} \{e^{iz} + e^{-iz}\},$$

by a rearrangement that we have the equivalent equation of second degree in e^{iz} ,

$$(e^{iz})^2 - 2i\sqrt{3} \cdot e^{iz} + 1 = 0.$$

The solution is

$$e^{iz} = i\sqrt{3} \pm \sqrt{-3-1} = i(\sqrt{3} \pm 2) = \begin{cases} i(2 + \sqrt{3}), \\ -i(2 - \sqrt{3}) = -\frac{i}{2 + \sqrt{3}}. \end{cases}$$

Hence

$$\begin{aligned} z &= \frac{1}{i} \log \left(i(\sqrt{3} \pm 2) \right) \\ &= \begin{cases} \frac{1}{i} \left\{ \ln(2 + \sqrt{3}) + i \left(\frac{\pi}{2} + 2p\pi \right) \right\} &= \frac{\pi}{2} + 2p\pi - i \ln(2 + \sqrt{3}), \\ \frac{1}{i} \left\{ -\ln(2 + \sqrt{3}) + i \left(-\frac{\pi}{2} + 2p\pi \right) \right\} &= -\frac{\pi}{2} + 2p\pi + i \ln(2 + \sqrt{3}), \end{cases} \end{aligned}$$

and summing up,

$$z = 2p\pi \pm \left\{ \frac{\pi}{2} - i \ln(2 + \sqrt{3}) \right\}, \quad p \in \mathbb{Z}.$$

Example 5.17 Given the functions

$$f(z) = \frac{1}{z^2} - 1 \quad \text{and} \quad g(z) = \mathcal{L}_0(z)$$

where \mathcal{L}_0 denotes the branch of the logarithm, which is defined by

$$\mathcal{L}_0 = \ln |z| + i \arg_0(z) \quad \text{where} \quad \arg_0(z) \in]0, 2\pi].$$

Find the domains of analyticity of the functions f , g and $h = g \circ f$.

Clearly, f is analytic in $\mathbb{C} \setminus \{0\}$, and g is analytic in

$$\mathbb{C} \setminus \{z \in \mathbb{C} \mid \operatorname{Im}(z) = 0 \text{ and } \operatorname{Re}(z) \geq 0\} = \mathbb{C} \setminus (\mathbb{R}_+ \cup \{0\}).$$

The exceptional set of $h = g \circ f$ is given by

$$\frac{1}{z^2} - 1 = a^2, \quad a \geq 0,$$

thus

$$z = \pm \frac{1}{\sqrt{1+a^2}}, \quad a \geq 0,$$

and the exceptional set is $] -\infty, -1] \cup [1, +\infty[$ on the real axis. Hence, h is defined in the set

$$\mathbb{C} \setminus \{z \in \mathbb{C} \mid |\operatorname{Im}(z)| = 0 \text{ og } |\operatorname{Re}(z)| \geq 1\}.$$



Brain power

By 2020, wind could provide one-tenth of our planet's electricity needs. Already today, SKF's innovative know-how is crucial to running a large proportion of the world's wind turbines.

Up to 25 % of the generating costs relate to maintenance. These can be reduced dramatically thanks to our systems for on-line condition monitoring and automatic lubrication. We help make it more economical to create cleaner, cheaper energy out of thin air.

By sharing our experience, expertise, and creativity, industries can boost performance beyond expectations.

Therefore we need the best employees who can meet this challenge!

The Power of Knowledge Engineering

Plug into The Power of Knowledge Engineering.
Visit us at www.skf.com/knowledge

SKF



6 Harmonic functions

Example 6.1 Prove that the function $u(x, y) = x^3 - 3xy^2$ is harmonic, and then find all the harmonic conjugated to $u(x, y)$.

Clearly, u belongs to the class $C^\infty(\mathbb{R}^2)$. Then by partial differentiation,

$$\frac{\partial u}{\partial x} = 3x^2 - 3y^2, \quad \frac{\partial^2 u}{\partial x^2} = 6x, \quad \text{and} \quad \frac{\partial u}{\partial y} = -6xy, \quad \frac{\partial^2 u}{\partial y^2} = -6x.$$

It follows that

$$\Delta u = \frac{\partial^2 u}{\partial x^2} + \frac{\partial^2 u}{\partial y^2} = 6x - 6x = 0,$$

hence $u(x, y)$ is harmonic.

Then by Cauchy-Riemann's equations,

$$\frac{\partial u}{\partial x} = \frac{\partial v}{\partial y} \quad \text{og} \quad \frac{\partial u}{\partial y} = -\frac{\partial v}{\partial x},$$

thus

$$\begin{aligned} v(x, y) &= \int \left\{ \frac{\partial v}{\partial x} dx + \frac{\partial v}{\partial y} dy \right\} + C = \int \left\{ -\frac{\partial u}{\partial y} dx + \frac{\partial u}{\partial x} dy \right\} + C \\ &= \int \left\{ -(-6xy)dx + (3x^2 - 3y^2) dy \right\} + C = \int \left\{ (6xy dx + 3x^2 dy) - 3y^2 dy \right\} dy + C \\ &= \int d \{ 3x^2 y - y^3 \} + C = 3x^2 y - y^3 + C, \end{aligned}$$

where $C \in \mathbb{R}$ is an arbitrary constant.

It is almost obvious that

$$u(x, y) + i v(x, y) = x^3 - 3xy^2 + i \{ 3x^2 y - y^3 \} = z^3 = f(z).$$

Example 6.2 Find the constant $a \in \mathbb{R}$, such that the function

$$u(x, y) = y^3 + ax^2 y$$

becomes harmonic.

Then find an harmonic conjugated function v of u , and describe $f(z) = u + iv$ as a function of z alone.

Clearly, $u \in C^\infty(\mathbb{R}^2)$ for every $a \in \mathbb{R}$, so u is harmonic, if and only if $\Delta u = 0$. It follows by a computation that

$$\Delta u = \frac{\partial^2 u}{\partial x^2} + \frac{\partial^2 u}{\partial y^2} = 6y + 2ay = 2(3 + a)y,$$

so Δu is identical zero, if and only if $a = -3$, in which case

$$u(x, y) = y^3 - 3x^2y.$$

Then we find the harmonic conjugated

$$\begin{aligned} v(x, y) &= \int_0^z \left\{ -\frac{\partial u}{\partial y} dx + \frac{\partial u}{\partial x} dy \right\} + C = \int_0^z \{ -(3y^2 - 3x^2) dx - 6xy dy \} + C \\ &= -\int_0^z \{ 3(y^2 dx + x dy^2) - d(x^3) \} + C = x^3 - 3xy^2 + C, \quad C \in \mathbb{R}, \end{aligned}$$

hence

$$\begin{aligned} f(z) &= u + iv = y^3 - 3x^2y + i(x^3 - 3xy^2) + iC = i\{x^3 + 3x^2iy + 3x(iy)^2 + (iy)^3\} + iC \\ &= i(x + iy)^3 + iC = iz^3 + iC, \quad C \in \mathbb{R}. \end{aligned}$$

ALTERNATIVELY,

$$f'(z) = \frac{\partial u}{\partial x} + i \frac{\partial v}{\partial x} = \frac{\partial u}{\partial x} - i \frac{\partial u}{\partial y} = -6xy - i(3y^2 - 3x^2) = 3u \{x^2 - y^2 + 2ixy\} = 3iz^2,$$

and then by finding a primitive,

$$f(z) = iz^3 + CD_1, \quad C_1 \in \mathbb{C}.$$

We conclude from

$$\operatorname{Re}(f(z)) = \operatorname{Re}(iz^3) + \operatorname{Re}(C_1) = u(x, y) + 0,$$

that C_1 is purely imaginary, so

$$f(z) = iz^3 + iC, \quad C \in \mathbb{R}.$$

Example 6.3 Check if the following functions $u(x, y)$ are harmonic:

- (a) $u(x, y) = x^2 - y^2 + y$,
- (b) $u(x, y) = x^3 - y^3$,
- (c) $u(x, y) = 3x^2y - y^3 + xy$,
- (d) $u(x, y) = x^4 - 6x^2y^2 + y^4 + x^3y - xy^3$.

If u is harmonic, then find the corresponding harmonic conjugated functions v , and $f(z) = u + iv$.

In all four cases, $u \in C^\infty(\mathbb{R}^2)$, so we shall only check if $\Delta u = 0$.

(a) Here

$$\Delta u = \frac{\partial^2 u}{\partial x^2} + \frac{\partial^2 u}{\partial y^2} = 2 - 2 = 0,$$

hence u is harmonic

1) It follows by *inspection* that

$$u(x, y) = \operatorname{Re}(z^2) - \operatorname{Re}(iz) = \operatorname{Re}(z^2 - iz),$$

so

$$v(x, y) = \operatorname{Im}(z^2 - iz) + c = 2xy - x + c, \quad c \in \mathbb{R},$$

and

$$f(z) = z^2 - iz + ic, \quad c \in \mathbb{R}.$$

2) ALTERNATIVELY it follows by *Cauchy-Riemann's equations* that

$$\begin{aligned} v(x, y) &= \int \left\{ \frac{\partial v}{\partial x} dx + \frac{\partial v}{\partial y} dy \right\} + c = \int \left\{ -\frac{\partial u}{\partial y} dx + \frac{\partial u}{\partial x} dy \right\} + c \\ &= \int \{ -(-2y + 1) dx + 2x dy \} + c = \int \{ 2(y dx + x dy) - dx \} + c \\ &= \int d(2xy - x) + c = 2xy - x + c, \quad c \in \mathbb{R}, \end{aligned}$$

and

$$\begin{aligned} f(z) &= u(x, y) + iv(x, y) = x^2 - y^2 + y + i(2xy - x + c) \\ &= x^2 - y^2 + 2ixy - i(x + iy) + ic = z^2 - iz + ic, \quad c \in \mathbb{R}. \end{aligned}$$

(b) Since $\Delta u = 6x - 6y \neq 0$ for $y \neq x$, we conclude that $u(x, y)$ is not harmonic.

(c) Here,

$$\Delta u = 6y - 6y = 0,$$

hence $u(x, y)$ is *harmonic*.

1) *Inspection*. Since $3x^2y - y^3$ is a polynomial of third degree, and xy is a polynomial of second degree in (x, y) , it is reasonable to check z^3 and z^2 . Thus

$$z^3 = (x + iy)^3 = x^3 + 3ix^2y - 3xy^2 - iy^3 = (x^3 - 3xy^2) + i(3x^2y - y^3),$$

and

$$z^2 = (x + iy)^2 = x^2 - y^2 + i \cdot 2xy.$$

It follows immediately that

$$3x^2y - y^3 = \operatorname{Re}(-iz^3) \quad \text{and} \quad xy = \operatorname{Re}\left(-\frac{i}{2}z^2\right),$$

so

$$u(x, y) = \operatorname{Re}\left(-iz^3 - \frac{i}{2}z^2\right),$$

and we conclude that

$$v(x, y) = \operatorname{Im}\left(-iz^3 - \frac{i}{2}z^2\right) + c = -\operatorname{Re}\left(z^2 + \frac{1}{2}z^2\right) + c = -x^3 + 3xy^2 - \frac{1}{2}x^2 + \frac{1}{2}y^2 + c,$$

and

$$f(z) = -iz^3 - \frac{i}{2}z^2 + ic, \quad c \in \mathbb{R}.$$

2) ALTERNATIVELY we conclude from *Cauchy-Riemann's equations* that

$$\begin{aligned}
 v(x, y) &= c + \int \left\{ -\frac{\partial u}{\partial y} dx + \frac{\partial u}{\partial x} dy \right\} = c + \int \{ -(3x^2 - 3y^2 + x) dx + (6xy + y) dy \} \\
 &= c + \int \{ -3x^2 dx + 3y^2 dx - x dx + 6xy dy + y dy \} \\
 &= c + \int \left\{ d(-x^3) + \{ 3y^2 dx + 3x d(y^2) \} - \frac{1}{2} d(x^2) + \frac{1}{2} d(y^2) \right\} \\
 &= c + \int d \left(-x^3 + 3y^2 x - \frac{1}{2} x^2 + \frac{1}{2} y^2 \right) \\
 &= -x^3 + 3y^2 x - \frac{1}{2} x^2 + \frac{1}{2} y^2 + c, \quad c \in \mathbb{R},
 \end{aligned}$$

and

$$\begin{aligned}
 f(z) &= u + iv = 3x^2 y - y^3 + xy + i \left\{ -x^3 + 3y^2 x - \frac{1}{2} x^2 + \frac{1}{2} y^2 + c \right\} \\
 &= -i \{ x^3 + 3x^2(iy) + 3x(iy)^2 + (iy)^3 \} - \frac{i}{2} \{ x^2 - y^2 + 2ixy \} + ic \\
 &= -iz^3 - \frac{i}{2} z^2 + ic, \quad c \in \mathbb{R}.
 \end{aligned}$$



What do you want to do?

No matter what you want out of your future career, an employer with a broad range of operations in a load of countries will always be the ticket. Working within the Volvo Group means more than 100,000 friends and colleagues in more than 185 countries all over the world. We offer graduates great career opportunities – check out the Career section at our web site www.volvogroup.com. We look forward to getting to know you!

VOLVO
 AB Volvo (publ)
www.volvogroup.com

VOLVO TRUCKS | RENAULT TRUCKS | MACK TRUCKS | VOLVO BUSES | VOLVO CONSTRUCTION EQUIPMENT | VOLVO PENTA | VOLVO AERO | VOLVO IT
 VOLVO FINANCIAL SERVICES | VOLVO 3P | VOLVO POWERTRAIN | VOLVO PARTS | VOLVO TECHNOLOGY | VOLVO LOGISTICS | BUSINESS AREA ASIA



(d) Here,

$$\Delta u = 12x^2 - 12y^2 + 6xy - 12x^2 + 12y^2 - 6xy = 0,$$

and $u(x, y)$ is harmonic.

1) *Inspection.* All terms of $u(x, y)$ are of fourth degree in (x, y) , so let us check z^4 . We get

$$\begin{aligned} z^4 &= (x + iy)^4 = x^4 + 4ix^3y - 6x^2y^2 - 4ixy^3 + y^4 \\ &= (x^4 - 6x^2y^2 + y^4) + 4i(x^3y - xy^3), \end{aligned}$$

so we conclude that

$$x^4 - 6x^2y^2 + y^4 = \operatorname{Re}(z^4) \quad \text{and} \quad x^3y - xy^3 = \operatorname{Re}\left(-\frac{i}{4}z^4\right),$$

hence

$$u(x, y) = \operatorname{Re}\left\{\left(1 - \frac{i}{4}\right)z^4\right\},$$

and the harmonic conjugated functions are

$$\begin{aligned} v(x, y) &= \operatorname{Im}\left\{\left(1 - \frac{i}{4}\right)z^4\right\} + c = 4x^3y - 4xy^3 - \frac{1}{4}(x^4 - 6x^2y^2 + y^4) + c \\ &= -\frac{1}{4}x^4 + 4x^3y + \frac{3}{2}x^2y^2 - 4xy^3 - \frac{1}{4}y^4 + c, \quad c \in \mathbb{R}, \end{aligned}$$

and finally,

$$f(z) = \left(1 - \frac{i}{4}\right)z^4 + ic, \quad c \in \mathbb{R}.$$

2) ALTERNATIVELY, it follows from *Cauchy-Riemann's equations* that

$$\begin{aligned} v(x, y) &= c + \int \left\{-\frac{\partial u}{\partial y} dx + \frac{\partial u}{\partial x} dy\right\} \\ &= c + \int \left\{-(-12x^2y + 4y^3 + x^3 - 3xy^2) dx + (4x^3 - 12xy^2 + 3x^2y - y^3) dy\right\} \\ &= c + \int \left\{12x^2y dx - 4y^3 dx - x^3 dx + 3xy^2 dx\right\} + 4x^3 dy - 12xy^2 dy + 3x^2y dy - y^3 dy \\ &= c + \int \left\{(4y d(x^3) + 4x^3 dy) - (4y^3 dx + 4x d(y^3))\right. \\ &\quad \left. - \frac{1}{4} d(x^2) + \frac{3}{2} (y^2 d(x^2) + x^2 d(y^2)) - \frac{1}{4} d(y^4)\right\} \\ &= c + \int d\left(4x^3y - 4xy^3 - \frac{1}{4}x^4 + \frac{3}{2}x^2y^2 - \frac{1}{4}y^4\right) \\ &= -\frac{1}{4}x^4 + 4x^3y + \frac{3}{2}x^2y^2 - 4xy^3 - \frac{1}{4}y^4 + c, \quad c \in \mathbb{R}. \end{aligned}$$

Finally,

$$\begin{aligned} f(z) &= u + iv = x^4 + 4ix^3y - 6x^2y^2 - 4ixy^3 + y^4 - \frac{i}{4}\{x^4 + 4ix^3y - 6x^2y^2 - 4ixy^3 + y^4\} + ic \\ &= z^4 - \frac{i}{4}z^4 + ic = \left(1 - \frac{i}{4}\right)z^4 + ic, \quad c \in \mathbb{R}. \end{aligned}$$

ALTERNATIVELY we get by *Cauchy-Riemann's equations* that

$$\begin{aligned}
 f'(z) &= \frac{\partial u}{\partial x} + i \frac{\partial v}{\partial x} = \frac{\partial u}{\partial x} - i \frac{\partial u}{\partial y} \\
 &= 4x^3 - 12xy^2 + 3x^2y - y^3 - i \{-12x^2y + 4y^3 + x^3 - 3xy^2\} \\
 &= 4x^3 - 12xy^2 + 3x^2y - y^3 + 12ix^2y - 4iy^3 - ix^3 + 3ixy^2 \\
 &= 4\{x^3 - 3xy^2 + 3ix^2y - iy^3\} - i\{x^3 - 3xy^2 + 3ix^2y - iy^3\} \\
 &= 4z^3 - iz^3 = (4-i)z^3.
 \end{aligned}$$

By integration,

$$f(z) = \frac{1}{4}(4-i)z^4 + a.$$

Since $u(x, y) = \operatorname{Re}(f(z))$ does not contain any constant term, a must be purely imaginary, so

$$f(z) = \left(1 - \frac{i}{4}\right)z^4 + ic, \quad c \in \mathbb{C}.$$

Example 6.4 Find an harmonic conjugated v of each of the following harmonic functions, and then find $f(z) = u + iv$:

$$(a) \ u(x, y) = x^3 - 3xy^2 + 1, \quad (b) \ u(x, y) = e^x \sin y,$$

$$(c) \ u(x, y) = x e^x \cos y - y e^x \sin y.$$

(a1) It follows by an *inspection* that

$$z^3 + 1 = x^3 - 3xy^2 + 1 + i(3x^2y - y^3) = u + iv,$$

so we may e.g. choose $v(x, y) = 3x^2y - y^3$, because we shall only indicate one harmonic conjugated. This gives $f(z) = z^3 + 1$.

(a2) ALTERNATIVELY we use *Cauchy-Riemann's equations* and line integrals:

$$\begin{aligned}
 v(x, y) &= \int \left\{ -\frac{\partial u}{\partial y} dx + \frac{\partial u}{\partial x} dy \right\} = \int \{6xy dx + (3x^2 - 3y^2) dy\} \\
 &= \int \{(6xy dx + 3x^2 dy) - 3y^2 dy\} = \int d(3x^2y - y^3) = 3x^2y - y^3,
 \end{aligned}$$

so

$$f(z) = u + iv = x^3 - 3xy^2 + 1 + i(3x^2y - y^3) = z^3 + 1.$$

(b1) It follows by *inspection* that

$$-i e^z = -i e^x (\cos y + i \sin y) = e^x \sin y - i e^x \cos y = u + iv,$$

hence

$$v(x, y) = -e^x \cos y \quad \text{and} \quad f(z) = -i e^z.$$

(b2) ALTERNATIVELY we get as above by using *Cauchy-Riemann's equations*,

$$\begin{aligned} v(x, y) &= \int \left\{ -\frac{\partial u}{\partial y} dx + \frac{\partial u}{\partial x} dy \right\} = \int \{-e^x \cos y dx + e^x \sin y dy\} \\ &= - \int \{\cos y d(e^x) + e^x d(\cos y)\} = - \int d(e^x \cos y) = -e^x \cos y, \end{aligned}$$

and

$$f(z) = u + iv = e^x \sin y - i e^x \cos y = -i(e^x \cos y + i e^x \sin y) = -i e^z.$$

(c1) It follows by *inspection* that

$$u(x, y) = x e^x \cos y - y e^x \sin y = \operatorname{Re} \{(x + iy)(e^x \cos y + i e^x \sin y)\} = \operatorname{Re}(z e^z),$$

hence

$$v(x, y) = \operatorname{Im}(z e^z) = x e^x \sin y + y e^x \cos y,$$

and

$$f(z) = z e^z.$$

(c2) ALTERNATIVELY, by *Cauchy-Riemann's equations*,

$$\begin{aligned} v(x, y) &= \int \left\{ -\frac{\partial u}{\partial y} dx + \frac{\partial u}{\partial x} dy \right\} \\ &= \int \{(x e^x \sin y + e^x \sin y + y e^x \cos y) dx + (e^x \cos y + x e^x \cos y - y e^x \sin y) dy\} \\ &= \int \{(1+x)e^x \sin y dx + y e^x \cos y dx + x e^x \cos y dy + e^x(1 \cdot \cos y - y \cdot \sin y) dy\} \\ &= \int \{\sin y d(x e^x) + y \cos y d(e^x) + x e^x d(\sin y) + e^x d(y \cos y)\} \\ &= \int \{d(x e^x \sin y) + d(e^x y \cos y)\} = x e^x \sin y + y e^x \cos y, \end{aligned}$$

and finally,

$$\begin{aligned} f(z) &= u + iv = x e^x \cos y - y e^x \sin y + i x e^x \sin y + i y e^x \cos y \\ &= x e^x \{\cos y + i \sin y\} + y e^x \{-\sin y + i \cos y\} = x e^x e^{iy} + y e^x \{i \cos y + i^2 \sin y\} \\ &= x e^z + y e^x \cdot i e^{iy} = x e^z + i y e^z = (x + iy)e^z = z e^z. \end{aligned}$$

Example 6.5 In each of the following cases one shall find a corresponding analytic function $f(z) = u + iv$, where either the real part u or the imaginary part v is given as an harmonic function:

- (a) $u(x, y) = x^2 - y^2 + 5x + y - \frac{y}{x^2 + y^2}$, $z \in \mathbb{C} \setminus \{0\}$,
 (b) $v(x, y) = \ln(x^2 + y^2) + x - 2y$, $z \in \mathbb{C} \setminus (\mathbb{R}_- \cup \{0\})$.

(a) It follows from

$$x^2 - y^2 = \operatorname{Re}(z^2), \quad 5x = \operatorname{Re}(5z), \quad y = \operatorname{Re}(-iz), \quad -\frac{y}{x^2 + y^2} = \operatorname{Re}\left(-\frac{i}{z}\right),$$

that

$$u(x, y) = \operatorname{Re}\left(z^2 + 5z - iz - \frac{i}{z}\right),$$

so we conclude that

$$f(z) = z^2 + 5z - iz - \frac{i}{z} + ic, \quad c \in \mathbb{R}, \quad z \in \mathbb{C} \setminus \{0\}.$$

gaiTEYE[®]
Challenge the way we run

**EXPERIENCE THE POWER OF
FULL ENGAGEMENT...**

**RUN FASTER.
RUN LONGER..
RUN EASIER...**

**READ MORE & PRE-ORDER TODAY
WWW.GAITEYE.COM**

(b) It follows from

$$\operatorname{Im}(2i \operatorname{Log} z) = \ln(x^2 + y^2), \quad \operatorname{Im}(-iz) = x, \quad \operatorname{Im}(-2z) = -2y,$$

that

$$v(x, y) = \operatorname{Im}(2i \operatorname{Log} z + iz - 2z),$$

and we conclude that

$$f(z) = 2i \operatorname{Log} z + iz - 2z + c, \quad c \in \mathbb{R}, \quad z \in \mathbb{C} \setminus (\mathbb{R}_- \cup \{0\}).$$

Example 6.6 Prove that the function

$$\varphi(x, y) = 2 - x + \frac{x}{x^2 + y^2}, \quad (x, y) \neq (0, 0),$$

is harmonic.

Find the harmonic conjugated function $\psi(x, y)$, for which $\psi(1, 0) = 2$, and then describe

$$f(z) = \varphi(x, y) + i\psi(x, y)$$

as a function of z .

Then put $z = e^w$. By this change of variable one shall find $\Phi(u, v) = \varphi(x, y)$, and the value of $\Phi(u, v)$ on the line $u = 0$.

(a1) It follows by inspection that

$$\varphi(x, y) = 2 - \operatorname{Re}(z) + \operatorname{Re}\left(\frac{1}{z}\right) = \operatorname{Re}\left(2 - z + \frac{1}{z}\right).$$

Since $2 + \frac{1}{z} - z$ is analytic for $z \neq 0$, the function $\varphi(x, y)$ is harmonic as the real part of an analytic function.

(a2) ALTERNATIVELY we check if the *Cauchy-Riemann equations* are fulfilled. We get by differentiating

$$\frac{\partial \varphi}{\partial x} = -1 + \frac{y^2 - x^2}{(x^2 + y^2)^2}, \quad \frac{\partial \varphi}{\partial y} = -\frac{2xy}{(x^2 + y^2)^2},$$

and

$$\frac{\partial^2 \varphi}{\partial x^2} = -\frac{2x}{(x^2 + y^2)^2} - 2 \cdot \frac{2x(y^2 - x^2)}{(x^2 + y^2)^3} = -2 \frac{x^3 + 3xy^2 - 2x^3}{(x^2 + y^2)^3} = 2 \frac{x^3 - 3xy^2}{(x^2 + y^2)^3},$$

$$\frac{\partial^2 \varphi}{\partial y^2} = -\frac{2x}{(x^2 + y^2)^2} + 2 \cdot \frac{2y \cdot 2xy}{(x^2 + y^2)^3} = -2 \frac{x^3 + xy^2 - 4xy^2}{(x^2 + y^2)^3} = -2 \frac{x^3 - 3xy^2}{(x^2 + y^2)^3},$$

hence

$$\Delta \varphi = \frac{\partial^2 \varphi}{\partial x^2} + \frac{\partial^2 \varphi}{\partial y^2} = 0,$$

and it follows that $\varphi(x, y)$ is harmonic.

(b1) Using the expression of (a1) we get

$$\psi(x, y) = \operatorname{Im} \left(2 - z + \frac{1}{z} \right) + c = -y - \frac{y}{x^2 + y^2} + c,$$

so we conclude from $\psi(1, 0) = 2$ that $c = 2$, hence

$$\psi(x, y) = -y - \frac{y}{x^2 + y^2} + 2.$$

(b2) ALTERNATIVELY, by *Cauchy-Riemann's equations* for $(x, y) \in \mathbb{R}^2 \setminus \{(\mathbb{R}_- \cup \{0\}) \times \{0\}\}$,

$$\begin{aligned} \psi(x, y) &= 2 + \int_{(1,0)}^{(x,y)} \left\{ -\frac{\partial \varphi}{\partial y} dx + \frac{\partial \varphi}{\partial x} dy \right\} \\ &= 2 + \int_{(1,0)}^{(x,y)} \left\{ \frac{2xy}{(x^2 + y^2)^2} dx + \left(-1 + \frac{y^2 - x^2}{(x^2 + y^2)^2} \right) dy \right\} \\ &= 2 + \int_1^x \frac{2ty}{(t^2 + y^2)^2} dt + \int_0^y \left\{ -1 + \frac{t^2 - 1}{(1 + t^2)^2} \right\} dt \\ &= 2 - \left[\frac{y}{t^2 + y^2} \right]_{t=1}^x - y + \int_0^y \left\{ \frac{1}{(1 + t^2)^2} \right\} dt. \end{aligned}$$

Now

$$\begin{aligned} \int \frac{1}{1+t^2}, dt &= \frac{t}{1+t^2} + \int \frac{t \cdot 2t}{(1+t^2)^2} dt = \frac{t}{t^2+1} + 2 \int \frac{t^2+1-1}{(1+t^2)^2} dt \\ &= \frac{t}{1+t^2} + 2 \int \frac{1}{1+t^2} dt - 2 \int \frac{1}{(1+t^2)^2} dt, \end{aligned}$$

so

$$\int_0^y \left\{ \frac{1}{1+t^2} - \frac{2}{(1+t^2)^2} \right\} dt = \left[-\frac{t}{t^2+1} \right]_0^y = -\frac{y}{y^2+1},$$

and we get by insertion that

$$\psi(x, y) = 2 - y - \frac{y}{y^2+1} - \frac{y}{x^2+y^2} + \frac{y}{y^2+1} = 2 - y - \frac{y}{x^2+y^2}.$$

Finally,

$$f(z) = \varphi(x, y) + i\psi(x, y) = 2 - x + \frac{x}{x^2 + y^2} + 2i - iy - \frac{iy}{x^2 + y^2} = 2 + 2i - z + \frac{1}{z}.$$

(c) If $z = e^w$, then

$$g(w) = f(z) = 2 + 2i - e^w + e^{-w} = 2 + 2i - 2 \sinh w,$$

hence

$$\Phi(u, v) = 2 - 2 \operatorname{Re}(\sinh w) = 2 - 2 \sinh u \cdot \cos v.$$

If $u = 0$, then

$$\Phi(0, v) = 2.$$

Example 6.7 Assume that $f = u + iv$ is analytic in an open domain Ω . Prove that uv is harmonic in Ω .

Then check, when the function u^2 is also harmonic.

Let u and v be any C^2 -functions. Then

$$\frac{\partial}{\partial x}(uv) = v \frac{\partial u}{\partial x} + u \frac{\partial v}{\partial x},$$

and

$$\frac{\partial^2}{\partial x^2}(uv) = v \frac{\partial^2 u}{\partial x^2} + u \frac{\partial^2 v}{\partial x^2} + 2 \frac{\partial u}{\partial x} \cdot \frac{\partial v}{\partial x},$$

and analogously,

$$\frac{\partial^2}{\partial y^2}(uv) = v \frac{\partial^2 u}{\partial y^2} + u \frac{\partial^2 v}{\partial y^2} + 2 \frac{\partial u}{\partial y} \cdot \frac{\partial v}{\partial y}.$$

Finally, by an addition,

$$(2) \quad \Delta(uv) = v \cdot \Delta u + u \cdot \Delta v + 2 \left\{ \frac{\partial u}{\partial x} \cdot \frac{\partial v}{\partial x} + \frac{\partial u}{\partial y} \cdot \frac{\partial v}{\partial y} \right\}.$$

We now assume that $f = u + iv$ is analytic. Then $\Delta u = 0$ and $\Delta v = 0$, and we have by *Cauchy-Riemann's equations* that

$$\frac{\partial u}{\partial x} = \frac{\partial v}{\partial y} \quad \text{and} \quad \frac{\partial u}{\partial y} = -\frac{\partial v}{\partial x},$$

and (2) is reduced to

$$\Delta(uv) = 0 + 0 + 2 \left\{ \frac{\partial u}{\partial x} \left(-\frac{\partial u}{\partial y} \right) + \frac{\partial u}{\partial y} \cdot \frac{\partial u}{\partial x} \right\} = 0,$$

proving that uv is harmonic.

Then assume that u is harmonic, $\Delta u = 0$. If we choose $v = u$ in (2), then

$$\Delta(u^2) = 0 + 0 + 2 \left\{ \left(\frac{\partial u}{\partial x} \right)^2 + \left(\frac{\partial u}{\partial y} \right)^2 \right\} = 2 |\mathbf{grad} u|^2.$$

This expression is 0, if and only if $\mathbf{grad} u = 0$, thus if and only if u is a constant.

Example 6.8 Assume that $\varphi(x, y)$ is of class C^2 . Prove that the family of curves

$$\varphi(x, y) = k, \quad k \in \mathbb{R},$$

can be considered as a family of level curves for some harmonic function, if and only if

$$\frac{\Delta\varphi}{|\text{grad } \varphi|^2}$$

only depends on φ and not of any derivative of φ .

HINT: First prove that the wanted harmonic function must be of the form $u = f(\varphi(x, y))$.

It is obvious that if $\varphi(x, y) = k$ defines a family of level curves for some harmonic function u , then there exists some function f , such that

$$u(x, y) = f(k),$$

and we can write

$$u(x, y) = f(\varphi(x, y)).$$

This e-book
is made with
SetaPDF

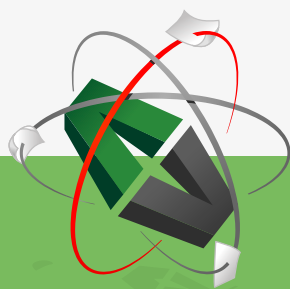

PDF components for PHP developers

www.setasign.com



Click on the ad to read more

Then we find

$$\frac{\partial u}{\partial x} = f'(\varphi) \frac{\partial \varphi}{\partial x}, \quad \frac{\partial^2 u}{\partial x^2} = f''(\varphi) \cdot \left\{ \frac{\partial \varphi}{\partial x} \right\}^2 + f'(\varphi) \cdot \frac{\partial^2 \varphi}{\partial x^2},$$

and analogously,

$$\frac{\partial^2 u}{\partial y^2} = f''(\varphi) \left\{ \frac{\partial \varphi}{\partial y} \right\}^2 + f'(\varphi) \cdot \frac{\partial^2 \varphi}{\partial y^2}.$$

Since $f \circ \varphi = u$ is harmonic, we must have

$$0 = f''(\varphi) \left\{ \left(\frac{\partial \varphi}{\partial x} \right)^2 + \left(\frac{\partial \varphi}{\partial y} \right)^2 \right\} + f'(\varphi) \left\{ \frac{\partial^2 \varphi}{\partial x^2} + \frac{\partial^2 \varphi}{\partial y^2} \right\} = f''(\varphi) \cdot |\mathbf{grad} \varphi|^2 + f'(\varphi) \Delta \varphi.$$

Thus, if $\mathbf{grad} \varphi \neq \mathbf{0}$, and $f'(\varphi) \neq 0$, then

$$\frac{\Delta \varphi}{|\mathbf{grad} \varphi|^2} = -\frac{f''(\varphi)}{f'(\varphi)},$$

and the claim follows.

On the other hand, if

$$\frac{\Delta \varphi}{|\mathbf{grad} \varphi|^2}$$

only depends on φ , then we define

$$f'(\varphi) = \exp \left(- \int \frac{\Delta \varphi}{|\mathbf{grad} \varphi|^2} d\varphi \right),$$

so we conclude that

$$f''(\varphi) = -\frac{\Delta \varphi}{|\mathbf{grad} \varphi|^2} \cdot f'(\varphi),$$

hence $f \circ \varphi = u$ is harmonic.

Example 6.9 Assume that $u(x, y)$ is an harmonic function. Find all real functions $f : \mathbb{R} \rightarrow \mathbb{R}$, for which the composite function $f(u(x, y))$ is harmonic.

If u is a constant, then any $f : \mathbb{R} \rightarrow \mathbb{R}$ can be used.

If $\mathbf{grad} u \neq \mathbf{0}$, then we at least must assume that f is of class C^2 . We get under this assumption that

$$\frac{\partial}{\partial x} (f \circ u) = (f' \circ u) \frac{\partial u}{\partial x},$$

and

$$\frac{\partial^2}{\partial x^2} (f \circ u) = (f'' \circ u) \left(\frac{\partial u}{\partial x} \right)^2 + (f' \circ u) \frac{\partial^2 u}{\partial x^2},$$

and analogously,

$$\frac{\partial^2}{\partial y^2}(f \circ u) = (f' \circ u) \left(\frac{\partial u}{\partial y} \right)^2 + (f'' \circ u) \frac{\partial^2 u}{\partial y^2},$$

thus

$$\Delta(f \circ u) = (f'' \circ u) \left\{ \left(\frac{\partial u}{\partial x} \right)^2 + \left(\frac{\partial u}{\partial y} \right)^2 \right\} + (f' \circ u) \Delta u = (f'' \circ u) |\mathbf{grad} u|^2.$$

Since $|\mathbf{grad} u| \neq 0$, it follows that $f \circ u$ is harmonic, if and only if $f'' \circ u = 0$, thus $f''(t) = 0$, and

$$f(t) = At + B, \quad \text{where } A, B \in \mathbb{R}.$$

If u is not a constant, then $|\mathbf{grad} u| \neq 0$ almost everywhere, so we conclude that $f(t) = At + B$ almost everywhere. Since f is continuous, we finally get

$$f(t) = At + B, \quad t \in \mathbb{R}.$$

Example 6.10 Find all real functions $\varphi : \mathbb{R} \rightarrow \mathbb{R}$ of class C^2 of the real variable t , such that the following functions u become harmonic.

$$(a) \ u(x, y) = \varphi(x), \quad (b) \ u(x, y) = \varphi(ax + by), \quad a, b \in \mathbb{R}.$$

First variant. Since $x = \operatorname{Re}(z)$ and $ax + by = \operatorname{Re}\{(a - ib)z\}$ are harmonic, it follows from Example 6.9 that

$$\varphi(t) = At + B, \quad A, B \in \mathbb{R}.$$

Second variant. If one does not know the result of Example 6.9, then we proceed as follows:

(a) If $u(x, y) = \varphi(x)$, then

$$\frac{\partial^2 u}{\partial x^2} = \varphi''(x) \quad \text{and} \quad \frac{\partial^2 u}{\partial y^2} = 0.$$

Hence we get the condition

$$0 = \Delta u = \frac{\partial^2 u}{\partial x^2} + \frac{\partial^2 u}{\partial y^2} = \varphi''(x),$$

thus

$$\varphi(t) = At + B, \quad A, B \in \mathbb{R}.$$

(b) If $u(x, y) = \varphi(ax + by)$, then put $t = ax + by$. By differentiation,

$$\frac{\partial^2 u}{\partial x^2} = a^2 \varphi''(t) \quad \text{and} \quad \frac{\partial^2 u}{\partial y^2} = b^2 \varphi''(t),$$

hence by insertion into the Laplace equation,

$$0 = \Delta u = \frac{\partial^2 u}{\partial x^2} + \frac{\partial^2 u}{\partial y^2} = (a^2 + b^2) \varphi''(t).$$

If $(a, b) = (0, 0)$, then $u = \text{constant}$ (and thus harmonic) for every φ .

If $(a, b) \neq (0, 0)$, then $\varphi''(t) = 0$, and hence

$$\varphi(t) = At + B, \quad A, B \in \mathbb{R}.$$

Remark 6.1 We see that **(a)** corresponds to $(a, b) = (1, 0)$ in **(b)**. \diamond

Example 6.11 Find all the real functions $\varphi : \mathbb{R} \rightarrow \mathbb{R}$ of class C^2 in the real variable t such that the following functions u become harmonic.

$$(a) \ u(x, y) = \varphi(x^2 - y^2), \quad (b) \ u(x, y) = \varphi(xy).$$

First variant. Since

$$x^2 - y^2 = \operatorname{Re}(z^2) \quad \text{and} \quad xy = \frac{1}{2} \operatorname{Im}(z^2)$$

are harmonic and not constant, it follows from Example 6.9, that the only possibilities are

$$\varphi(t) = At + B, \quad A, B \in \mathbb{R}.$$

Second variant. ALTERNATIVELY just compute:

(a) If $u(x, y) = \varphi(x^2 - y^2)$, then

$$\frac{\partial u}{\partial x} = 2x \cdot \varphi'(x^2 - y^2), \quad \frac{\partial^2 u}{\partial x^2} = 4x^2 \varphi''(x^2 - y^2) + 2\varphi'(x^2 - y^2),$$

$$\frac{\partial u}{\partial y} = -2y \cdot \varphi'(x^2 - y^2), \quad \frac{\partial^2 u}{\partial y^2} = 4y^2 \varphi''(x^2 - y^2) - 2\varphi'(x^2 - y^2),$$

hence

$$0 = \Delta u = \frac{\partial^2 u}{\partial x^2} + \frac{\partial^2 u}{\partial y^2} = 4(x^2 + y^2) \varphi''(x^2 - y^2) = 0,$$

and we have derived the condition $\varphi''(t) = 0$ for $(x, y) \neq (0, 0)$, hence

$$\varphi(t) = At + B, \quad A, B \in \mathbb{R}, \quad t \in \mathbb{R},$$

because $(x, y) \neq (0, 0)$ does not give any real constraint on $t \in \mathbb{R}$.

(b) If $u(x, y) = \varphi(xy)$, then

$$0 = \Delta u = \frac{\partial^2 u}{\partial x^2} + \frac{\partial^2 u}{\partial y^2} = y^2 \varphi''(xy) + x^2 \varphi''(xy) = (x^2 + y^2) \varphi''(xy).$$

If we put $t = xy$, then $\varphi''(t) = 0$, hence by two integrations,

$$\varphi(t) = At + B, \quad A, B \in \mathbb{R}.$$

Example 6.12 Find all the real functions $\varphi : \mathbb{R} \rightarrow \mathbb{R}$ of class C^2 in the real variable t , such that the following functions u become harmonic.

$$(a) \ u(x, y) = \varphi\left(\frac{y}{x}\right), \quad x \neq 0, \quad (b) \ u(x, y) = \varphi\left(\frac{x^2 + y^2}{x}\right), \quad x \neq 0,$$

In this example none of the functions

$$\frac{y}{x}, \quad \frac{x^2 + y^2}{x},$$

are harmonic, so we cannot use Example 6.9. One could, however, use Example 6.8 instead. This is left to the reader as an exercise.

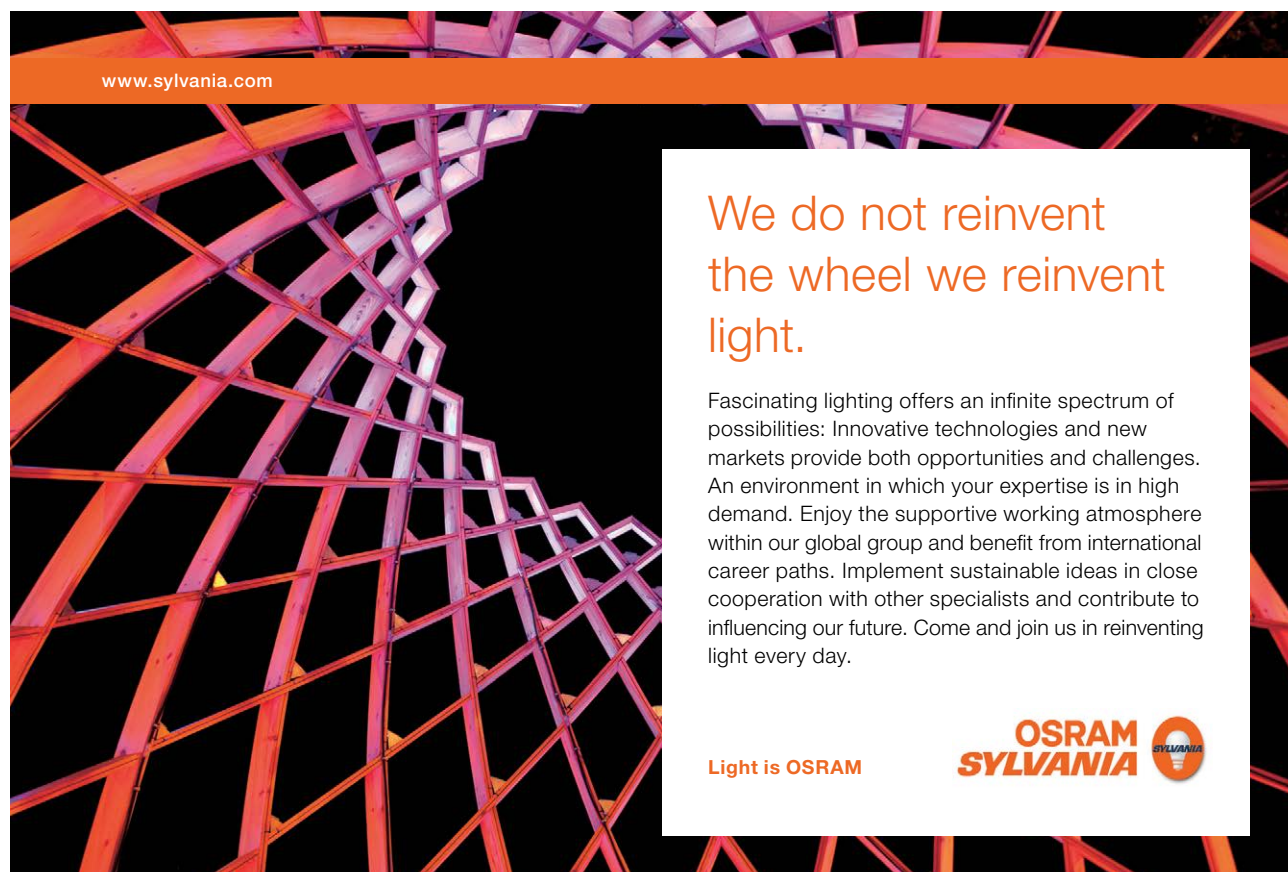

www.sylvania.com

We do not reinvent
the wheel we reinvent
light.

Fascinating lighting offers an infinite spectrum of possibilities: Innovative technologies and new markets provide both opportunities and challenges. An environment in which your expertise is in high demand. Enjoy the supportive working atmosphere within our global group and benefit from international career paths. Implement sustainable ideas in close cooperation with other specialists and contribute to influencing our future. Come and join us in reinventing light every day.

Light is OSRAM

OSRAM
SYLVANIA

(a) If $u(x, y) = \varphi\left(\frac{y}{x}\right)$, then we get for $x \neq 0$,

$$\frac{\partial u}{\partial x} = -\frac{y}{x^2} \varphi'\left(\frac{y}{x}\right), \quad \frac{\partial^2 u}{\partial x^2} = \frac{y^2}{x^4} \varphi''\left(\frac{y}{x}\right) + \frac{2y}{x^3} \varphi'\left(\frac{y}{x}\right),$$

$$\frac{\partial u}{\partial y} = \frac{1}{x} \varphi'\left(\frac{y}{x}\right), \quad \frac{\partial^2 u}{\partial y^2} = \frac{1}{x^2} \varphi''\left(\frac{y}{x}\right),$$

and the constraint becomes

$$0 = \Delta u = \frac{\partial^2 u}{\partial x^2} + \frac{\partial^2 u}{\partial y^2} = \frac{x^2 + y^2}{x^4} \varphi''\left(\frac{y}{x}\right) + \frac{2y}{x^2} \varphi'\left(\frac{y}{x}\right).$$

By a multiplication by x^2 we get the equivalent equation

$$\left\{1 + \left(\frac{y}{x}\right)^2\right\} \varphi''\left(\frac{y}{x}\right) + 2\frac{y}{x} \cdot \varphi'\left(\frac{y}{x}\right) = 0.$$

Then put $t = \frac{y}{x}$ in order to derive the differential equation

$$0 = (1 + t^2) \varphi''(t) + 2t \varphi'(t) = \frac{d}{dt} \{(1 + t^2) \varphi'(t)\},$$

from which we get by integration,

$$(1 + t^2) \varphi'(t) = A, \quad \text{thus} \quad \varphi'(t) = \frac{A}{1 + t^2}.$$

Then by another integration,

$$\varphi(t) = A \cdot \text{Arctan } t + B, \quad A, B \in \mathbb{R}.$$

Hence, the corresponding harmonic functions are

$$u(x, y) = A \cdot \text{Arctan}\left(\frac{y}{x}\right) + B, \quad A, B \in \mathbb{R}.$$

(b) If

$$u(x, y) = \varphi\left(\frac{x^2 + y^2}{x}\right), \quad x \neq 0,$$

then it follows by differentiation,

$$\frac{\partial u}{\partial x} = \frac{2x^2 - x^2 - y^2}{x^2} \varphi'\left(\frac{x^2 + y^2}{x}\right) = \frac{x^2 - y^2}{x^2} \varphi'\left(\frac{x^2 + y^2}{x}\right),$$

$$\frac{\partial^2 u}{\partial x^2} = \left(\frac{x^2 - y^2}{x^2}\right)^2 \varphi''\left(\frac{x^2 + y^2}{x}\right) + 2\frac{y^2}{x^3} \varphi' - \left(\frac{x^2 + y^2}{x}\right),$$

$$\frac{\partial u}{\partial y} = 2\frac{y}{x} \varphi'\left(\frac{x^2 + y^2}{x}\right),$$

$$\frac{\partial^2 u}{\partial y^2} = 4\frac{y^2}{x^2} \varphi''\left(\frac{x^2 + y^2}{x}\right) + 2\frac{1}{x} \varphi'\left(\frac{x^2 + y^2}{x}\right).$$

Hence we obtain the condition

$$\begin{aligned} 0 &= \Delta u = \frac{\partial^2 u}{\partial x^2} + \frac{\partial^2 u}{\partial y^2} \\ &= \frac{(x^2 - y^2)^2 + 4x^2 y^2}{x^4} \varphi'' \left(\frac{x^2 + y^2}{x} \right) + 2 \frac{x^2 + y^2}{x^3} \varphi' \left(\frac{x^2 + y^2}{x} \right) \\ &= \frac{1}{x^2} \left\{ \left(\frac{x^2 + y^2}{x} \right)^2 \varphi'' \left(\frac{x^2 + y^2}{x} \right) + 2 \frac{x^2 + y^2}{x} \varphi' \left(\frac{x^2 + y^2}{x} \right) \right\}. \end{aligned}$$

When this equation is multiplied by $x^2 (\neq 0)$, and we put $t = \frac{x^2 + y^2}{x} \neq 0$, then we get the differential equation

$$0 = t^2 \varphi''(t) + 2t \varphi'(t) = \frac{d}{dt} \{t^2 \varphi'(t)\},$$

hence by an integration,

$$t^2 \varphi'(t) = -A, \quad \text{thus} \quad \varphi'(t) = -\frac{A}{t^2}.$$

Finally, by another integration,

$$\varphi(t) = \frac{A}{t} + B, \quad A, B \in \mathbb{R}.$$

The corresponding harmonic functions are not given by

$$u(x, y) = A \cdot \frac{x}{x^2 + y^2} + B, \quad A, B \in \mathbb{R},$$

where we according to the proof must assume that $x \neq 0$. However, by making a small check it is easy to see that it is enough to require that $(x, y) \neq (0, 0)$.

Remark 6.2 We could have solved the problem easier, if we had noted that

$$\frac{x^2 + y^2}{x} = \left(\frac{x}{x^2 + y^2} \right)^{-1}, \quad \text{for } x \neq 0,$$

and then applied that

$$\frac{x}{x^2 + y^2}, \quad (x, y) \neq (0, 0),$$

is harmonic. Then it follows from Example 6.9 that all the corresponding harmonic functions are given by $\varphi(t) = At + B$, thus

$$u(x, y) = A \frac{x}{x^2 + y^2} + B, \quad A, B \in \mathbb{R}, \quad (x, y) \neq (0, 0).$$

Notice that this latently contains a rather sophisticated argument, so I have not classified it as an alternative solution. (It is too difficult.) \diamond

Example 6.13 Find all the real functions $\varphi : \mathbb{R}_+ \rightarrow \mathbb{R}$ of class C^2 in the real variable t , for which the following functions u are harmonic.

$$(a) \quad u(x, y) = \varphi(x^2 + y^2), \quad (x, y) \neq (0, 0),$$

$$(b) \quad u(x, y) = \varphi\left(x + \sqrt{x^2 + y^2}\right), \quad (x, y) \neq (0, 0).$$

It is not possible either here to apply Example 6.9. It is, however, possible to use Example 6.8 instead. This is left to the reader.

(a) If $u(x, y) = \varphi(x^2 + y^2)$, $x^2 + y^2 \neq 0$, is harmonic, then

$$\frac{\partial u}{\partial x} = 2x \varphi'(x^2 + y^2), \quad \frac{\partial^2 u}{\partial x^2} = 4x^2 \varphi''(x^2 + y^2) + 2 \varphi'(x^2 + y^2),$$

$$\frac{\partial u}{\partial y} = 2y \varphi'(x^2 + y^2), \quad \frac{\partial^2 u}{\partial y^2} = 4y^2 \varphi''(x^2 + y^2) + 2 \varphi'(x^2 + y^2),$$

and the condition becomes

$$\Delta u = \frac{\partial^2 u}{\partial x^2} + \frac{\partial^2 u}{\partial y^2} = 4(x^2 + y^2) \varphi''(x^2 + y^2) + 4 \varphi'(x^2 + y^2) = 0.$$

If we put $t = x^2 + y^2 (> 0)$, this equation if reduced to

$$0 = t \varphi''(t) + \varphi'(t) = \frac{d}{dt} \{t \varphi'(t)\}, \quad t > 0,$$

hence by an integration,

$$t \cdot \varphi'(t) = A, \quad t > 0, \quad \text{thus} \quad \varphi'(t) = \frac{A}{t}, \quad t > 0.$$

We get by another integration,

$$\varphi(t) = A \cdot \ln t + B, \quad A, B \in \mathbb{R}, \quad t > 0.$$

The corresponding harmonic functions are then given by

$$u(x, y) = A \cdot \ln(x^2 + y^2) + B, \quad A, B \in \mathbb{R}, \quad (x, y) \neq (0, 0).$$

(b) If

$$u(x, y) = \varphi\left(x + \sqrt{x^2 + y^2}\right), \quad (x, y) \neq (0, 0),$$

then $x + \sqrt{x^2 + y^2} = t > 0$, and we get

$$\begin{aligned} \frac{\partial u}{\partial x} &= \left(1 + \frac{x}{\sqrt{x^2 + y^2}}\right) \varphi' \left(x + \sqrt{x^2 + y^2}\right), \\ \frac{\partial^2 u}{\partial x^2} &= \left(1 + \frac{x}{\sqrt{x^2 + y^2}}\right)^2 \varphi'' \left(x + \sqrt{x^2 + y^2}\right) \\ &\quad + \left(\frac{1}{\sqrt{x^2 + y^2}} - \frac{x^2}{(\sqrt{x^2 + y^2})^3}\right) \varphi' \left(x + \sqrt{x^2 + y^2}\right) \\ &= \frac{(x + \sqrt{x^2 + y^2})^2}{x^2 + y^2} \varphi'' \left(x + \sqrt{x^2 + y^2}\right) + \frac{y^2}{(x^2 + y^2) \sqrt{x^2 + y^2}} \varphi' \left(x + \sqrt{x^2 + y^2}\right), \\ \frac{\partial u}{\partial y} &= \frac{y}{\sqrt{x^2 + y^2}} \varphi' \left(x + \sqrt{x^2 + y^2}\right), \\ \frac{\partial^2 u}{\partial y^2} &= \frac{y^2}{x^2 + y^2} \varphi'' \left(x + \sqrt{x^2 + y^2}\right) \\ &\quad + \left(\frac{1}{\sqrt{x^2 + y^2}} - \frac{y^2}{(\sqrt{x^2 + y^2})^3}\right) \varphi' \left(x + \sqrt{x^2 + y^2}\right) \\ &= \frac{y^2}{x^2 + y^2} \varphi'' \left(x + \sqrt{x^2 + y^2}\right) + \frac{x^2}{(x^2 + y^2) \sqrt{x^2 + y^2}} \varphi' \left(x + \sqrt{x^2 + y^2}\right). \end{aligned}$$



Discover the truth at www.deloitte.ca/careers

Deloitte.

© Deloitte & Touche LLP and affiliated entities.



We end up with the condition

$$\begin{aligned}
 0 &= \Delta u = \frac{\partial^2 u}{\partial x^2} + \frac{\partial^2 u}{\partial y^2} \\
 &= \frac{x^2 + x^2 + y^2 + 2x\sqrt{x^2 + y^2} + y^2}{x^2 + y^2} \varphi''(x + \sqrt{x^2 + y^2}) \\
 &\quad + \frac{x^2 + y^2}{(\sqrt{x^2 + y^2})^3} \varphi'(x + \sqrt{x^2 + y^2}) \\
 &= 2 \frac{x^2 + y^2 + x\sqrt{x^2 + y^2}}{(\sqrt{x^2 + y^2})^2} \varphi''(x + \sqrt{x^2 + y^2}) + \frac{1}{\sqrt{x^2 + y^2}} \varphi'(x + \sqrt{x^2 + y^2}) \\
 &= \frac{1}{\sqrt{x^2 + y^2}} \left\{ 2(x + \sqrt{x^2 + y^2}) + \varphi'(x + \sqrt{x^2 + y^2}) \right\}.
 \end{aligned}$$

Now put $t = x + \sqrt{x^2 + y^2} > 0$. Then we multiply by $\sqrt{x^2 + y^2} \neq 0$ in order to obtain the following equivalent differential equation of first order in $\varphi'(t)$,

$$2t \varphi''(t) + \varphi'(t) = 0.$$

The complete solution is

$$\varphi'(t) = \frac{\tilde{A}}{\sqrt{t}},$$

hence by an integration and another arbitrary constant A ,

$$\varphi(t) = A\sqrt{t} + B, \quad A, B \in \mathbb{R}, \quad t \in \mathbb{R}_+.$$

The corresponding harmonic functions are

$$u(x, y) = A\sqrt{x + \sqrt{x^2 + y^2}} + B, \quad A, B \in \mathbb{R}, \quad (x, y) \neq (0, 0).$$

Example 6.14 Prove the existence of, and find the analytic functions $f(z) = \varrho e^{i\varphi}$, when ϱ is given by

$$(a) \varrho = (x^2 + y^2) e^x, \quad (b) \varrho = \exp(r^2 \cos 2\theta).$$

Here, $z = x + iy = r e^{i\theta}$.

(a1) It follows by *inspection* that

$$\varrho = r^2 e^x = |z|^2 |e^z| = |z^2 e^z|,$$

hence

$$f(z) = c z^2 e^z, \quad \text{where } |c| = 1.$$

(a2) ALTERNATIVELY we use *Cauchy-Riemann's equations in polar coordinates*. First note that we have in polar coordinates,

$$f(z) = \varrho e^{i\varphi} = \varrho \cos \varphi + i \varrho \sin \varphi,$$

hence by separation into real and imaginary part,

$$u = r^2 e^{r \cos \theta} \cdot \cos \varphi(r, \theta), \quad v = r^2 e^{r \cos \theta} \cdot \sin \varphi(r, \theta).$$

Thus

$$\begin{aligned} \frac{\partial u}{\partial r} &= 2r e^{r \cos \theta} \cos \varphi + r^2 \cos \theta e^{r \cos \theta} \cdot \cos \varphi - r^2 e^{r \cos \theta} \sin \varphi \cdot \frac{\partial \varphi}{\partial r} \\ &= r e^{r \cos \theta} \left\{ \cos \varphi \cdot (2 + r \cos \theta) - r \sin \varphi \cdot \frac{\partial \varphi}{\partial r} \right\}, \\ \frac{1}{r} \frac{\partial v}{\partial \theta} &= \frac{1}{r} \left\{ r^2 \cdot r(-\sin \theta) e^{r \cos \theta} \sin \varphi + r^2 e^{r \cos \theta} \cos \varphi \cdot \frac{\partial \varphi}{\partial \theta} \right\} \\ &= r e^{r \cos \theta} \cos \varphi \cdot \frac{\partial \varphi}{\partial \theta} - r^2 \sin \theta e^{r \cos \theta} \sin \varphi \\ &= r e^{r \cos \theta} \left\{ \cos \varphi \cdot \frac{\partial \varphi}{\partial \theta} - r \sin \varphi \cdot \sin \theta \right\}. \end{aligned}$$

We shall now use the following one of Cauchy-Riemann's equations,

$$\frac{\partial u}{\partial r} = \frac{1}{r} \frac{\partial v}{\partial \theta}.$$

It follows from the above that

$$(3) (\cos \varphi, \sin \varphi) \cdot \left(2 + r \cos \theta, -r \frac{\partial \varphi}{\partial r} \right) = (\cos \varphi, \sin \varphi) \cdot \left(\frac{\partial \varphi}{\partial \theta}, -r \sin \theta \right),$$

which is fulfilled when

$$(4) \frac{\partial \varphi}{\partial \theta} = 2 + r \cos \theta, \quad \frac{\partial \varphi}{\partial r} = \sin \theta,$$

hence for

$$\varphi(r, \theta) = 2\theta + r \cdot \sin \theta + k, \quad k \in \mathbb{R}.$$

Then by insertion,

$$\begin{aligned} f(z) &= \varrho e^{i\varphi} = (x^2 + y^2) e^x e^{i(2\theta + r \sin \theta + k)} = r^2 e^{2i\theta} \cdot e^x e^{iy} e^{ik} = (r e^{i\theta})^2 e^{x+iy} e^{ik} \\ &= e^{ik} \cdot z^2 e^z, \end{aligned}$$

which of course is an analytic function.

When we use the other one of Cauchy-Riemann's equations in polar coordinates we conclude that (4) is the only relevant solution of (3)

(b1) It follows by *inspection* that

$$\varrho = \exp(\operatorname{Re}(z^2)) = |\exp(z^2)|,$$

hence

$$f(z) = C \cdot \exp(z^2), \quad \text{where } |C| = 1.$$

(b2) ALTERNATIVELY we use *Cauchy-Riemann's equations in polar coordinates*. We first see that

$$u = \exp(r^2 \cos 2\theta) \cos \varphi(r, \theta) \quad \text{and} \quad v = \exp(r^2 \cos 2\theta) \sin \varphi(r, \theta),$$

hence by differentiation,

$$\begin{aligned} \frac{\partial u}{\partial r} &= 2r \cos 2\theta \cdot \exp(r^2 \cos 2\theta) \cos \varphi - \exp(r^2 \cos 2\theta) \sin \varphi \cdot \frac{\partial \varphi}{\partial r} \\ &= \exp(r^2 \cos 2\theta) (\cos \varphi, \sin \varphi) \cdot \left(2r \cos 2\theta, -\frac{\partial \varphi}{\partial r} \right), \\ \frac{1}{r} \frac{\partial v}{\partial \theta} &= \frac{1}{r} \left\{ -2r^2 \sin 2\theta \cdot \sin \varphi + \cos \varphi \cdot \frac{\partial \varphi}{\partial \theta} \right\} \exp(r^2 \cos 2\theta) \\ &= \exp(r^2 \cos 2\theta) \cdot (\cos \varphi, \sin \varphi) \cdot \left(\frac{1}{r} \frac{\partial \varphi}{\partial \theta}, -2r \sin 2\theta \right). \end{aligned}$$

Then we apply the following one of Cauchy-Riemann's equations,

$$\frac{\partial u}{\partial r} = \frac{1}{r} \frac{\partial v}{\partial \theta}.$$

Note, however, that in the first place the implication is going in the wrong direction. However, by using the other one of Cauchy-Riemann's equations it actually follows that it is legal to use this formula. We get

$$\frac{1}{r} \frac{\partial \varphi}{\partial \theta} = 2r \cos 2\theta \quad \text{and} \quad \frac{\partial \varphi}{\partial r} = 2r \sin 2\theta,$$

hence

$$\frac{\partial \varphi}{\partial \theta} = 2r^2 \cos 2\theta \quad \text{and} \quad \frac{\partial \varphi}{\partial r} = 2r \sin 2\theta,$$

so

$$\varphi(r, \theta) = r^2 \sin 2\theta + k, \quad k \in \mathbb{R}.$$

Finally, by insertion

$$f(z) = \varrho e^{i\varphi} = \exp(r^2 \cos 2\theta) \exp(i(r^2 \sin 2\theta + k)) = e^{ik} \exp(r^2 e^{2i\theta}) = e^{ik} \exp(z^2),$$

which of course is analytic.

Example 6.15 Prove the existence of and find the analytic functions $f(z) = \rho e^{i\varphi}$, when φ is given by

$$(a) \varphi = xy, \quad (b) \varphi = \theta + r \sin \theta.$$

Here, $z = x + iy = r e^{i\theta}$.

(a1) It follows by *inspection* that

$$e^{i\varphi} = e^{ixy} = \exp\left(\frac{1}{2}(2ixy)\right),$$

so we guess on

$$f(z) = C \cdot \exp\left(\frac{1}{2}z^2\right), \quad C \in \mathbb{R}_+,$$

which is easily seen to be a solution.

SIMPLY CLEVER

ŠKODA



We will turn your CV into
an opportunity of a lifetime



Do you like cars? Would you like to be a part of a successful brand?
We will appreciate and reward both your enthusiasm and talent.
Send us your CV. You will be surprised where it can take you.

Send us your CV on
www.employerforlife.com



Click on the ad to read more

(a2) ALTERNATIVELY we apply *Cauchy-Riemann's equations* to find ϱ . We first identify

$$u = \varrho \cdot \cos(xy) \quad \text{and} \quad v = \varrho \cdot \sin(xy),$$

and then get by a differentiation,

$$\frac{\partial u}{\partial x} = \frac{\partial \varrho}{\partial x} \cos(xy) - y \cdot \varrho \sin(xy) = (\cos(xy), \sin(xy)) \cdot \left(\frac{\partial \varrho}{\partial x}, -y \varrho \right),$$

$$\frac{\partial v}{\partial y} = x \cdot \varrho \cos(xy) + \frac{\partial \varrho}{\partial y} \sin(xy) = (\cos(xy), \sin(xy)) \cdot \left(x \varrho, \frac{\partial \varrho}{\partial y} \right).$$

Thus

$$\frac{\partial \varrho}{\partial x} = x \cdot \varrho \quad \text{og} \quad \frac{\partial \varrho}{\partial y} = -y \varrho,$$

and hence

$$\frac{1}{\varrho} \frac{\partial \varrho}{\partial x} = x \quad \text{og} \quad \frac{1}{\varrho} \frac{\partial \varrho}{\partial y} = -y,$$

so

$$\ln \varrho = \frac{1}{2} x^2 + C_1(y) = -\frac{1}{2} y^2 + C_2(x),$$

from which

$$\ln \varrho = \frac{1}{2} (x^2 - y^2) + k, \quad \text{eller } \varrho = C \cdot \exp\left(\frac{1}{2} (x^2 - y^2)\right).$$

Finally, by insertion,

$$f(z) = C \cdot \exp\left(\frac{1}{2} (x^2 - y^2)\right) e^{i xy} = C \cdot \exp\left(\frac{1}{2} z^2\right), \quad C \in \mathbb{R}_+,$$

which clearly is analytic.

(b1) If $\varphi = \theta + r \cdot \sin \theta$, then

$$u = \varrho(r, \theta) \cos(\theta + r \sin \theta), \quad v = \varrho(r, \theta) \sin(\theta + r \sin \theta),$$

hence

$$\frac{\partial u}{\partial r} = \frac{\partial \varrho}{\partial r} \cos \varphi - \varrho \sin \varphi \cdot \sin \theta = (\cos \varphi, \sin \varphi) \cdot \left(\frac{\partial \varrho}{\partial r}, -\varrho \sin \theta \right),$$

$$\frac{1}{r} \frac{\partial v}{\partial \theta} = \frac{1}{r} \frac{\partial \varrho}{\partial \theta} \sin \varphi + \frac{1}{r} \varrho \cos \varphi \cdot \{1 + r \cos \theta\} = (\cos \varphi, \sin \varphi) \cdot \left(\varrho \left\{ \frac{1}{r} + \cos \theta \right\}, \frac{1}{r} \frac{\partial \varrho}{\partial \theta} \right).$$

Since $\frac{\partial u}{\partial r} = \frac{1}{r} \frac{\partial v}{\partial \theta}$, a solution must satisfy the following equation

$$\frac{1}{r} \frac{\partial \varrho}{\partial \theta} = -\varrho \sin \theta, \quad \text{and} \quad \frac{\partial \varrho}{\partial r} = \frac{1}{2} \varrho \cdot \{1 + r \cos \theta\},$$

thus by a rearrangement,

$$\frac{1}{\varrho} \frac{\partial \varrho}{\partial \theta} = -r \sin \theta, \quad \text{and} \quad \frac{1}{\varrho} \frac{\partial \varrho}{\partial r} = \frac{1}{r} + \cos \theta.$$

By analyzing the second one of Cauchy-Riemann's equations we conclude that this is the only possibility.

Then by an integration,

$$\ln \varrho = r \cdot \cos \theta + C_1(r) = r \cdot \cos \theta + \ln r + C_2(\theta),$$

and we conclude that

$$\ln \varrho = \ln r + r \cdot \cos \theta + k, \quad k \in \mathbb{R},$$

which we write as

$$\varrho = C r e^{r \cos \theta}, \quad C \in \mathbb{R}_+.$$

Finally, by insertion,

$$\begin{aligned} f(z) &= \varrho e^{i\varphi} = C \cdot r e^{r \cos \theta} e^{i(\theta + r \sin \theta)} \\ &= C r e^{i\theta} e^{x+iy} = C z e^z, \quad C \in \mathbb{R}_+, \end{aligned}$$

which clearly is analytic.

(b2) ALTERNATIVELY it follows by *inspection* that

$$e^{i\varphi} = e^{i\theta + i r \sin \theta} = e^{i\theta} e^{iy},$$

so our guess is

$$f(z) = C \cdot r e^{i\theta} \cdot e^x \cdot e^{iy} = C z e^z, \quad C \in \mathbb{R}_+.$$

Example 6.16 (a) Prove that the function

$$\varphi(x, y) = x \ln \sqrt{x^2 + y^2} - y \operatorname{Arctan} \frac{y}{x}, \quad x \in \mathbb{R}_+, \quad y \in \mathbb{R},$$

is harmonic.

(b) Denote by $\psi(x, y)$ the harmonic conjugated function of $\varphi(x, y)$, for which $\psi(1, 0) = 0$, and denote by $f(z) = \varphi(x, y) + i\psi(x, y)$ the corresponding analytic function. Find

$$f'(z) = \frac{\partial \varphi}{\partial x} + i \frac{\partial \psi}{\partial x}$$

as a function of z . Then express $f(z)$ in the variable z .

Inspection. First note that we have for $x > 0$,

$$\operatorname{Log} z = \ln |z| + i\theta = \ln \sqrt{x^2 + y^2} + i \operatorname{Arctan} \frac{y}{x}.$$

Then it follows by *inspection*,

$$\begin{aligned} \varphi(x, y) &= x \cdot \ln \sqrt{x^2 + y^2} - y \cdot \operatorname{Arctan} \frac{y}{x} \\ &= \operatorname{Re} \left((x + iy) \left(\ln \sqrt{x^2 + y^2} + i \operatorname{Arctan} \frac{y}{x} \right) \right) = \operatorname{Re}(z \operatorname{Log} z). \end{aligned}$$

The function $z \operatorname{Log} z$ is in the open right half plane the product of two analytic functions, so it is also analytic, and $\varphi(x, y)$ is *harmonic* because it is the real part of an analytic function.

Since

$$\operatorname{Im}(z \operatorname{Log} z) = x \cdot \theta + y \ln |z| = x \cdot \operatorname{Arctan} \frac{y}{x} + y \ln \sqrt{x^2 + y^2}$$

is an harmonic conjugated of φ , and since this function is 0 for $(x, y) = (1, 0)$, we conclude that

$$\psi(x, y) = x \cdot \operatorname{Arctan} \frac{y}{x} + y \sqrt{x^2 + y^2}, \quad x \in \mathbb{R}_+, \quad y \in \mathbb{R},$$

and

$$f(z) = \varphi(x, y) + i\psi(x, y) = z \operatorname{Log} z, \quad \operatorname{Re}(z) > 0.$$

Finally, by a differentiation,

$$f'(z) = 1 + \operatorname{Log} z, \quad \operatorname{Re}(z) > 0.$$

Standard method.

(a) Since φ is composed of infinitely often differentiable functions in the given domain, φ is also infinitely often differentiable. Then write

$$\varphi(x, y) = x \cdot \ln \sqrt{x^2 + y^2} - y \cdot \operatorname{Arctan} \frac{y}{x} = \frac{1}{2} x \cdot \ln (x^2 + y^2) - y \cdot \operatorname{Arctan} \frac{y}{x},$$

and we get by a differentiation that

$$\begin{aligned}\frac{\partial \varphi}{\partial x} &= \frac{1}{2} \ln(x^2 + y^2) + \frac{1}{2} x \cdot \frac{2x}{x^2 + y^2} - y \cdot \frac{1}{1 + \left(\frac{y}{x}\right)^2} \cdot \left(-\frac{y}{x^2}\right) \\ &= \frac{1}{2} \ln(x^2 + y^2) + \frac{x^2}{x^2 + y^2} + \frac{y^2}{x^2 + y^2} = \frac{1}{2} \ln(x^2 + y^2) + 1,\end{aligned}$$

$$\frac{\partial^2 \varphi}{\partial x^2} = \frac{x}{x^2 + y^2},$$

$$\begin{aligned}\frac{\partial \varphi}{\partial y} &= \frac{1}{2} x \cdot \frac{2y}{x^2 + y^2} - \operatorname{Arctan} \frac{y}{x} - y \cdot \frac{1}{1 + \left(\frac{y}{x}\right)^2} \cdot \frac{1}{x} \\ &= \frac{xy}{x^2 + y^2} - \operatorname{Arctan} \frac{y}{x} - \frac{yx}{x^2 + y^2} = -\operatorname{Arctan} \frac{y}{x},\end{aligned}$$

$$\frac{\partial^2 \varphi}{\partial y^2} = -\frac{1}{1 + \left(\frac{y}{x}\right)^2} \cdot \frac{1}{x} = -\frac{x}{x^2 + y^2}.$$

I joined MITAS because
I wanted **real responsibility**

The Graduate Programme
for Engineers and Geoscientists
www.discovermitas.com



Month 16

I was a construction
supervisor in
the North Sea
advising and
helping foremen
solve problems

Real work
International opportunities
Three work placements



 **MAERSK**



It follows that

$$\Delta\varphi = \frac{\partial^2\varphi}{\partial x^2} + \frac{\partial^2\varphi}{\partial y^2} = \frac{x}{x^2+y^2} - \frac{x}{x^2+y^2} = 0,$$

and we have proved that φ is *harmonic*.

Remark 6.3 One is never requested to compute the function ψ . If we do it, we get the following variant:

We choose the path of integration as the broken line

$$(1, 0) \longrightarrow (x, 0) \longrightarrow (x, y).$$

Then by taking some simple primitives,

$$\begin{aligned} \psi(x, y) &= \int \left\{ -\frac{\partial\varphi}{\partial y} dx + \frac{\partial\varphi}{\partial x} dy \right\} + \text{constant} \\ &= \int \left\{ +\operatorname{Arctan} \frac{y}{x} dx + \left\{ \frac{1}{2} \ln(x^2 + y^2) + 1 \right\} dy \right\} + \text{constant} \\ &= \psi(1, 0) + \int_1^x \operatorname{Arctan} \left(\frac{0}{t} \right) dt + \int_0^y \left\{ \frac{1}{2} \ln(x^2 + t^2) + 1 \right\} dt \\ &= y + \int_0^y \frac{1}{2} \ln(x^2 + t^2) dt \\ &= y + \left[\frac{1}{2} t \cdot \ln(x^2 + t^2) - \int \frac{1}{2} t \cdot \frac{2t}{x^2 + t^2} dt \right]_0^y \\ &= y + \frac{1}{2} y \cdot \ln(x^2 + y^2) - \int_0^y \frac{t^2 + (x^2 - x^2)}{x^2 + t^2} dt \\ &= y + \frac{1}{2} y \cdot \ln(x^2 + y^2) - \int_0^y \left\{ 1 - \frac{x^2}{x^2 + t^2} \right\} dt \\ &= y + \frac{1}{2} y \cdot \ln(x^2 + y^2) - y + \int_0^y \frac{1}{1 + \left(\frac{t}{x}\right)^2} dt \\ &= \frac{1}{2} y \ln(x^2 + y^2) + x \cdot \operatorname{Arctan} \frac{y}{x} \\ &= y \ln \sqrt{x^2 + y^2} + x \cdot \operatorname{Arctan} \frac{y}{x}. \end{aligned}$$

Thus

$$\begin{aligned} f(z) &= \varphi(x, y) + i\psi(x, y) \\ &= x \ln \sqrt{x^2 + y^2} - y \operatorname{Arctan} \frac{y}{x} + iy \ln \sqrt{x^2 + y^2} + ix \operatorname{Arctan} \frac{y}{x} \\ &= (x + iy) \ln \sqrt{x^2 + y^2} + i(x + iy) \operatorname{Arctan} \frac{y}{x} \\ &= (x + iy) \left(\ln \sqrt{x^2 + y^2} + i \operatorname{Arctan} \frac{y}{x} \right) = z \operatorname{Log} z, \end{aligned}$$

and hence

$$f'(z) = 1 + \operatorname{Log} z. \quad \diamond$$

(b) By *Cauchy-Riemann's equations* we get

$$\begin{aligned} f'(z) &= \frac{\partial\varphi}{\partial x} + i \frac{\partial\psi}{\partial x} = \frac{\partial\varphi}{\partial x} - i \frac{\partial\varphi}{\partial y} = \frac{1}{2} \ln(x^2 + y^2) + 1 + i \operatorname{Arctan} \frac{y}{x} \\ &= 1 + \left\{ \ln \sqrt{x^2 + y^2} + i \operatorname{Arctan} \frac{y}{x} \right\} = 1 + \operatorname{Log} z. \end{aligned}$$

In particular, $f'(x) = 1 + \ln x$ on the positive real half axis, so we get for $x \in \mathbb{R}_+$ that

$$f(x) = \int_1^x \{1 + \ln t\} dt = \left[t + t \cdot \ln t - \int \frac{t}{t} dt \right]_1^x = [t \cdot \ln t]_1^x = x \cdot \ln x.$$

Since $z \cdot \operatorname{Log} z$ is an analytic function in the right half plane, which is equal to $x \cdot \ln x$ on the positive real half axis, we conclude by the uniqueness theorem of analytic functions that

$$f(z) = z \cdot \operatorname{Log} z, \quad \text{for } \operatorname{Re}(z) > 0.$$

Example 6.17 Prove that the function

$$\varphi(x, y) = \operatorname{Arccot} \left(\frac{x-y}{x+y} \right), \quad x+y > 0,$$

is harmonic.

Find the harmonic conjugated function $\psi(x, y)$ of $\varphi(x, y)$, for which $\psi(1, 0) = 0$, and then write $f(z) = \varphi(x, y) + i\psi(x, y)$ as a function in z , e.g. by first finding $f'(z)$.

Consider $f(z)$ as a complex potential in the domain $x + y > 0$. sketch the streamlines and the equipotential curves corresponding to $f(z)$ in this domain.

Inspection. Note that we shall not follow the questions of the example strictly by this method, if only we answer all of them. First analyze Arccot .

Put $w = u + iv$, $v > 0$. Let $\operatorname{Arg} w$ denote the *principal* argument of w . Then the function

$$\operatorname{Arg} w = \operatorname{Arccot} \frac{u}{v} \quad (= \operatorname{Im}(\operatorname{Log} w)),$$

is harmonic in the two variables u and v . Since

$$\varphi(x, y) = \operatorname{Arccot} \left(\frac{x-y}{x+y} \right),$$

is is very *tempting* to choose

$$u = x - y \quad \text{og} \quad v = x + y,$$

i.e.

$$w = x - y + i(x + y) = x + iy + i(x + iy) = (1 + i)z.$$

Now, $w = (1 + i)z$ is *analytic* (and *conformal*) in z , and since $\operatorname{Arg} w$ is *harmonic* in u and v , it follows that

$$\varphi(x, y) = \operatorname{Arccot} \left(\frac{x-y}{x+y} \right) = \operatorname{Arg}\{(1 + i)z\}, \quad x + y > 0,$$

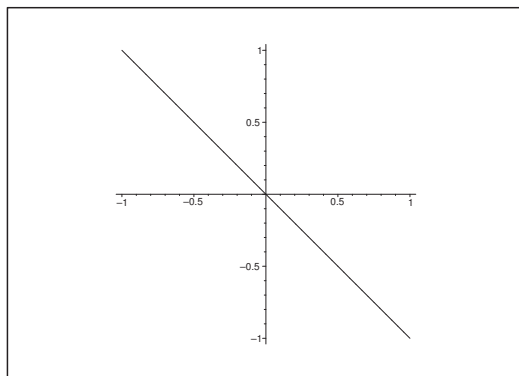

Figure 14: The open domain Ω lies above the oblique line $y = -x$.

is harmonic.

Then note that the domain $x + y > 0$ is given in polar coordinates by

$$r > 0, \quad -\frac{\pi}{4} < \theta < \frac{3\pi}{4}.$$

Then the domain can shortly be described by

$$-\frac{\pi}{4} < \text{Arg } z < \frac{3\pi}{4},$$

because the *principal* argument of any complex number $\neq 0$ lies in $] -\pi, \pi]$. Since the principal argument only fix a *direction*, i.e. a half line from 0, and since

$$1 + i = \sqrt{2} \exp\left(i \frac{\pi}{4}\right),$$

it follows that

$$\varphi(x, y) = \text{Arg}((1 + i)z) = \text{Arg}\left(\sqrt{2} \exp\left(i \frac{\pi}{4}\right) z\right) = \text{Arg}\left(\left(\exp\left(i \frac{\pi}{4}\right) \cdot z\right)\right) = \frac{\pi}{4} + \text{Arg } z,$$

because multiplication by $\exp\left(i \frac{\pi}{4}\right)$ corresponds to a rotation of $\frac{\pi}{4}$.

Remark 6.4 We see that $\frac{\pi}{4} + \text{Arg } z \in]0, \pi[$, i.e. the image of the principal argument, when z lies in the domain given by $x + y > 0$. \diamond

We conclude from

$$\text{Log } w = \ln |w| + i \text{Arg } w, \quad w \neq 0,$$

that

$$-i \text{Log } w = \text{Arg } w - i \ln |w|,$$

thus for $x + y > 0$,

$$\varphi(x, y) = \frac{\pi}{4} + \operatorname{Arg} z = \operatorname{Re} \left(\frac{\pi}{4} - i \operatorname{Log} z + i \cdot C \right), \quad C \in \mathbb{R}.$$

Hence, *all* harmonic conjugated functions of $\varphi(x, y)$ are given by

$$\Psi(x, y) = \operatorname{Im} \left(\frac{\pi}{4} - i \operatorname{Log} z + i \cdot C \right) = -\ln |z| + C, \quad C \in \mathbb{R}.$$

The searched harmonic conjugated function $\psi(x, y)$, $x + y > 0$, shall also fulfil the condition $\psi(1, 0) = 0$, hence by insertion,

$$\psi(1, 0) = -\ln 1 + C = C = 0,$$

thus $C = 0$, and we get

$$\psi(x, y) = -\ln |z| = -\ln \sqrt{x^2 + y^2} = -\frac{1}{2} \ln (x^2 + y^2).$$

Finally, it follows from $C = 0$ that

$$f(z) = \varphi(x, y) + i\psi(x, y) = \frac{\pi}{4} - i \operatorname{Log} z, \quad x + y > 0.$$

ie business school

#1 EUROPEAN BUSINESS SCHOOL
FINANCIAL TIMES 2013

#gobeyond

MASTER IN MANAGEMENT

Because achieving your dreams is your greatest challenge. IE Business School's Master in Management taught in English, Spanish or bilingually, trains young high performance professionals at the beginning of their career through an innovative and stimulating program that will help them reach their full potential.

- Choose your area of specialization.
- Customize your master through the different options offered.
- Global Immersion Weeks in locations such as London, Silicon Valley or Shanghai.

Because you change, we change with you.

www.ie.edu/master-management | mim.admissions@ie.edu |

In other forms of computations one may get the equivalent expressions

$$f(z) = -i \operatorname{Log}((1+i)z) + i \frac{1}{2} \ln 2 = -i \operatorname{Log} \left(\exp \left(i \frac{\pi}{4} \right) z \right).$$

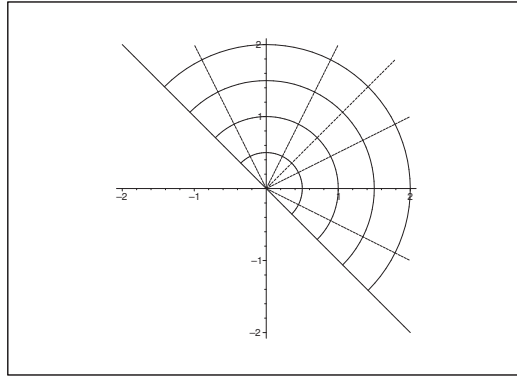

Figure 15: The streamlines are the half circles, and the equipotential curves are the half lines.

The *streamlines* are given by $\psi(x, y) = -\ln |z| = k$, thus

$$|z| = e^{-k}, \quad x + y > 0.$$

Hence, the streamlines are a family of half circles in the domain $x + y > 0$ of centrum at $z = 0$.

The *equipotential curves* are given by

$$\varphi(x, y) = \frac{\pi}{4} + \operatorname{Arg} z = k,$$

hence

$$\operatorname{Arg} z = k - \frac{\pi}{4}.$$

These curves form a family of half lines from $z = 0$ in the domain given by $x + y > 0$.

Standard method. The function

$$\varphi(x, y) = \operatorname{Arccot} \left(\frac{x-y}{x+y} \right)$$

belongs to C^∞ in the domain given by $x + y > 0$. Then by a differentiation,

$$\begin{aligned} \frac{\partial \varphi}{\partial x} &= -\frac{1}{1 + \left(\frac{x-y}{x+y} \right)^2} \cdot \frac{1 \cdot (x+y) - 1 \cdot (x-y)}{(x+y)^2} = -\frac{x+y-x+y}{(x+y)^2 + (x-y)^2} = -\frac{y}{x^2 + y^2} \\ \frac{\partial \varphi}{\partial y} &= -\frac{1}{1 + \left(\frac{x-y}{x+y} \right)^2} \cdot \frac{(-1)(x+y) - 1 \cdot (x-y)}{(x+y)^2} = -\frac{-x-y-x+y}{(x+y)^2 + (x-y)^2} = \frac{x}{x^2 + y^2}, \end{aligned}$$

and

$$\Delta\varphi = \frac{\partial^2\varphi}{\partial x^2} + \frac{\partial^2\varphi}{\partial y^2} = +\frac{2xy}{(x^2+y^2)^2} - \frac{2xy}{(x^2+y^2)^2} = 0.$$

Thus, φ fulfils the Laplace equation in the given domain, so φ is harmonic.

Write $f(z) = \varphi(x, y) + i\psi(x, y)$. Then by Cauchy-Riemann's equations,

$$\begin{aligned} f'(z) &= \frac{\partial\varphi}{\partial x} + i\frac{\partial\psi}{\partial x} = \frac{\partial\varphi}{\partial x} - i\frac{\partial\varphi}{\partial y} = -\frac{y}{x^2+y^2} - i\frac{x}{x^2+y^2} \\ &= -i \cdot \frac{x-iy}{x^2+y^2} = -i\frac{\bar{z}}{z\bar{z}} = -\frac{i}{z}. \end{aligned}$$

The principal logarithm $\text{Log } z$ is a primitive of $\frac{1}{z}$ in the domain under consideration, so

$$f(z) = -i \text{Log } z + C, \quad x + y > 0.$$

If $z = 1 = 1 + i \cdot 0$ then

$$C = f(1) = \varphi(1, 0) + i \cdot \psi(1, 0) = \text{arccot} \left(\frac{1-0}{1+0} \right) + i \cdot 0 = \frac{\pi}{4},$$

hence

$$f(z) = -i \text{Log } z + \frac{\pi}{4} = \frac{\pi}{4} + \text{Arg } z - i \ln |z|.$$

It follows immediately from the latter expression that

$$\psi(x, y) = -\ln |z| = -\ln \sqrt{x^2 + y^2} = -\ln r.$$

Finally, the streamlines and the equipotential curves are found as above.

Variante. One may also find the harmonic conjugated function ψ in the following way. Since $\psi(1, 0) = 0$, we get by line integrals,

$$\begin{aligned} \psi(x, y) &= \int_{(1,0)}^{(x,y)} \left\{ -\frac{\partial\varphi}{\partial y} dx + \frac{\partial\varphi}{\partial x} dy \right\} = \int_{(1,0)}^{(x,y)} \left\{ -\frac{x}{x^2+y^2} dx - \frac{y}{x^2+y^2} dy \right\} \\ &= -\frac{1}{2} \int_{(1,0)}^{(x,y)} \frac{1}{x^2+y^2} d(x^2+y^2) = -\frac{1}{2} \ln(x^2+y^2) = -\ln \sqrt{x^2+y^2}. \end{aligned}$$

Example 6.18 Prove that the function

$$\varphi(x, y) = x \sin x \cosh y - y \cos x \sinh y, \quad (x, y) \in \mathbb{R}^2,$$

is harmonic. Then find the harmonic conjugated function $\psi(x, y)$ of $\varphi(x, y)$, for which $\psi(\pi, 0) = 0$, and finally

$$f(z) = \varphi(x, y) + i\psi(x, y)$$

as a function of z .

First method. It follows by *inspection* from

$$z = x + iy \quad \text{and} \quad \sin z = \sin x \cdot \cosh y + i \cos x \cdot \sinh y,$$

that

$$\varphi(x, y) = x \cdot \sin x \cdot \cosh y - y \cdot \cos x \cdot \sinh y = \operatorname{Re}(z \cdot \sin z).$$

Now, $z \cdot \sin z$ is *analytic* in \mathbb{C} , so $\varphi(x, y)$ is *harmonic* in \mathbb{R}^2 , because it is the real part of an analytic function.

All harmonic conjugated functions $\psi(x, y)$ are given by

$$\psi(x, y) = \operatorname{Im}(z \cdot \sin z) + C = x \cdot \cos x \cdot \sinh y + y \cdot \sin x \cdot \cosh y + C,$$

where $C \in \mathbb{R}$ is an arbitrary constant. It follows from $\psi(\pi, 0) = 0$ that $C = 0$, hence

$$\psi(x, y) = x \cdot \cos x \cdot \sinh y + y \cdot \sin x \cdot \cosh y.$$

Finally, we conclude from the above that

$$f(z) = \varphi(x, y) + i\psi(x, y) = z \cdot \sin z.$$

Second method. ALTERNATIVELY we have $\varphi \in C^\infty(\mathbb{R}^2)$. Then by differentiation,

$$\begin{aligned} \frac{\partial \varphi}{\partial x} &= \sin x \cdot \cosh y + x \cdot \cos x \cdot \cosh y + y \cdot \sin x \cdot \sinh y, \\ \frac{\partial^2 \varphi}{\partial x^2} &= 2 \cos x \cdot \cosh y - x \cdot \sin x \cdot \cosh y + y \cdot \cos x \cdot \sinh y, \end{aligned}$$

and

$$\begin{aligned} \frac{\partial \varphi}{\partial y} &= x \cdot \sin x \cdot \sinh y - \cos x \cdot \sinh y - y \cdot \cos x \cdot \cosh y, \\ \frac{\partial^2 \varphi}{\partial y^2} &= x \cdot \sin x \cdot \cosh y - 2 \cos x \cdot \cosh y - y \cdot \cos x \cdot \sinh y, \end{aligned}$$

hence

$$\Delta \varphi = \frac{\partial^2 \varphi}{\partial x^2} + \frac{\partial^2 \varphi}{\partial y^2} = 0.$$

Thus we have proved that φ is harmonic in \mathbb{R}^2 .

The harmonic conjugated function $\psi(x, y)$ of $\varphi(x, y)$, where $\psi(\pi, 0) = 0$, is found by means of *Cauchy-Riemann's equations* and a line integral:

$$\begin{aligned}\psi(x, y) &= \int_{(\pi, 0)} \left\{ \frac{\partial \psi}{\partial x} dx + \frac{\partial \psi}{\partial y} dy \right\} = \int_{(\pi, 0)} \left\{ -\frac{\partial \varphi}{\partial y} dx + \frac{\partial \varphi}{\partial x} dy \right\} \\ &= \int_{(\pi, 0)} (-x \sin x \sinh y + \cos x \sinh y + y \cos x \cosh y) dx \\ &\quad + (\sin x \cosh y + x \cos x \cosh y + y \sin x \sinh y) dy.\end{aligned}$$

The value of this line integral can e.g. be found by an integration along a broken line:

$$(\pi, 0) \longrightarrow (x, 0) \longrightarrow (x, y).$$

Then

$$\begin{aligned}\psi(x, y) &= \int_0^y 0 dt + \int_0^y (\sin x \cosh t + x \cos x \cosh t + \sin x t \cdot \sinh t) dt \\ &= \sin x \int_0^y (1 \cdot \cosh t + t \cdot \sinh t) dt + x \cdot \cos x \cdot \sinh y \\ &= \sin x \cdot y \cdot \cosh y + x \cdot \cos x \cdot \sinh y,\end{aligned}$$



STUDY AT A TOP RANKED INTERNATIONAL BUSINESS SCHOOL

Reach your full potential at the Stockholm School of Economics, in one of the most innovative cities in the world. The School is ranked by the Financial Times as the number one business school in the Nordic and Baltic countries.

Visit us at www.hhs.se





or ALTERNATIVELY by playing a little with the well-known formula

$$d(u \cdot v) = v du + u dv,$$

so we get

$$\begin{aligned} \psi(x, y) &= \int_{(\pi, 0)} (\sinh y \cdot \{x(-\sin x) + 1 \cdot \cos x\} dx + y \cosh y d(\sin x) \\ &\quad + \sin x \cdot \{1 \cdot \cosh y + y \cdot \sinh y\} dy + x \cos x d(\sinh y)) \\ &= \int_{(\pi, 0)} \{\sinh y d(x \cos x) + y \cosh y d(\sin x) \\ &\quad + x \cos x d(\sinh y) + \sin x d(y \cosh y)\} \\ &= \int_{(\pi, 0)} d\{x \cos x \sinh y + y \sin x \cosh y\} \\ &= x \cos x \sinh y + y \sin x \cosh y. \end{aligned}$$

Finally,

$$\begin{aligned} f(z) &= \varphi(x, y) + i\psi(x, y) \\ &= x \sin x \cosh y - y \cos x \sinh y + i y \sin x \cosh y + i x \cos x \sinh y \\ &= (x + iy) \sin x \cosh y + i(x + iy) \cos x \sinh y \\ &= (x + iy) \{\sin x \cosh y + i \cos x \sinh y\} \\ &= z \cdot \sin z. \end{aligned}$$

Example 6.19 1) Prove that the function

$$\varphi(x, y) = \operatorname{Arctan} \left(\frac{y}{1+x} \right)$$

is harmonic in the domain

$$\Omega = \{z \in \mathbb{C} \mid \operatorname{Re}(z) > -1\}.$$

2) Find harmonic conjugated function $\psi(x, y)$ of $\varphi(x, y)$ in Ω , where $\psi(0, 0) = 0$.

3) Find the analytic function

$$f(z) = \varphi(x, y) + i\psi(x, y), \quad z = x + iy \in \Omega,$$

as a known function in z .

First method. *Inspection.*

1) If $w = u + iv$, where $u > 0$, then

$$\operatorname{Log} w = \operatorname{Log}(u + iv) = \frac{1}{2} \ln(u^2 + v^2) + i \operatorname{Arctan} \left(\frac{v}{u} \right),$$

hence

$$\operatorname{Arctan}\left(\frac{v}{u}\right) = \operatorname{Im}(\operatorname{Log} w).$$

Then by a comparison,

$$\frac{v}{u} = \frac{y}{1+x},$$

and it is tempting to put $u = 1 + x$ and $v = y$. Choosing these, we see that $u > 0$ for $z \in \Omega$ and

$$\operatorname{Arctan}\left(\frac{y}{1+x}\right) = \operatorname{Im}(\operatorname{Log}(1+z)) = \operatorname{Re}(-i \operatorname{Log}(1+z)), \quad z \in \Omega.$$

Now, $-i \operatorname{Log}(1+z)$ is analytic in Ω , so

$$\operatorname{Arctan}\left(\frac{y}{1+x}\right)$$

is *harmonic* in Ω (considered as a subset of \mathbb{R}^2).

2) All harmonic conjugated functions ψ in Ω are given by

$$\begin{aligned} \psi(x, y) &= c + \operatorname{Im}(-i \operatorname{Log}(1+z)) = x - \operatorname{Re}(\operatorname{Log} w) \\ &= c - \frac{1}{2} \ln(u^2 + v^2) = c - \frac{1}{2} \ln((1+x)^2 + y^2), \end{aligned}$$

where $c \in \mathbb{R}$ is a real constant. Then it follows from $\psi(0, 0) = 0$ that

$$c = \psi(0, 0) + \frac{1}{2} \ln((1+0)^2 + 0^2) = 0 + 0 = 0,$$

hence

$$\psi(x, y) = -\frac{1}{2} \ln(1+x)^2 + y^2).$$

3) Finally, we obtain from the above,

$$\begin{aligned} f(z) &= \varphi(x, y) + i\psi(x, y) = \operatorname{Re}(-i \operatorname{Log}(1+z)) + i \operatorname{Im}(-i \operatorname{Log}(1+z)) \\ &= -i \operatorname{Log}(1+z). \end{aligned}$$

Second method. *Definition of an harmonic function.*

1) Clearly,

$$\varphi(x, y) = \operatorname{Arctan}\left(\frac{y}{1+x}\right)$$

belongs to $C^\infty(\Omega)$. Then by differentiation,

$$\frac{\partial \varphi}{\partial x} = \frac{1}{1 + \left(\frac{y}{1+x}\right)^2} \cdot \left(-\frac{y}{(1+x)^2}\right) = -\frac{y}{(1+x)^2 + y^2},$$

$$\frac{\partial \varphi}{\partial y} = \frac{1}{1 + \left(\frac{y}{1+x}\right)^2} \cdot \frac{1}{1+x} = \frac{1+x}{(1+x)^2 + y^2},$$

so

$$\frac{\partial^2 \varphi}{\partial x^2} = \frac{2(1+x)y}{((1+x)^2 + y^2)^2} \quad \text{og} \quad \frac{\partial^2 \varphi}{\partial y^2} = -\frac{2y(1+x)}{((1+x)^2 + y^2)^2},$$

and it follows that $\Delta \varphi = 0$ in Ω , so φ is harmonic in Ω .

2) The harmonic conjugated $\psi(x, y)$ is defined by the line integral

$$\begin{aligned} \psi(x, y) &= \psi(0, 0) + \int_{(0,0)}^{(x,y)} \left\{ -\frac{\partial \varphi}{\partial y} dx + \frac{\partial \varphi}{\partial x} dy \right\} \\ &= \int_{(0,0)}^{(x,y)} \left\{ -\frac{1+x}{(1+x)^2 + y^2} dx - \frac{y}{(1+x)^2 + y^2} dy \right\} \\ &= -\frac{1}{2} \int_{(0,0)}^{(x,y)} \frac{d\{(1+x)^2 + y^2\}}{(1+x)^2 + y^2} \\ &= -\frac{1}{2} \ln \{(1+x)^2 + y^2\}. \end{aligned}$$



#1
in eco-friendly
attitude

**STUDY AT
LINKÖPING UNIVERSITY, SWEDEN**
RANKED AMONG TOP 50 UNIVERSITIES UNDER 50

Interested in Strategy and Management in International Organisations? Kick-start your career with a master's degree from Linköping University, Sweden.

→ **Click here!**

 **Linköping University**

3) A direct computation gives

$$\begin{aligned}
 f(z) &= \varphi(x, y) + i\psi(x, y) \\
 &= \operatorname{Arctan}\left(\frac{y}{x+1}\right) - i\frac{1}{2} \ln((1+x)^2 + y^2) \\
 &= -i\{\ln|1+x+iy| + i\operatorname{Arg}(1+x+iy)\} \\
 &= -i\{\ln|1+z| + i\operatorname{Arg}(1+z)\} \\
 &= -i\operatorname{Log}(1+z).
 \end{aligned}$$

ALTERNATIVELY we have for $z \in \Omega$,

$$\begin{aligned}
 f'(z) &= \frac{\partial\varphi}{\partial x} - i\frac{\partial\varphi}{\partial y} = -\frac{y}{(1+x)^2 + y^2} - i\frac{1+x}{(1+x)^2 + y^2} \\
 &= -i\frac{1+x-iy}{(1+x+iy)(1+x-iy)} = -i\frac{1}{1+x+iy} \\
 &= -i \cdot \frac{1}{1+z},
 \end{aligned}$$

hence by finding a primitive,

$$f(z) = c - i\operatorname{Log}(1+z),$$

where

$$c = f(0) + i\operatorname{Log}(1+0) = \varphi(0, 0) + i\psi(0, 0) + i \cdot 0 = 0,$$

hence

$$f(z) = -i\operatorname{Log}(1+z), \quad z \in \Omega.$$

Example 6.20 Assume that the function f is analytic in the open domain $\Omega \subseteq \mathbb{C}$. Prove that at any point $z = x + iy \in \Omega$ we have the equation

$$\Delta(|f(z)|^2) = 4|f'(z)|^2,$$

where Δ denotes the Laplace differential operator.

By putting $f = u + iv$, we get

$$f'(z) = \frac{\partial u}{\partial x} + i\frac{\partial v}{\partial x},$$

and hence by just computing, using that $\Delta u = 0$ and $\Delta v = 0$, i.e. that u and v are harmonic:

$$\begin{aligned}
 \Delta (|f(z)|^2) &= \Delta (u^2 + v^2) = \frac{\partial^2}{\partial x^2} (u^2 + v^2) + \frac{\partial^2}{\partial y^2} (u^2 + v^2), \\
 &= \frac{\partial}{\partial x} \left\{ 2u \frac{\partial u}{\partial x} \right\} + \frac{\partial}{\partial y} \left\{ 2u \frac{\partial u}{\partial y} \right\} + \frac{\partial}{\partial x} \left\{ 2v \frac{\partial v}{\partial x} \right\} + \frac{\partial}{\partial y} \left\{ 2v \frac{\partial v}{\partial y} \right\} \\
 &= 2 \left\{ \frac{\partial u}{\partial x} \right\}^2 + 2u \frac{\partial^2 u}{\partial x^2} + 2u \frac{\partial^2 u}{\partial y^2} + 2 \left\{ \frac{\partial u}{\partial y} \right\}^2 + 2 \left\{ \frac{\partial v}{\partial x} \right\}^2 + 2 \left\{ \frac{\partial v}{\partial y} \right\}^2 + 2v \left\{ \frac{\partial^2 v}{\partial x^2} + \frac{\partial^2 v}{\partial y^2} \right\} \\
 &= 2 \left(\left\{ \frac{\partial u}{\partial x} \right\}^2 + \left\{ \frac{\partial u}{\partial y} \right\}^2 + \left\{ \frac{\partial v}{\partial x} \right\}^2 + \left\{ \frac{\partial v}{\partial y} \right\}^2 \right) + 2u \Delta u + 2v \Delta v \\
 &= 2 \left(\left\{ \frac{\partial u}{\partial x} \right\}^2 + \left\{ -\frac{\partial v}{\partial x} \right\}^2 + \left\{ \frac{\partial v}{\partial x} \right\}^2 + \left\{ \frac{\partial u}{\partial x} \right\}^2 \right) + 0 + 0 \\
 &= 4 \left(\left\{ \frac{\partial u}{\partial x} \right\}^2 + \left\{ \frac{\partial v}{\partial x} \right\}^2 \right) = 4 \left| \frac{\partial u}{\partial x} + i \frac{\partial v}{\partial x} \right|^2 = 4 |f'(z)|^2.
 \end{aligned}$$

Note that we have also applied *Cauchy-Riemann's equations*

$$\frac{\partial u}{\partial x} = \frac{\partial v}{\partial y} \quad \text{and} \quad \frac{\partial u}{\partial y} = -\frac{\partial v}{\partial x}.$$

Example 6.21 *In two-dimensional elasticity problems one often has to consider the biharmonic equation*

$$\Delta \Delta \Phi = \frac{\partial^4 \Phi}{\partial x^4} + 2 \frac{\partial^4 \Phi}{\partial x^2 \partial y^2} + \frac{\partial^4 \Phi}{\partial y^4} = 0.$$

Assume that Ω is an open simply connected domain. Prove that all solutions of the biharmonic equation $\Delta \Delta \Phi = 0$ are given by

$$\Phi = \operatorname{Re} \{ \bar{z} f(z) + g(z) \},$$

where the functions $f(z)$ and $g(z)$ are any analytic function in Ω .

Clearly, any harmonic function is also biharmonic.

Since $\operatorname{Re} g(z)$ is harmonic for every analytic function $g(z)$ on Ω , we shall only prove that $\operatorname{Re} \{ \bar{z} f(z) \}$ is biharmonic for every analytic function $f(z)$ on Ω in order to prove that all solutions are given as above.

If we write $f = u + i v$, then

$$\Phi_1 := \operatorname{Re} \{ \bar{z} f(z) \} = \operatorname{Re} \{ (x - i y)(u + i v) \} = xy + yv.$$

A test gives

$$\begin{aligned}
 \Delta\Delta\Phi &= \Delta\left\{\frac{\partial^2}{\partial x^2}(xu + yv) + \frac{\partial^2}{\partial y^2}(xy + yv)\right\} \\
 &= \Delta\left\{\frac{\partial}{\partial x}\left(u + x\frac{\partial u}{\partial x}\right) + y\frac{\partial^2 v}{\partial x^2} + x\frac{\partial^2 u}{\partial y^2} + \frac{\partial}{\partial y}\left(v + y\frac{\partial v}{\partial y}\right)\right\} \\
 &= \Delta\left\{2\frac{\partial u}{\partial x} + x\frac{\partial^2 u}{\partial x^2} + y\frac{\partial^2 v}{\partial x^2} + x\frac{\partial^2 u}{\partial y^2} + 2\frac{\partial v}{\partial y} + y\frac{\partial^2 v}{\partial y^2}\right\} \\
 &= 2\Delta\left\{\frac{\partial u}{\partial x}\right\} + 2\Delta\left\{\frac{\partial v}{\partial y}\right\} + \Delta\{x\Delta u + y\Delta v\} \\
 &= 2\frac{\partial}{\partial x}\{\Delta u\} + 2\frac{\partial}{\partial y}\{\Delta v\} + \Delta\{x\cdot 0 + y\cdot 0\} = 0.
 \end{aligned}$$

Conversely, assume that Φ is biharmonic in Ω . Then $\Delta\Phi$ is harmonic, and since Ω is assumed to be simply connected, there must exist an analytic function $h(z)$ on Ω , such that

$$\Delta\Phi = \operatorname{Re} h(z).$$

Again because Ω is simply connected, we can find a primitive f of $\frac{h}{4}$ in Ω , thus $f' = \frac{h}{4}$. Then we get by a similar computation as above that

$$\Delta \operatorname{Re} \{\bar{z}f(z)\} = \operatorname{Re} h = \Delta\Phi,$$

thus

$$\Delta\{\Phi - \operatorname{Re} \{\bar{z}f(z)\}\} = 0,$$

proving that $\Phi - \bar{z}f(z)$ is harmonic in Ω . Then we can find an analytic function $g(z)$ on Ω , such that

$$\Phi - \operatorname{Re} \{\bar{z}f(z)\} = \operatorname{Re} g(z),$$

and the result follows by a rearrangement.

Example 6.22 Let $\Omega = B(0, 1)$ denote the open unit disc, and assume that $h(z)$ is continuous on the boundary $|z| = 1$. Solve the boundary value problem

$$\begin{cases} \Delta u = 0, & \text{for } (x, y) \in \Omega, \\ u(x, y) = h(x, y), & \text{for } x^2 + y^2 = 1. \end{cases}$$

We introduce the function $\varphi : [0, 2\pi] \rightarrow \mathbb{R}$ or \mathbb{C} by

$$\varphi(t) := h(e^{it}) = h(\cos t, \sin t), \quad t \in [0, 2\pi].$$

Then $\varphi(t)$ is continuous, and $\varphi(0) = \varphi(2\pi)$. Then φ has a Fourier series expansion

$$\varphi(t) \sim \frac{1}{2}a_0 + \sum_{n=1}^{+\infty} \{a_n \cos nt + b_n \sin nt\},$$

where

$$a_n = \frac{1}{\pi} \int_0^{2\pi} \varphi(t) \cos nt \, dt \quad \text{and} \quad b_n = \frac{1}{\pi} \int_0^{2\pi} \varphi(t) \sin nt \, dt.$$

The solution is given by *Poisson's integral formula*,

$$u(re^{i\theta}) = \frac{1}{2\pi} \frac{1-r^2}{1+r^2-2r\cos(\theta-t)} \varphi(t) \, dt, \quad r \in [0, 1[.$$

It is well-known, or easily proved, that

$$\frac{1-r^2}{1+r^2-2r\cos(\theta-t)} = 1 + 2 \sum_{n=1}^{+\infty} r^n \cos(n(\theta-t)).$$

This series is uniformly convergent, if $0 \leq r < 1$ is kept fixed, so we can interchange the summation and the integration,

$$u(re^{i\theta}) = \frac{1}{2\pi} \int_0^{2\pi} \varphi(t) \, dt + \sum_{n=1}^{+\infty} r^n \cdot \frac{1}{\pi} \int_0^{2\pi} \varphi(t) \cos(n\theta - nt) \, dt.$$

“I studied English for 16 years but...
...I finally learned to speak it in just six lessons”
Jane, Chinese architect

ENGLISH OUT THERE

Click to hear me talking before and after my unique course download



Here,

$$\frac{1}{2\pi} \int_0^{2\pi} \varphi(t) dt = \frac{1}{2} a_0,$$

and

$$\begin{aligned} \frac{1}{\pi} \int_0^{2\pi} \varphi(t) \cos(n\theta - nt) dt &= \frac{1}{\pi} \int_0^{2\pi} \varphi(t) \cos nt dt \cdot \cos n\theta + \frac{1}{\pi} \int_0^{2\pi} \varphi(t) \sin nt dt \cdot \sin n\theta \\ &= a_n \cos n\theta + b_n \sin n\theta, \end{aligned}$$

so by insertion we get the very useful solution formula

$$u(r e^{i\theta}) = \frac{1}{2} a_0 + \sum_{n=1}^{+\infty} r^n \{a_n \cos n\theta + b_n \sin n\theta\},$$

in which we shall only perform a Fourier series expansion of the boundary value $h(e^{i\theta})$ and then add the factor r^n , $0 \leq r < 1$, to the n -th term of the Fourier series.

Example 6.23 Let $u : \mathbb{R} \times \mathbb{R} \rightarrow \mathbb{R}$ be given by

$$u(x, y) = \exp(x^2 - y^2) \cos(2xy) + e^x \sin y.$$

- 1) Prove that u is an harmonic function.
- 2) Find v , such that u and v are harmonic conjugated, and such that $v(0, 0) = 0$.
- 3) Write the function $u(x, y) + i v(x, y)$ as a function of z , where $z = x + iy$.

It follows by inspection from $z^2 = x^2 - y^2 + 2ixy$ that

$$u_1(x, y) = \exp(\operatorname{Re}\{z^2\}) \cos(\operatorname{Im}\{z^2\}) = \operatorname{Re}\{\exp(\operatorname{Re}\{z^2\} + i \operatorname{Im}\{z^2\})\} = \operatorname{Re}\{\exp(z^2)\}.$$

Analogously,

$$u_2(x, y) = e^x \sin y = \operatorname{Im}\{e^z\} = \operatorname{Re}\{-i e^z\}.$$

Then it follows that:

- 1) Since

$$u(x, y) = u_1(x, y) + u_2(x, y) = \operatorname{Re}\{\exp(z^2) - i e^z\}$$

is the real part of an analytic function, we have that $u(x, y)$ is harmonic.

- 2) Since

$$v_1(x, y) = \operatorname{Im}\{\exp(z^2) - i e^z\} = \exp(x^2 - y^2) \sin(2xy) - e^x \cos y$$

is an harmonic conjugated of $u(x, y)$ where $v_1(0, 0) = -1$, the wanted harmonic conjugated is given by

$$v(x, y) = \exp(x^2 - y^2) \sin(2xy) - e^x \cos y + 1 = \operatorname{Im}\{\exp(z^2) - i e^z + i\}.$$

3) The wanted function is

$$f(z) = \exp(z^2) - i e^z + i.$$

ALTERNATIVELY, apply the standard method.

1) We get by differentiation,

$$\frac{\partial u}{\partial x} = 2x e^{x^2-y^2} \cos(2xy) - 2y e^{x^2-y^2} \sin(2xy) + e^x \sin y,$$

$$\frac{\partial u}{\partial y} = -2y e^{x^2-y^2} \cos(2xy) - 2x e^{x^2-y^2} \sin(2xy) + e^x \cos y,$$

and

$$\begin{aligned} \frac{\partial^2 u}{\partial x^2} + \frac{\partial^2 u}{\partial y^2} &= 2 e^{x^2-y^2} \cos(2xy) + 4x^2 e^{x^2-y^2} \cos(2xy) \\ &\quad - 4xy e^{x^2-y^2} \sin(2xy) - 4xy e^{x^2-y^2} \sin(2xy) \\ &\quad - 4y^2 e^{x^2-y^2} \cos(2xy) + e^x \sin y \\ &\quad - 2 e^{x^2-y^2} \cos(2xy) + 4y^2 e^{x^2-y^2} \cos(2xy) \\ &\quad + 4xy e^{x^2-y^2} \sin(2xy) \\ &\quad + 4xy e^{x^2-y^2} \sin(2xy) + 4xy e^{x^2-y^2} \sin(2xy) \\ &\quad - 4x^2 e^{x^2-y^2} \cos(2xy) - e^x \sin y \\ &= 0, \end{aligned}$$

so $u(x, y)$ fulfils the Laplace differential equation, thus $u(x, y)$ is harmonic.

2) It follows from *Cauchy-Riemann's equations* that

$$\frac{\partial v}{\partial x} = -\frac{\partial u}{\partial y} = 2y e^{x^2-y^2} \cos(2xy) + 2x e^{x^2-y^2} \sin(2xy) - e^x \cos y,$$

$$\frac{\partial v}{\partial y} = \frac{\partial u}{\partial x} = 2x e^{x^2-y^2} \cos(2xy) - 2y e^{x^2-y^2} \sin(2xy) + e^x \sin y.$$

Thus we get the differential form

$$\begin{aligned} dv &= \frac{\partial v}{\partial x} dx + \frac{\partial v}{\partial y} dy \\ &= e^{x^2-y^2} \cos(2xy) \cdot 2y dx + e^{x^2-y^2} \sin(2xy) \cdot 2x dx \\ &\quad - \cos y \cdot e^x dx + e^{x^2-y^2} \cos(2xy) \cdot 2x dy \\ &\quad - e^{x^2-y^2} \sin(2xy) \cdot 2y dy + e^x \sin y dy \\ &= e^{x^2-y^2} \cos(2xy) d(2xy) + e^{x^2-y^2} \sin(2xy) d(x^2 - y^2) - \cos y d(e^x) - e^x d(\cos y) \\ &= e^{x^2-y^2} d\{\sin(2xy)\} + \sin(2xy) d(e^{x^2-y^2}) - d(e^x \cos y) \\ &= d\{e^{x^2-y^2}(2xy) - e^x \cos y\}, \end{aligned}$$

hence by an integration,

$$v(x, y) = e^{x^2-y^2} \sin(2xy) - e^x \cos y + c.$$

Now, $v(0, 0) = 0 = -1 + c$, so $c = 1$, and the harmonic conjugated function satisfying $v(0, 0) = 0$ is given by

$$v(x, y) = e^{x^2-y^2} \sin(2xy) - e^x \cos y + 1.$$

3) Finally.

$$\begin{aligned} f(z) &= u(x, y) + i v(x, y) \\ &= e^{x^2-y^2} \cos(2xy) + e^x \sin y + i e^{x^2-y^2} \sin(2xy) - i e^x \cos y + i \\ &= e^{x^2-y^2} \{ \cos(2xy) + i \sin(2xy) \} - i \cdot e^x \{ \cos y + i \sin y \} + i \\ &= e^{x^2-y^2} e^{2ixy} - i \cdot e^x e^{iy} + i \\ &= \exp(x^2 - y^2 + 2ixy) - i \cdot \exp(x + iy) + i \\ &= \exp(z^2) - i e^z + i. \end{aligned}$$

Excellent Economics and Business programmes at:



**university of
 groningen**



**“The perfect start
 of a successful,
 international career.”**

CLICK HERE
 to discover why both socially
 and academically the University
 of Groningen is one of the best
 places for a student to be

www.rug.nl/feb/education



Example 6.24 Let A be a domain in \mathbb{C} , and let $f : A \rightarrow \mathbb{C}$ denote an analytic function. Put $u = \operatorname{Re}(f)$ and $v = \operatorname{Im}(f)$. Prove that the product $u \cdot v$ is an harmonic function on A .

We assume that $f = u + iv$ is analytic, so u and v are harmonic and satisfy *Cauchy-Riemann's equations*,

$$\frac{\partial u}{\partial x} = \frac{\partial v}{\partial y} \quad \text{and} \quad \frac{\partial u}{\partial y} = -\frac{\partial v}{\partial x}.$$

Then

$$\begin{aligned} \frac{\partial^2}{\partial x^2} (u \cdot v) + \frac{\partial^2}{\partial y^2} (u \cdot v) &= \frac{\partial}{\partial x} \left\{ \frac{\partial u}{\partial x} \cdot v + u \cdot \frac{\partial v}{\partial x} \right\} + \frac{\partial}{\partial y} \left\{ \frac{\partial u}{\partial y} \cdot v + u \cdot \frac{\partial v}{\partial y} \right\} \\ &= \frac{\partial}{\partial x} \left\{ \frac{\partial v}{\partial y} \cdot v - u \cdot \frac{\partial u}{\partial y} \right\} + \frac{\partial}{\partial y} \left\{ -\frac{\partial v}{\partial x} \cdot v + u \cdot \frac{\partial u}{\partial x} \right\} \\ &= \frac{1}{2} \frac{\partial}{\partial x} \left\{ \frac{\partial v^2}{\partial y} - \frac{\partial u^2}{\partial y} \right\} + \frac{1}{2} \frac{\partial}{\partial y} \left\{ -\frac{\partial v^2}{\partial x} + \frac{\partial u^2}{\partial x} \right\} \\ &= \frac{1}{2} \left\{ \frac{\partial^2 v^2}{\partial x \partial y} - \frac{\partial^2 u^2}{\partial x \partial y} - \frac{\partial^2 v^2}{\partial x \partial y} + \frac{\partial^2 u^2}{\partial x \partial y} \right\} \\ &= 0, \end{aligned}$$

and it follows that $u \cdot v$ is harmonic.

Example 6.25 Let $u : \mathbb{R}^2 \rightarrow \mathbb{R}$ be given by

$$u(x, y) = e^x (x \cos y - y \sin y).$$

- 1) Prove that u is an harmonic function.
- 2) Find all harmonic conjugated functions $v : \mathbb{R}^2 \rightarrow \mathbb{R}$, for which $u + iv$ is analytic, and write all these functions $u + iv$ as a function in z , where $z = x + iy$.

- 1) It follows by INSPECTION that

$$u(x, y) = e^x \{x \cos y - y \sin y\} = \operatorname{Re} \{(x + iy)e^{x+iy}\} = \operatorname{Re} \{z e^z\}.$$

Since $z e^z$ is analytic, $u(x, y)$ is harmonic.

- 2) An harmonic conjugated function is given by

$$v(x, y) = \operatorname{Im} \{z e^z\} = e^x \{x \sin y + y \cos y\}.$$

Then all harmonic conjugated functions are given by

$$v(x, y) = c + e^x \{x \sin y + y \cos y\},$$

and furthermore,

$$f(z) = u(x, y) + i v(x, y) = z e^z + ic, \quad c \in \mathbb{R}.$$

ALTERNATIVELY:

1) The function

$$u(x, y) = e^x \{x \cos y - y \sin y\}$$

has the derivatives

$$\begin{aligned}\frac{\partial u}{\partial x} &= e^x \{x \cos y - y \sin y + \cos y\}, \\ \frac{\partial^2 u}{\partial x^2} &= e^x \{x \cos y - y \sin y + 2 \cos y\}, \\ \frac{\partial v}{\partial y} &= e^x \{-x \sin y - y \cos y - \sin y\}, \\ \frac{\partial^2 v}{\partial y^2} &= e^x \{-x \cos y + y \sin y - 2 \cos y\}.\end{aligned}$$

Since

$$\frac{\partial^2 u}{\partial x^2} + \frac{\partial^2 u}{\partial y^2} = 0,$$

it follows that $u(x, y)$ is an harmonic function.

2) Assume that $v(x, y)$ is an harmonic conjugated function. Then by *Cauchy-Riemann's equations*,

$$\begin{aligned}dv &= \frac{\partial v}{\partial x} dx + \frac{\partial v}{\partial y} dy = -\frac{\partial u}{\partial y} dx + \frac{\partial u}{\partial x} dy \\ &= e^x \{x \sin y + y \cos y + \sin y\} dx + e^x \{x \cos y - y \sin y + \cos y\} dy \\ &= \sin y d(x e^x) + y \cos y d(e^x) + x e^x d(\sin y) + e^x d(y \cos y) \\ &= d(x e^x \sin y + y \cos y \cdot e^x),\end{aligned}$$

and we get by an integration

$$v(x, y) = c + e^x (x \sin y + y \cos y).$$

Finally,

$$\begin{aligned}f(z) &= u(x, y) + i v(x, y) \\ &= e^x \{x \cos y - y \sin y\} + i e^x \{x \sin y + y \cos y\} + ic \\ &= x e^x \{\cos y + i \sin y\} + i y e^x \{\cos y + i \sin y\} + ic \\ &= (x + iy) e^{x+iy} + ic = z e^z + ic.\end{aligned}$$

Example 6.26 Let $u : \mathbb{R}^2 \rightarrow \mathbb{R}$ be given by

$$u(x, y) = x^4 + y^4 - 6x^2y^2 + x - y + 1.$$

- 1) Prove that u is an harmonic function.
- 2) Find all the harmonic conjugated functions $v : \mathbb{R}^2 \rightarrow \mathbb{R}$, for which $u + iv$ is analytic, and write each of these functions $u + iv$ as a function in z alone, where $z = x + iy$.

- 1) Since $u(x, y)$ is a sum of polynomials of fourth degree and of first degree, it will be quite reasonable to guess on a linear combination of the real parts and the imaginary parts of z^4 and z . It follows by a computation that

$$z^4 = (x + iy)^4 = x^4 - 6x^2y^2 + y^4 + i \{4x^3y - 4xy^3\}.$$

When we compare this with the expression of $u(x, y)$ it follows that

$$u(x, y) = x^4 + y^4 - 6x^2y^2 + x - y + 1 = \operatorname{Re}(z^4) + \operatorname{Re}(z) + \operatorname{Re}(iz) = \operatorname{Re}\{z^4 + (1 + i)z\}.$$

Since $z^4 + (1 + i)z$ is analytic in \mathbb{C} , and $u(x, y)$ is the real part, we conclude that $u(x, y)$ is harmonic.

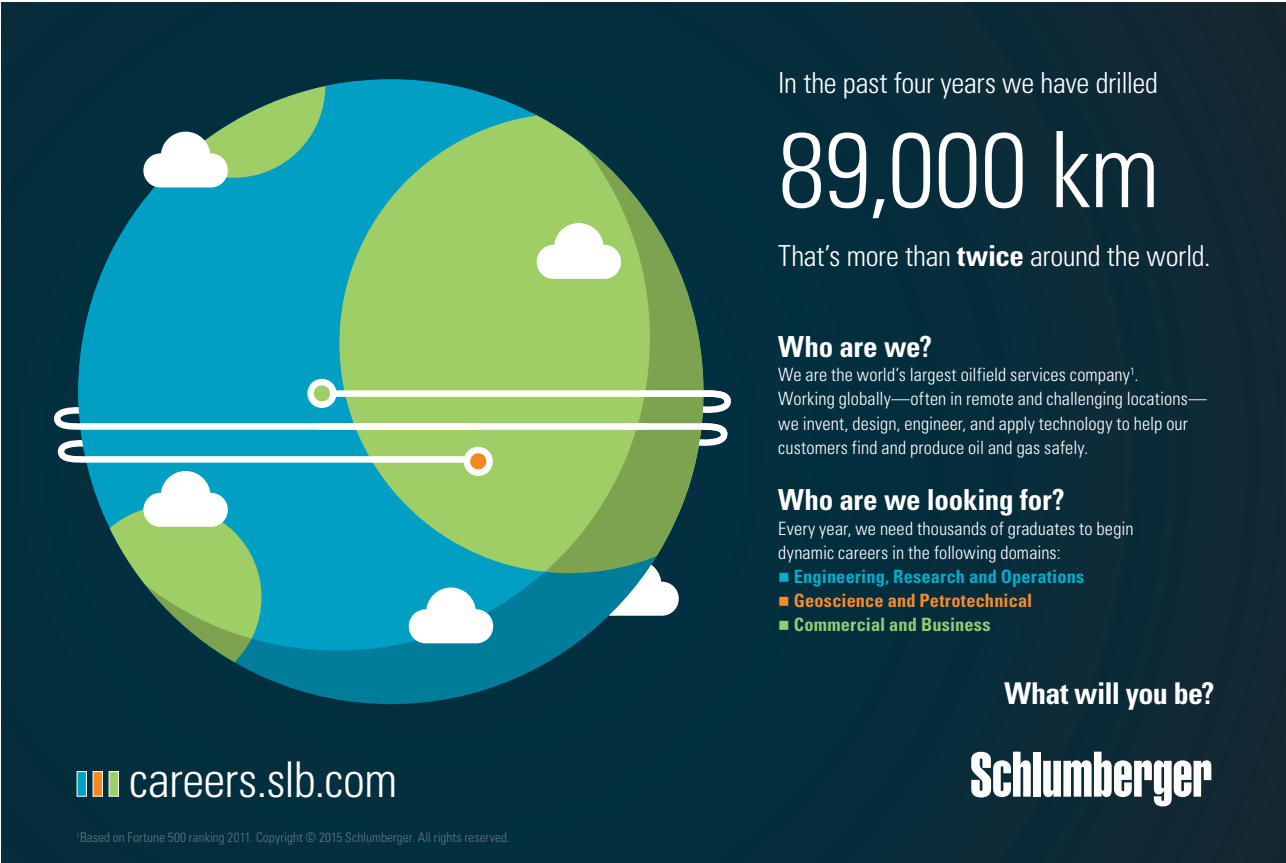

In the past four years we have drilled

89,000 km

That's more than **twice** around the world.

Who are we?
We are the world's largest oilfield services company¹. Working globally—often in remote and challenging locations—we invent, design, engineer, and apply technology to help our customers find and produce oil and gas safely.

Who are we looking for?
Every year, we need thousands of graduates to begin dynamic careers in the following domains:

- Engineering, Research and Operations
- Geoscience and Petrotechnical
- Commercial and Business

What will you be?

careers.slb.com

Schlumberger

¹Based on Fortune 500 ranking 2011. Copyright © 2015 Schlumberger. All rights reserved.



2) All harmonic conjugated functions are then

$$v(x, y) = \operatorname{Im} \{ z^4 + (1 + i)z \} + c = 4x^3y - 4xy^3 + x + y + c,$$

where $c \in \mathbb{R}$ is an arbitrary constant.

We have already mentioned that

$$f(z) = u(x, y) + i v(x, y) = z^4 + (1 + i)z + ic, \quad c \in \mathbb{R}.$$

ALTERNATIVELY we apply the standard method.

1) We get by differentiation,

$$\begin{aligned} \frac{\partial u}{\partial x} &= 4x^3 - 12xy^2 + 1, & \frac{\partial u}{\partial y} &= 4y^3 - 12x^2y - 1, \\ \frac{\partial^2 u}{\partial x^2} &= 12x^2 - 12y^2, & \frac{\partial^2 u}{\partial y^2} &= 12y^2 - 12x^2. \end{aligned}$$

It follows that

$$\frac{\partial^2 u}{\partial x^2} + \frac{\partial^2 u}{\partial y^2} = 0,$$

which implies that $u(x, y)$ is harmonic.

2) Then by *Cauchy-Riemann's equations*, at

$$\begin{aligned} dv &= \frac{\partial v}{\partial x} dx + \frac{\partial v}{\partial y} dy = -\frac{\partial u}{\partial y} dx + \frac{\partial u}{\partial x} dy = \{-4y^3 + 12x^2y + 1\} dx + \{4x^3 - 12xy^2 + 1\} dy \\ &= \{-4y^3 dx - 4x d(y^3)\} + \{4y d(x^3) + 4x^3 dy\} + dx + dy = d\{-4xy^3 + 4x^3y + x + y\}. \end{aligned}$$

Then an integration gives that all harmonic conjugated functions are given by

$$v(x, y) = 4x^3y - 4xy^3 + x + y + c, \quad c \in \mathbb{R}.$$

Finally,

$$\begin{aligned} f(z) &= u(x, y) + i v(x, y) = x^4 + 4x^3(iy) + 6x^2(iy)^2 + 4x(iy)^3 + (iy)^4 + (x + iy) + i(x + iy) + ic \\ &= (x + iy)^4 + (1 + i)(x + iy) + ic = z^4 + (1 + i)z + ic, \quad c \in \mathbb{R}. \end{aligned}$$