

An introduction to the theory of complex variables

R.S. Johnson



Download free books at

bookboon.com

R.S. Johnson

An introduction to the theory of complex variables

An introduction to the theory of complex variables

© 2012 R.S. Johnson & bookboon.com

ISBN 978-87-403-0162-5

Contents

	Preface to these two texts	8
	Part I: An introduction to complex variables	9
	Preface	10
	Introduction	11
1	Complex Numbers	12
1.1	Elementary properties	12
1.2	Inequalities	15
1.3	Roots	16
	Exercises 1	18
2	Functions	20
2.1	Elementary functions	21
	Exercises 2	27
3	Differentiability	29
3.1	Definition	29
3.2	The derivative in detail	31
3.3	Analyticity	37

www.sylvania.com

**We do not reinvent
the wheel we reinvent
light.**

Fascinating lighting offers an infinite spectrum of possibilities: Innovative technologies and new markets provide both opportunities and challenges. An environment in which your expertise is in high demand. Enjoy the supportive working atmosphere within our global group and benefit from international career paths. Implement sustainable ideas in close cooperation with other specialists and contribute to influencing our future. Come and join us in reinventing light every day.

Light is OSRAM

**OSRAM
SYLVANIA**

3.4	Harmonic functions	38
	Exercises 3	41
4	Integration in the complex plane	42
4.1	The line integral	42
4.2	The fundamental theorem of calculus	45
4.3	Closed contours	46
	Exercises 4	51
5	The Integral Theorems	53
5.1	Cauchy's Integral Theorem (1825)	53
5.2	Cauchy's Integral Formula (1831)	56
5.3	An integral inequality	63
5.4	An application to the evaluation of real integrals	66
	Exercises 5	70
6	Power Series	71
6.1	The Laurent expansion (1843)	73
	Exercises 6	78
7	The Residue Theorem	80
7.1	The (Cauchy) Residue Theorem (1846)	80
7.2	Application to real integrals	84



Discover the truth at www.deloitte.ca/careers

Deloitte.

© Deloitte & Touche LLP and affiliated entities.



7.3	Using a different contour	87
	Exercises 7	90
8	The Fourier Transform	93
8.1	FTs of derivatives	97
	Exercises 8	98
	Answers	99
	Part II: The integral theorems of complex analysis with applications to the evaluation of real integrals	106
	List of Integrals	107
	Preface	109
	Introduction	110
1.1	Complex integration	110
	Exercises 1	112
2	The integral theorems	113
2.1	Green's theorem	113
2.2	Cauchy's integral theorem	114
2.3	Cauchy's integral formula	117

SIMPLY CLEVER

ŠKODA



We will turn your CV into
an opportunity of a lifetime



Do you like cars? Would you like to be a part of a successful brand?
We will appreciate and reward both your enthusiasm and talent.
Send us your CV. You will be surprised where it can take you.

Send us your CV on
www.employerforlife.com



Click on the ad to read more

2.4	The (Cauchy) residue theorem	120
	Exercises 2	124
3	Evaluation of simple, improper real integrals	125
3.1	Estimating integrals on semi-circular arcs	126
3.2	Real integrals of type 1	128
3.3	Real integrals of type 2	132
	Exercises 3	135
4	Indented contours, contours with branch cuts and other special contours	136
4.1	Cauchy principal value	136
4.2	The indented contour	140
4.3	Contours with branch cuts	144
4.4	Special contours	150
	Exercises 4	155
5	Integration of rational functions of trigonometric functions	156
	Exercises 5	159
	Answers	160
	Biographical Notes	161
	Index	171

I joined MITAS because
I wanted **real responsibility**

The Graduate Programme
for Engineers and Geoscientists
www.discovermitas.com



Real work
International opportunities
Three work placements



Month 16
I was a construction
supervisor in
the North Sea
advising and
helping foremen
solve problems



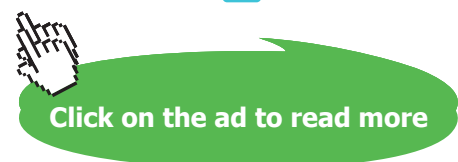

Preface to these two texts

The two texts in this one cover, entitled ‘An introduction to complex variables’ (Part I) and ‘The integral theorems of complex analysis with applications to the evaluation of real integrals’ (Part II), are versions of material available to students at Newcastle University (UK). The first is an introductory text, based on a lecture course developed by the author; the second provides additional and background reading (being one of the ‘Notebook’ series). The material in Part I is a familiar topic encountered in mathematical studies at university, although here it is given a more ‘methods’ slant rather than a ‘pure’ slant. (Complex analysis is a subject that straddles both pure and applied mathematics and it can be taught with either aspect – or both – being emphasised.) The material in Part II builds on the introductory ideas on integration in Part I; these are first summarised (and presented in a slightly different form) and then more extensive and advanced applications are described.

Each text is designed to be equivalent to a traditional text, or part of a text, which covers the relevant material, with many worked examples and set exercises being presented in Part I (and a few additional exercises in Part II). The appropriate background for each is mentioned in the preface to each part, and there is a comprehensive index, covering both parts, at the end; we have also included some biographical notes.

Part I

An introduction to complex variables

Preface

This text is based on a lecture course developed by the author and given to students in the second year of study in mathematics at Newcastle University. This has been written to provide a typical course (for students with a general mathematical background) that introduces the main ideas, concepts and techniques, rather than a wide-ranging and more general text on complex analysis. Thus the topics, with their detailed discussion linked to the many carefully worked examples, do not cover as broad a spectrum as might be found in other, more conventional texts on complex analysis; this is a quite deliberate choice here. Nevertheless, all the usual introductory material is included and its development is probably more extensive than in a conventional text. The material, and its style of presentation, have been selected after a number of years of development and experience, based on various approaches to this topic, resulting in something that works well in the lecture theatre. Thus, for example, some of the more technical (pure mathematical) aspects are not pursued here.

We include a large number of worked examples, and an extensive set of exercises (to which answers are provided). We also provide brief biographical notes on most of the important contributors to complex analysis (who are mentioned here).

It is assumed that the reader has some knowledge of the elementary functions, and a considerable acquaintance with the differential and integral calculus – but no more than is typically covered in the first year of university study – and also some experience working with complex numbers. In addition, we make use of Green's theorem and line integrals, so some knowledge of these is recommended.

Introduction

Complex analysis, and particularly the theory associated with the integral theorems, is an altogether amazing and beautiful branch of mathematics that comfortably straddles pure and applied mathematics. It not only provides the opportunity to analyse and present in a very formal way, but also it introduces a powerful tool in mathematical methods. The results that we describe are due, in the main, to the seminal work of *Cauchy*; in particular, these enable us to represent many problems in integration in a purely *algebraic form*. The results are all amazingly simple and beautiful, although based on deep and subtle ideas. The techniques are applicable, most directly and naturally, to conventional integration, but they are also important in potential flow theory (as required, for example, in the study of fluid mechanics).

We start with a brief reminder of the properties of elementary complex numbers. Then we introduce the notion of a *complex function*: a complex-valued function of a complex variable. (The subject is often called ‘the theory of functions of a complex variable’, or simply ‘complex variables’; more formally, we refer to ‘complex analysis’, although we do not assume a background in classical real analysis.) This idea naturally leads to an investigation of the differentiation and integration of such functions. As we shall see, the conventional ideas of both these basic concepts have to be modified somewhat when working in the complex plane. Thus we need to develop the notion of a derivative, introduce some fundamental theorems for integration and also describe power series.

We will apply our new ideas and methods to the evaluation of certain classical (real) integrals, and also introduce an important tool used in many branches of mathematics, physics and engineering: the Fourier Transform.

1 Complex Numbers

The aim, in this first chapter, is to collect together the standard and familiar ideas associated with complex numbers, and their manipulation and use in finding roots of simple equations. So we start with the notation for a complex number written as

$$z = x + iy$$

the *Cartesian* or *real-imaginary* form; an alternative is

$$z = re^{i\theta} = r(\cos \theta + i \sin \theta)$$

the *polar* form, where r is the *modulus* and θ the *arg*. We may relate these two alternative expressions for a complex number by noting that $r = |z| = \sqrt{x^2 + y^2}$ and $\tan \theta = y/x$. We may also represent the complex number in the Argand plane – the *complex plane*:

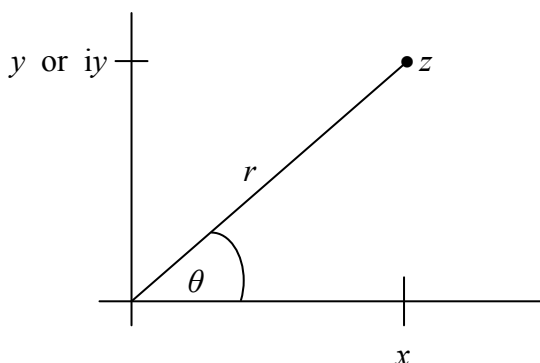

This complex plane, and correspondingly the set of all complex numbers, is usually labelled \mathbb{C} . Here, x , y , r and θ are all real, so we have $(x, y, \theta) \in \mathbb{R}$ and $r \geq 0$ (where \mathbb{R} is the set of all real numbers); we also have, of course, $i = \sqrt{-1}$. (You may come across ‘ j ’ as the symbol for $\sqrt{-1}$; this is sometimes used in electrical problems where ‘ i ’ is reserved for *current*.)

1.1 Elementary properties

First we list the fundamental algebraic rules obeyed by complex numbers, which we simply quote here, without justification or detailed explanation; all this is regarded as relevant background material for the ideas that we shall develop later.

(a) Addition

Given two numbers, $z_1 = x_1 + iy_1$ and $z_2 = x_2 + iy_2$, then

$$z_1 + z_2 = x_1 + x_2 + i(y_1 + y_2),$$

which mirrors the rule for the addition of vectors:

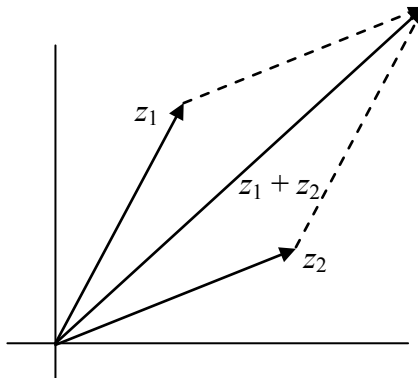

(b) Product

With the notation used in (a), we have

$$z_1 z_2 = (x_1 + iy_1)(x_2 + iy_2) = x_1 x_2 - y_1 y_2 + i(x_1 y_2 + x_2 y_1),$$

but this is more neatly expressed in the polar form:

ie business school

#1 EUROPEAN BUSINESS SCHOOL
FINANCIAL TIMES 2013

#gobeyond

MASTER IN MANAGEMENT

Because achieving your dreams is your greatest challenge. IE Business School's Master in Management taught in English, Spanish or bilingually, trains young high performance professionals at the beginning of their career through an innovative and stimulating program that will help them reach their full potential.

- Choose your area of specialization.
- Customize your master through the different options offered.
- Global Immersion Weeks in locations such as London, Silicon Valley or Shanghai.

Because you change, we change with you.

www.ie.edu/master-management | mim.admissions@ie.edu | Facebook | Twitter | LinkedIn | YouTube | Instagram



$$z_1 z_2 = r_1 e^{i\theta_1} r_2 e^{i\theta_2} = r_1 r_2 e^{i(\theta_1 + \theta_2)}.$$

This shows that the arg of the product is simply the sum of the args of the two numbers involved in the product.

(c) Quotient

Corresponding to (b), we present this in two different ways:

$$\frac{z_1}{z_2} = \frac{x_1 + iy_1}{x_2 + iy_2} = \frac{x_1 + iy_1}{x_2 + iy_2} \frac{x_2 - iy_2}{x_2 - iy_2}$$

where we have introduced the conjugate (see below) of the denominator, and so we get

$$= \frac{(x_1 + iy_1)(x_2 - iy_2)}{x_2^2 + y_2^2} = \frac{x_1 x_2 + y_1 y_2}{x_2^2 + y_2^2} + i \frac{x_2 y_1 - x_1 y_2}{x_2^2 + y_2^2},$$

or, in polars,

$$\frac{z_1}{z_2} = \frac{r_1 e^{i\theta_1}}{r_2 e^{i\theta_2}} = \frac{r_1}{r_2} e^{i(\theta_1 - \theta_2)},$$

which involves the difference of the args.

(d) Conjugate

The *conjugate* of a complex number is defined as $\bar{z} = x - iy$ (but sometimes the alternative notation z^* is used). This complex number has the following properties:

$$z\bar{z} = x^2 + y^2 = |z|^2$$

and

$$\overline{z_1 + z_2} = \bar{z}_1 + \bar{z}_2, \quad \overline{z_1 z_2} = \bar{z}_1 \bar{z}_2, \quad \overline{\bar{z}} = z.$$

(We note the useful result $\frac{1}{z} = \frac{\bar{z}}{z\bar{z}} = \frac{\bar{z}}{|z|^2}$, which we used in (c) above; this is the familiar method for rewriting a fractional term in real-imaginary form.).

Example 1 *Complex numbers.* Given $z_1 = 1 - 2i$, $z_2 = 3 + 2i$, find $z_1 z_2$ and z_1 / z_2 .

Here we have $z_1 z_2 = (1 - 2i)(3 + 2i) = 3 + 4 + i(-6 + 2) = 7 - 4i$; also

$$\frac{z_1}{z_2} = \frac{1-2i}{3+2i} = \frac{1-2i}{3+2i} \cdot \frac{3-2i}{3-2i} = \frac{(1-2i)(3-2i)}{9+4}$$

$$= \frac{1}{13} [3-4+i(-6-2)] = -\frac{1}{13} - \frac{8}{13}i.$$

Note: It is usual to write complex numbers in the real-imaginary form, wherever possible (but, of course, there may be situations where the polar form is more convenient, because it may easier to work with this format).

1.2 Inequalities

An important idea, that we shall need later, is provided by the application of elementary geometrical inequalities (associated with triangles) to complex numbers. The fundamental result that we need (which comes from Euclid, Book I, Proposition 20) is this: the sum of the lengths of any two sides of a triangle is always greater than the length of the third side. Consider these two triangles:

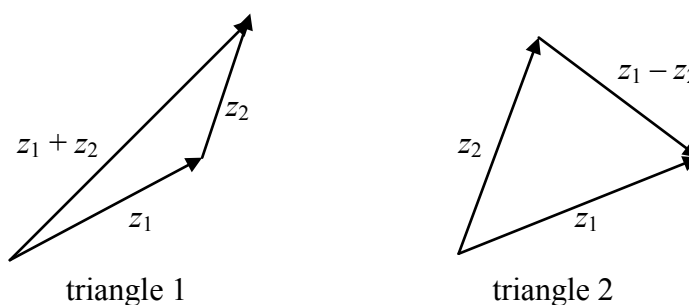

In the construction depicted in triangle 1, we have immediately that

$$|z_1| + |z_2| \geq |z_1 + z_2|,$$

where equality applies only as the enclosed area of the triangle decreases to zero, by allowing a vertex to be brought down onto the opposite side. In triangle 2, we have

$$|z_1 - z_2| + |z_1| \geq |z_2| \quad \text{and also} \quad |z_1 - z_2| + |z_2| \geq |z_1|;$$

these two expressions give, respectively,

$$|z_1 - z_2| \geq |z_2| - |z_1| \quad \text{and} \quad |z_1 - z_2| \geq |z_1| - |z_2|,$$

which together imply

$$|z_1 - z_2| \geq \left| |z_1| - |z_2| \right|,$$

although the former identity is likely to be the more useful.

(This second identity can be deduced from the first by using the same argument as for the pair above, after a simple relabelling e.g. $|z_1| \geq |z_1 + z_2| - |z_2|$ and then writing $z_1 - z_2$ for z_1 ; this is left as an exercise for the interested reader.)

Example 2 *Inequalities.* Confirm the first triangle inequality for $z_1 = 1 + 2i$, $z_2 = 2 - 3i$.

We have $|z_1| = \sqrt{5}$, $|z_2| = \sqrt{13}$ and $|z_1 + z_2| = |3 - i| = \sqrt{10}$ i.e.

$$|z_1| + |z_2| = \sqrt{5} + \sqrt{13} > \sqrt{10}, \text{ confirming the identity in this case.}$$

1.3 Roots

A very familiar – and famous – identity is *de Moivre’s theorem*:

$$e^{in\theta} = (e^{i\theta})^n = (\cos \theta + i \sin \theta)^n = \cos n\theta + i \sin n\theta, \quad n \in \mathbb{R},$$



STUDY AT A TOP RANKED INTERNATIONAL BUSINESS SCHOOL

Reach your full potential at the Stockholm School of Economics, in one of the most innovative cities in the world. The School is ranked by the Financial Times as the number one business school in the Nordic and Baltic countries.

Visit us at www.hhs.se





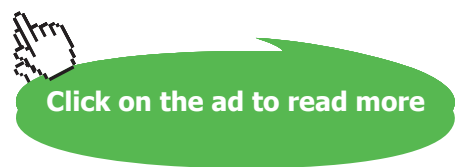

which has as a special case Euler’s even-more-famous identity. (Although de Moivre was the first to use this type of result – in about 1722 – it was only implied by one of his expressions, and then only for positive integers; a similar result in terms of logs had been obtained by Cotes in 1714. However, it was left to Euler in 1747 to complete the proof and statement of the identity that we usually associate with de Moivre.) Let us now add the important property that the arg of a complex number is not unique, as represented in the complex plane, i.e. we have

$$z = re^{i\theta} = re^{i(\theta+2k\pi)}, \quad k \in \mathbb{Z},$$

by virtue of complete rotations in the Argand plane. (Here, \mathbb{Z} as the set of all integers $\dots, -2, -1, 0, 1, 2, \dots$.) Thus, given a unique complex number z (in real-imaginary form and so, correspondingly, a unique point in the Argand plane), there is no unique representation of this in polar form.

Now, suppose that we have the equation $z^n = z_0$, for some given (integer) n and given complex number z_0 ; this can be expressed as

$$z^n = z_0 = r_0 e^{i\theta_0} = r_0 e^{i(\theta_0+2k\pi)} \quad \text{and so} \quad z = r_0^{1/n} e^{i(\theta_0+2k\pi)/n}.$$

Then, for any continuous sequence of integers, k (e.g. $k = 0, 1, 2, \dots, n-1$), this generates the n roots of the equation.

Example 3 *Roots.* Find all the roots of $z^3 = 1$.

First, we write $z^3 = 1 = 1 \cdot e^{i \cdot 0} = e^{2in\pi}$; thus $z = e^{i2n\pi/3}$, and we may elect to use $n = 0, 1, 2$. The three roots are therefore

$$z = 1, e^{i2\pi/3}, e^{i4\pi/3},$$

which can be written more conveniently as

$$e^{i2\pi/3} = \cos\left(\frac{2\pi}{3}\right) + i \sin\left(\frac{2\pi}{3}\right) = \frac{1}{2}(-1 + i\sqrt{3}) (= \omega)$$

with $e^{i4\pi/3} = \omega^2 = \frac{1}{4}(1 - i\sqrt{3})^2 = \frac{1}{4}(1 - 3 - 2i\sqrt{3}) = -\frac{1}{2}(1 + i\sqrt{3}) (= \bar{\omega})$.

The three roots are shown in the Argand plane below

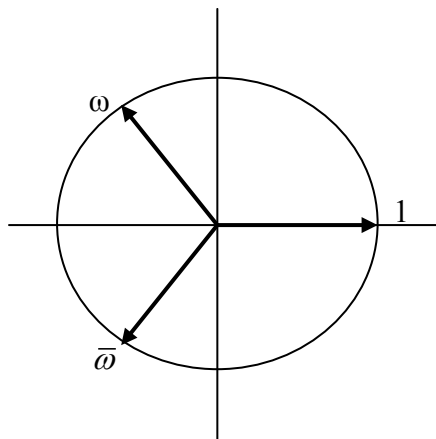

(You might have observed that $1 + \omega + \omega^2 = 0$, which is the obvious condition on the sum of the three roots of the cubic when written as $z^3 + 0.z^2 + 0.z - 1 = 0$: the second zero here shows that the roots *necessarily* sum to zero.)

Comment: We are indebted to Euler for making e , π and i popular (although he was not the first to introduce them). He did, however, find that ‘most beautiful result’ – his words – $e^{i\pi} = -1$ (*Euler’s identity*). At the end of this text, we provide some brief biographical notes, with a little historical background, of those who have contributed to the study of complex functions. (We have omitted those who worked essentially only on complex numbers; such a list – and an associated history – would be very extensive and beyond the main thrust of this text.)

Exercises 1

- Given the complex numbers $z_1 = -1 + i$ and $z_2 = 2 + 3i$
 - find $|z_1|$, $|z_2|$, $|z_1 z_2|$, \bar{z}_1 and $z_1 \bar{z}_1$;
 - write in real-imaginary ($x + iy$) form: $\frac{z_2}{z_1}$, $\frac{1}{z_2}$, $\frac{z_1 - z_2}{z_1 + z_2}$.
- Represent the complex numbers $z_1 = -1 + i$, $z_2 = 2 + 3i$ in the Argand diagram; add to this figure the complex numbers: $z_1 + z_2$, $z_2 - z_1$ and $z_1 z_2$.
- Confirm the triangle inequalities ($|z_1| + |z_2| \geq |z_1 + z_2|$, $|z_1 - z_2| \geq \left| |z_1| - |z_2| \right|$) for
 - $z_1 = -1 + i$, $z_2 = 2 + 3i$;
 - $z_1 = 2 - i$, $z_2 = 3 + i$.
- Represent the complex numbers $z_1 = 2e^{i\pi/4}$ and $z_2 = 3e^{i\pi/3}$ in the Argand diagram; add to this figure the complex numbers: $z_1 z_2$ and z_2/z_1 .
- Find the modulus and argument of these complex numbers:
 - -1 ;
 - i ;
 - $1 + i$;
 - $1 - i$;
 - $\frac{1+i}{1-i}$;
 - $\left(\frac{1+i}{1-i}\right)^{2007}$.

6. Write these complex numbers in polar ($re^{i\theta}$) form:

(a) $2i$; (b) -1 ; (c) $-1+i$; (d) $1+i\sqrt{3}$.

7. Write these in real-imaginary ($x+iy$) form:

(a) $\frac{1}{2}(1+i)^2$, $\frac{1}{4}(1+i)^4$, $\left(\frac{1+i}{\sqrt{2}}\right)^{2007}$; (b) $\frac{1+i}{1-i}$, $\left(\frac{1+i}{1-i}\right)^3$, $\left(\frac{1+i}{1-i}\right)^{3000}$.

8. Find all the roots (which you may write in polar form) of these equations:

(a) $z^4 = 1$; (b) $z^4 = -1$; (c) $z^2 = -i$; (d) $z^3 = -27i$.

9. Find all the roots of $z^3 = -1$, and then write them in real-imaginary form. Label the three different roots z_1, z_2, z_3 , and hence find the values of $z_1 + z_2 + z_3$ and of $z_1z_2 + z_2z_3 + z_3z_1$. Why was this result to be expected?

#1
in eco-friendly attitude

**STUDY AT
LINKÖPING UNIVERSITY, SWEDEN**
RANKED AMONG TOP 50 UNIVERSITIES UNDER 50

Interested in Strategy and Management in International Organisations? Kick-start your career with a master's degree from Linköping University, Sweden.

[→ Click here!](#)

Linköping University

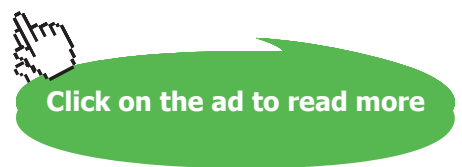

2 Functions

In order to initiate our investigation of functions, expressed in terms of complex quantities, we write $z = x + iy$ and then introduce a function of this variable as

$$w = f(z)$$

(which maps from \mathbb{C} to \mathbb{C} i.e. w is also complex-valued, in general). We note that \bar{z} is not included as an argument of the function here – and this is an important requirement, with significant consequences, which we shall develop later. We have introduced a *complex function*. For any $f(z)$, w can be expressed in real-imaginary form:

$$w = f(z) = f(x + iy) = u(x, y) + iv(x, y),$$

where u and v are real-valued functions of their arguments. (We observe that one immediate consequence of this is that we are now working in a 4-space: the Argand plane, containing the given complex numbers, is a 2-space, and at each point (each z) there exists a ‘complex number’, with a real (u) and an imaginary (v) part, thereby generating a 4-dimensional space.)

We will assume that it is always possible to write a complex function in real and imaginary parts; indeed, it is altogether straightforward to confirm this whenever $f(z)$ is an elementary function, or when it can be expressed as a power series (for example, as a Taylor expansion of the form $f(z) = \sum_{n=0}^{\infty} a_n z^n$). We will always do this explicitly, whenever we can and need to – but the assumption is always there that, in principle, real and imaginary parts exist. So, for example, we might have the functions

$$w = z + z^2 = x + iy + (x + iy)^2 = x + x^2 - y^2 + i(y + 2xy),$$

or
$$w = |z| = \sqrt{x^2 + y^2} \quad (\text{which happens to be pure real});$$

other functions that we work with might be

$$w = z^3 + 2iz, \quad w = z^{1/2}, \quad w = \frac{1}{1+z^2} \quad (z \neq \pm i).$$

We now pose a question that will, eventually, have significant ramifications in all that we develop in this study of complex functions. Given $f(z)$ we can find $f = u + iv$ but, given u and v , can we find $f(z)$? Indeed, does it even matter if we cannot find f given u and v ? To see what is involved, we look at this simple example.

Example 4 *Function of a Complex Variable.* Given $u(x, y) = x^2$ and $v(x, y) = y^2$, find $f(z) = u + iv$, if this exists.

To proceed with this calculation, we first introduce $z = x + iy$ and $\bar{z} = x - iy$; these are linearly independent in the complex plane i.e. for $y \neq 0$. Thus

$$x = \frac{1}{2}(z + \bar{z}), \quad y = \frac{1}{2i}(z - \bar{z}) = -\frac{1}{2}i(z - \bar{z}),$$

and so

$$\begin{aligned} u + iv &= x^2 + iy^2 = \frac{1}{4}(z + \bar{z})^2 + i\left(-\frac{1}{4}\right)(z - \bar{z})^2 \\ &= \frac{1}{4}[z^2 + 2z\bar{z} + \bar{z}^2 - i(z^2 - 2z\bar{z} + \bar{z}^2)] \end{aligned}$$

which is not a function of only z – it depends on both z and \bar{z} . In this case, for the given u and v , an $f(z)$ does not exist.

So we see that, although $f(z)$ does not exist, a suitable $f(z, \bar{z})$ does. On the other hand, the choice $u = x^2 - y^2, v = 2xy$, gives

$$\begin{aligned} u + iv &= \frac{1}{4}(z + \bar{z})^2 - \left(-\frac{1}{4}\right)(z - \bar{z})^2 + i2 \cdot \frac{1}{2}(z + \bar{z}) \cdot \left(-\frac{1}{2}i\right)(z - \bar{z}) \\ &= \frac{1}{4}(2z^2 + 2\bar{z}^2) + \frac{1}{2}(z^2 - \bar{z}^2) = z^2 \end{aligned}$$

which is a function of z only. This apparent complication (Example 4) in defining $f(z)$ (even for simple choices of u and v) will lead to a fundamental idea that underpins the theory of complex variables. However, before we explore this in any depth (as we do in the next chapter), we will first examine (and suitably define) some elementary functions – those that are familiar from any discussion of real functions in elementary mathematics.

2.1 Elementary functions

Here, we will briefly consider polynomial functions, and the binomial theorem, as well as the exponential function (and other functions whose definition is based on this) and the logarithmic function (which does, as we shall see, introduce a new complication). This last example of an elementary function enables us to produce a suitable definition of z^α , for arbitrary α .

(a) Polynomial functions

This function takes the general form

$$f(z) = a_0 + a_1z + a_2z^2 + \dots + a_nz^n,$$

for finite integers n , where each a_i is, in general, a complex constant. It is immediately clear that we may write

$$a_0 + a_1z + \dots + a_nz^n = b_0 + ic_0 + (b_1 + ic_1)(x + iy) + \dots + (b_n + ic_n)(x + iy)^n,$$

where we have set $a_i = b_i + ic_i$ (for real constants b_i, c_i), and then the expansion of this expression immediately yields the real-imaginary form for $f(z)$.

(b) Binomial theorem

The previous function, being polynomial, requires the expansion of terms like $(x + iy)^n$ (and so uses the elementary rules of multiplication for complex numbers), which constitutes a simple variant of the binomial theorem. The general binomial theorem itself takes the familiar form:

$$(1 + z)^n = 1 + nz + \frac{n(n-1)}{2!}z^2 + \dots + z^n = \sum_{m=0}^n \binom{n}{m} z^m,$$

with the standard notation: $\binom{n}{m} = \frac{n!}{m!(n-m)!}$; this requires the same rules of multiplication, of course. Such a development also holds for any negative integer, and so, for example, we have

$$(1 + z)^{-1} = 1 - z + z^2 - \dots = \sum_{n=0}^{\infty} (-z)^n \text{ (for } |z| < 1).$$

The only difference between the conventional validity (familiar for real functions) is that, now, this expansion holds in a *circle* $|z| < 1$ around $z = 0$ in the complex plane. (The validity, i.e. convergence, in this domain is readily confirmed; for example, by writing $z = re^{i\theta}$ and noting that $|z| = r$ (because $|e^{i\theta}| = 1$), and then $r < 1$ ensures convergence, which is equivalent to the requirement $|z| < 1$.) The extension of the binomial theorem to fractional powers requires a little more care; see (f) below.

"I studied English for 16 years but...
...I finally learned to speak it in just six lessons"
Jane, Chinese architect

ENGLISH OUT THERE

Click to hear me talking before and after my unique course download



Sometimes it is convenient – but rarely a useful approach – to define the Taylor (or Maclaurin) expansions of functions, and then regard these as providing the definitions of the functions e.g. $e^z = 1 + z + \frac{1}{2!}z^2 + \dots$ (for all finite $|z|$). Here, we shall adopt a different (and, we submit, a far simpler and neater) approach to the definition of the functions that we commonly use; this becomes clear for the next function.

(c) Exponential function

The exponential function, $\exp(z) = e^z$, is defined by

$$e^z = e^{x+iy} = e^x e^{iy} = e^x (\cos y + i \sin y) (= u + iv),$$

which uses the familiar real functions (and the well-known Euler/de Moivre property). This recovers – of course! – the real-valued exponential function on $y = 0$, and both $\sin y$ and $\cos y$ on $x = 0$ (being the real and imaginary parts of the complex function evaluated on $x = 0$). For general z , the function exhibits both exponential and trigonometric properties; schematically, we have

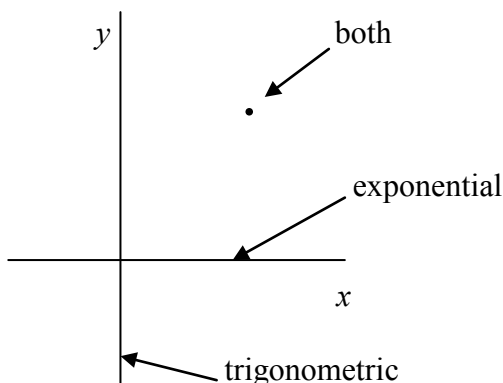

This function then exemplifies the close connection between the exponential and trigonometric functions (although, when first encountered in elementary mathematics, the impression is that they are very different functions). We now see that they are no more than different aspects of the same – elementary – function (e^z) when viewed in the complex plane. We add one further observation: from our definition, we see that

$$|e^z| = |e^x (\cos y + i \sin y)| = \sqrt{e^{2x} (\cos^2 y + \sin^2 y)} = e^x.$$

From this definition of e^z , we may explore problems that require a little care and subtlety in their solutions; we offer one in the next example.

Example 5 *Solution of equation.* Find all the solutions of $e^z = -1$.

We start from the definition: $e^z = e^x (\cos y + i \sin y) = -1$, and this requires

$$\sin y = 0 \text{ and } e^x \cos y = -1.$$

The first gives $y = n\pi$ ($n \in \mathbb{Z}$) and in the second, because $e^x > 0$, we must restrict the choice to $n = 1 + 2m$ ($m \in \mathbb{Z}$) i.e. only odd integers are allowed; then $x = 0$. Thus all solutions are given by

$$z = (1 + 2m)\pi i, \quad m \in \mathbb{Z}.$$

(This confirms the familiar result that $e^x < 0$ is impossible for $x \in \mathbb{R}$.)

The introduction of the exponential function then enables a raft of other functions to be defined.

(d) Functions related to the exponential function

From our definition of e^z in (c), we have

$$e^{iy} = \cos y + i \sin y \text{ and } e^{-iy} = \cos y - i \sin y$$

and so we may write

$$\cos y = \frac{1}{2}(e^{iy} + e^{-iy}) \text{ and } \sin y = \frac{1}{2i}(e^{iy} - e^{-iy})$$

(and these may be familiar results from elementary complex numbers; remember that y is real). We use the structure here to provide a *definition* of the trigonometric functions in the complex plane:

$$\sin z = \frac{1}{2i}(e^{iz} - e^{-iz}) \text{ and } \cos z = \frac{1}{2}(e^{iz} + e^{-iz}),$$

and note that it may be more convenient to write $1/2i = -i/2$. Correspondingly, we *define* the hyperbolic functions as

$$\sinh z = \frac{1}{2}(e^z - e^{-z}) \text{ and } \cosh z = \frac{1}{2}(e^z + e^{-z}),$$

and these agree with the familiar definitions (for real-valued functions) when we set $z = x$.

On the back of these definitions, some important identities connecting these four functions follow directly e.g. for real x we obtain

$$\sin(ix) = \frac{1}{2i}(e^{-x} - e^x) = \frac{1}{2}i(e^x - e^{-x}) = i \sinh x; \quad \cos(ix) = \frac{1}{2}(e^{-x} + e^x) = \cosh x.$$

This, in turn, enables us to expand (as for the sum of two angles) in terms of real and imaginary parts, as the next example demonstrates.

Example 6 *Real-imaginary form.* Express $\cosh(x + iy)$ in real-imaginary (Cartesian) form.

$$\begin{aligned} \text{We start from the definition of cosh: } \cosh(x + iy) &= \frac{1}{2} \left(e^{x+iy} + e^{-(x+iy)} \right) \\ &= \frac{1}{2} \left[e^x (\cos y + i \sin y) + e^{-x} (\cos y - i \sin y) \right] = \frac{1}{2} (e^x + e^{-x}) \cos y + \frac{1}{2} i (e^x - e^{-x}) \sin y \\ &= \cosh x \cos y + i \sinh x \sin y, \end{aligned}$$

which is the required identity.

We now turn to a consideration of the logarithmic function, and the complications that arise in this case.

(e) Logarithms

This discussion leads us into new waters, because the simple-minded extension from

the familiar real functions (as used, for example, for the exponential and trigonometric functions), when applied to the logarithmic function, is not possible. First, let us write $z = re^{i\theta}$, then we obtain the standard expression

Excellent Economics and Business programmes at:



university of
 groningen



**“The perfect start
 of a successful,
 international career.”**

CLICK HERE
 to discover why both socially
 and academically the University
 of Groningen is one of the best
 places for a student to be

www.rug.nl/feb/education

$$\log z = \ln r + i\theta,$$

and it is important to note what is written here. First, the logarithm of a complex-valued variable is ALWAYS written as 'log' (and the base is also always taken to be 'e'); the use of 'ln' has meaning only for real, positive quantities. So, what is the problem here?

We know that, for any z , we have $z = re^{i(\theta+2k\pi)}$; this does not affect the value (as a complex number) of z , but the polar form then corresponds to a non-unique representation of a unique z . Thus, when we introduce this into the expression for the logarithm, we obtain

$$\log z = \ln r + i(\theta + 2k\pi), \quad k \in \mathbb{Z},$$

which shows that the logarithm, in the complex plane, is *not unique*; this will have very significant consequences when we are faced with integrating functions such as $1/z$, which, we might expect, should be associated with $\log z$. So far as the function itself is concerned, it is usual to introduce (and use, when appropriate) a particular choice of the log value. We define the *principal value* as

$$\log z = \overset{PV}{\text{Log}} z = \ln r + i\Theta \quad (-\pi < \Theta \leq \pi),$$

where we have used the notation 'Log', and included explicit reference to the choice of the principal value ('PV'). The special value is based – not surprisingly – on a particular choice of the arg of the log function; the one we use here is the conventional choice, but any other is possible, providing that *full rotations in the Argand plane are avoided*. The choice here is equivalent to the restriction: do not cross the line $r > 0, \theta = -\pi$; this line is called a *branch cut*:

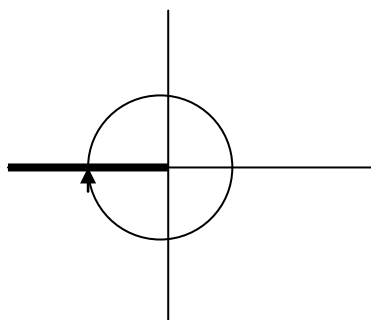

The effect of this definition is, across the branch cut (the heavy line in the figure), that Θ is discontinuous: it jumps from $+\pi$ to $-\pi$.

Example 7 *Logarithm.* Find $\log(-1)$.

First we write $-1 = e^{i(\pi+2n\pi)}$ with $n \in \mathbb{Z}$, and so

$$\log(-1) = \ln 1 + i(1+2n)\pi = i(1+2n)\pi.$$

This provides all the values of $\log(-1)$; if the principal value was required, then we have

$$\log(-1) = \overset{PV}{\text{Log}}(-1) = i\pi.$$

(f) General powers

Although we can use our development of the polynomial function, and the conventional rules of algebra, to define (and describe) what we mean by z^n , for $n \in \mathbb{Z}$, this does not help us to attach any meaning to z^α for arbitrary complex numbers α . To accomplish this, we make use of the exp and log functions – but then, of course, we will encounter non-uniqueness i.e. it is multi-valued! Thus we *define* z^α according to

$$z^\alpha = \exp(\alpha \log z),$$

and then the principal value as $z^\alpha = \overset{PV}{\exp}(\alpha \text{Log} z)$. We explore this idea in the next example.

Example 8 *Principal value.* Find the principal value of i^i .

We have

$$i^i = \overset{PV}{\exp}(i \text{Log} i)$$

where

$$\text{Log} i = \ln 1 + i\left(\frac{1}{2}\pi + 0\right) \text{ (because we select the arg to satisfy } -\pi < \arg \leq \pi \text{)}.$$

Thus we obtain $\text{Log} i = i\frac{1}{2}\pi$, and so $i^i = \overset{PV}{\exp}\left(i \cdot i\frac{1}{2}\pi\right) = e^{-\pi/2}$.

Comment: This is quite an intriguing answer – is it what you might have expected for the value of i^i ? (Note that all values of i^i are real, irrespective of the choice of arg.)

Exercises 2

10. Write these functions in real-imaginary form ($u + iv$), given that $z = x + iy$:

(a) ze^z ; (b) $z^2 - iz$; (c) $\bar{z}^2 - z^2$; (d) z/\bar{z} .

11. Express these functions in real-imaginary ($u + iv$) form, given that $z = x + iy$:

(a) $2z^3 - iz^2$; (b) $z \sin z$; (c) $z \cosh z$; (d) z^4 ; (e) $(1+z)/(1-z)$.

12. Find all the values of:

(a) $\log(i^{1/2})$; (b) $\text{Log}(-ei)$; (c) $\text{Log}(1-i)$; (d) $(1+i)^i$.

13. Find the principal value of each of these complex numbers:

(a) $(1+i)^i$; (b) 2^i ; (c) $(1-i)^{4i}$.

14. Show that $e^z \neq 0$ for all z .

15. Find all the roots of these equations:

(a) $e^z = -3$; (b) $\log z = \frac{1}{2}i\pi$; (c) $\sin z = 2$; (d) $\cosh z = -1$.

16. Find all the solutions of these equations: (a) $\sinh z = 0$; (b) $\cosh z = 0$.

17. Find all the solutions of the equation $\sinh z = k \cosh z$, where $k > 0$ is a real constant. Discuss the three cases: (a) $0 < k < 1$; (b) $k = 1$; (c) $k > 1$.

18. Express these functions in real-imaginary form, given that both x and y are real, starting from the definitions in terms of the exponential function:

(a) $\sin(x + iy)$; (b) $\cos(x + iy)$; (c) $\sinh(x + iy)$; (d) $\cosh(x + iy)$, and, using earlier results: (e) $\tan(x + iy)$; (f) $\tanh(x + iy)$.

Confirm that the expression for $\tan x$ recovers the familiar result; what are the corresponding expression for $\tan(ix)$ and $\tanh(ix)$?

19. The *gamma function* is defined as $\Gamma(z) = \int_0^\infty t^{z-1} e^{-t} dt$. Use integration by parts to show that $\Gamma(1+z) = z\Gamma(z)$, with $\Gamma(1) = 1$, and hence, for n integer, that $\Gamma(1+n) = n!$ Also obtain the values of (a) $\Gamma(1/2)$; (b) $\Gamma(3/2)$; (c) $\Gamma(-1/2)$.

[You may use the identity: $\int_0^\infty e^{-x^2} dx = \frac{1}{2}\sqrt{\pi}$.]

3 Differentiability

We now turn to a fundamental question, with far-reaching consequences: what is the derivative of a function of a complex variable? As we shall see, viewed one way round, the answer is no surprise – it is exactly what we would expect based on our knowledge of conventional differentiation – but another way round, it introduces ideas that are altogether unforeseen.

Before we initiate this particular investigation, we first invoke the requirement that our functions are certainly to be continuous (at least, in some neighbourhood of the point of interest) i.e.

$$\lim_{\zeta \rightarrow 0} [f(z + \zeta)] = f(z),$$

where $\zeta \in \mathbb{C}$. Thus the approach to the point in question can be from any (and every) direction in the complex plane; it is this qualification that will eventually lead to some important conditions.

3.1 Definition

Given a complex function, f , of the complex variable, z (so that $f(z) \in \mathbb{C}$, $z \in \mathbb{C}$), then we define the derivative in the familiar way:

$$\lim_{\zeta \rightarrow 0} \left[\frac{f(z + \zeta) - f(z)}{\zeta} \right] \left(\equiv \frac{df}{dz} \text{ or } f'(z) \right),$$

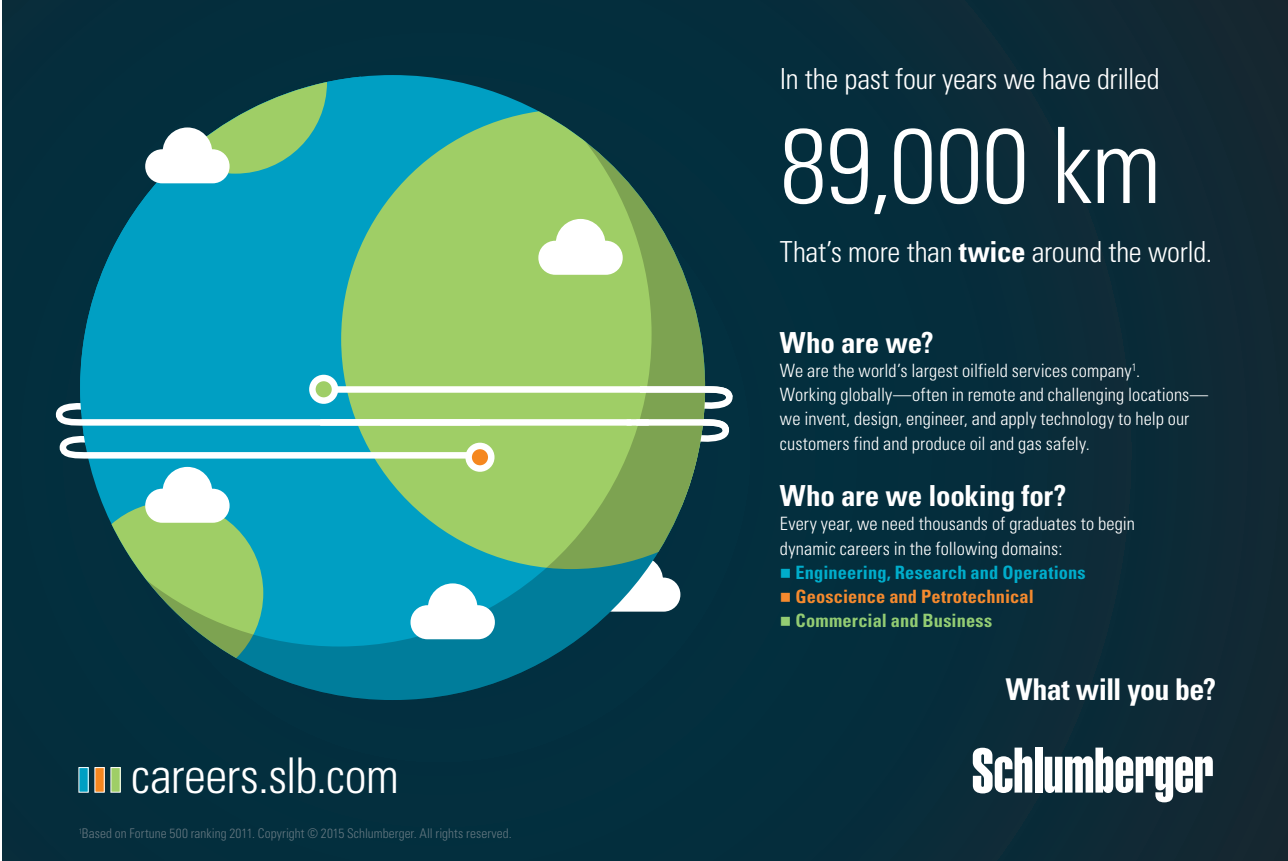

In the past four years we have drilled

89,000 km

That's more than **twice** around the world.

Who are we?
We are the world's largest oilfield services company¹. Working globally—often in remote and challenging locations—we invent, design, engineer, and apply technology to help our customers find and produce oil and gas safely.

Who are we looking for?
Every year, we need thousands of graduates to begin dynamic careers in the following domains:

- Engineering, Research and Operations
- Geoscience and Petrotechnical
- Commercial and Business

What will you be?

careers.slb.com

Schlumberger

¹Based on Fortune 500 ranking 2011. Copyright © 2015 Schlumberger. All rights reserved.

Click on the ad to read more

where $\zeta \in \mathbb{C}$, provided that this limit exists and that it is *independent of the direction* in which z is approached. We write $\zeta = h + ik$, and then the ratio h/k , as both h and k tend to zero, determines the direction from which the point z is approached as the limit is performed. (We continue to use all the familiar notation for derivatives i.e. df/dz and $f'(z)$, as well as $\partial u/\partial x$ and u_x .)

It is informative to compare this description with the situation that pertains for the derivative of real functions, familiar from any studies of elementary calculus:

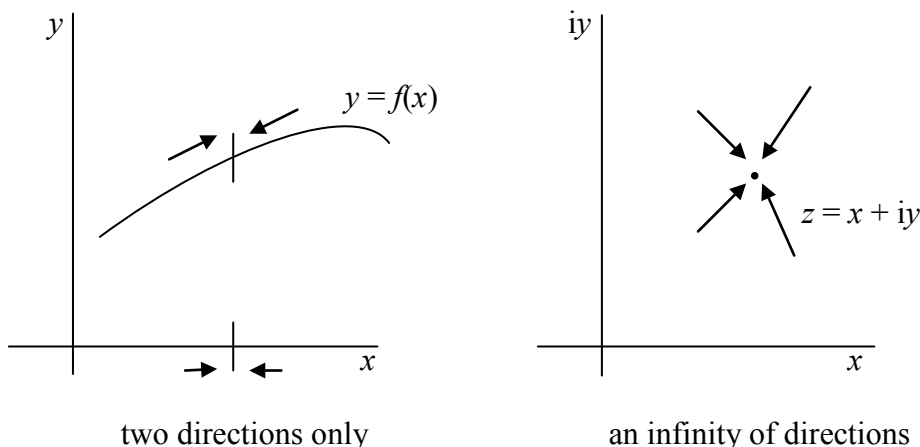

The limit process, for real functions, involves just two directions: the point on the curve is approached from the left and from the right. But in the complex plane, we may approach from *any* direction. For the definition of the derivative for real functions, it is necessary that the two limits give the same result (and exist, of course); then we say that the function is differentiable at this point. The same philosophy applies to the derivative of the function of a complex variable, but now the limit must give the same result from *all possible* directions. Viewed like this, it is not surprising that this imposes a very significant constraint in order to make differentiability possible.

Once we have this notion of a derivative in place, all the familiar rules for differentiation follow directly. However, before we investigate, in detail, the consequences of this definition, let us look at a simple example.

Example 9 *Derivative defined?* Find the derivative of $f = y + ix$ at the point $(1, 1)$ by working from two directions.

We choose to take the limit, first keeping y fixed and then, separately, keeping x fixed. So in the first case, we obtain

$$\lim_{h \rightarrow 0} \left(\frac{1 + i(1+h) - (1+i)}{h} \right) = i$$

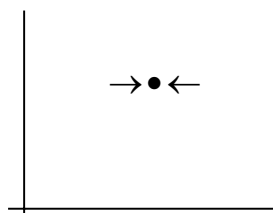

and in the second we have $\lim_{k \rightarrow 0} \left(\frac{1+k+i-(1+i)}{ik} \right) = -i$.

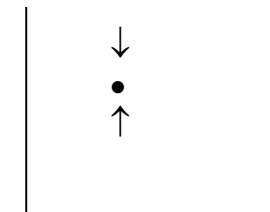

Thus, in this example, the derivative is *not defined* because it is *not unique*.

On the other hand, if we start with a specific function of z , and then apply the definition, we find that the derivative follows in the usual fashion.

Example 10 *Derivative (first principles).* Find the derivative of z^2 from first principles.

We form
$$\frac{df}{dz} = \lim_{\zeta \rightarrow 0} \left[\frac{(z+\zeta)^2 - z^2}{\zeta} \right] = \lim_{\zeta \rightarrow 0} \left[\frac{2z\zeta + \zeta^2}{\zeta} \right] = 2z,$$

which is the expected result for this derivative (based our experience with the differentiation of real functions).

3.2 The derivative in detail

We now find the conditions – and there are two – which ensure that $f = u + iv$ has a unique derivative at a point in the complex plane. This calculation proceeds in three stages: first we find *two necessary conditions*, and then we construct a *sufficiency argument*. We set

$$f = u(x, y) + iv(x, y),$$

and assume that all first partial derivatives exist (at least, in some domain around the general point $z = x + iy$); the limit that is the basis for the derivative will be (as outlined above) taken as $\zeta = h + ik \rightarrow 0$. However, we start with two special interpretations of this (cf. Example 9):

- a) $h \rightarrow 0$ for $k = 0$;
- b) $k \rightarrow 0$ for $h = 0$,

which will generate our two necessary conditions.

(a) $h \rightarrow 0$ for $k = 0$

With this choice, we construct

$$\lim_{h \rightarrow 0} \left[\frac{u(x+h, y) + iv(x+h, y) - \{u(x, y) + iv(x, y)\}}{h} \right]$$

$$= \frac{\partial u}{\partial x} + i \frac{\partial v}{\partial x},$$

which is one version of the expression for the derivative at $z = x + iy$.

(b) $k \rightarrow 0$ for $h = 0$

Conversely, here, we construct the alternative version of the limit

$$\lim_{k \rightarrow 0} \left[\frac{u(x, y+k) + iv(x, y+k) - \{u(x, y) + iv(x, y)\}}{ik} \right]$$

$$= -i \frac{\partial u}{\partial y} + \frac{\partial v}{\partial y}$$

These two results are two (different) answers for the derivative at a point; for these to be the *same* – an essential requirement for *uniqueness* – then we must have

American online

LIGS University

is currently enrolling in the
Interactive Online **BBA, MBA, MSc,**
DBA and PhD programs:

- ▶ enroll **by September 30th, 2014** and
- ▶ **save up to 16%** on the tuition!
- ▶ pay in 10 installments / 2 years
- ▶ Interactive **Online education**
- ▶ visit www.ligsuniversity.com to find out more!

Note: LIGS University is not accredited by any nationally recognized accrediting agency listed by the US Secretary of Education. More info [here](#).





$$\frac{\partial u}{\partial x} = \frac{\partial v}{\partial y} \text{ and } \frac{\partial u}{\partial y} = -\frac{\partial v}{\partial x}.$$

These constitute *necessary conditions* for a unique derivative at a point. However, perhaps, as we take any other direction (by fixing the ratio h/k , as the limit is taken), we produce another answer, and so on. That this is *not* the case is what we shall now demonstrate; what follows is the sufficiency argument (based on the simplest ideas that come from the assumed existence of a Taylor expansion). More complete proofs, using the deeper ideas of functional analysis, are available (but beyond the scope of this text).

(c) Sufficiency

This time we consider the full, general limit problem:

$$\lim_{h+ik \rightarrow 0} \left[\frac{u(x+h, y+k) + iv(x+h, y+k) - \{u(x, y) + iv(x, y)\}}{h+ik} \right],$$

and because first partial derivatives exist, we may approximate the functions near to $z = x + iy$ i.e. for small $\zeta = h + ik$, by using Taylor expansions (and so we require, in addition, that the first partial derivatives are continuous). Thus we obtain

$$\lim_{h+ik \rightarrow 0} \left[\frac{u + hu_x + ku_y + \Delta + i(v + hv_x + kv_y + \delta) - \{u + iv\}}{h+ik} \right],$$

where, for simplicity, we have suppressed the arguments, (x, y) , of all the functions; Δ and δ are the error terms in the Taylor expansions associated with the expansions of u and v , respectively. Because first partial derivatives do exist, these are small correction terms in the limit, so we must have

$$\lim_{h+ik \rightarrow 0} \left(\frac{\Delta + i\delta}{h+ik} \right) = 0.$$

The necessary conditions are now used (e.g. replacing v_x by $-u_y$, and v_y by u_x) to give

$$\begin{aligned} & \lim_{h+ik \rightarrow 0} \left[\frac{h(u_x - iu_y) + ik(u_x - iu_y) + \Delta + i\delta}{h+ik} \right] \\ &= \lim_{h+ik \rightarrow 0} \left[\frac{(h+ik)u_x - i(h+ik)u_y + \Delta + i\delta}{h+ik} \right] = u_x - iu_y \end{aligned}$$

for all $\zeta = h + ik \rightarrow 0$. Thus for $f = u + iv$ to be differentiable, we require

$$\frac{\partial u}{\partial x} = \frac{\partial v}{\partial y} \text{ and } \frac{\partial u}{\partial y} = -\frac{\partial v}{\partial x},$$

which are known as the *Cauchy-Riemann (CR) relations*.

Comment: Here is an important observation; let us consider

$$u(x, y) + iv(x, y) = f(z, \bar{z}) = f(x + iy, x - iy),$$

which is, in principle, always algebraically possible; see Example 4. As before, we assume that all first partial derivatives exist, then we take $\partial/\partial x$ and, separately, $\partial/\partial y$, of this equation:

$$u_x + iv_x = f_z + f_{\bar{z}} \quad \text{and} \quad u_y + iv_y = if_z - if_{\bar{z}},$$

respectively. We now impose the CR relations, and this pair then becomes

$$u_x - iv_y = f_z + f_{\bar{z}} \quad \text{and} \quad u_y + iv_x = i(f_z - f_{\bar{z}}) \quad \text{or} \quad -iv_y + u_x = f_z - f_{\bar{z}},$$

and the first and third equations give, directly, $2f_{\bar{z}} = 0$: so f is *not a function* of \bar{z} . Thus the CR relations guarantee that $u(x, y) + iv(x, y) = f(z)$, and also that this function is differentiable. Indeed we see that, by taking $\partial/\partial x$ (or we could elect to take $\partial/\partial y$; this is left for the reader to check), we obtain

$$\frac{\partial f}{\partial x} = \frac{df}{dz} \frac{\partial z}{\partial x} = \frac{\partial}{\partial x}(u + iv) \quad \text{i.e.} \quad \frac{df}{dz} = u_x + iv_x,$$

which is one our results for the derivative (obtained from first principles). Further, the derivative of f is the conventional and familiar derivative, when expressed as a function of the single variable z .

Example 11 *Derivative.* Use the definition of e^z , and the Cauchy-Riemann relations, to confirm that $(d/dz)e^{\alpha z} = \alpha e^{\alpha z}$ (α a real constant).

We write

$$\begin{aligned} e^{\alpha z} &= e^{\alpha(x+iy)} = e^{\alpha x}(\cos \alpha y + i \sin \alpha y) \quad (\text{since } \alpha \text{ is real}) \\ &= u(x, y) + iv(x, y) \end{aligned}$$

which gives $u_x = \alpha e^{\alpha x} \cos \alpha y$ ($= v_y$) and $v_x = \alpha e^{\alpha x} \sin \alpha y$ ($= -u_y$).

One version of the derivative (see above) is therefore

$$\begin{aligned} u_x + iv_x &= \alpha e^{\alpha x}(\cos \alpha y + i \sin \alpha y) \\ &= \alpha e^{\alpha z} \quad (\text{as required}). \end{aligned}$$

(It is left as an exercise to show that this same result is obtained, using this same approach, when α is a general (complex) constant.)

As we now demonstrate, the CR relations can also be used to find either u or v , given one of them – provided that the given function is ‘appropriate’.

Example 12 CR relations. Given $u(x, y) = 2xy + 3e^{-x} \cos y$, find $f(z) = u + iv$.

From the given $u(x, y)$ we obtain

$$u_x = 2y - 3e^{-x} \cos y = v_y \text{ and } u_y = 2x - 3e^{-x} \sin y = -v_x$$

and integrating each of these, we find expressions for $v(x, y)$:

$$v = y^2 - 3e^{-x} \sin y + F(x) \text{ and } v = -x^2 - 3e^{-x} \sin y + G(y), \text{ respectively.}$$

Now these two are consistent when we choose $F(x) = -x^2 + A$ and $G(y) = y^2 + A$, where A is an arbitrary constant; thus

$$v = y^2 - x^2 - 3e^{-x} \sin y + A.$$

We form $u + iv = 2xy + 3e^{-x} \cos y + i(y^2 - x^2 - 3e^{-x} \sin y + A)$

.....Alcatel-Lucent 

www.alcatel-lucent.com/careers

What if you could build your future and create the future?

One generation's transformation is the next's status quo. In the near future, people may soon think it's strange that devices ever had to be "plugged in." To obtain that status, there needs to be "The Shift".

 [Click on the ad to read more](#)

$$\begin{aligned}
 &= -i(x^2 - y^2 + 2ixy) + 3e^{-x}(\cos y - i \sin y) + iA \\
 &= -iz^2 + 3e^{-z} + iA
 \end{aligned}$$

which is the required $f(z) = u + iv$ (defined to within an arbitrary (imaginary) constant).

We have demonstrated that a differentiable function of a complex variable is just that: a function of the single variable z . We investigate this property a little further by working through the next example.

Example 13 *Differentiable?* Show that $f = \bar{z}$ is not differentiable.

Here we have $f = u + iv = x - iy$, so that

$$u_x = 1, u_y = 0, v_x = 0, v_y = -1;$$

thus $u_y = -v_x (= 0)$, but $u_x \neq v_y$: the CR relations are not satisfied (anywhere), and so the given function is not differentiable.

Finally, we may use all the ideas introduced so far to produce more derivatives.

Example 14 *Derivatives.* Use the derivative of $e^{\alpha z}$ (for α a general complex constant) to find the derivatives of $\sin z$ and $\cosh z$.

Given $\sin z = \frac{1}{2i}(e^{iz} - e^{-iz})$, then

$$\frac{d}{dz}(\sin z) = \frac{1}{2i}(ie^{iz} + ie^{-iz}) = \frac{1}{2}(e^{iz} + e^{-iz}) = \cos z,$$

which is the familiar result. Correspondingly, with $\cosh z = \frac{1}{2}(e^z + e^{-z})$, we have

$$\frac{d}{dz}(\cosh z) = \frac{1}{2}(e^z - e^{-z}) = \sinh z.$$

3.3 Analyticity

We now introduce an important idea in the theory of complex functions, which is based on this fundamental definition:

If $f(z)$ exists at $z = z_0$, and in a neighbourhood of $z = z_0$, and if $f'(z_0)$ is defined, then $f(z)$ is said to be *analytic* (or *regular* or *holomorphic*) at $z = z_0$.

The most commonly-used terminology is ‘analytic’ (which is the one we will use most often), but ‘regular’ is also used and, sometimes, the more technical ‘holomorphic’ (which is constructed from the Greek words for ‘whole’ + ‘form’ so ‘complete description’ i.e. it tells you all that you need to know).

Such a function, at least in this neighbourhood (‘nbhd’), is then called an *analytic function*: it exists and is differentiable at $z = z_0$. Such a function necessarily satisfies the Cauchy-Riemann relations at (and usually in a nbhd of) this point, because the CR relations imply both existence and differentiability.

Finally, we often come across functions that are analytic everywhere in the complex plane; such a function is called an *entire function*: it is defined (and is differentiable) throughout the *entire* complex plane.

Example 15 *Entire function.* Show that $f = e^x(\cos y + i \sin y)$ is an entire function, but that $f = e^x(\cos y - i \sin y)$ is not.

First, we note that e^x , $\sin y$ and $\cos y$ all exist throughout the 2D plane i.e. for finite x and y , so both functions exist. However, to be differentiable in the complex plane, the CR relations must hold; for the first function, with

$$u = e^x \cos y \text{ and } v = e^x \sin y,$$

we obtain $u_x = e^x \cos y$, $u_y = -e^x \sin y$, $v_x = e^x \sin y$, $v_y = e^x \cos y$,

and so $u_x = v_y$ and $u_y = -v_x$ everywhere: the first function is *entire*.

For the second function, we obtain

$$u_x = e^x \cos y, u_y = -e^x \sin y, v_x = -e^x \sin y, v_y = -e^x \cos y;$$

the CR relations then require $\cos y = 0$ and $\sin y = 0$, which is impossible: this function is not analytic anywhere.

In this example, we see that the first function is simply $f(z) = e^z$, but the second is $f = e^{\bar{z}}$, which is not a function of z (and so the CR relations are not applicable).

3.4 Harmonic functions

Here, we present an important consequence of the CR relations (on the assumption that our functions u and v are now twice differentiable). Consider the CR relations, and suitably differentiate them:

$$u_x = v_y \text{ and then form } u_{xy} = v_{yy}; \text{ similarly } u_y = -v_x \text{ gives } u_{yx} = -v_{xx}$$

and so $v_{xx} + v_{yy} = 0$.

Correspondingly, also from the CR relations, we obtain

$$v_{xy} = u_{xx} \text{ and } v_{yx} = -u_{yy}, \text{ and so } u_{xx} + u_{yy} = 0.$$

Thus both u and v satisfy the (two dimensional) Laplace's equation; this equation is important, for example, in the study of fluid mechanics, of electric and magnetic fields, of steady temperatures and of gravity fields. Typically, these problems require that we

find $\phi(x, y)$ such that $\phi_{xx} + \phi_{yy} = 0$ with ϕ given on the boundary of a region.

Any solution of Laplace's equation is usually called a *harmonic function*, and u and v together constitute *conjugate harmonic functions*. The property that we have just described provides the basis for generating solutions of Laplace's equation in a very simple way: write down any $f(z)$, separate into real and imaginary parts, then the two resulting functions are necessarily solutions of Laplace's equation. (Although this is constructively a very simple and, in a sense, a powerful method, it is not suitable if a specific problem, with specific boundary conditions, is to be solved.)



Join the best at
the Maastricht University
School of Business and
Economics!

Top master's programmes

- 33rd place Financial Times worldwide ranking: MSc International Business
- 1st place: MSc International Business
- 1st place: MSc Financial Economics
- 2nd place: MSc Management of Learning
- 2nd place: MSc Economics
- 2nd place: MSc Econometrics and Operations Research
- 2nd place: MSc Global Supply Chain Management and Change

Sources: Keuzegids Master ranking 2013; Elsevier 'Beste Studies' ranking 2012; Financial Times Global Masters in Management ranking 2012

Maastricht University is the best specialist university in the Netherlands (Elsevier)

Visit us and find out why we are the best!
Master's Open Day: 22 February 2014

www.mastersopenday.nl



Click on the ad to read more

Example 16 Laplace's equation. Use $f(z) = z \sin z$ to construct solutions of Laplace's equation.

We write $f(z) = z \sin z = (x + iy) \sin(x + iy)$

$$= (x + iy)(\sin x \cosh y + i \cos x \sinh y)$$

$$= x \sin x \cosh y - y \cos x \sinh y + i(y \sin x \cosh y + x \cos x \sinh y),$$

and so two solutions of Laplace's equation are

$$u = x \sin x \cosh y - y \cos x \sinh y, \quad v = y \sin x \cosh y + x \cos x \sinh y.$$

(These can be checked by direct substitution, if so desired.)

Comment: In all the descriptions and developments so far, we have used only rectangular Cartesian coordinates – and this is usually the choice that we make. However, all the usual results (and the CR relations in particular) can be expressed in polar coordinates. Given the familiar transformation: $x = r \cos \theta$, $y = r \sin \theta$, then we may form

$$\frac{\partial u}{\partial \theta} = \frac{\partial u}{\partial x} \frac{\partial x}{\partial \theta} + \frac{\partial u}{\partial y} \frac{\partial y}{\partial \theta} = -r \sin \theta \frac{\partial u}{\partial x} + r \cos \theta \frac{\partial u}{\partial y}$$

and, correspondingly, $\frac{\partial u}{\partial r} = \cos \theta \frac{\partial u}{\partial x} + \sin \theta \frac{\partial u}{\partial y}$;

similar results are then obtained for v_θ and v_r :

$$\frac{\partial v}{\partial r} = \cos \theta \frac{\partial v}{\partial x} + \sin \theta \frac{\partial v}{\partial y}, \quad \frac{\partial v}{\partial \theta} = -r \sin \theta \frac{\partial v}{\partial x} + r \cos \theta \frac{\partial v}{\partial y}.$$

These four relations (written now with subscripts for partial derivatives) then give

$$ru_x = (r \cos \theta)u_r - (\sin \theta)u_\theta, \quad ru_y = (r \sin \theta)u_r + (\cos \theta)u_\theta$$

and

$$rv_x = (r \cos \theta)v_r - (\sin \theta)v_\theta, \quad rv_y = (r \sin \theta)v_r + (\cos \theta)v_\theta;$$

the CR relations (written in Cartesians) are therefore equivalent to the pair

$$(r \cos \theta) \left(u_r - \frac{1}{r} v_\theta \right) - (r \sin \theta) \left(v_r + \frac{1}{r} u_\theta \right) = 0$$

and

$$(r \sin \theta) \left(u_r - \frac{1}{r} v_\theta \right) - (r \cos \theta) \left(v_r + \frac{1}{r} u_\theta \right) = 0.$$

Thus we obtain
$$u_r = \frac{1}{r}v_\theta \text{ and } \frac{1}{r}u_\theta = -v_r \text{ (} r \neq 0 \text{),}$$

which are the CR relations written in polar coordinates. It is instructive to observe that the form of these two relations follows the pattern of the original CR relations, in that $\partial/\partial x \rightarrow \partial/\partial r$ and $\partial/\partial y \rightarrow r^{-1}\partial/\partial\theta$.

It is left as an exercise, for the interested and committed reader, to derive this version of the CR relations directly from the polar form. That is, given

$$f(z) = f(re^{i\theta}) = u(r, \theta) + iv(r, \theta),$$

find the derivative of $f(z)$ by considering the two limits, separately, in which only r changes or only θ changes, and equate the two results. You may then show that

$$f'(z) = e^{-i\theta}(u_r + iv_r) = r^{-1}e^{-i\theta}(v_\theta - iu_\theta).$$

Example 17 *Polar form of CR relations.* Use the polar form of the Cauchy-Riemann relations to show that $f(z) = \log z$ is an analytic function for all $z \neq 0$.

First we set $z = re^{i\theta}$, where we must ensure that the function is continuous, so we elect to use $-\pi < \theta < \pi$ (because the function will not be differentiable at the discontinuity); indeed, we may choose to use *any* branch e.g. $\theta_0 - \pi < \theta < \theta_0 + \pi$, for any θ_0 ; then

$$f(z) = \log z = \ln r + i\theta \text{ i.e. } u(r, \theta) = \ln r, \quad v(r, \theta) = \theta.$$

Thus
$$u_r = 1/r, \quad v_\theta = 1; \quad u_\theta = 0, \quad v_r = 0,$$

and so the CR relations are satisfied everywhere throughout the plane, except at the origin (where f and the CR relations are not defined) and on each branch cut.

Note: This example shows that, away from the origin, the CR relations are satisfied (for any given choice of the arg), even though this function is multi-valued. Indeed, we can extend this calculation to obtain the derivative of the log function in the complex plane: write $\log z = f(z) = f(re^{i\theta}) = u + iv$, for any θ as above, and then take, for example, $\partial/\partial r$ of this definition, to give

$$e^{i\theta} f'(re^{i\theta}) = e^{i\theta} f'(z) = u_r + iv_r = \frac{1}{r},$$

where the last term here is obtained from the work in Example 17. Thus we see that we may write

$$f'(z) = \frac{1}{re^{i\theta}} = \frac{1}{z},$$

which confirms that the derivative of $\log z$ is the familiar $1/z$, for any choice of the arg. (The change of arg amounts to an additive constant in the representation of $\log z$, and differentiation removes this: in part, the result here is therefore no surprise.)

Exercises 3

20. Which of these are analytic functions (for x and y real)? Of course, this means that you must check if the Cauchy-Riemann relations hold in some neighbourhood of the complex plane.
- (a) $e^{-x}(\cos y - i \sin y)$; (b) x ; (c) $e^x(\sin y + i \cos y)$; (d) $x^2 + iy^2$; (e) $2x + ixy^2$; (f) $2 - y + ix$; (g) $e^y(\cos x + i \sin x)$.

21. Given these functions, $u(x, y)$, determine (wherever possible) $f(z) = u + iv$:

- (a) $2x(1 - y)$; (b) $2x - x^3 + 3xy^2$; (c) x^2 ; (d) ye^x ; (e) xy ; (f) $y - x$; (g) $y^2 - x^2$.

22. Show that these functions are NOT complex-differentiable i.e. the Cauchy-Riemann relations are not satisfied in any neighbourhood of the complex plane:

- (a) $\Re(z)$; (b) $|z|$; (c) \bar{z}^2 .

23. Given that $f(z) = u + iv$ is an analytic function, show that

$$\frac{\partial u}{\partial x} \frac{\partial v}{\partial x} + \frac{\partial u}{\partial y} \frac{\partial v}{\partial y} = 0,$$

and then that lines of constant u , and constant v , are orthogonal.

Use this result to show that lines of constant $|f|$, and lines of constant $\arg(f)$, are orthogonal. [Hint: consider the function $\text{Log}(f)$, so avoiding the branch cut, which is necessary for an analytic function.]

24. From the definitions in terms of exponential functions, use the derivative of $e^{\alpha z}$ to find the derivatives of

- (a) $\cos z$; (b) $\sinh z$.

25. Find pairs of solutions of Laplace's equation, $\frac{\partial^2 \phi}{\partial x^2} + \frac{\partial^2 \phi}{\partial y^2} = 0$, based on these complex functions:

- (a) ze^{2z} ; (b) z^4 ; (c) $z^2 \sin z$; (d) $e^z \cos z$.

4 Integration in the complex plane

In this chapter we address the very important issue, with far-reaching consequences, of what we mean by integration in the complex plane. This requires us to start from the familiar (real) line integral, suitably written to describe the integration along a path in the complex plane. This then leads, quite naturally, to the notion of a contour integral in the complex plane. Once this is done, we can construct the various theorems – which take a particularly simple form – that enable this integration to be performed altogether routinely (avoiding the usual techniques of integration which are familiar from more elementary mathematics).

4.1 The line integral

Integration in the complex plane, from one point to another (let us suppose from A to B), is necessarily a *line integral*:

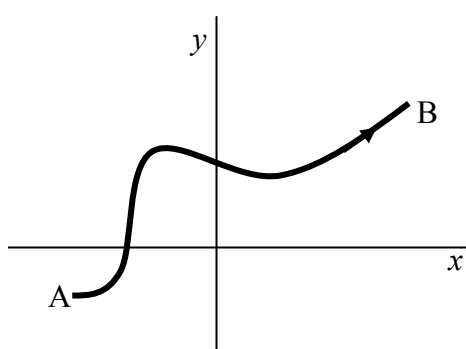

> Apply now

REDEFINE YOUR FUTURE
**AXA GLOBAL GRADUATE
PROGRAM 2015**

redefining / standards 

agence c4g © Photonstop

(It is instructive to compare this with the conventional real integral, which is solely along the real line.) In order to interpret, and suitably define, this line integral, we introduce a real parameter, t , and consider first $g(t) = u(t) + iv(t)$ for $a \leq t \leq b$; we have written this function in real-imaginary form. Then we construct

$$\begin{aligned} \int_a^b g(t) dt &= \int_a^b [u(t) + iv(t)] dt \\ &= \int_a^b u(t) dt + i \int_a^b v(t) dt, \end{aligned}$$

by invoking the linearity of the integral operator i.e. the integral of a sum is the sum of the integrals (and noting that 'i' is a constant independent of t).

Example 18 *Line integral I.* Evaluate $\int_0^1 (t + it^2)^2 dt$.

We have

$$\begin{aligned} (t + it^2)^2 &= t^2 - t^4 + 2it^3 \\ \text{and so} \quad \int_0^1 (t + it^2)^2 dt &= \int_0^1 (t^2 - t^4) dt + i \int_0^1 2t^3 dt = \left[\frac{1}{3}t^3 - \frac{1}{5}t^5 \right]_0^1 + i \left[\frac{1}{2}t^4 \right]_0^1 \\ &= \frac{1}{3} - \frac{1}{5} + i \frac{1}{2} = \frac{2}{15} + \frac{1}{2}i. \end{aligned}$$

It is usual to refer to a line integral in the complex plane as a *contour integral*.

We now extend this simple idea by considering a general function defined in the (x, y) -plane. Let us suppose that we have a complex-valued function, $f(x, y)$ (not necessarily, at this stage, a function of z), that we integrate along a path/contour C which is represented by $z = \gamma(t)$, $a \leq t \leq b$ (where t is a real parameter that maps out C). Following the development above, we define the line integral in the complex plane by using the familiar rule for the change of variable:

$$\int_C f(x, y) dz = \int_a^b f[x(t), y(t)] \frac{d\gamma}{dt} dt.$$

Example 19 *Line integral II.* Evaluate $\int_C (x^2 + iy^2) dz$ along the path:

(a) $z = t + it$, $0 \leq t \leq 1$; (b) $z = t$, $0 \leq t \leq 1$, followed by $z = 1 + it$, $0 \leq t \leq 1$.

(c) On this path, we have $x = t$, $y = t$ and $\frac{dz}{dt} = \frac{d\gamma}{dt} = 1 + i$; the integral becomes

$$\int_0^1 (t^2 + it^2)(1 + i) dt = (1 + i)^2 \left[\frac{1}{3} t^3 \right]_0^1$$

$$= \frac{1}{3}(1 + 2i - 1) = \frac{2}{3}i.$$

(b) On the first part of the given path, we have $x = t$, $y = 0$ and $\frac{d\gamma}{dt} = 1$, and so we obtain $\int_0^1 t^2 \cdot 1 dt = \frac{1}{3}$.

On the second part of the path, $x = 1$, $y = t$ and $\frac{d\gamma}{dt} = i$; so we now have

$$\int_0^1 (1 + it^2) \cdot i dt = \left[it - \frac{1}{3} t^3 \right]_0^1 = i - \frac{1}{3}.$$

Thus the integral along the whole path becomes

$$\int_C (x^2 + iy^2) dz = \frac{1}{3} + i - \frac{1}{3} = i.$$

We observe that, in this example, the two line integrals are of the same function, but on different paths between the *same* points:

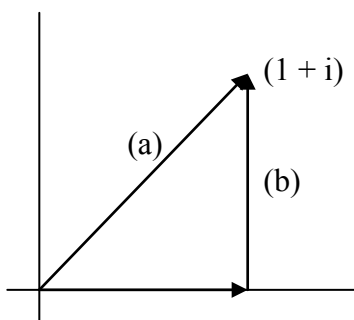

The values of the two path-integrals are different, so the line integral in this example is *path-dependent*. Here, the function being integrated, $f = x^2 + iy^2$ along the path, cannot be expressed as a function of z alone; the interested reader should check the CR relations for this function.

4.2 The fundamental theorem of calculus

We are now in a position to turn to the type of function of most interest and relevance to us, namely $f(z)$, where f is analytic on the path $C: z = \gamma(t), a \leq t \leq b$. Further, we make the simplifying assumption that we can express $f(z)$ as the derivative of a function i.e. $f(z) = \frac{dF}{dz}$, then on the path (using our definitions above) we have

$$\int_C f(z) dz = \int_a^b f[\gamma(t)]\gamma'(t) dt = \int_a^b F'[\gamma(t)]\gamma'(t) dt$$

$$= \int_a^b \frac{d}{dt} \{F[\gamma(t)]\} dt = [F[\gamma(t)]]_a^b = F[\gamma(b)] - F[\gamma(a)]$$

which is the fundamental theorem of calculus i.e. differentiation and integration are inverse operations (first published within the familiar calculus by Leibniz in 1675). Further, we see that the value of the integral is *path-independent*: the value depends only on the end-points, denoted here by $z = \gamma(a), \gamma(b)$. We note, however, that this result does require $F(z)$ to be analytic, and so defined (and unique), and differentiable, on γ .

Example 20 *Contour integral I.* Find the value of $\int_C z^2 dz$ from $z = 0$ to $z = 1 + i$.



Empowering People. Improving Business.

BI Norwegian Business School is one of Europe's largest business schools welcoming more than 20,000 students. Our programmes provide a stimulating and multi-cultural learning environment with an international outlook ultimately providing students with professional skills to meet the increasing needs of businesses.

BI offers four different two-year, full-time Master of Science (MSc) programmes that are taught entirely in English and have been designed to provide professional skills to meet the increasing need of businesses. The MSc programmes provide a stimulating and multi-cultural learning environment to give you the best platform to launch into your career.

- MSc in Business
- MSc in Financial Economics
- MSc in Strategic Marketing Management
- MSc in Leadership and Organisational Psychology

www.bi.edu/master

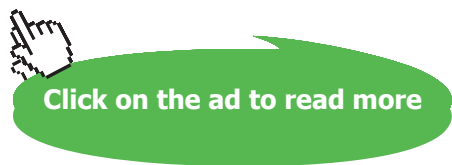

We have simply that

$$\begin{aligned}\int_C z^2 dz &= \int_0^{1+i} z^2 dz = \left[\frac{1}{3} z^3 \right]_0^{1+i} = \frac{1}{3} (1+i)^3 \\ &= \frac{1}{3} (1+3i-3-i) = \frac{2}{3} (-1+i).\end{aligned}$$

4.3 Closed contours

We now investigate an important class of contours, which sit at the heart of the fundamental theorems on integration in the complex plane; these are closed contours. First, a simple definition: a contour $C: z = \gamma(t)$, $a \leq t \leq b$, for which $\gamma(a) = \gamma(b)$, $b > a$, is called a *closed contour*.

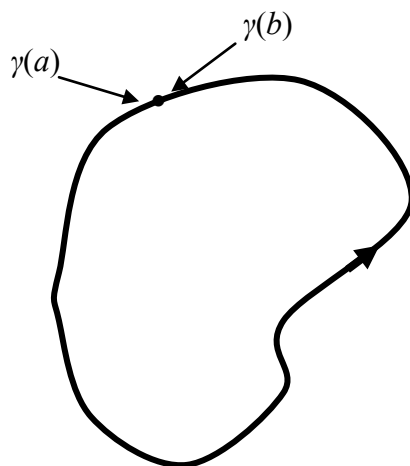

In this figure, we have drawn a simple, closed curve – a *Jordan curve* (which should be a familiar object from any studies at an early stage in university mathematics); in this case, we usually write

$$\oint_C f(z) dz,$$

where we have added a circle notation to the integral sign (which also may be familiar). Now suppose that $f(z)$ is analytic along C , and that $f(z) = F'(z)$ (as described above), then the fundamental theorem gives

$$\oint_C f(z) dz = \oint_C F'(z) dz = [F(z)]_{\gamma(a)}^{\gamma(b)} = F[\gamma(b)] - F[\gamma(a)] = 0$$

if $F(z)$ is also analytic and continuous on C . (If it happens that $F(z)$ is not continuous along the path, then the value of the integral will, in general, include a non-zero contribution from the jump in value.)

Example 21 *Contour integral II.* Find $\oint_C \frac{1}{z^2} dz$ where the contour is any (simple) closed path that does not pass through $z = 0$.

Let us choose to integrate along this path from $z = z_0$ back to $z = z_0$, then we obtain

$$\oint_C \frac{1}{z^2} dz = \left[-\frac{1}{z} \right]_{z_0}^{z_0} = 0.$$

Note that this function is defined for all finite z that does not include $z = 0$.

As a follow-up to this, it is an instructive exercise to repeat the example, but now for a specific choice of contour e.g. a circle of radius a centred at the origin, so the path is $z = \gamma(\theta) = ae^{i\theta}$, $0 \leq \theta \leq 2\pi$:

$$\begin{aligned} \oint_C \frac{1}{z^2} dz &= \int_0^{2\pi} \frac{1}{(ae^{i\theta})^2} aie^{i\theta} d\theta = \frac{i}{a} \int_0^{2\pi} e^{-i\theta} d\theta \\ &= -\frac{1}{a} \left[e^{-i\theta} \right]_0^{2\pi} = -\frac{1}{a} (e^{-2\pi i} - 1) = 0. \end{aligned}$$

We now investigate an example with important consequences but which, at first sight, appears to be essentially a repeat of the previous one. The difficulties that we encounter are most easily seen by attempting the calculation for a specific contour, exactly as we have just done.

Example 22 *Contour integral III.* Find $\oint_C \frac{1}{z} dz$ where the contour is the circle $z = \gamma(t) = ae^{it}$, $0 \leq t \leq 2\pi$, i.e. the circle of radius a , centre at the origin, mapped out just once in the counter-clockwise direction.

Although there might be the temptation to use the integral of $1/z$ (i.e. $\log z$), this function is not well-defined (not being single-valued on one complete circuit around the origin); so we work from first principles. Thus we write

$$\oint_C \frac{1}{z} dz = \int_0^{2\pi} \frac{1}{ae^{it}} aie^{it} dt = \int_0^{2\pi} i dt = 2\pi i.$$

The answer in this case is not zero, even though the function $1/z$ is analytic on the chosen contour. That this has happened has far-reaching consequences. The important difference in this example becomes clear when we consider the log function (which should, presumably, be related to the integral of $1/z$, as we mentioned in the commentary in the solution). As we go once around the circle, but not crossing the branch cut, $\log z$ jumps in value by 2π (because the function is discontinuous across the branch cut):

$$\begin{aligned} [\log z]_{ae^{-i\pi}}^{ae^{i\pi}} &= [\log |z| + i(\Theta + 2n\pi)]_{ae^{-i\pi}}^{ae^{i\pi}} \quad (\text{for any } n) \\ &= \ln a + i(\pi + 2n\pi) - [\ln a + i(-\pi + 2n\pi)] = 2\pi i. \end{aligned}$$

The underlying reason for the result obtained in the previous example is now clear: the function that is the integral of $1/z$ is not continuous on the contour. This is in contrast to all our earlier work – underpinning the CR relations – which has dealt with continuous (and differentiable) functions.

Comment: It is usual to think of the jump in value as moving onto a parallel complex plane; these planes are called *Riemann sheets* (since he first thought of multiple values this way). This interpretation is depicted in the figures below; the first shows a 3D depiction, where the movement onto a new Riemann sheet is represented by spiralling up (or down); the second simply gives copies of the complex plane (in polars), repeated every 2π .

Need help with your dissertation?

Get in-depth feedback & advice from experts in your topic area. Find out what you can do to improve the quality of your dissertation!

Get Help Now



Go to www.helpmyassignment.co.uk for more info

 **Helpmyassignment**

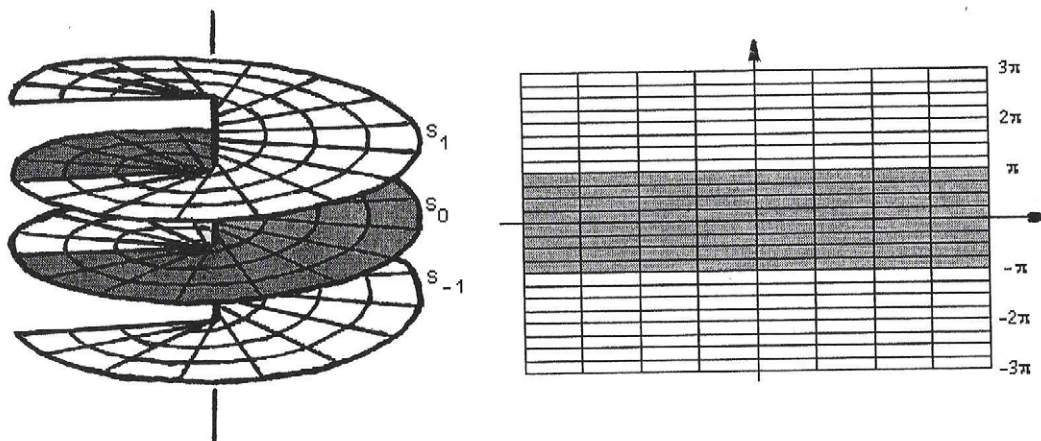

Riemann Sheets

Example 23 *Contour integral IV.* See Example 22; now let $0 \leq t \leq 2\pi n$, where n is an integer (positive or negative), so the circle is now mapped out n times.

As before, we write
$$\oint_C \frac{1}{z} dz = \int_0^{2n\pi} \frac{1}{ae^{it}} aie^{it} dt = \int_0^{2n\pi} i dt = 2\pi in.$$

The answer here – which should be compared with that obtained in the preceding example – shows that each rotation about the origin increases the value of the integral by $2\pi i$; n is then, quite naturally, called the *winding number*. An increase in n is equivalent to moving onto a different Riemann sheet.

Comment: If the given contour does not cross the branch cut (and so does not encircle the origin), then the problems associated with crossing the branch cut – as just described – cannot arise. To see this, consider the example of the contour $C: z = \gamma(\theta) = z_0 + ae^{i\theta}$, $0 \leq \theta \leq 2\pi$, with $|z_0| > a$. This circle, of radius a , with centre at $z = z_0$, is chosen so that the branch cut is not crossed:

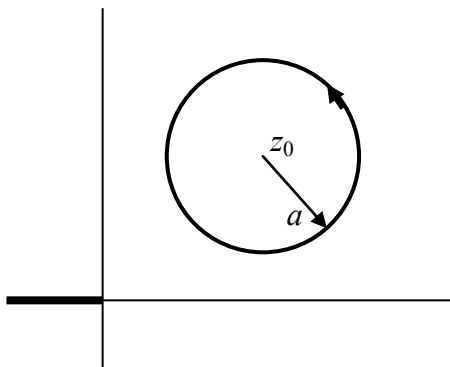

Thus we have

$$\oint_C \frac{dz}{z} = \int_0^{2\pi} \frac{aie^{i\theta}}{z_0 + ae^{i\theta}} d\theta = \left[\log(z_0 + ae^{i\theta}) \right]_0^{2\pi}$$

$$= \log(z_0 + ae^{2\pi i}) - \log(z_0 + a \cdot 1) = 0.$$

An important final calculation of this type, which we shall need later, arises when we consider the circular contour about the origin, but now integrate *any* power of z (power $\neq -1$); this we develop in the next example.

Brain power



By 2020, wind could provide one-tenth of our planet's electricity needs. Already today, SKF's innovative know-how is crucial to running a large proportion of the world's wind turbines.

Up to 25 % of the generating costs relate to maintenance. These can be reduced dramatically thanks to our systems for on-line condition monitoring and automatic lubrication. We help make it more economical to create cleaner, cheaper energy out of thin air.

By sharing our experience, expertise, and creativity, industries can boost performance beyond expectations. Therefore we need the best employees who can meet this challenge!

The Power of Knowledge Engineering

Plug into The Power of Knowledge Engineering.
Visit us at www.skf.com/knowledge



Click on the ad to read more

Example 24 Contour integral V. Find $\oint_C z^n dz$, $n \neq -1$, where C is $z = ae^{it}$, $0 \leq t \leq 2\pi$.

$$\begin{aligned} \text{We have } \oint_C z^n dz &= \int_0^{2\pi} (ae^{it})^n aie^{it} dt = ia^{1+n} \int_0^{2\pi} e^{i(1+n)t} dt \\ &= \frac{a^{1+n}}{1+n} \left[e^{i(1+n)t} \right]_0^{2\pi} = 0 \text{ for } n \neq -1. \end{aligned}$$

We see, therefore, that for all $n \neq -1$, with this contour around the origin, we obtain the zero value for the integral; only for the case $n = -1$ (the log integral) do we get a non-zero answer: $2\pi i$ (see Example 22).

Exercises 4

26. Evaluate these line integrals, along the given path $\gamma(t)$:

- (a) $\int_C z^3 dz$, $\gamma(t) = 2t$, $0 \leq t \leq 1$; (b) $\int_C z^3 dz$, $\gamma(t) = (1-t) + it$, $0 \leq t \leq 1$;
 © $\int_C \sin z dz$, $\gamma(t) = 3(1-t)$, $0 \leq t \leq 1$; (d) $\int_C \bar{z} dz$, $\gamma(t) = ae^{i\pi t}$, $0 \leq t \leq 1$;
 (e) $\int_C z^s e^z dz$, $\gamma(t) = te^{i\pi}$, $0 \leq t < \infty$ where s is a complex constant

(see Exercise 19).

27. Evaluate $\int_C (y - ix) dz$ along these paths, $z = z(t) = x(t) + iy(t)$:

- (a) $z = 2t - it$, $0 \leq t \leq 1$; (b) $z = 2t$, $0 \leq t \leq 1$, followed by $z = 2 - it$, $0 \leq t \leq 1$;
 © $z = -it$, $0 \leq t \leq 1$, followed by $z = 2t - i$, $0 \leq t \leq 1$; (d) $z = 2t - it^2$, $0 \leq t \leq 1$.

28. Repeat Exercise 27 (for all four paths) for the line integral $\int_C (y - ix) dz$.

29. Find the values of these integrals, where the end-points of the path are given in each case:

- (a) $\int_C z^2 dz$ from $z = 0$ to $z = i$; (b) $\int_C \sin(z) dz$ from $z = 0$ to $z = i\pi$;
 © $\int_C e^{-z} dz$ from $z = 1$ to $z = 1 - i$; (d) $\int_C z \sinh(z^2) dz$ from $z = -1$ to $z = i$.

30. Find the value of $\int_C \frac{dz}{z}$ along these paths, $z = \gamma(t) = x(t) + iy(t)$:

(a) $z = (1+i) - (2+i)t, 0 \leq t \leq 1$; (b) $z = -1 + (2-i)t, 0 \leq t \leq 1$; (c) $z = 1 + it, -1 \leq t \leq 1$.

Now sketch the path described by (a) + (b) + (c). Use your results to find the value of the integral around this (closed) path. [Remember to recast the path integrals into real integrals expressed in terms of the real parameter, t .]

What do you want to do?

No matter what you want out of your future career, an employer with a broad range of operations in a load of countries will always be the ticket. Working within the Volvo Group means more than 100,000 friends and colleagues in more than 185 countries all over the world. We offer graduates great career opportunities – check out the Career section at our web site www.volvogroup.com. We look forward to getting to know you!

VOLVO
 AB Volvo (publ)
www.volvogroup.com

VOLVO TRUCKS | RENAULT TRUCKS | MACK TRUCKS | VOLVO BUSES | VOLVO CONSTRUCTION EQUIPMENT | VOLVO PENTA | VOLVO AERO | VOLVO IT
 VOLVO FINANCIAL SERVICES | VOLVO 3P | VOLVO POWERTRAIN | VOLVO PARTS | VOLVO TECHNOLOGY | VOLVO LOGISTICS | BUSINESS AREA ASIA



5 The Integral Theorems

In the preceding chapters, we have introduced the important ideas of analytic functions – and so differentiability – and the meaning of, and methods for, integrating along contours (paths) in the complex plane. With this foundation in place, we now turn to the development, and proof, of some fundamental results that are both amazing and amazingly simple and elegant. These underpin the many applications of the theory of complex variables, some of which we will describe later.

5.1 Cauchy's Integral Theorem (1825)

We start with a description of the types of domain, in the complex plane, within which we shall be working; in particular, we introduce the concept of a *simply connected domain*. This is defined as follows:

A domain, D , is simply connected if *every* simple, closed curve (i.e. Jordan curve) within D encloses *only points of D* .

This situation is depicted in these figures:

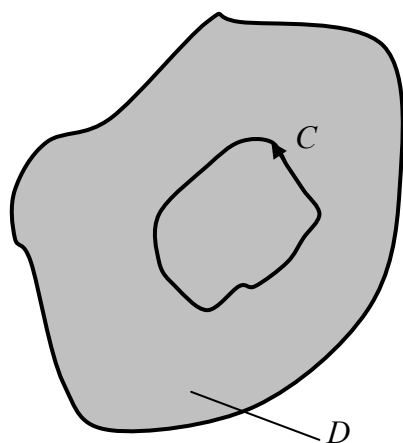

simply connected

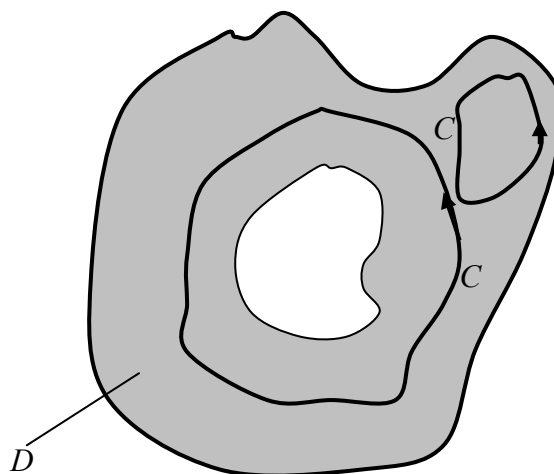

multiply connected

In the first figure, we see that the Jordan curve (labelled C), no matter how it is chosen, always contains points that are within D (the grey area). In the second figure, the domain – the grey area again – is defined between two bounding curves; in this case, some Jordan curves encircle only points of D , but any contour around ‘the hole’ does not. The first is *simply connected*, and the second is *multiply connected* (and with one ‘cut-out’, we usually say that it has a multiplicity of one).

To proceed, suppose that we are given $f(z)$ which is analytic throughout D , which is a simply-connected domain, and any Jordan curve (contour) C within D , mapped counter-clockwise (so that points interior to C are always to the left). Then we find that

$$\oint_C f(z) dz = 0,$$

which is our first fundamental result.

We present a proof of this theorem which is based on Green's theorem (with which the reader is assumed familiar):

Let us be given a Jordan curve, labelled Γ , which is mapped counter-clockwise; the region interior to Γ is labelled R . Further, we are given two functions, $u(x, y)$ and $v(x, y)$, which possess continuous first partial derivatives in R and on Γ . Although we can work separately with u or v , it is usual to combine the pair – particularly in the light of what we do here. The theorem is then expressed as

$$\oint_{\Gamma} [u(x, y) dx + v(x, y) dy] = \iint_R \left(\frac{\partial v}{\partial x} - \frac{\partial u}{\partial y} \right) dx dy.$$

In passing, we note that this identity can be interpreted as a two-dimensional version of Gauss' (divergence) theorem. This is obtained by taking, in Gauss' theorem, the divergence of the vector function $(v, -u)$ and, of course, restricting the geometry to the 2D plane (but remember that Green's theorem predates Gauss!).

Proof

Let C be represented by $z = \gamma(t)$, $t_0 \leq t \leq t_1$, with $\gamma(a) = \gamma(b)$, then

$$I = \oint_C f(z) dz = \int_a^b f[\gamma(t)] \gamma'(t) dt$$

and now write $f = u(x, y) + iv(x, y)$:

$$I = \int_a^b \{u[x(t), y(t)] + iv[x(t), y(t)]\} \gamma'(t) dt$$

on the curve. Further, let us write explicitly $\gamma(t) = x(t) + iy(t)$, then

$$I = \int_a^b \{u[x(t), y(t)] + iv[x(t), y(t)]\} [x'(t) + iy'(t)] dt.$$

Finally, this can be recast as line integrals in x and y :

$$I = \int_a^b \{u[x(t), y(t)] x'(t) - v[x(t), y(t)] y'(t)\} dt \\ + i \int_a^b \{u[x(t), y(t)] y'(t) + v[x(t), y(t)] x'(t)\} dt$$

$$= \int_C [u(x, y) dx - v(x, y) dy] + i \int_C [v(x, y) dx + u(x, y) dy].$$

This representation of the integral along a curve in the complex plane is the starting point for the integral theorems. Here, we have shown that

$$\oint_C f(z) dz = \oint_C [u(x, y) dx - v(x, y) dy] + i \oint_C [v(x, y) dx + u(x, y) dy].$$

The two real line integrals that we have now generated are rewritten using Green's theorem (all the conditions for which are satisfied, with R interior to C , which sits inside D):

$$\oint_C [u(x, y) dx - v(x, y) dy] = \iint_R \left(-\frac{\partial v}{\partial x} - \frac{\partial u}{\partial y} \right) dx dy$$

and
$$\oint_C [v(x, y) dx + u(x, y) dy] = \iint_R \left(\frac{\partial u}{\partial x} - \frac{\partial v}{\partial y} \right) dx dy.$$

But $f(z)$ is an analytic function, so the Cauchy-Riemann relations hold i.e. $u_x = v_y$ and $u_y = -v_x$ throughout D , and so also throughout R ; here we have used subscripts to denote partial derivatives. Thus the two double integrals above are zero, and hence



$$\oint_C f(z) dz = 0,$$

which is *Cauchy's Integral Theorem* (1825).

It is important to observe that this result – the integral around a Jordan curve in D – holds for any and every contour (Jordan curve) inside D .

Example 25 *Contour integral VI.* Given the contour $C: z = \gamma(t) = e^{it}$, $0 \leq t \leq 2\pi$, evaluate (if possible):
 (a) $\oint_C (z + e^z) dz$; (b) $\oint_C \frac{dz}{z - \frac{1}{2}}$.

(a) The given function, which is to be integrated around the contour, is $f(z) = z + e^z$, which is analytic inside and on C (indeed, it is an entire function), and so Cauchy's Integral Theorem gives directly the answer zero.

(b) In this case, the given function is $f(z) = 1/(z - \frac{1}{2})$ which is not analytic at $z = \frac{1}{2}$; this point sits inside the given contour (which is a circle of radius 1 centred at the origin). Thus the function is not analytic inside the contour, and so Cauchy's Integral Theorem is not applicable: we cannot evaluate this integral (at present).

Comment: In 1900, E. Goursat (1858-1936, a French mathematician), proved that

$$\oint_C f(z) dz = 0$$

provided only that $f(z)$ is analytic inside and on C ; there is no requirement for $f'(z)$ to be continuous – only that it exists. Some authors therefore refer to our theorem as the *Cauchy-Goursat theorem*.

We should also mention that there is a converse of Cauchy's integral theorem. If $f(z)$ is continuous throughout a domain, D , in the complex plane, and if $\oint_C f(z) dz = 0$ on every Jordan curve, C , that is within D , then $f(z)$ is analytic in D .

This is known as *Morera's theorem*; G. Morera (1856-1907), an Italian mathematician, proved this result in 1889.

5.2 Cauchy's Integral Formula (1831)

In Example 25 above, the second choice of function did not lead to an evaluation: the function to be integrated was not analytic inside the given contour because, at one point ($z = \frac{1}{2}$) the function was not defined.

We now extend the ideas, as developed by Cauchy, to accommodate this situation, and show that the value of such integrals can be found. (It is instructive to note that, in Example 25 (b), if a different contour had been chosen, so that the given function was analytic inside and on this new contour, then the value of the integral would be zero, by virtue of the Integral Theorem. Such a contour could be $|z + 1| = 1$: a circle of radius 1 with centre at $z = -1$; this does not enclose $z = \frac{1}{2}$.) The first stage in this extension of Cauchy's theorem (above) involves describing how Cauchy's Integral Theorem can be applied to a multiply-connected domain. Let us consider the following (bounded) domain:

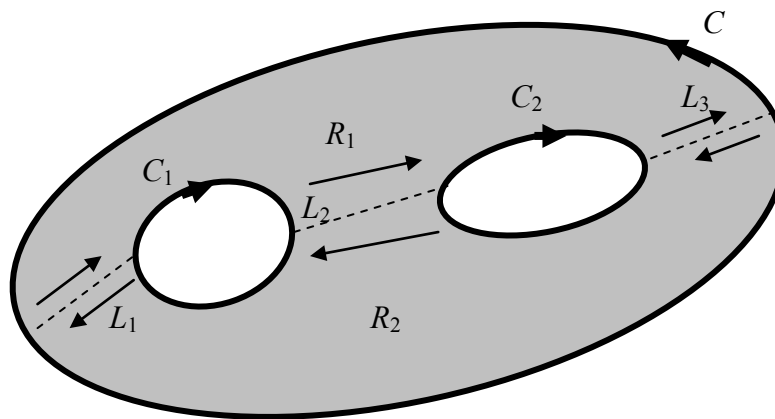

This figure represents a domain which contains two cut-outs – a multiplicity of two – defined by the contours C_1 and C_2 (each mapped *clockwise*, note) and inside the contour, C (mapped counter-clockwise), which defines the boundary of a domain in D . We introduce any appropriate lines (not necessarily straight), L_1, L_2, L_3 , that join C to C_1 , C_1 to C_2 , and C_2 to C again, respectively. The function $f(z)$ is analytic throughout the two regions so formed – labelled R_1 and R_2 – and on the boundaries of these two regions. The upshot of this is that $f(z)$ is analytic inside and on the boundaries of the two regions, R_1 and R_2 . Thus Cauchy's Integral Theorem applies to each:

$$\oint_{C'_1} f(z) dz = 0 \quad \text{and} \quad \oint_{C'_2} f(z) dz = 0,$$

where C'_1, C'_2 bound R_1, R_2 , respectively. For each of these contours, observe that points interior to the region, as the boundaries are mapped out, are always to the left (by virtue of our careful choice of mapping directions).

These two integrals, which clearly exist because of the analyticity of f and the bounded regions involved, are added; this results in the integrals along the line segments, L_1, L_2, L_3 , cancelling identically. (The integrals are equal and opposite, which we have indicated by the arrows in the figure.) Thus we have

$$\oint_{C'_1} f(z) dz + \oint_{C'_2} f(z) dz = \oint_{C+C_1+C_2} f(z) dz = 0,$$

and so

$$\oint_C f(z) dz = - \oint_{C_1+C_2} f(z) dz = \oint_{-(C_1+C_2)} f(z) dz,$$

because reversing the direction of the integration changes the sign of the integral. This new result, which has required no more than an application of Cauchy's Integral Theorem, describes the region shown in the figure below:

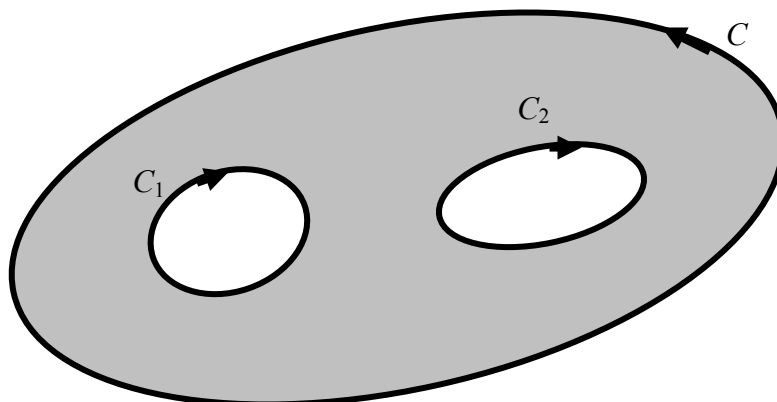

where the original directions have been retained. It is clear that this type of argument can be applied to a domain which comprises a bounding contour (C), and any (finite) number of holes/cut-outs. Let us take the special case of a multiplicity of one i.e. just a single cut-out:

This e-book
is made with
SetaPDF



SETASIGN

PDF components for PHP developers

www.setasign.com



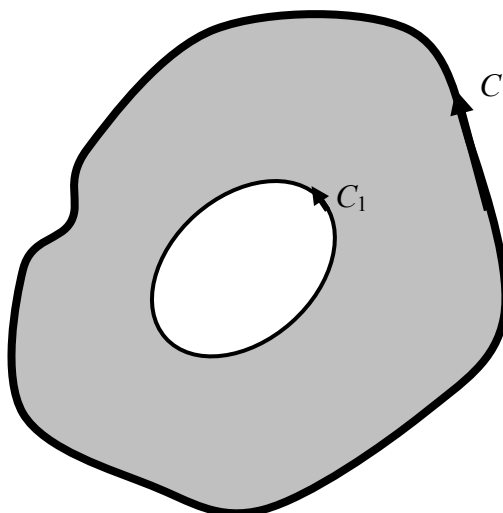

and note the reversed direction now chosen for mapping the contour defining the cut-out; here, $f(z)$ is analytic in the region between C and C_1 , and also on each of these contours. The result just obtained, applied in this case, then gives

$$\oint_C f(z) dz = \oint_{C_1} f(z) dz$$

(and note the sign change in this identity, brought about by the change of direction on C_1). Thus, given any contour C_1 , every contour outside this, like C , gives the same result i.e. every contour that is inside a given C , and which encircles C_1 , has the same value of contour integral. In consequence, the integral around the bounding contour (C), and *any* single interior contour, are equal.

This important deduction, based on the first theorem of Cauchy, provides the mechanism for deriving his second fundamental result. To do this, we consider the integral

$$\oint_C \frac{f(z)}{z - z_0} dz,$$

where $f(z)$ is analytic inside and on C , and where z_0 is an interior point; the proof follows.

Proof

The function $f(z)/(z - z_0)$ is clearly not analytic *everywhere* inside C , but it is *on* C (and on C the integral exists and is unique: it is simply a line integral). We use our new result by defining a multiply-connected region, so that the contour inside encircles the point z_0 . Further, the value of the integral that we require (around C) is equal to the value around any (and every) contour inside, so we may choose any one that is suitable. We elect to use a circle of radius r centred on z_0 and, because z_0 is strictly interior, we may always choose a radius that ensures that the whole circle remains inside C , no matter how small the radius might be. We now have the following configuration, where the specially chosen circular contour is C_0 :

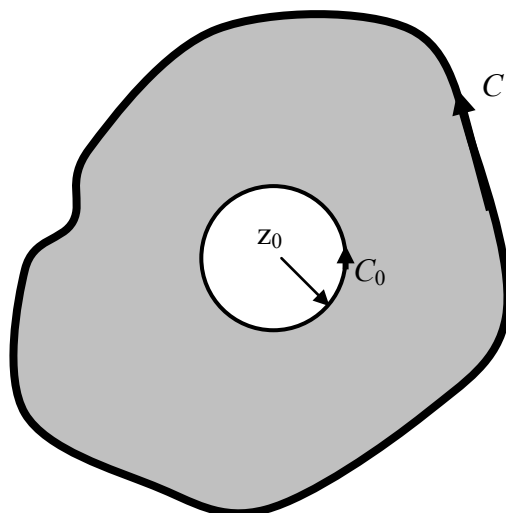

From the identity just derived, applied in this case, we obtain

$$\oint_C \frac{f(z)}{z-z_0} dz = \oint_{C_0} \frac{f(z)}{z-z_0} dz$$

and we write the contour, $C_0: z = z_0 + re^{i\theta}$, $0 \leq \theta \leq 2\pi$. Thus we have

$$\oint_C \frac{f(z)}{z-z_0} dz = \int_0^{2\pi} \frac{f(z_0 + re^{i\theta})}{re^{i\theta}} rie^{i\theta} d\theta = i \int_0^{2\pi} f(z_0 + re^{i\theta}) d\theta,$$

where we may take r to be as small as we wish: we may select a circle infinitesimally close to z_0 (because the radius of the circle, or the shape of any contour around z_0 , is irrelevant). Remember that $f(z)$ is analytic throughout the interior of C , so $f(z_0)$ certainly exists and is continuous. With this choice of r , i.e. $r \rightarrow 0$, we finally obtain

$$\oint_C \frac{f(z)}{z-z_0} dz = i \int_0^{2\pi} f(z_0) d\theta = if(z_0) \int_0^{2\pi} d\theta = 2\pi if(z_0)$$

that is

$$\oint_C \frac{f(z)}{z-z_0} dz = 2\pi if(z_0),$$

which is *Cauchy's Integral Formula* (1831).

Comment: An alternative way to analyse this technical problem is as follows. We have the integral

$$I(r) = i \int_0^{2\pi} f(z_0 + re^{i\theta}) d\theta,$$

for any given f and z_0 ; the derivative with respect to r then leads to

$$I'(r) = i \int_0^{2\pi} f'(z_0 + re^{i\theta}) e^{i\theta} d\theta = \left[\frac{1}{r} f(z_0 + re^{i\theta}) \right]_0^{2\pi},$$

where the resulting integral (which has been integrated directly) exists because f' is defined throughout the interior of C . Thus we see that, for all $r \neq 0$ (but this still allows $r \rightarrow 0$), we have

$$I'(r) = \left[\frac{1}{r} f(z_0 + re^{i\theta}) \right]_0^{2\pi} = 0;$$

thus the value of I is independent of r , and so any choice of r will give the value of I for all r . The choice we make is $r \rightarrow 0$.

Cauchy's Integral Formula is remarkable on two levels. First, a rather general problem in integration – and $f(z)$ is any analytic function – is reduced to a simple algebraic exercise. There is, however, something even more surprising; let us write the formula as

$$f(z) = \frac{1}{2\pi i} \oint_C \frac{f(z')}{z' - z} dz',$$

which follows after a relabelling. This demonstrates that, given a function on C only, then we can determine the function completely at every interior point. (Nothing close to this type of property exists in the theory of integration for real functions.)

Example 26 *Cauchy's Integral Formula.* Find the value of $\oint_C \frac{z + e^z}{z^2 - 1} dz$, where C , mapped counter-clockwise, are these circles:

- (a) $|z| = 1/2$; (b) $|z - 1| = 1/2$; (c) $|z + 1| = 1/2$.

www.sylvania.com

We do not reinvent the wheel we reinvent light.

Fascinating lighting offers an infinite spectrum of possibilities: Innovative technologies and new markets provide both opportunities and challenges. An environment in which your expertise is in high demand. Enjoy the supportive working atmosphere within our global group and benefit from international career paths. Implement sustainable ideas in close cooperation with other specialists and contribute to influencing our future. Come and join us in reinventing light every day.

OSRAM SYLVANIA

Light is OSRAM



The integrand here can be written as $f(z) = \frac{z + e^z}{(z+1)(z-1)}$, which is not analytic at $z = \pm 1$; these two points, and the three choices of circle, are shown in the figure.

(a) For this choice, the integrand is analytic inside and on C , and so Cauchy's Integral Theorem is valid:

$$\oint_C \frac{z + e^z}{z^2 - 1} dz = 0..$$

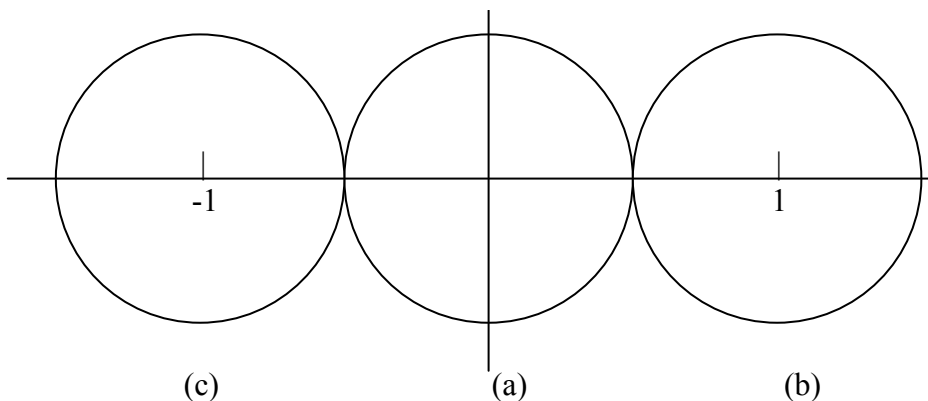

(b) The circle in this case encircles just the point $z = 1$, so we write the problem as $\oint_C \frac{(z + e^z)/(z+1)}{z-1} dz$ where this (new) numerator is analytic inside and on C ; thus we may apply Cauchy's Integral Formula to give

$$\oint_C \frac{(z + e^z)/(z+1)}{z-1} dz = 2\pi i \left(\frac{1 + e^1}{1+1} \right) = (1 + e)\pi i.$$

(c) We use the same type of approach as adopted in (b); we write the problem as $\oint_C \frac{(z + e^z)/(z-1)}{z+1} dz$, where the numerator here is analytic inside and on the contour C ; thus

$$\oint_C \frac{(z + e^z)/(z-1)}{z+1} dz = 2\pi i \left(\frac{-1 + e^{-1}}{-1-1} \right) = (1 - e^{-1})\pi i.$$

In this example, we have worked with some specific contours – various circles – but any contours that encircle the zeros of the denominator (or avoid them altogether), exactly as the circle do, will give the same values for the integral. This is described above, in the preamble to Cauchy's Integral Formula; thus, for the preceding example, we could use:

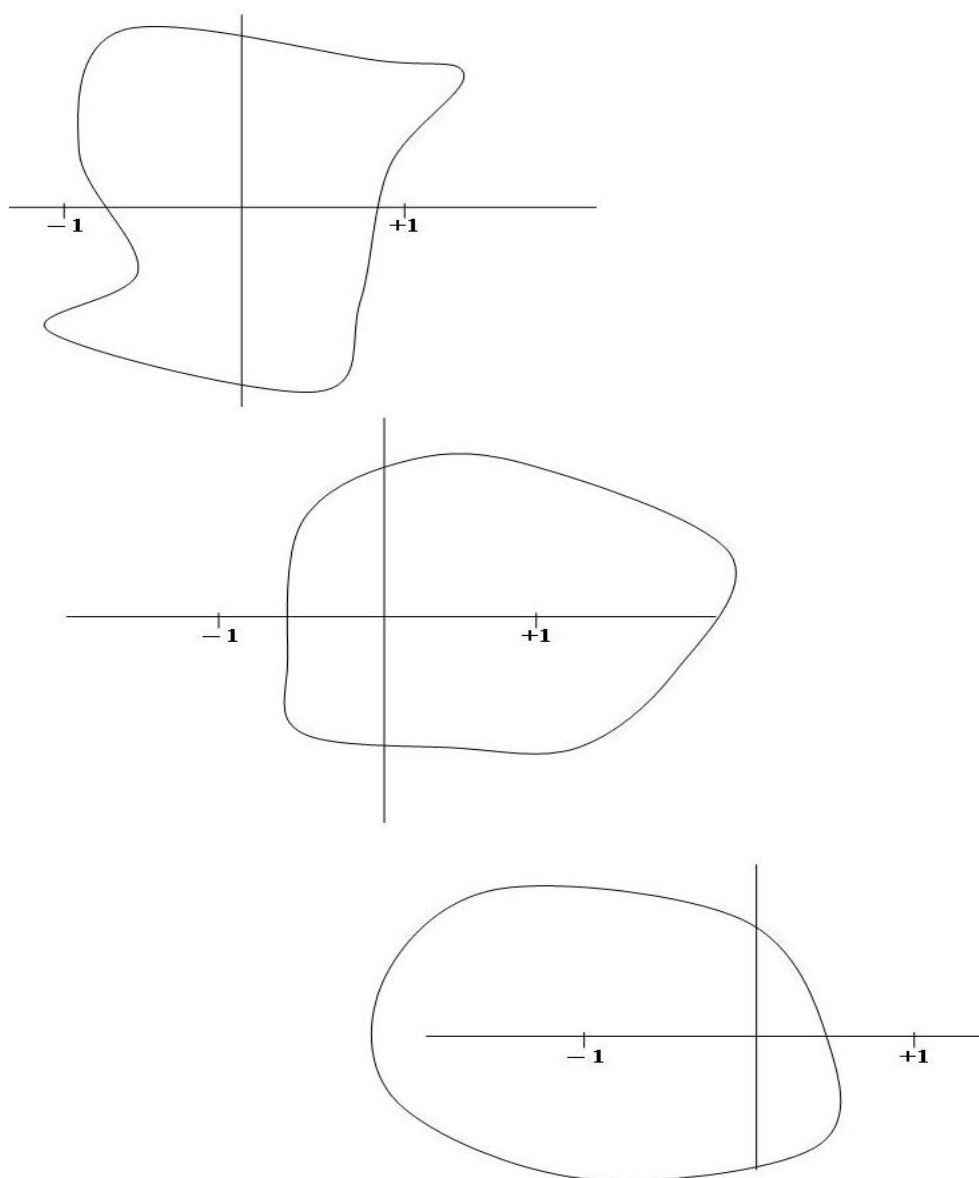

for exercises (a), (b) and (c), respectively, and obtain the same answers.

5.3 An integral inequality

A result that we shall need in order to complete the demonstration (and proof), involved in the evaluation of real integrals, requires an important and fundamental idea in the theory of integration. Indeed, we start with a standard result for real integrals, and then show how this can be extended to contour integrals in the complex plane.

For real integrals, we have the familiar result on a bounded domain:

$$\left| \int_a^b f(x) dx \right| \leq \int_a^b |f(x)| dx .$$

This is an elementary property of classical (real) integrals. It follows, either by considering what happens if the function to be integrated is somewhere negative-valued, and this is replaced by $|f(x)|$: clearly the integral (provided it exists) of $|f(x)|$ is greater than (or equal to) the integral of $f(x)$ (on the same interval). More formally, let us suppose that $-\infty < m \leq f(x) \leq M < \infty$, then

$$m(b-a) \leq \int_a^b f(x) \, dx \leq M(b-a),$$

which bounds the corresponding area, above and below, by suitable rectangles.

Indeed, if $m = 0$ (so $f \geq 0$), then $\int_a^b f(x) \, dx \geq 0$.

We use this idea in a slightly different form: for any $f(x)$, then $f(x) \leq |f(x)|$ (where equality holds if $f \geq 0$, and the inequality for $f < 0$). Thus we have

$$\int_a^b f(x) \, dx \leq \int_a^b |f(x)| \, dx \quad \text{and so} \quad \left| \int_a^b f(x) \, dx \right| \leq \int_a^b |f(x)| \, dx = \int_a^b |f(x)| \, dx,$$

which is the required result.

We need the version of this result that applies to contour integrals in the complex plane. In order to interpret this property, which applies to real functions as presented above, we write



Discover the truth at www.deloitte.ca/careers

Deloitte.

© Deloitte & Touche LLP and affiliated entities.



$$\int_C f(z) dz = \int_{t_0}^{t_1} f[\gamma(t)]\gamma'(t) dt,$$

on the path $C: z = \gamma(t), t_0 \leq t \leq t_1$. The result of this integration is to produce an answer that is – of course – a complex number; let this be written as $R e^{i\phi}$, and so

$$\int_C f(z) dz = \int_{t_0}^{t_1} f[\gamma(t)]\gamma'(t) dt = R e^{i\phi}.$$

This is rewritten in the form

$$e^{-i\phi} \int_C f(z) dz = e^{-i\phi} \int_{t_0}^{t_1} f[\gamma(t)]\gamma'(t) dt = R$$

which is real and positive because R is the modulus of the complex number which is the value of the integral. Now we take the modulus of this identity:

$$\left| e^{-i\phi} \int_C f(z) dz \right| = \left| \int_C f(z) dz \right| = R = e^{-i\phi} \int_{t_0}^{t_1} f[\gamma(t)]\gamma'(t) dt.$$

This last term then gives

$$e^{-i\phi} \int_{t_0}^{t_1} f[\gamma(t)]\gamma'(t) dt = \int_{t_0}^{t_1} e^{-i\phi} f[\gamma(t)]\gamma'(t) dt,$$

which, from above, is necessarily real i.e.

$$\int_{t_0}^{t_1} e^{-i\phi} f[\gamma(t)]\gamma'(t) dt = \int_{t_0}^{t_1} \Re \left\{ e^{-i\phi} f[\gamma(t)]\gamma'(t) \right\} dt + i \int_{t_0}^{t_1} \Im \left\{ e^{-i\phi} f[\gamma(t)]\gamma'(t) \right\} dt$$

where the second integral is zero. But

$$\Re \left\{ e^{-i\phi} f[\gamma(t)]\gamma'(t) \right\} \leq \left| e^{-i\phi} f[\gamma(t)]\gamma'(t) \right|$$

because, always,

$$a = \Re(a + ib) \leq |a + ib| = \sqrt{a^2 + b^2};$$

so

$$R = \int_{t_0}^{t_1} e^{-i\phi} f[\gamma(t)]\gamma'(t) dt = \int_{t_0}^{t_1} \Re \left\{ e^{-i\phi} f[\gamma(t)]\gamma'(t) \right\} dt \leq \int_{t_0}^{t_1} \left| e^{-i\phi} f[\gamma(t)]\gamma'(t) \right| dt.$$

Finally, we write

$$\int_{t_0}^{t_1} \left| e^{-i\phi} f[\gamma(t)]\gamma'(t) \right| dt = \int_{t_0}^{t_1} |f[\gamma(t)]\gamma'(t)| dt,$$

and so we obtain
$$\left| \int_C f(z) dz \right| \leq \int_{t_0}^{t_1} |f[\gamma(t)]\gamma'(t)| dt,$$

or, written in the more usual short-hand style,

$$\left| \int_C f(z) dz \right| \leq \int_C |f(z)| |dz|.$$

This result precisely mirrors the standard result for real functions – perhaps no surprise since it simply makes use of the modulus function. This integral inequality can be used exactly as written in this latter form, but it is sometimes useful to interpret it *via* the real parameter, t , as in the preceding expression.

5.4 An application to the evaluation of real integrals

We shall write quite a lot about how these ideas, appropriate for the complex plane, can be used to evaluate certain real integrals. For the moment, let us give a fairly simple introduction to the basic method and thinking, which should be both instructive and intriguing. The idea is fundamentally straightforward: for some given real integral, with an integration variable x , say, then replace this by z (so that on $y = 0$ we recover the original integration variable). Then we introduce a suitable contour (in the complex plane) and use an integral theorem to evaluate this; the extraction of the evaluation along the real axis – and therefore the desired result – is then almost immediate. We will develop and explain the details in the case of a familiar integral (which can be evaluated by employing routine methods, and this is therefore available as a comparison and a check).

We consider the problem $\int_0^{\infty} \frac{dx}{1+x^2}$; this is easily evaluated using conventional methods:

$$\int_0^{\infty} \frac{dx}{1+x^2} = [\arctan x]_0^{\infty} = \frac{1}{2}\pi.$$

So we already know the answer; can we now recover this using the technique outlined above?

We construct the associated problem $\oint_C \frac{dz}{1+z^2}$, where C is chosen to enclose a suitable semi-circular region:

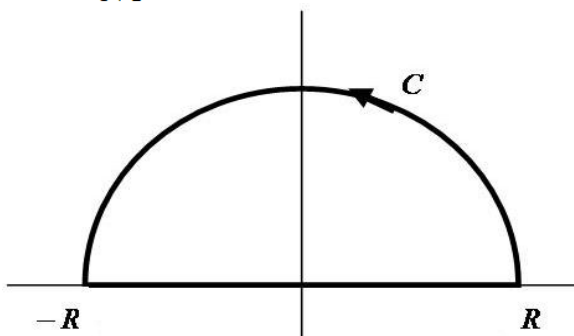

The contour integral, evaluated along the real axis, then becomes $\int_{-R}^R \frac{dx}{1+x^2}$, and so we shall need to take $R \rightarrow \infty$

(and then cope with the lower limit being 0 and not $-\infty$ later). Returning to the contour integral, we see that

$$\frac{1}{1+z^2} = \frac{1}{(z+i)(z-i)}$$

i.e. this function has zeros in the denominator at $z = \pm i$, and one of these might occur inside the semicircle that we have chosen. So that, as the radius increases, we do not move from a region without, and then a region with, $z = i$ inside, we choose the semicircle, at the outset, so that $R > 1$:

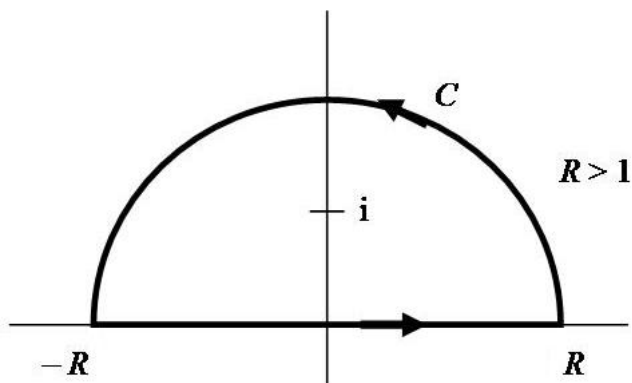

The integral can be evaluated, on this contour, by using Cauchy's Integral Formula:

$$\oint_C \frac{dz}{1+z^2} = \oint_C \frac{1/(z+i)}{z-i} dz = 2\pi i \frac{1}{i+i} = \pi.$$

SIMPLY CLEVER

ŠKODA



We will turn your CV into an opportunity of a lifetime

Do you like cars? Would you like to be a part of a successful brand? We will appreciate and reward both your enthusiasm and talent. Send us your CV. You will be surprised where it can take you.

Send us your CV on www.employerforlife.com

Click on the ad to read more

We see that the function $1/(z+i)$ is analytic on and inside the semi-circular contour chosen; certainly it is not analytic at the one point $z = -i$, but this is *outside* the contour.

Now we have

$$\oint_C \frac{dz}{1+z^2} = \int_{-R}^R \frac{dx}{1+x^2} + \int_{sc} \frac{dz}{1+z^2} \quad (= \pi) \tag{*}$$

where 'sc' denotes the integration along the semi-circular path; we need this integral or, rather, an *estimate* of the value of the integral on this path. We represent this path in the form $z = R e^{i\theta}$, $0 \leq \theta \leq \pi$, and use the integral inequality:

$$\left| \int_C \frac{dz}{1+z^2} \right| \leq \int_0^\pi \left| \frac{iR e^{i\theta}}{1+z^2} \right| d\theta,$$

and then the triangle inequality

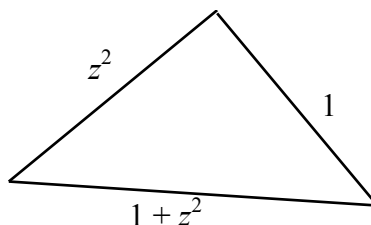

to give $|1+z^2| + 1 \geq |z^2| = R^2$ on the semicircle.

Thus $|1+z^2| \geq R^2 - 1$ and so $\frac{1}{|1+z^2|} \leq \frac{1}{R^2 - 1}$,

enabling the integral inequality to be written as

$$\left| \int_C \frac{dz}{1+z^2} \right| \leq R \int_0^\pi \frac{d\theta}{R^2 - 1} = \frac{R}{R^2 - 1} \int_0^\pi d\theta = \frac{\pi R}{R^2 - 1} \rightarrow 0 \text{ as } R \rightarrow \infty.$$

(Note that we have used the elementary property: $|ie^{i\theta}| = 1$.)

To complete the argument, we let $R \rightarrow \infty$ in the result (*) above; the first (real) integral approaches the one that we require (almost), and the second tends to zero (and the sum of the two integrals remains equal to π):

$$\int_{-\infty}^{\infty} \frac{dx}{1+x^2} = \pi.$$

This integrand, however, is even and so the integral on $[0, \infty)$ is half this value:

$$\int_0^\infty \frac{dx}{1+x^2} = \frac{1}{2} \pi,$$

as required. The expected result has been obtained without recourse to integration in any conventional sense. Indeed, the familiar philosophy: to evaluate a definite integral, first find the indefinite integral and then impose the limits, does not appear in any form here. The definite integral is found directly and by an essentially algebraic process only.

Example 27 *Real integral I.* Find $\int_{-\infty}^{\infty} \frac{\cos x}{1+x^2} dx$ (and we may assume that the integral along the appropriate semi-circular arc $\rightarrow 0$ as its radius $\rightarrow \infty$).

In order to evaluate this definite integral, we consider

$$\oint_C \frac{e^{iz}}{1+z^2} dz,$$

and this is the choice to make, rather than $\cos z/(1+z^2)$, as we will explain shortly. Then, on $z = x$, the real part gives us the desired integral.

We use exactly the same semi-circular contour above i.e. in the upper half-plane with $R > 1$ so that $z = i$ is inside; then we write

$$\oint_C \frac{e^{iz}/(z+i)}{z-i} dz = 2\pi i \left(\frac{e^{i \cdot i}}{i+i} \right) = \pi e^{-1}.$$

But

$$\oint_C \frac{e^{iz}}{1+z^2} dz = \int_{-R}^R \frac{e^{ix}}{1+x^2} dx + \int_{sc} \frac{e^{iz}}{1+z^2} dz \quad (= \pi e^{-1}),$$

and so, as $R \rightarrow \infty$, with the assumed result on the semicircle, we obtain

$$\int_{-\infty}^{\infty} \frac{\cos x + i \sin x}{1+x^2} dx = \pi e^{-1} \quad \text{i.e.} \quad \int_{-\infty}^{\infty} \frac{\cos x}{1+x^2} dx = \pi e^{-1}.$$

In this example, as an additional result to the one requested, we see that

$$\int_{-\infty}^{\infty} \frac{\sin x}{1+x^2} dx = 0$$

an otherwise obvious result (provided that $\int_0^{\infty} \frac{\sin x}{1+x^2} dx$ exists – and it does) because the integrand is an odd function.

Comment: The result that we are asked to assume is that $\int_{sc} \frac{e^{iz}}{1+z^2} dz \rightarrow 0$ as the radius of the semicircle tends to infinity. This is the case because

$$\left| \frac{e^{iz}}{1+z^2} \right| \leq \frac{|e^{iz}|}{R^2-1} = \frac{|e^{ix}| e^{-y}}{R^2-1} = \frac{e^{-y}}{R^2-1},$$

where the denominator is constructed exactly as in our earlier discussion; in the numerator $e^{-y} \leq 1$ on the semicircle in the upper-half plane. Thus the inequality arguments follow as before. This is an example of *Jordan's Lemma*: given $|f(z)| \leq K(R) \rightarrow 0$ as $R \rightarrow \infty$ on the semicircle, then

$$\left| \int_{sc} e^{ikz} f(z) dz \right| \rightarrow 0 \text{ as } R \rightarrow \infty \text{ for any real } k > 0.$$

The examples that we have discussed (above) contain terms such as $1/(1+z^2)$, which have just two points at which the function is not defined (and so is not analytic) – and only one such point sits inside the chosen contour. What happens to our integral theorem (the Cauchy Integral Formula) if there is more than one such point inside the contour? To answer this – and we must! – we first digress (Chapter 6) to introduce a generalisation of the familiar Taylor expansion (as encountered for real functions).

Exercises 5

31. Use Cauchy's Integral Theorem or Cauchy's Integral Formula (as appropriate) to evaluate $\oint_C f(z) dz$, where C is the unit circle $|z| = 1$, mapped counter-clockwise.

The function $f(z)$ is:

- (a) $3z^2 + z^3$; (b) $\frac{z^2}{z-3}$; (c) $\frac{z}{2z-1}$; (d) $\frac{e^z}{z}$; (e) $\frac{z-e^z}{z+2}$; (f) $\frac{1+z^2}{z^2+2z}$; (g) $\frac{ze^{z\pi}}{2z-i}$; (h) $\frac{z}{3z^2-10z+3}$;
 (i) $\frac{\cos z}{z(z^2+4)}$; (j) $\frac{1+z}{9+z^2}$; (k) $\frac{z}{9z^2-26z-3}$; (l) $\frac{e^z}{2z^2+3z-2}$; (m) $\frac{ie^{z\pi}}{2z^2+5iz-2}$.

32. Evaluate $\oint_C \frac{1+e^{z\pi/2}}{z^3+(i-2)z^2-2iz} dz$, where C , mapped counter-clockwise, is the circle:

- (a) $|z| = 1/2$; (b) $|z-1| = 1/2$; (c) $|z-2| = 1$; (d) $|z+i| = 1/2$; (e) $|z-i| = 1/2$.

33. In the following integrals, the contour, C , is the unit circle ($|z| = 1$), mapped counter-clockwise; a is a real constant. Suitably rewrite the integrands, and hence evaluate them by Cauchy's Integral Formula.

- (a) $\oint_C \frac{dz}{z(z-a)}$; (b) $\oint_C \frac{\bar{z}}{z-a} dz$.

Note: The integrals, on the given contour, are not defined for $|a| = 1$, but consider the other two possibilities: $|a| > 1$, $|a| < 1$.

6 Power Series

A power series (of complex numbers) converges if the partial sums have a limit:

i.e.
$$S_n = z_1 + z_2 + \dots + z_n \text{ and } \lim_{n \rightarrow \infty} (S_n) = S \text{ (finite),}$$

and then necessarily $z_n \rightarrow 0$. (You will be aware that this is, indeed, a necessary condition, but not a sufficient one; consider the familiar partial sum

$$S_n = 1 + \frac{1}{2} + \frac{1}{3} + \dots + \frac{1}{n}.)$$

All the power series that correspond to those encountered in any introductory study of real functions exist, and can be constructed. Thus we have, for example,

$$(1+z)^n = 1 + nz + \dots + z^n \text{ (the binomial expansion)}$$

$$(1+z)^{-1} = 1 - z + z^2 + \dots = \sum_{n=0}^{\infty} (-z)^n, \quad |z| < 1$$

(another binomial expansion)

I joined MITAS because
I wanted **real responsibility**

The Graduate Programme
for Engineers and Geoscientists
www.discovermitas.com



Real work
International opportunities
Three work placements



Month 16
I was a construction
supervisor in
the North Sea
advising and
helping foremen
solve problems



$$f(z) = \sum_{n=0}^{\infty} \frac{1}{n!} f^{(n)}(z_0)(z - z_0)^n \quad (\text{Taylor expansion}),$$

although, of course, there is no suggestion that all are valid for all z . The validity can be readily constructed; we will need, in detail, only the convergence condition for the binomial expansion, which can be based on the following discussion.

Example 28 *Power series.* Show that $\sum_{n=0}^{\infty} z^n$ converges to $1/(1 - z)$ for $|z| < 1$.

The method of proof follows the familiar approach taken from the study of the corresponding real series; we consider

$$S = 1 + z + \dots + z^n,$$

and then form $zS_n = z + z^2 + \dots + z^{n+1}$.

Subtracting these two gives $S_n - zS_n = 1 - z^{n+1}$ and so $S_n = \frac{1 - z^{n+1}}{1 - z}$; we now let $n \rightarrow \infty$, which produces a finite result for S_n only if $|z| < 1$ (exactly as for the real case). The sum is then $1/(1 - z)$, as required.

Note that, for this expansion, we have demonstrated that we require $|z| < 1$ for convergence i.e. for the power series to exist (have a meaning); the series is not defined for $z = 1$ and it oscillates (so not unique) for $z = -1$. This problem can be analysed in more detail by writing $z = re^{i\theta}$, $-\pi \leq \theta \leq \pi$, and consider $0 \leq r < 1$ for all θ . Thus we have

$$S_n = \frac{1 - r^{n+1} e^{i(n+1)\theta}}{1 - re^{i\theta}}$$

and then $n \rightarrow \infty$ requires, for convergence, $r < 1$; so $S_n \rightarrow S = \frac{1}{1 - re^{i\theta}} = \frac{1}{1 - z}$ for $|z| < 1$. We cannot allow $|z| > 1$ (i.e. $r > 1$), but we must examine the case $r = 1$.

Then we have $S_n = \frac{1 - (\cos n\theta + i \sin n\theta)}{1 - (\cos \theta + i \sin \theta)}$, where the terms in $n\theta$ oscillate as n increases, for any given $\theta \neq 0$: no limit exists. This leaves $\theta = 0$ ($z = 1$), for which the limit again does not exist, but now because the value of S_n is undefined (infinite). Thus we require $|z| < 1$ for convergence; the corresponding conditions for other familiar power series follow in the same manner, although the binomial series is the only one that we need to use in any detail in this introduction.

Let us return to the previous example:

$$(1 - z)^{-1} = \sum_{n=0}^{\infty} z^n \quad \text{for } |z| < 1;$$

we have shown that this fails – it is not defined – for $|z| = 1$, but is there any way that we can find an expansion valid for $|z| > 1$? At first sight, this might appear to be altogether impossible, but it can be done (and the resulting form is important for what we do shortly). Consider the following alternative version of the original function

$$\begin{aligned} \frac{1}{1-z} &= \frac{1}{z\left(\frac{1}{z}-1\right)} = -\frac{1}{z}\left(1-\frac{1}{z}\right)^{-1} \\ &= -\frac{1}{z}\left(1+\frac{1}{z}+\frac{1}{z^2}+\dots\right) = -\frac{1}{z}\sum_{n=0}^{\infty} z^{-n}, \end{aligned}$$

where the preceding result has been used, but now with validity $\left|\frac{1}{z}\right| < 1$ i.e. $|z| > 1$. So it is possible to construct a different expansion – no longer the familiar positive, integer powers – valid for $|z| > 1$. The development of a power series in inverse powers plays an important rôle in complex analysis; in fact, we find that we shall use *all* (integer) powers: both positive and negative.

6.1 The Laurent expansion (1843)

The *Laurent expansion*, about $z = z_0$, is written as

$$f(z) = \sum_{n=-\infty}^{\infty} c_n(z-z_0)^n,$$

where the c_n are complex constants; note that, previously, our simple expansions were about $z = 0$. This expansion allows for all positive and negative (integer) powers, but it is usually written down so as, explicitly, to separate these two sets:

$$f(z) = \sum_{n=0}^{\infty} a_n(z-z_0)^n + \sum_{n=1}^{\infty} \frac{b_n}{(z-z_0)^n}.$$

Such an expansion is necessarily associated with a function that has a *singularity* – it is undefined at $z = z_0$ – which then gives rise to the terms with a negative power. As we should expect, this will be valid, in general, only for certain z ; typically, this condition on validity takes the form $r_2 < |z-z_0| < r_1$, which is an annular region between two circles:

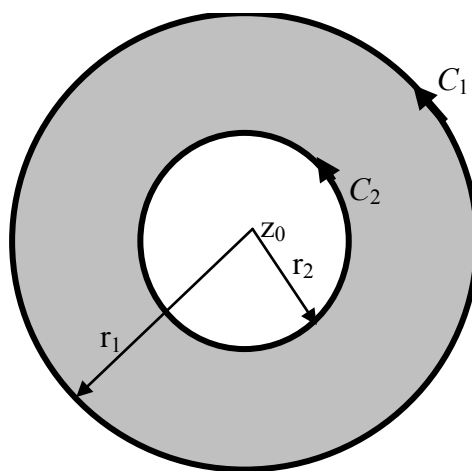

Note: We may treat this construction altogether formally and rigorously. So, given $f(z)$, we may determine (in a general framework cf. Taylor expansions) the coefficients a_n, b_n , and analyse the validity of the series. We will not pursue this line here because we will construct, from first principles, all the expansions (of specific simple functions) that we need; the appropriate validity then follows directly, as we shall see.

Here is an important observation. Let us suppose that we require $\oint_C f(z) dz$, and that $f(z)$ is represented by a Laurent expansion. Further, we suppose that the contour sits within the annular region and encircles $z = z_0$. (If the contour is not in the annular region, then we cannot proceed: the expansion is not valid, so it cannot be used.) We also know, from our earlier work, that any contour, satisfying the same positioning requirements, is allowed. Thus, we elect to use a circle, C_0 , of radius r , such that $r_2 < r < r_1$:

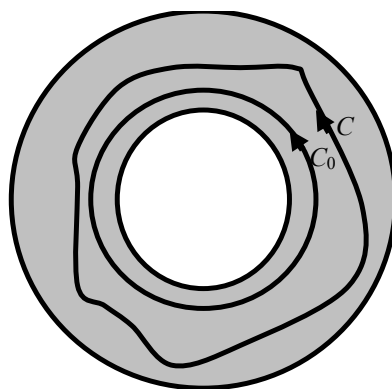

#1 EUROPEAN BUSINESS SCHOOL
FINANCIAL TIMES 2013

#gobeyond

MASTER IN MANAGEMENT

Because achieving your dreams is your greatest challenge. IE Business School's Master in Management taught in English, Spanish or bilingually, trains young high performance professionals at the beginning of their career through an innovative and stimulating program that will help them reach their full potential.

- Choose your area of specialization.
- Customize your master through the different options offered.
- Global Immersion Weeks in locations such as London, Silicon Valley or Shanghai.

Because you change, we change with you.

www.ie.edu/master-management

mim.admissions@ie.edu



the contour is therefore $C_0 : z = z_0 + re^{i\theta}$. Thus in our first notation for the Laurent expansion, we see that each term in the integral $\oint_C f(z) dz$, takes the form

$$c_n \int_0^{2\pi} \left(re^{i\theta} \right)^n rie^{i\theta} d\theta = \begin{cases} 0, & n \neq -1 \\ 2\pi ic_{-1}, & n = -1 \end{cases}$$

which follows directly from our Examples 22, 24. (We have assumed here that the integration and summation operations can be interchanged; this is a familiar property, provided that the original series, and the series obtained by integrating term-by-term, have a common region of convergence.) In our alternative notation, this reads

$$\oint_C f(z) dz = \oint_{C_0} f(z) dz = 2\pi ib_1.$$

Because the only term left behind after we have integrated, i.e. the only term required in the evaluation is b_1 , we call this the *residue* of $f(z)$ at $z = z_0$. Here we list a few other bits of terminology that we use in this context, or some relevant observations.

(a) If $f(z)$ is analytic throughout the interior of C_1 (see the figure at the beginning of this section), then $b_n = 0$ for all n (because the presence of any of these terms implies that the function is not defined at $z = z_0$).

(b) If $b_n = 0$ for $n \geq N + 1$, we have a *pole of order N* at $z = z_0$.

(c) If the b_n s extend to infinity, then we have an *isolated essential singularity* at $z = z_0$.

(d) Remember that we may choose any contour between C_1 and C_2 (encircling C_2) – they all give the same result for the contour integral.

Comment: So a function that has a Laurent series that terminates in the b_n s, for every singularity, has only *poles* (of a given order) and such a function is usually called a *meromorphic* function. That is, a meromorphic function has no essential singularities, but it does have poles; cf. analytic, which implies no singularities of any sort. [‘Meromorphic’ comes from Greek (μερος and μορφος), and means, literally, ‘part of the form/appearance’, which is to be compared with ‘holomorphic’ – which is sometimes used in place of ‘analytic’ as mentioned earlier – meaning, roughly, ‘whole of the appearance’.]

Example 29 *Laurent expansion I.* Write down the Laurent expansion of $e^{1/z}$ about $z = 0$.

We base this on the familiar Maclaurin expansion

$$e^{1/z} = 1 + \frac{1}{z} + \frac{1}{2!} \frac{1}{z^2} + \dots \text{ which is valid for all finite } 1/|z|;$$

this function therefore has an isolated essential singularity at $z = 0$.

In the previous example, we note that we have an isolated essential singularity at $z = 0$. In the next example, we see how our standard (binomial) expansions can produce a Laurent expansion; we also note that the simplest method for generating these expansions is by first writing the function in terms of partial fractions. (It can be shown, along the lines described earlier, that

$$(1+z)^\alpha = 1 + \alpha z + \frac{\alpha(\alpha-1)}{2!} z^2 + \frac{\alpha(\alpha-1)(\alpha-2)}{3!} z^3 + \dots$$

for any α , provided that $|z| < 1$. (If α is a positive integer, then this becomes the familiar identity – expansion – valid for all z .)

Example 30 *Laurent expansion II.* Find a Laurent expansion of $z/(z^2 + z - 2)$, about $z = 0$, which is valid for $z = 3/2$.

First we write $\frac{z}{z^2 + z - 2} = \frac{z}{(z+2)(z-1)} = \frac{1}{3} \left(\frac{1}{z-1} + \frac{2}{z+2} \right)$,

and then note the required validity, interpreted as $|z| > 1$ in the first term and $|z| < 2$ in the second. Thus, for the first term,

$$\frac{1}{z-1} = \frac{1}{z} \left(1 - \frac{1}{z} \right)^{-1} = \frac{1}{z} \sum_{n=0}^{\infty} \left(\frac{1}{z} \right)^n$$

which is valid for $\left| \frac{1}{z} \right| < 1$ i.e. $|z| > 1$; for the second we write

$$\frac{1}{z+2} = \frac{1}{2} \left(1 + \frac{z}{2} \right)^{-1} = \frac{1}{2} \sum_{n=0}^{\infty} \left(-\frac{z}{2} \right)^n,$$

which is valid for $\left| \frac{z}{2} \right| < 1$ i.e. $|z| < 2$. Thus we have

$$\frac{z}{z^2 + z - 2} = \frac{1}{3} \sum_{n=0}^{\infty} \left(-\frac{z}{2} \right)^n + \frac{1}{3} \sum_{n=1}^{\infty} \frac{1}{z^n},$$

which is valid in the annulus $2 > |z| > 1$.

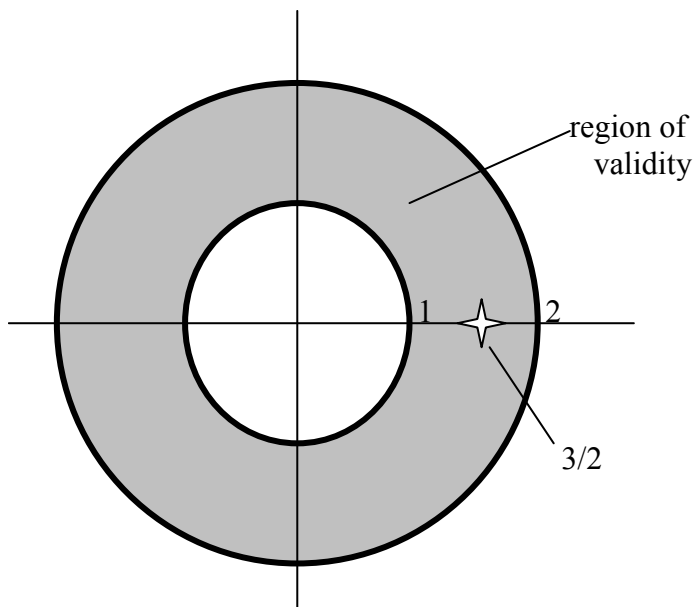

In this example, it should be noted that we have not expanded about the poles of the function (which are at $z = 1, -2$). Indeed, as $z \rightarrow 1$, the original function becomes $f(z) \approx (1/3)/(z-1)$ and as $z \rightarrow -2$ it becomes $f(z) \approx (2/3)/(z+2)$. Thus this function possesses two *simple poles* (i.e. *poles of order 1*), and so we can ‘read off’ the residues at these two poles directly:

no.1
nine years
in a row

Syeden
Stockholm

STUDY AT A TOP RANKED INTERNATIONAL BUSINESS SCHOOL

Reach your full potential at the Stockholm School of Economics, in one of the most innovative cities in the world. The School is ranked by the Financial Times as the number one business school in the Nordic and Baltic countries.

Visit us at www.hhs.se



residue at $z = 1$ is $\frac{1}{3}$; residue at $z = -2$ is $\frac{2}{3}$.

This property, and associate technique, are very useful, and make much of what we do later amazingly simple.

Note: A function such as $f(z) = \frac{z+2}{(z-1)(z^2-1)} = \frac{z+2}{(z-1)^2(z+1)}$ has a simple pole at $z = -1$ and a pole of order 2 at $z = 1$.

We now see how to find the Laurent expansions of a function like this, and also determine the residues at the poles.

Example 31 *Laurent expansion III.* Find Laurent expansions about the poles of $f(z) = (5z - 2i) / [z^2(z - 1)]$, and identify the residues.

We have poles at $z = 0$ (double) and at $z = 1$ (simple); we expand about $z = 0$ and about $z = 1$.

About $z = 0$:

$$f(z) = -\frac{1}{z^2}(5z - 2i)(1 - z)^{-1} = -\frac{1}{z^2}(5z - 2i)(1 + z + z^2 + \dots)$$

$$= -\frac{1}{z^2}(-2i + 5z - 2iz + \dots) = -\frac{1}{z^2}[-2i + (5 - 2i)z + \dots]$$

and so the residue at $z = 0$ (i.e. the coefficient of the term z^{-1}) is $2i - 5$.

About $z = 1$: it is easiest first to introduce $\zeta = z - 1$, to give

$$f = \frac{5(1 + \zeta) - 2i}{\zeta(1 + \zeta)^2} = \frac{1}{\zeta}(5 - 2i + 5\zeta)(1 - 2\zeta + 3\zeta^2 + \dots)$$

$$= \frac{1}{\zeta}[(5 - 2i) + \dots] = \frac{1}{z - 1}(5 - 2i + \dots)$$

and so the residue at $z = 1$ (i.e. the coefficient of the term $(z - 1)^{-1}$) is $5 - 2i$.

We observe that this second result – the residue at $z = 1$ – can be ‘read off’ directly from the original function, without recourse to any expansion.

Exercises 6

34. Obtain the Laurent expansions of these functions, about the point given and valid as prescribed in each case:

- (a) $\frac{1 + 2z}{z^3 + z^2}$ for $0 < |z| < 1$ (about $z = 0$); (b) $\frac{1}{4z - z^2}$ for $0 < |z| < 4$ (about $z = 0$);
- (c) $\frac{z}{z^2 - 4z + 3}$ for $0 < |z - 1| < 2$ (about $z = 1$);

- (d) $\frac{1}{3z - z^2 - 2}$ first for $0 \leq |z| < 1$ and then for $1 < |z| < 2$ (about $z = 0$ in each case);
- (e) $\frac{1+z}{z^2 + (2-i)z - 2i}$ for $1 < |z| < 2$ (about $z = 0$);
- (f) $\frac{5z+7}{z^2 + 3z+2}$ for $2 < |z-1| < 3$ (about $z = 1$).

35. Identify the poles (singular points) of these functions, and then find the corresponding residues:

- (a) $\frac{1}{z}$; (b) $\frac{2z}{1-z}$; (c) $\frac{e^z}{z-1}$; (d) $\frac{1}{z^2+z}$; (e) $\frac{e^{z\pi}}{1+z^2}$; (f) $\frac{1+z}{z^2-2z}$; (g) $\frac{1+e^z}{z^3}$;
- (h) $\frac{z^3}{(z+2)^2}$; (i) $\frac{1+z}{(z-i)z^2}$; (j) $\frac{1}{e^z-1}$.



#1
in eco-friendly attitude

STUDY AT LINKÖPING UNIVERSITY, SWEDEN
RANKED AMONG TOP 50 UNIVERSITIES UNDER 50

Interested in Strategy and Management in International Organisations? Kick-start your career with a master's degree from Linköping University, Sweden.

→ **Click here!**

 **Linköping University**



7 The Residue Theorem

The final, and most general, theorem enables the evaluation of a contour integral inside which there is more than one pole (singular point). We assume throughout this discussion that we can always, in the neighbourhood of each pole, construct a suitable Laurent expansion, the radius of validity then being away from the point, but not as far as the position of the next (nearest) pole.

7.1 The (Cauchy) Residue Theorem (1846)

We suppose that $f(z)$ is analytic inside and on the contour C , except at a finite number of points inside C , where we have singularities (poles), at z_1, z_2, \dots, z_n , say:

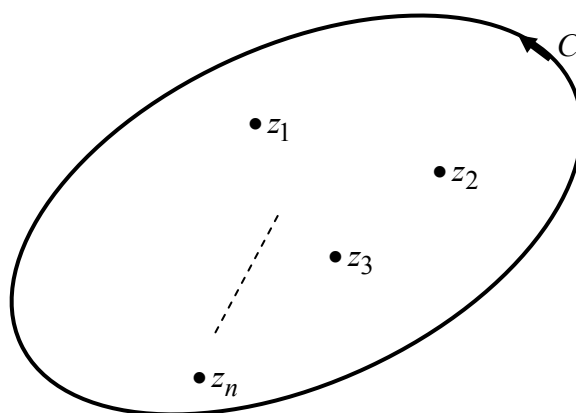

To proceed, we use the method of proof that we developed for Cauchy's Integral Formula. For the 'first' singularity – it could be any of them – we isolate it and add the familiar construction:

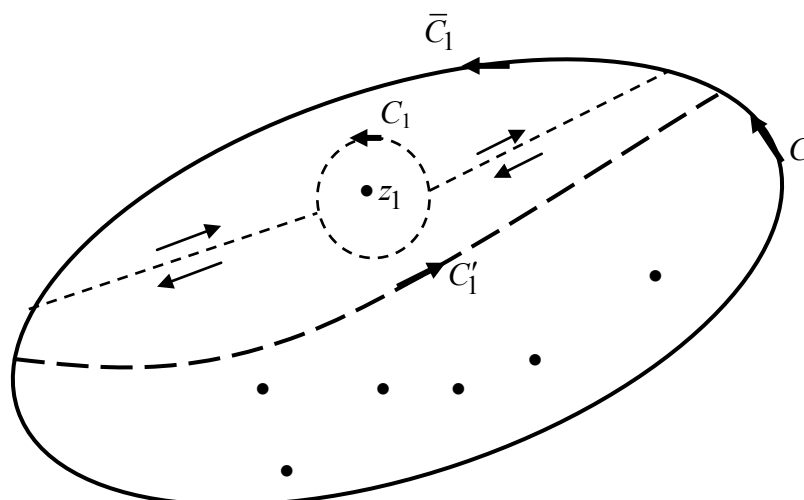

We consider the integral around the contour $C'_1 + \bar{C}_1$, which is a path within the domain (C'_1) enclosed by C , but isolating the first singularity, and completed by a part of C (\bar{C}_1). Inside this contour, we construct a closed contour around the singularity (C_1), together with the lines – not necessarily straight – that join the C_1 to $C'_1 - \bar{C}_1$. The argument used for Cauchy's Integral Formula (going around the two sub-domains so constructed, and the two results added) then gives

$$\int_{C'_1} f(z) dz + \int_{\bar{C}_1} f(z) dz - \oint_{C_1} f(z) dz = 0,$$

and note the direction/sign associated with the third term here. We now move to the 'second' singularity, constructing a second new contour that, in part, uses C'_1 but mapped in the *opposite* direction:

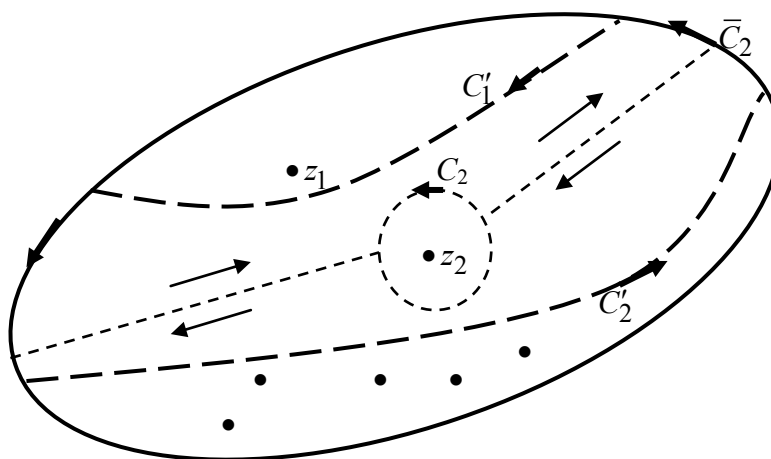

The new contour around which we integrate is now $C'_1 + \bar{C}_2 + C'_2$, where C'_1, C'_2 are the contours drawn inside C , and \bar{C}_2 is the next part of C . A repeat of the argument just invoked produces

$$-\int_{C'_1} f(z) dz + \int_{C'_2} f(z) dz + \int_{\bar{C}_2} f(z) dz - \oint_{C_2} f(z) dz = 0,$$

where the integral along C'_1 is exactly as before, but in the opposite direction; again, note the direction along C_2 . The two results just obtained are now added:

$$\int_{C'_2} f(z) dz + \int_{\bar{C}_1 + \bar{C}_2} f(z) dz - \oint_{C_1} f(z) dz - \oint_{C_2} f(z) dz = 0.$$

This process is continued across the domain inside C , picking up one singularity at a time. Eventually, the integrals along the boundaries of the new domains within C cancel (as happens above with C'_1 and $-C'_1$), leaving only the totality of C (constructed from the segments $\bar{C}_1 + \bar{C}_2 + \dots$) and the sum of each integral around each singularity:

$$\oint_C f(z) dz = \sum_{k=1}^n \left(\oint_{C_k} f(z) dz \right).$$

Thus, schematically, we have

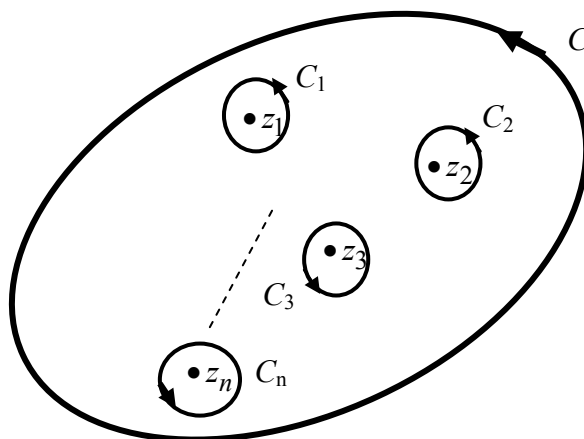

and we already know how to find the contribution from each pole: it is the residue of the function at the pole. Let the residue be B_k at the k th pole, then we have

$$\oint_C f(z) dz = 2\pi i \sum_{k=1}^n B_k :$$

the value of the integral along the contour C

$$= 2\pi i \times (\text{sum of the residues at the poles inside } C).$$

“I studied English for 16 years but...
...I finally learned to speak it in just six lessons”

Jane, Chinese architect

ENGLISH OUT THERE

Click to hear me talking before and after my unique course download



This is the *Residue Theorem*, sometimes called *Cauchy's Residue Theorem* – it is certainly his! – proved in 1846.

Example 32 *Residue Theorem.* Find $\oint_C \frac{e^z}{z^2(z^2+1)} dz$ where C , mapped counter-clockwise, is the circle $|z - \frac{1}{2}i| = 1$.

The integrand here has poles at $z = 0$ (double), at $z = i$ (simple) and at $z = -i$ (simple); the given contour – a circle – encloses the poles at $z = 0$ and $z = i$, but excludes the third (as shown in the figure). Thus we need to find the residues at $z = 0$ and $z = i$.

At $z = 0$: we write $\frac{e^z}{z^2(1+z^2)} = \frac{1}{z^2}(1+z+\dots)(1-z^2+\dots) = \frac{1}{z^2}(1+z+\dots)$

and so the residue is 1.

At $z = i$: we write $\frac{e^z}{z^2(1+z^2)} = \frac{e^z}{z^2(z+i)(z-i)} = \frac{1}{z-i} \left(\frac{e^i}{i^2(i+i)} + \dots \right)$,

which can be regarded as the beginning of an expansion near $z = i$, or obtained by invoking Cauchy's Integral Formula; the residue is therefore $-e^i/2i = \frac{1}{2}ie^i$.

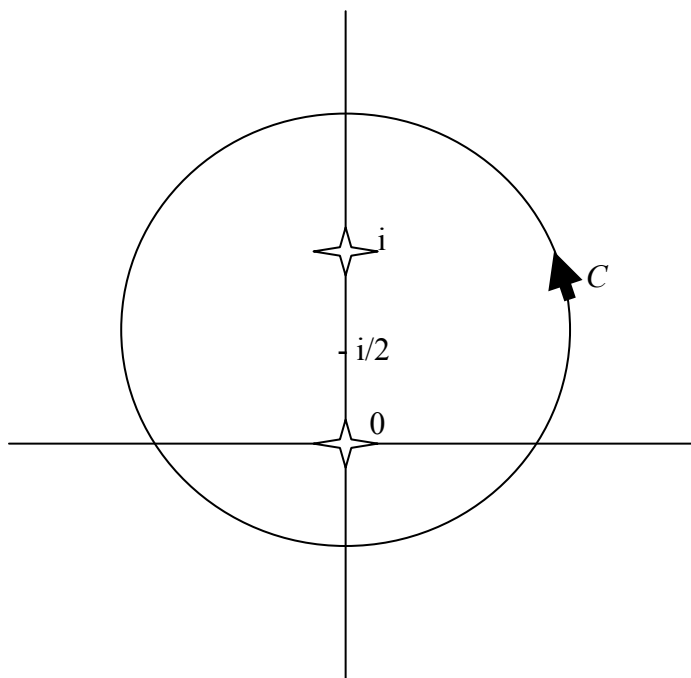

Thus

$$\oint_C \frac{e^z}{z^2(z^2+1)} dz = 2\pi i \left(\frac{1}{2}ie^i + 1 \right) = 2\pi \left(i - \frac{1}{2}e^i \right).$$

(We could write, if it is convenient to express the answer in a more usual format, $e^i = \cos 1 + i \sin 1$, and so obtain the real-imaginary form.)

Remember, on the basis of all our earlier comments and development, we would get the same answer for *any* contour that encloses the same pair of poles.

Comment: It is clear that the residue theorem subsumes both Cauchy’s integral theorem and integral formula. For, on the one hand, if the function is analytic – so no singular points anywhere – then all the b_n s will be zero for the Laurent expansions about every point; hence the value of the contour integral will be zero: Cauchy’s integral theorem. On the other hand, if the function to be integrated takes the form $f(z) = g(z)/(z - z_0)$, where $g(z)$ is analytic inside and on the contour and $z = z_0$ is an interior point, then there is a one singular point inside C with a residue $g(z_0)$, which recovers Cauchy’s integral formula.

7.2 Application to real integrals

We have already seen how this idea is used; see §5.4. We now extend this a little further by making full use of the Residue Theorem, that is, we consider a real integral that contains more than one pole inside the contour (when the problem is recast in the complex plane).

Example 33 *Real integral II.* Find the value of $\int_{-\infty}^{\infty} \frac{dx}{(x^2 + 2)^2 - 4x^2}$. (You may assume that the integral along a suitable semi-circular arc tends to zero as its radius increases.)

We consider the integral $\oint_C \frac{dz}{(z^2 + 2)^2 - 4z^2}$, where the denominator of the integrand can be written as

$$\begin{aligned} (z^2 + 2 - 2z)(z^2 + 2 + 2z) &= [(z - 1)^2 + 1][(z + 1)^2 + 1] \\ &= (z - 1 + i)(z - 1 - i)(z + 1 + i)(z + 1 - i) \end{aligned}$$

and the second and fourth factors here correspond to simple poles in the upper half-plane. Thus we choose the contour shown in the figure

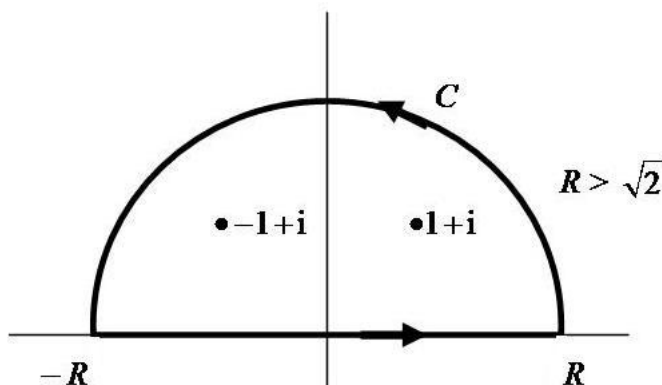

The residue at $z = 1 + i$ is obtained by writing

$$\frac{1}{(z^2 + 2)^2 - 4z^2} = \frac{1}{z - 1 - i} \left[\frac{1}{(1 + i - 1 + i)(1 + i + 1 + i)(1 + i + 1 - i)} + \dots \right]$$

which gives

$$\frac{1}{2i \cdot 2(1 + i) \cdot 2} = -\frac{i}{8} \frac{1}{1 + i}.$$

Correspondingly, at $z = -1 + i$, we write

$$\frac{1}{(z^2 + 2)^2 - 4z^2} = \frac{1}{z + 1 - i} \left[\frac{1}{(-1 + i - 1 + i)(-1 + i - 1 - i)(-1 + i + 1 + i)} + \dots \right]$$

which gives

$$\frac{1}{2(-1 + i) \cdot (-2) \cdot 2i} = \frac{i}{8} \frac{1}{(-1 + i)}.$$

Thus

$$\oint_C \frac{dz}{(z^2 + 2)^2 - 4z^2} = 2\pi i \left[-\frac{i}{8} \frac{1}{(1 + i)} + \frac{i}{8} \frac{1}{(-1 + i)} \right] = 2\pi i \cdot \frac{i}{8} \left(\frac{1 - i + 1 + i}{-2} \right) = \frac{\pi}{4}$$

Excellent Economics and Business programmes at:



university of
 groningen



**“The perfect start
of a successful,
international career.”**

CLICK HERE
to discover why both socially
and academically the University
of Groningen is one of the best
places for a student to be

www.rug.nl/feb/education

$$= \int_{-R}^R \frac{dx}{(x^2 + 2)^2 - 4x^2} + \int_{sc} \frac{dz}{(z^2 + 2)^2 - 4z^2}$$

$$\rightarrow \int_{-\infty}^{\infty} \frac{dx}{(x^2 + 2)^2 - 4x^2} \text{ as } R \rightarrow \infty$$

by virtue of the given condition; so we have $\int_{-\infty}^{\infty} \frac{dx}{(x^2 + 2)^2 - 4x^2} = \frac{\pi}{4}$.

Notes: In this exercise, we have seen that the integrand has four simple poles, only two of which sit inside the semi-circular region in the upper half-plane. In order to complete the (mathematical) argument – which we were not asked to supply – we would need to show that the integral along the semicircle tends to zero as its radius increases. To do this, we note that the relevant triangle inequality is based on

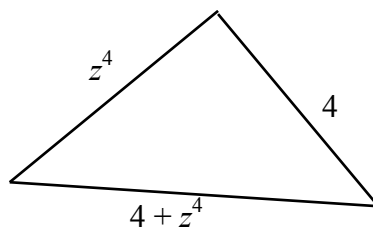

and so

$$\left| (z^2 + 2)^2 - 4z^2 \right| + 4 = \left| 4 + z^4 \right| + 4 \geq \left| z^4 \right| = R^4 \text{ (on the semicircle);}$$

thus $\left| 4 + z^4 \right| \geq R^4 - 4$ and then $\frac{1}{\left| 4 + z^4 \right|} \leq \frac{1}{R^4 - 4}$.

Hence we obtain

$$\left| \int_{sc} \frac{dz}{(z^2 + 2)^2 - 4z^2} \right| \leq \int_0^\pi \frac{R d\theta}{R^4 - 4} = \frac{\pi R}{R^4 - 4} \rightarrow 0 \text{ as } R \rightarrow \infty,$$

as required.

It is also possible to use these techniques – integration in the complex plane – to evaluate another class of integrals:

$$\int_0^{2\pi} F(\sin \theta, \cos \theta) d\theta.$$

However, in this case, we construct the corresponding problem simply by invoking a change of integration variable (which is a very familiar method in classical, real integration). Thus there is no requirement here to analyse integrals on parts of the contour, as some limit is taken. We introduce $z = e^{i\theta}$, so that

$$\cos \theta = \frac{1}{2} \left(z + \frac{1}{z} \right), \quad \sin \theta = \frac{1}{2i} \left(z - \frac{1}{z} \right),$$

with $z = ie^{i\theta} = i$; then $0 \leq \theta \leq 2\pi$ becomes the integral around the circle of radius 1, centred at the origin (often called the *unit circle*).

Example 34 *Real integral III.* Find the value of $\int_0^{2\pi} \frac{d\theta}{5+4\sin\theta}$.

We use the transformation to give

$$\int_0^{2\pi} \frac{d\theta}{5+4\sin\theta} = \oint_{\odot} \frac{\frac{1}{iz} dz}{5+4 \cdot \frac{1}{2i} \left(z - \frac{1}{z} \right)} = \oint_{\odot} \frac{dz}{5iz+2(z^2-1)} = \oint_{\odot} \frac{dz}{2 \left(z^2 + \frac{5i}{2}z - 1 \right)},$$

where the symbol on the integral denotes the unit circle – the contour used here. But we note that

$$z^2 + \frac{5}{2}iz - 1 = (z + 2i)(z + \frac{1}{2}i),$$

which shows that we have a single simple pole inside the contour, at $z = -\frac{1}{2}i$; the residue at this pole is obtained by writing

$$\frac{1}{2 \left(z^2 + \frac{5i}{2}z - 1 \right)} = \frac{1/[2(z + 2i)]}{z + \frac{1}{2}i},$$

and e.g. invoking the Cauchy Integral Formula we get the residue $\frac{1}{2} \cdot \frac{1}{3i/2} = \frac{1}{3i}$.

Thus

$$\int_0^{2\pi} \frac{d\theta}{5+4\sin\theta} = \oint_{\odot} \frac{dz}{2 \left(z^2 + \frac{5i}{2}z - 1 \right)} = 2\pi i \cdot \frac{1}{3i} = \frac{2}{3} \pi.$$

7.3 Using a different contour

The essential skill in using these techniques (particularly for the evaluation of real integrals) is finding the right/appropriate choice of contour for the problem under consideration. Let us attempt to find, for example,

$$\int_{-\infty}^{\infty} \frac{\sin x}{x} dx$$

using these new techniques. When expressed as a suitable function in the complex plane, we would write

$$\oint_C \frac{e^{iz}}{z} dz;$$

this is chosen, rather than the integrand $\sin z/z$, because we must ensure suitable decay conditions for large distances away from the origin. This is discussed in §5.4 (Jordan’s Lemma), where the necessity of using the exp function, rather than sin, is made clear. However, this is a surprising choice in the light of another crucial property of the original integrand: the function $\sin x/x$ is integrable – otherwise the integral would not exist! – and one essential reason for this is that $\sin x/x$ has a finite limit as $x \rightarrow 0$. (The confirmation that this function is integrable at infinity is not so easily checked; we will not dwell upon that here.) The function $\sin z/z$ possesses the same property as $z \rightarrow 0$, but e^{iz}/z does not; this integrand is not defined at $z = 0$ and, consequently, the value of the integral diverges (logarithmically) as $z \rightarrow 0$. The upshot of this is that $z = 0$ must be avoided: the conventional semi-circular contour, which obviously passes through the origin, cannot be used. The contour that we choose, for this type of problem, is the semi-circular boundary (encircling the poles in the upper-half plane) but with an indent around $z = 0$:

In the past four years we have drilled
89,000 km
 That's more than **twice** around the world.

Who are we?
 We are the world's largest oilfield services company¹.
 Working globally—often in remote and challenging locations—we invent, design, engineer, and apply technology to help our customers find and produce oil and gas safely.

Who are we looking for?
 Every year, we need thousands of graduates to begin dynamic careers in the following domains:

- Engineering, Research and Operations
- Geoscience and Petrotechnical
- Commercial and Business

What will you be?

Schlumberger

careers.slb.com

¹Based on Fortune 500 ranking 2011. Copyright © 2015 Schlumberger. All rights reserved.



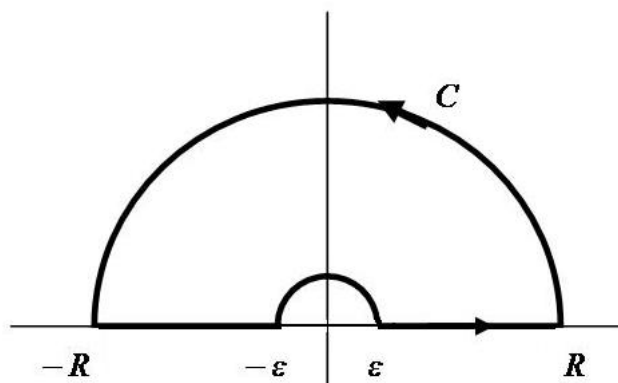

As we see, the part of the contour along the real axis now goes around (via a semicircle of radius ϵ) the singularity at the origin; indeed, this particular choice ensures that this singularity is now *outside* the contour. To apply our general approach, we need to take two limits: $R \rightarrow \infty$ and $\epsilon \rightarrow 0$; this idea is developed in the next example.

Example 35 *A different contour.* Evaluate $\int_{-\infty}^{\infty} \frac{\sin x}{x} dx$ by using an indented semi-circular contour.

We consider, as described above, the integral $\oint_C \frac{e^{iz}}{z} dz$ and the corresponding indented contour in the figure. This integrand has a simple pole at $z = 0$, but this is *outside* the chosen contour, so we have immediately (Cauchy's Integral Theorem)

$$\oint_C \frac{e^{iz}}{z} dz = 0.$$

Thus we have

$$\int_{-R}^{-\epsilon} \frac{e^{ix}}{x} dx + \int_{sc\epsilon} \frac{e^{iz}}{z} dz + \int_{\epsilon}^R \frac{e^{ix}}{x} dx + \int_{sc} \frac{e^{iz}}{z} dz = 0,$$

where $sc\epsilon$ denotes the semicircle around the origin, and sc the larger semicircle (of radius R); we know (Jordan's Lemma, §5.4) that the integral on this larger radius tends to zero as the radius increases.

Now we examine the contribution from the smaller semicircle. On this part of the contour, write $z = \epsilon e^{i\theta}$, $\pi \geq \theta \geq 0$ (and note the direction), to give

$$\begin{aligned} \int_{sc\epsilon} \frac{e^{iz}}{z} dz &= \int_{\pi}^0 \frac{\exp(i\epsilon e^{i\theta})}{\epsilon e^{i\theta}} \epsilon e^{i\theta} d\theta = i \int_{\pi}^0 \exp(i\epsilon e^{i\theta}) d\theta \\ &\rightarrow i \int_{\pi}^0 d\theta = -i\pi \text{ as } \epsilon \rightarrow 0. \end{aligned}$$

(We can note that the answer here is, perhaps, what we might have guessed – or hoped for: it is half the value obtain by going once around ($2\pi i$) and in the opposite direction.) In addition, we also take $R \rightarrow \infty$ (with Jordan’s Lemma invoked) to give

$$\oint_{-\infty}^{\infty} \frac{e^{ix}}{x} dx - i\pi = 0,$$

where the bar on the integral sign indicates that the principal value has been taken; this is necessary here because the evaluation requires a limiting process ($\varepsilon \rightarrow 0$) to obtain the value of an integral that, in the conventional sense, is not defined. (This is sometimes written as $\mathcal{P} \int$ or $PV \int$.) Thus we have

$$\oint_{-\infty}^{\infty} \frac{e^{ix}}{x} dx = i\pi$$

and then the imaginary part gives

$$\int_{-\infty}^{\infty} \frac{\sin x}{x} dx = \pi,$$

where the bar on the integral is no longer required because this integral does exist in the conventional sense – but the real part (involving \cos) – does not.

Comment: In this exercise, we have had to introduce the notion of the *principal value* of an integral. This is required when the integral, in the conventional sense, is not defined, but a value can be obtained *via* a (special) limiting process. This idea is explored more fully in Part II of this text.

Exercises 7

- 36. Use the Residue Theorem to evaluate $\oint_C f(z) dz$, where C is the contour $|z| = 3$, mapped counter-clockwise, with $f(z)$ chosen to be each function given in Exercise 35 (in Exercises 6).
- 37. Evaluate the integral $\oint_C \frac{1+z}{(z^2 + 2z + 2)(z^2 - 2z + 5)} dz$, where C is the square with vertices at the points $z = 0, 5, 5(1+i), 5i$, mapped counter-clockwise.
- 38. Evaluate the integral $\oint_C \frac{4-3z}{z^2 - z} dz$, where C , mapped counter-clockwise, is a closed contour with the properties:
 - (a) the points $z = 0$ and $z = 1$ are both outside;
 - (b) the point $z = 0$ is outside and $z = 1$ is inside;
 - (c) the point $z = 0$ is inside and $z = 1$ is outside;

(d) the points $z = 0$ and $z = 1$ are both inside.

39. Evaluate the integral $\oint_C \frac{2+3z^3}{(z-1)(9+z^2)} dz$, where C , mapped counter-clockwise, is the closed contour:

(a) $|z| = 2$; (b) $|z - 2| = 2$; (c) any Jordan curve satisfying $|z| > 3$.

40. Introduce a suitable semi-circular contour in the complex plane, and hence evaluate these real integrals. (In all cases, you may assume that a correctly-chosen contour ensures that the integral along the semi-circular arc tends to zero as its radius is increased to infinity, but see Exercise 42 below.)

(a) $\int_{-\infty}^{\infty} \frac{dx}{(x^2+1)(x^2+4)}$; (b) $\int_0^{\infty} \frac{x^2}{(x^2+1)(x^2+4)} dx$; (c) $\int_{-\infty}^{\infty} \frac{x}{(x^2+1)(x^2+2x+2)} dx$;
 (d) $\int_0^{\infty} \frac{\cos x}{x^2+1} dx$; (e) $\int_0^{\infty} \frac{\cos(ax)}{x^2+1} dx$ ($a \geq 0$); (f) $\int_{-\infty}^{\infty} \frac{\sin x}{x^2+4x+5} dx$; (g) $\int_0^{\infty} \frac{x \sin x}{(x^2+1)(x^2+4)} dx$;

(h) $\int_{-\infty}^{\infty} \frac{e^{i\alpha x}}{x^2+4} dx$ ($\alpha \geq 0$, real); (i) $\int_{-\infty}^{\infty} \frac{e^{i\alpha x} \sin x}{x^2+1} dx$ ($\alpha \geq 1$, real).

41. See Exercise 40(a); now give all the mathematical details that were omitted i.e. show that the integral along the semi-circular arc does indeed tend to zero as the radius increases.

American online

LIGS University

is currently enrolling in the
Interactive Online **BBA, MBA, MSc,**
DBA and PhD programs:

- ▶ enroll **by September 30th, 2014** and
- ▶ **save up to 16%** on the tuition!
- ▶ pay in 10 installments / 2 years
- ▶ Interactive **Online education**
- ▶ visit www.ligsuniversity.com to find out more!

Note: LIGS University is not accredited by any nationally recognized accrediting agency listed by the US Secretary of Education. More info [here](#).





42. See Exercise 39(c); consider a contour that is extended to infinity in all directions i.e. $|z| \rightarrow \infty$ on C . Now any pole at a fixed point, $z = z_0$, will have a residue if a term of the form $1/(z - z_0)$ is present; however, every such term approaches the form $1/z$ as $|z| \rightarrow \infty$. Thus, if a contour encircles all the poles of a function, the coefficient of the term $1/z$ in the expansion of the function as $|z| \rightarrow \infty$ will recover the sum of all the residues at all poles inside the contour. Expand the integrand for $|z| \rightarrow \infty$, find the coefficient of the term $1/z$, apply the Residue Theorem and compare your answer with that obtained previously for Exercise 39(c).

43. Evaluate these real integrals:

$$(a) \int_0^{2\pi} \frac{d\theta}{5 - 3\cos\theta}; (b) \int_0^{2\pi} \frac{\cos^2 \theta}{26 - 10\cos 2\theta} d\theta; (c) \int_0^{\pi} \frac{d\theta}{k + \cos\theta} \quad (k > 1).$$

44. Consider the integral

$$I(s) = \oint_C z^{-s} e^z dz,$$

where the contour, C , shown below, is mapped counter-clockwise (and the left-hand closure extends to the left, as necessary, to enclose any poles). [Note that, once the relevant poles have been enclosed, then the left closure may be moved to infinity, leftwards.]

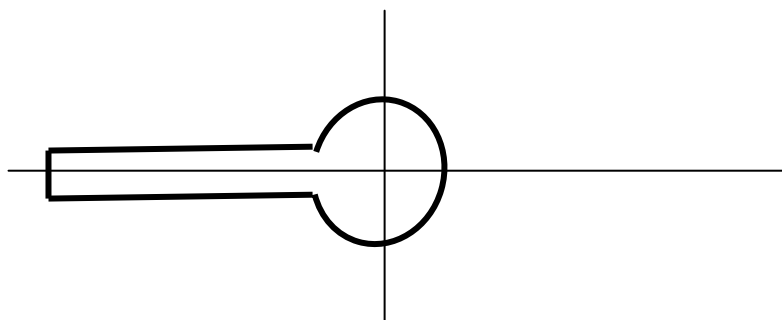

Evaluate $I(s)$ when s is an integer; you should consider both positive and negative values of s .

8 The Fourier Transform

Many physical systems involve motions such as vibrations, or oscillations, of one sort or another; these types of problems arise in physics, applied mathematics and engineering. The study of these systems usually requires the production, and analysis, of signals and associated spectra, but these will rarely be described in terms of simple sine waves; they are more likely to contain general oscillatory motions, and perhaps other (non-oscillatory) components. Such output (data) is most readily examined by taking a suitable transform; indeed, there are important branches of (mainly) physics which work solely with the transform, rather than the original function (i.e. the physical data). The one we discuss here is probably the most useful and most powerful: the Fourier Transform, which is based on the familiar ideas that underpin the Fourier series (used, for example, in the construction of solutions of constant coefficient, linear partial differential equations). Indeed, we develop this particular idea to give an outline argument that demonstrates how a Fourier series can be generalised and extended to an integral transform.

We start with the familiar identity

$$e^{\pm inx} = \cos(nx) \pm i \sin(nx),$$

which is used to produce the expressions (§2.1(d))

$$\sin(nx) = \frac{1}{2i} (e^{inx} - e^{-inx}); \quad \cos(nx) = \frac{1}{2} (e^{inx} + e^{-inx}).$$

Thus the terms in a Fourier series can be written as

$$\begin{aligned} a_n \cos\left(\frac{n\pi}{\ell} x\right) + b_n \sin\left(\frac{n\pi}{\ell} x\right) &= \frac{1}{2} a_n (e^{in\pi x/\ell} + e^{-in\pi x/\ell}) + \frac{1}{2i} (e^{in\pi x/\ell} - e^{-in\pi x/\ell}) \\ &= A_n e^{in\pi x/\ell} + B_n e^{-in\pi x/\ell}, \end{aligned}$$

where

$$\begin{aligned} A_n &= \frac{1}{2} (a_n - ib_n) = \frac{1}{2} \left(\frac{1}{\ell} \int_{-\ell}^{\ell} f(x) \cos\left(\frac{n\pi}{\ell} x\right) dx - i \frac{1}{\ell} \int_{-\ell}^{\ell} f(x) \sin\left(\frac{n\pi}{\ell} x\right) dx \right) \\ &= \frac{1}{2\ell} \int_{-\ell}^{\ell} f(x) e^{-in\pi x/\ell} dx. \end{aligned}$$

Similarly, we see that

$$B_n = \frac{1}{2\ell} \int_{-\ell}^{\ell} f(x) e^{in\pi x/\ell} dx.$$

Then, introducing $c_n = A_n$ ($n > 0$), $c_{-n} = B_n$ ($n > 0$) and $c_0 = a_0/2$, we may write

$$f(x) = \sum_{n=-\infty}^{\infty} c_n e^{in\pi x/\ell} \quad \text{where} \quad c_n = \frac{1}{2\ell} \int_{-\ell}^{\ell} f(x) e^{-in\pi x/\ell} dx.$$

We now examine how we might apply these results to functions which are *not periodic* i.e. general functions. This amounts to allowing $\ell \rightarrow \infty$; how can we do this?

First, let us write

$$2\ell c_n = \int_{-\ell}^{\ell} f(x) e^{-in\pi x/\ell} dx = F\left(\frac{n\pi}{\ell}\right),$$

then we have

$$f(x) = \sum_{n=-\infty}^{\infty} \frac{1}{2\ell} F\left(\frac{n\pi}{\ell}\right) e^{in\pi x/\ell} = \frac{1}{2\pi} \sum_{n=-\infty}^{\infty} \frac{\pi}{\ell} F\left(\frac{n\pi}{\ell}\right) e^{in\pi x/\ell}.$$

This latter expression, in the limit as $\ell \rightarrow \infty$, gives

$$f(x) = \frac{1}{2\pi} \int_{-\infty}^{\infty} F(k) e^{ikx} dk \quad \text{and, correspondingly,} \quad F(k) = \int_{-\infty}^{\infty} f(x) e^{-ikx} dx;$$

the second expression is the *Fourier Transform* of $f(x)$, and the first is its *inverse*.

.....Alcatel-Lucent 

www.alcatel-lucent.com/careers



What if you could build your future and create the future?

One generation's transformation is the next's status quo. In the near future, people may soon think it's strange that devices ever had to be "plugged in." To obtain that status, there needs to be "The Shift".



Thus we have, given a suitable function – the relevant integral must exist, of course – the Fourier Transform (FT) defined by

$$F(k) = \int_{-\infty}^{\infty} f(x) e^{-ikx} dx \quad (\text{for a real parameter } k),$$

and the inverse FT then becomes

$$f(x) = \frac{1}{2\pi} \int_{-\infty}^{\infty} F(k) e^{ikx} dk.$$

These two integrals are line integrals along the appropriate real axes.

It is of some importance to note that there is some variation in the definitions used – and the particular one used in any texts that might be read needs to be checked. A common alternative, considered by many authors, is obtained by replacing f by $f/\sqrt{2\pi}$, which gives the so-called *symmetric* transform and its inverse.

Note: Not only is this a useful tool in many branches of mathematics, physics and engineering (where, as we mentioned above, it is sometimes more convenient to work in ‘Fourier space’ i.e. use k directly, rather than physical space), but also as a technique in its own right. Thus this construct can be used to find solutions of various types of linear, ordinary and partial differential equations, as well as certain integral equations.

We will work through three examples, two to find $F(k)$ and one to find an inverse i.e. given $F(k)$, find $f(x)$. In conclusion, we will then hint at how the method can be adapted to solve differential equations by seeing how derivatives behave under the Fourier transform.

Example 36 *Fourier Transform I.* Find the Fourier Transform of

$$f(x) = \begin{cases} 1, & 0 \leq x \leq 1, \\ -1, & -1 \leq x < 0, \\ 0, & \text{otherwise.} \end{cases}$$

Thus we have $F(k) = \int_{-1}^0 (-1)e^{-ikx} dx + \int_0^1 (1)e^{-ikx} dx$

$$= \left[\frac{1}{ik} e^{-ikx} \right]_{-1}^0 + \left[-\frac{1}{ik} e^{-ikx} \right]_0^1 = -\frac{i}{k} (1 - e^{ik}) + \frac{i}{k} (e^{-ik} - 1)$$

$$= -\frac{2i}{k} + \frac{i}{k} (e^{-ik} + e^{ik}) = \frac{2i}{k} (\cos k - 1).$$

We observe here that the given function is odd, and the resulting FT is also odd (and pure imaginary).

Example 37 *Inverse transform.* Find the inverse Fourier Transform of

$$F(k) = \frac{1}{1+k^2}.$$

Here, we require the evaluation $f(x) = \frac{1}{2\pi} \int_{-\infty}^{\infty} \frac{e^{ikx}}{1+k^2} dk$, with the familiar semi-circular contour that encloses the pole (at $k = i$) in the upper-half plane; we consider, first, $x > 0$. The residue at $k = i$ is $\frac{e^{i \cdot ix}}{i+i}$, and so the value of the integral is $2\pi i \frac{e^{-x}}{2i} = \pi e^{-x}$. Thus we have

$$\oint_C \frac{e^{izx}}{1+z^2} dz = \int_{-R}^R \frac{e^{ikx}}{1+k^2} dk + \int_{sc} \frac{e^{izx}}{1+z^2} dz = \pi e^{-x},$$

and the integral on the semi-circular arc (sc) tends to zero as $R \rightarrow \infty$ (because the real part of the exponent is $i \cdot iyx = -xy < 0$ for $x > 0$). Thus

$$f(x) = \frac{1}{2\pi} \pi e^{-x} = \frac{1}{2} e^{-x} \quad (x > 0);$$

the corresponding calculation for $x < 0$, using the lower-half plane, gives $\frac{1}{2} e^x$ and so the final result is

$$f(x) = \frac{1}{2} e^{-|x|}.$$

In this final example, we find another FT, and then formulate (but not evaluate from first principles) the inverse, and use this to obtain the value of a standard real integral – a very powerful, general mathematical technique.

Example 38 *Fourier Transform II.* Find the Fourier Transform of

$$f(x) = \begin{cases} 1, & |x| \leq 1, \\ 0, & |x| > 1. \end{cases}$$

Now evaluate the inverse on $x = 0$ and hence obtain an important identity.

Here we have

$$\begin{aligned} F(k) &= \int_{-1}^1 1 \cdot e^{-ikx} dx = -\frac{1}{ik} \left[e^{-ikx} \right]_{-1}^1 \\ &= \frac{i}{k} (e^{-ik} - e^{ik}) = \frac{i}{k} \cdot -2i \sin k = \frac{2}{k} \sin k. \end{aligned}$$

Now we formulate the inverse: $\frac{1}{2\pi} \int_{-\infty}^{\infty} \frac{2}{k} (\sin k) e^{ikx} dk = \begin{cases} 1, & |x| \leq 1 \\ 0, & |x| > 1 \end{cases}$

and evaluating this on $x = 0$ yields immediately the result

$$\int_{-\infty}^{\infty} \frac{\sin k}{k} dk = \pi .$$

Note: In this example, the function is even, and the FT is also even (and real). The last part of the calculation, we see, produces the value of the integral $\int_{-\infty}^{\infty} \frac{\sin x}{x} dx$; this new technique is far simpler than the one adopted in Example 35!

8.1 FTs of derivatives

We conclude by mentioning how derivatives are transformed; this would be the start of a discussion of how this transform can be used to construct solutions of some classes of ordinary and partial differential equations (but this will not be developed here). Suppose that we are given a function $y'(x)$, then we take the FT:

$$\begin{aligned} \int_{-\infty}^{\infty} y'(x) e^{-ikx} dx &= \left[y(x) e^{-ikx} \right]_{-\infty}^{\infty} - \int_{-\infty}^{\infty} y(x) (-ik) e^{-ikx} dx \\ &= ikY(k), \end{aligned}$$



Join the best at the Maastricht University School of Business and Economics!

Top master's programmes

- 33rd place Financial Times worldwide ranking: MSc International Business
- 1st place: MSc International Business
- 1st place: MSc Financial Economics
- 2nd place: MSc Management of Learning
- 2nd place: MSc Economics
- 2nd place: MSc Econometrics and Operations Research
- 2nd place: MSc Global Supply Chain Management and Change

Sources: Keuzegids Master ranking 2013; Elsevier 'Beste Studies' ranking 2012; Financial Times Global Masters in Management ranking 2012

Maastricht University is the best specialist university in the Netherlands (Elsevier)

Visit us and find out why we are the best!
Master's Open Day: 22 February 2014

www.mastersopenday.nl



provided that $y \rightarrow 0$ as $|x| \rightarrow \infty$, and where $Y(k)$ is the FT of $y(x)$; of course, it is assumed that the integrals defining both $y'(x)$ and $y(x)$ exist. This result, with suitable decay and existence conditions, generalises to $(ik)^n Y(k)$ for the FT of $y^{(n)}(x)$.

These results, for the various derivatives, are the basis for solving suitable ODEs and PDEs. Corresponding results for integrals (including the FT of a convolution) enable integral equations to be solved. These ideas are explored in any good text on transform methods.

Exercises 8

45. Find the Fourier Transform of the function

$$f(x) = \begin{cases} x, & 0 \leq x \leq a, \\ 0, & x < 0, \quad x > a \end{cases}$$

where $a > 0$ is a constant.

46. Find the Fourier Transform of the function

$$f(x) = \begin{cases} x^2, & |x| \leq a, \\ 0, & |x| > a \end{cases}$$

where $a > 0$ is a constant.

47. Find the Fourier transform of the function $f(x) = \frac{a}{a^2 + x^2}$, $-\infty < x < \infty$, where $a > 0$ is a constant.

48. Find the Fourier Transform of the function

$$f(x) = \begin{cases} e^{-ax}, & x \geq 0 \\ 0, & x < 0 \end{cases}$$

where $a > 0$ is a constant. Hence, from the inverse transform, show that

$$\int_0^{\infty} \frac{\cos k}{a^2 + k^2} dk = \frac{\pi}{2a} e^{-a} \dots$$

[Hint: evaluate on $x = \pm 1$.]

49. Evaluate the Inverse Fourier Transform,

$$f(x) = \frac{1}{2\pi} \int_{-\infty}^{\infty} F(k) e^{ikx} dk, \quad x \geq 0,$$

by using the residue theorem, for these functions (a and ε both real and positive)

$$(a) F(k) = \frac{1}{k^2 + a^2}; \quad (b) F(k) = \frac{1}{k^2 - a^2 + i\varepsilon} \quad \text{with } \varepsilon \rightarrow 0.$$

Answers

Exercises 1

1 (a) $|z_1| = \sqrt{2}, |z_2| = \sqrt{13}, |z_1 z_2| = \sqrt{26}, \bar{z}_1 = -1 - i, z_1 \bar{z}_1 = 2;$

(b) $\frac{z_2}{z_1} = \frac{1}{2}(1 - 5i), \frac{1}{z_2} = \frac{1}{13}(2 - 3i), \frac{z_1 - z_2}{z_1 + z_2} = \frac{1}{17}(-11 + 10i).$

2

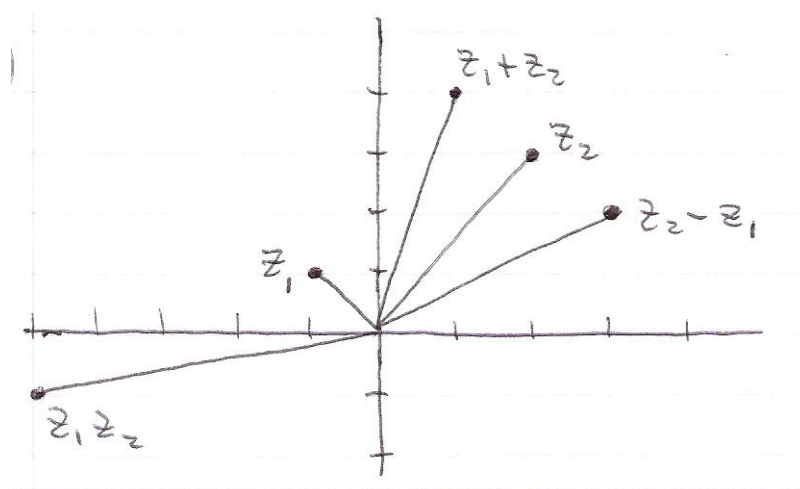

3 (a) $|z_1| = \sqrt{2}, |z_2| = \sqrt{13}, |z_1 + z_2| = \sqrt{17}, |z_1 - z_2| = \sqrt{13};$

(b) $|z_1| = \sqrt{5}, |z_2| = \sqrt{10}, |z_1 + z_2| = 5, |z_1 - z_2| = \sqrt{5}.$

4

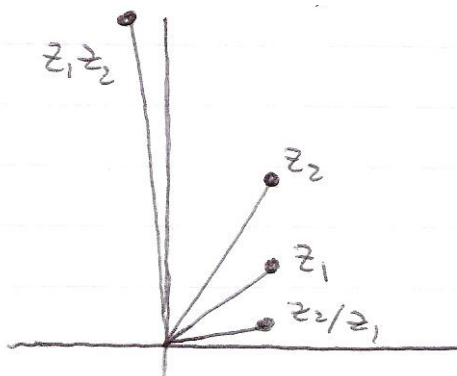

- 5 (a) modulus = 1, arg = π ; (b) modulus = 1, arg = $\pi/2$; (c) modulus = $\sqrt{2}$, arg = $\pi/4$;
 (d) modulus = $\sqrt{2}$, arg = $-\pi/4$ (or $7\pi/4$); (e) modulus = 1, arg = $\pi/2$;
 (f) modulus = 1, arg = $-\pi/2$ (or $3\pi/2$).
- 6 (a) $2.e^{i\pi/2}$; (b) $1.e^{i\pi}$; (c) $\sqrt{2}.e^{i3\pi/4}$; (d) $2.e^{i\pi/3}$.
- 7 (a) $i, -1, \frac{1}{\sqrt{2}}(1-i)$; (b) $i, -i, 1$.
- 8 (a) $1, i, -1, -i$; (b) $e^{i\pi/4}, e^{i3\pi/4}, e^{i5\pi/4}, e^{i7\pi/4}$; (c) $e^{-i\pi/4}, e^{i3\pi/4}$; (d) $3e^{-i\pi/6}, 3e^{i\pi/2}, 3e^{i7\pi/6}$.
- 9 $e^{i\pi/3}, e^{i\pi}, e^{i5\pi/3} = e^{-i\pi/3}$ i.e. $\frac{1}{2}(1+i\sqrt{3}), -1, \frac{1}{2}(1-i\sqrt{3})$; the zeros arise because of the zero coefficients in the cubic $z^3 + 0.z^2 + 0.z + 1 = 0$.

Exercises 2

- 10 (a) $(x \cos y - y \sin y)e^x + i(y \cos y + x \sin y)e^x$; (b) $x^2 - y^2 + y + i(2y - 1)x$;
 (c) $-4ixy$; (d) $\frac{x^2 - y^2}{x^2 + y^2} + i \frac{2xy}{x^2 + y^2}$.



> Apply now

REDEFINE YOUR FUTURE
**AXA GLOBAL GRADUATE
 PROGRAM 2015**

redefining / standards 

agence c4g - © Photonistop

- 11 (a) $2x^3 - 6xy^2 + 2xy + i(6x^2y - 2y^3 - x^2 + y^2)$;
 (b) $x \cosh y \sin x - y \sinh y \cos x + i(x \sinh y \cos x + y \cosh y \sin x)$;
 (c) $x \cosh x \cos y - y \sinh x \sin y + i(y \cosh x \cos y + x \sinh x \sin y)$;
 (d) $x^4 - 6x^2y^2 + y^4 + i4xy(x^2 - y^2)$; (e) $\frac{1-x^2-y^2}{(1-x)^2+y^2} + i\frac{2y}{(1-x)^2+y^2}$.
- 12 (a) $i(\frac{1}{4} + n)\pi$, $n = 0, \pm 1, \pm 2, \dots$; (b) $1 - \frac{1}{2}i\pi$; (c) $\frac{1}{2} \ln 2 - \frac{1}{4}i\pi$;
 (d) $e^{-\frac{\pi}{4} - 2n\pi} \left[\cos\left(\frac{1}{2} \ln 2\right) + i \sin\left(\frac{1}{2} \ln 2\right) \right]$, $n = 0, \pm 1, \pm 2, \dots$.
- 13 (a) $e^{-\pi/4} \left[\cos\left(\frac{1}{2} \ln 2\right) + i \sin\left(\frac{1}{2} \ln 2\right) \right]$; (b) $\cos(\ln 2) + i \sin(\ln 2)$; (c) $\frac{1}{2} \ln 2 - i\pi/4$;
 (d) $e^\pi \left[\cos(2 \ln 2) + i \sin(2 \ln 2) \right]$.
- 15 (a) $z = \ln 3 \pm i(1 + 2n)\pi$, $n = 0, 1, 2, \dots$; (b) $z = i$;
 (c) $z = \frac{1}{2}(1 + 4n)\pi + i \ln(2 \pm \sqrt{3})$, $n = 0, \pm 1, \pm 2, \dots$; (d) $z = i(1 + 2n)\pi$, $n = 0, \pm 1, \pm 2, \dots$.
- 16 (a) $z = in\pi$, $n = 0, \pm 1, \pm 2, \dots$; (b) $z = i\frac{1}{2}(1 + 2n)\pi$, $n = 0, \pm 1, \pm 2, \dots$.
- 17 (a) $z = \frac{1}{2} \ln\left(\frac{1+k}{1-k}\right) + in\pi$, $n = 0, \pm 1, \pm 2, \dots$; (b) no solution exists;
 (c) $z = \frac{1}{2} \ln\left(\frac{k+1}{k-1}\right) + \frac{1}{2}i(1+2n)\pi$, $n = 0, \pm 1, \pm 2, \dots$.
- 18 (a) $\sin x \cosh y + i \cos x \sinh y$; (b) $\cos x \cosh y - i \sin x \sinh y$;
 (c) $\sinh x \cos y + i \cosh x \sin y$; (d) $\cosh x \cos y + i \sinh x \sin y$;
 (e) $\frac{\sin 2x + i \sinh 2y}{\cos 2x + \cosh 2y}$; (f) $\frac{\sinh 2x + i \sin 2y}{\cosh 2x + \cos 2y}$; then $\tan(ix) = i \tanh x$, $\tanh(ix) = i \tan x$.
- 19 (a) $\sqrt{\pi}$; (b) $\frac{1}{2}\sqrt{\pi}$; (c) $-2\sqrt{\pi}$.

Exercises 3

- 20 (a) Yes; (b) No; (c) No; (d) No, except along the line $y = x$; (e) No; (f) Yes; (g) No.
- 21 (a) $f(z) = 2z + iz^2 + iC$ (C is an arbitrary real constant); (b) $f(z) = 2z - z^3 + iC$ (ditto); (c) $f(z)$ does not exist; (d) ditto; (e) $-\frac{1}{2}iz^2 + iC$ (C as earlier); (f) $f(z) = -(1+i)z + iC$ (ditto); (g) $f(z) = -z^2 + iC$ (ditto).

- 24 (a) $-\sin z$; (b) $\cosh z$.
- 25 (a) $\phi(x, y) = (x \cos 2y - y \sin 2y)e^{2x}$, $\phi(x, y) = (y \cos 2y + x \sin 2y)e^{2x}$;
 (b) $\phi(x, y) = x^4 - 6x^2y^2 + y^4$, $\phi(x, y) = 4(x^2 - y^2)xy$;
 (c) $\phi(x, y) = (x^2 - y^2)\sin x \cosh y - 2xy \cos x \sinh y$,
 $\phi(x, y) = 2xy \sin x \cosh y + (x^2 - y^2)\cos x \sinh y$;
 (d) $\phi(x, y) = (\cos x \cos y \cosh y + \sin x \sin y \sinh y)e^x$,
 $\phi(x, y) = (\cos x \sin y \cosh y - \sin x \cos y \sinh y)e^x$.

Exercises 4

- 26 (a) 4; (b) 0; (c) $\cos 3 - 1$; (d) $i\pi a^2$; (e) $e^{i(s+1)\pi}\Gamma(s+1)$.
- 27 (a) $-\frac{1}{3} + i\frac{11}{6}$; (b) $1 + \frac{1}{2}i$; (c) $-2 + i\frac{5}{2}$; (d) $\frac{2}{15} + i\frac{3}{2}$.
- 28 All four answers are $-2 - i\frac{3}{2}$, because $y - ix = -iz$ is an analytic function.
- 29 (a) $-\frac{1}{3}i$; (b) $1 - \cosh \pi$; (c) $(1 - \cos 1 - i \sin 1)e^{-1}$; (d) 0.
- 30 (a) $-\frac{1}{2}\ln 2 + i[\arctan(2) + \arctan(3)]$; (b) $\frac{1}{2}\ln 2 + i[\arctan(2) + \arctan(3)]$; (c) $i\frac{1}{2}\pi$; the contour is shown in the figure, and the integral all around is then

$$-\frac{1}{2}\ln 2 + i\frac{3}{4}\pi + \frac{1}{2}\ln 2 + i\frac{3}{4}\pi + i\frac{1}{2}\pi = 2\pi i.$$

Note that

$$\begin{aligned} \arctan(2) + \arctan(3) &= \pi + \arctan\left(\frac{2+3}{1-2\cdot 3}\right) \\ &= \pi + \arctan(-1) = \frac{3}{4}\pi \end{aligned}$$

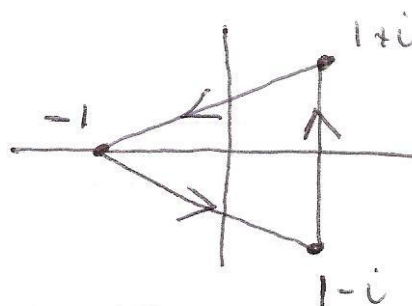

Exercises 5

- 31 (a) 0; (b) 0; (c) $\frac{1}{2}\pi i$; (d) $2\pi i$; (e) 0; (f) πi ; (g) $-\frac{1}{2}\pi i$; (h) $-\frac{1}{12}\pi i$; (i) $\frac{1}{2}\pi i$; (j) 0;
 (k) $\frac{1}{126}\pi i$; (l) $\frac{2}{5}i\pi e^{1/2}$; (m) $\frac{2}{3}\pi$.

- 32 (a) -2π ; (b) 0; (c) $\frac{1}{5}\pi(1 + e^\pi)(1 + 2i)$; (d) $\frac{2}{5}\pi(1 - 3i)$; (e) 0.
- 33 (a) $-\frac{2\pi}{a}i$ for $|a| > 1$, and 0 for $|a| < 1$; (b) evaluate on the unit circle (as the problem implies) because the given function is not analytic; the exercise then repeats (a).

Exercises 6

- 34 (a) $\frac{1}{z^2} - \sum_{n=-1}^{\infty} (-z)^n$; (b) $\frac{1}{4z} \sum_{n=0}^{\infty} (z/4)^n$; (c) $-\frac{1}{2} \left\{ \frac{1}{z-1} + \frac{3}{2} \sum_{n=0}^{\infty} \left(\frac{z-1}{2} \right)^n \right\}$
- (d) $\frac{1}{z} \sum_{n=0}^{\infty} \frac{1}{z^n} + \frac{1}{2} \sum_{n=0}^{\infty} (z/2)^n$; (e) $\frac{1}{10}(2-i) \sum_{n=0}^{\infty} (-z/2)^n + \frac{1}{5z}(3+i) \sum_{n=0}^{\infty} (i/z)^n$;
- (f) $\frac{2}{z-1} \sum_{n=0}^{\infty} (-2/(z-1))^n + \sum_{n=0}^{\infty} \left(-\frac{1}{3}(z-1) \right)^n$.
- 35 (a) $z = 0$, res 1; (b) $z = 1$, res -2 ; (c) $z = 1$, res e ; (d) $z = 0$, res 1; $z = -1$, res -1 ;
- (e) $z = i$, res $\frac{1}{2}i$; $z = -i$, res $-\frac{1}{2}i$; (f) $z = 0$, res $-\frac{1}{2}$; $z = 2$, res $\frac{3}{2}$; (g) $z = 0$, res $\frac{1}{2}$;
- (h) $z = -2$, res 12; (i) $z = i$, res $-(1+i)$; $z = 0$, res $1+i$;

Empowering People. Improving Business.

BI Norwegian Business School is one of Europe's largest business schools welcoming more than 20,000 students. Our programmes provide a stimulating and multi-cultural learning environment with an international outlook ultimately providing students with professional skills to meet the increasing needs of businesses.

BI offers four different two-year, full-time Master of Science (MSc) programmes that are taught entirely in English and have been designed to provide professional skills to meet the increasing need of businesses. The MSc programmes provide a stimulating and multi-cultural learning environment to give you the best platform to launch into your career.

- MSc in Business
- MSc in Financial Economics
- MSc in Strategic Marketing Management
- MSc in Leadership and Organisational Psychology

BI NORWEGIAN BUSINESS SCHOOL

EFMD **EQUIS ACCREDITED**

www.bi.edu/master



Exercises 7

36 (a) $2\pi i$; (b) $-4\pi i$; (c) $2\pi e i$; (d) 0; (e) 0; (f) $2\pi i$; (g) πi ; (h) $24\pi i$; (i) 0; (j) only one pole inside, so $2\pi i$.

37 $\frac{\pi}{65}(9-7i)$.

38 (a) 0; (b) $2\pi i$; (c) $-8\pi i$; (d) $-6\pi i$.

39 (a) πi ; (b) πi ; (c) $6\pi i$.

40 (a) $\pi/6$; (b) $\pi/6$

(c) $-\pi/5$; (d) $\pi/2e$

(e) $\frac{\pi}{2}e^{-a}$; (f) $-\frac{\pi}{e}\sin 2$

(g) $\frac{1}{6}\pi(e^{-1}-e^{-2})$; (h) $\frac{1}{2}\pi e^{-2}$

(i) $\frac{1}{2}\pi i(e-e^{-1})e^{-\alpha}$

42 $\frac{2+3z^3}{(z-1)(9+z^2)} = 3 + \frac{3}{z} + \dots$ as $|z| \rightarrow \infty$.

43 (a) $\frac{1}{2}\pi$; (b) $\pi/20$; (c) $\frac{\pi}{\sqrt{k^2-1}}$, $k > 1$.

44 $\frac{2\pi i}{(s-1)!} \left(\frac{2\pi i}{\Gamma(s)} \right)$.

Exercises 8

45 $\frac{1}{k^2} [(1+iak)e^{-ika} - 1]$.

46 $\frac{2}{k^3} (a^2k^2 - 2) \sin(ka) + \frac{4a}{k^2} \cos(ka)$.

47 $\pi e^{-|k|a}$ (and calculate for $k > 0, k < 0$ separately).

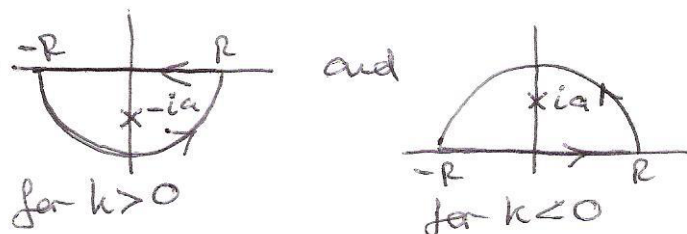

48 Transform is $\frac{a-ik}{a^2+k^2}$.

49 (a) $\frac{1}{2a} e^{-ax}$; (b) $-\frac{i}{2z} e^{-iax}$. (These valid for $x > 0$, using the upper semi-circular region; for $x < 0$ repeat in the lower -half-plane, or simply note that $f(-x) = f(x)$.)

Part II

The integral theorems of
complex analysis with applications to the evaluation of real integrals

Need help with your dissertation?

Get in-depth feedback & advice from experts in your topic area. Find out what you can do to improve the quality of your dissertation!

Get Help Now



Go to www.helpmyassignment.co.uk for more info



List of Integrals

This is a list of the integrals and associated calculations that are discussed in this Notebook.

Integral of $f(z) = 2z - iz^2$ along $z = \gamma(t) = t^2 + it$, from $t = 0$ to $t = 1$

$\oint_C f(z) dz$ for $f(z)$ is: (a) z^2 ; (b) $1/(z-2)$; (c) z^{-1} 111

$\int_C \frac{1}{z(z+3)} dz$ 114

$\int_C \frac{z+e^z}{1+z} dz$ 116

Given $f(z) = z^2$ on $C: z = re^{i\theta}$, $0 \leq \theta \leq 2\pi$, find $f(z)$ in interior of C 118

$\int_C \frac{z^2 - e^{z^2}}{z(z^2 - 1)(z + 3)} dz$ where C is $|z| = 2$ 123

$f(z) = \frac{1}{1+z^2}$ satisfies $|zf(z)| \leq K(R) \rightarrow 0$ on $|z| = R \rightarrow \infty$, and identify $K(R)$ 126

$f(z) = \frac{1}{1+z}$ satisfies $|f(z)| \leq K(R) \rightarrow 0$ on $|z| = R \rightarrow \infty$, and identify $K(R)$ 128

$\int_0^\infty \frac{x^2}{1+x^4} dx$ 129

$\int_{-\infty}^\infty \frac{dx}{(1+x^2)^3}$ 131

$\int_{-\infty}^\infty \frac{\cos(kx)}{(x+a)^2 + b^2} dx$ 132

$\int_{-\infty}^\infty \frac{x \sin x}{x^2 + 4} dx$ 134

Show that $\int_{-1}^2 \frac{dx}{x^{1/3}}$ exists.....	137
$\int_{-\infty}^{\infty} \frac{\sin x}{x} dx$	140
$\int_{-\infty}^{\infty} \frac{\sin x}{x(1+x^2)} dx$	143
$\int_0^{\infty} \frac{\ln x}{x^2+a^2} dx$	145
$\int_0^{\infty} \frac{x^{-k}}{1+x} dx$ with $0 < k < 1$	147
$\int_{-\infty}^{\infty} \frac{e^{\alpha x}}{1+e^x} dx$	150
$\int_0^{\infty} \cos(x^2) dx$	153
$\int_0^{2\pi} \frac{d\theta}{1+k \sin \theta}$ where $0 < k < 1$	157
$\int_0^{2\pi} \frac{\cos 2\theta}{\left(1-\frac{4}{5} \cos \theta\right)^2} d\theta$	158

Preface

This text gives an overview of the main integral theorems that are an essential element of complex analysis. This first appeared as a volume in the 'Notebook series' available to students in the School of Mathematics & Statistics at Newcastle University. The material has been provided here as an adjunct to Part I, where the main integral theorems are rehearsed and then applied to a number of more sophisticated and involved examples. The hope is that what we present here will help the reader to gain a broader experience of these mathematical ideas. The aim is to go beyond the simple and routine methods, techniques and applications.

We first provide proofs of the three main integral theorems, which cover some of the ground discussed in Part I, and then we describe various applications to the evaluation of real integrals, developed through a number of carefully worked examples. A small number of exercises, with answers, are also offered.



Brain power

By 2020, wind could provide one-tenth of our planet's electricity needs. Already today, SKF's innovative know-how is crucial to running a large proportion of the world's wind turbines.

Up to 25 % of the generating costs relate to maintenance. These can be reduced dramatically thanks to our systems for on-line condition monitoring and automatic lubrication. We help make it more economical to create cleaner, cheaper energy out of thin air.

By sharing our experience, expertise, and creativity, industries can boost performance beyond expectations. Therefore we need the best employees who can meet this challenge!

The Power of Knowledge Engineering

Plug into The Power of Knowledge Engineering.
Visit us at www.skf.com/knowledge

SKF

Introduction

Complex analysis, and particularly the theory associated with the integral theorems, is an altogether amazing and beautiful branch of mathematics that comfortably straddles both pure and applied mathematics. It provides the opportunity to analyse and present in a very formal way, as well as to develop a powerful tool in mathematical methods. The integral theorems take a staggeringly simple form, which seems to run counter to all the experience gained by students familiar with conventional integration methods. The consequence is that the results are very straightforward to use, even though they describe deep and far-reaching ideas. In this Notebook, we shall present, and prove, the three fundamental integral theorems: Cauchy's Integral Theorem and Integral Formula, and the Residue Theorem. These results are then used to evaluate various types of improper integrals (using direct methods, indented contours and regions with branch cuts) as well as integrals of functions that are periodic on $[0, 2\pi]$. As part of the essential background, we need to define carefully what we mean by the integral of complex-valued functions along curves in the complex plane; this is where we start.

1.1 Complex integration

We consider the differentiable function of a complex variable (i.e. an *analytic* function)

$$f(z) = f(x + iy) = u(x, y) + iv(x, y),$$

for which therefore the *Cauchy-Riemann relations* hold:

$$\frac{\partial u}{\partial x} = \frac{\partial v}{\partial y} \quad \text{and} \quad \frac{\partial u}{\partial y} = -\frac{\partial v}{\partial x}.$$

The aim is to define what it means to integrate $f(z)$ along a curve in the complex plane, but first we consider a simplified version of the essential problem, namely, $f(t) = u(t) + iv(t)$, where t is a suitable parameter. Thus we form, for $t \in [a, b]$,

$$\int_a^b f(t) dt = \int_a^b [u(t) + iv(t)] dt$$

$$= \int_a^b u(t) dt + i \int_a^b v(t) dt,$$

by invoking the linearity of the integral operator (and noting that 'i' is a constant independent of t).

Now suppose that, given $f(z)$, and a curve, C , described by $z = \gamma(t)$, $a \leq t \leq b$, we wish to integrate f along the curve i.e. form a line integral in the complex plane. We define this by using the familiar rule for the change of variable:

$$\int_C f(z) dz = \int_a^b f[\gamma(t)] \frac{d\gamma}{dt} dt.$$

The curves, C , that we use may be simple, open curves i.e. they are not closed and do not intersect, or – more usually – they will be *Jordan curves* i.e. simple, closed curves.

Example 1

Evaluate the integral of $f(z) = 2z - iz^2$ along the curve $z = \gamma(t) = t^2 + it$, from $t = 0$ to $t = 1$.

We have

$$\begin{aligned} f(z) &= f(x + iy) = 2(x + iy) - i(x^2 - y^2 + 2ixy) \\ &= 2x + 2xy + i(y^2 - x^2 + 2y), \end{aligned}$$

and $z = x(t) + iy(t) = \gamma(t) = t^2 + it$ i.e. $x(t) = t^2$ and $y(t) = t$ on the curve. Thus

$$\begin{aligned} \int_C f(z) dz &= \int_0^1 \left[2t^2(1+t) + i(t^2 - t^4 + 2t) \right] (2t + i) dt \\ &= \int_0^1 \left[4t^3(1+t) - (t^2 - t^4 + 2t) + i2t^2(1+t) + i2t(t^2 - t^4 + 2t) \right] dt \\ &= \left[t^4 + t^5 - \frac{1}{3}t^3 - t^2 + i\left(2t^3 + t^4 - \frac{1}{3}t^6\right) \right]_0^1 = \frac{2}{3} + i\frac{8}{3}. \end{aligned}$$

Comment: we observe that $\int f(z) dz = \int (2z - iz^2) dz = z^2 - \frac{1}{3}iz^3 + C$ and so the value of the integral from $z = 0$ (i.e. $t = 0$) to $z = 1 + i$ (i.e. $t = 1$) becomes

$$\left[z^2 - \frac{1}{3}iz^3 \right]_0^{1+i} = (1+i)^2 - \frac{1}{3}i(1+i)^3 = 2i - \frac{1}{3}i(-2 + 2i) = \frac{2}{3} + i\frac{8}{3}.$$

This recovers the previous result because, in this example, the function $f(z) = 2z - iz^2$ is an analytic function and so $\int f(z) dz$ has its conventional meaning.

We return to the original complex integral, and treat it as in Example 1, but now in general:

$$\begin{aligned}
 I &= \int_C f(z) dz = \int_C [u(x, y) + iv(x, y)] dz \\
 &= \int_{t_0}^{t_1} \{u[x(t), y(t)] + iv[x(t), y(t)]\} \gamma'(t) dt
 \end{aligned}$$

on the curve $z = \gamma(t)$, $t_0 \leq t \leq t_1$. Further, let us write explicitly $\gamma(t) = x(t) + iy(t)$, then

$$I = \int_{t_0}^{t_1} \{u[x(t), y(t)] + iv[x(t), y(t)]\} [x'(t) + iy'(t)] dt.$$

Finally, this can be recast as line integrals in x and y :

$$\begin{aligned}
 I &= \int_{t_0}^{t_1} \{u[x(t), y(t)]x'(t) - v[x(t), y(t)]y'(t)\} dt \\
 &\quad + i \int_{t_0}^{t_1} \{u[x(t), y(t)]y'(t) + v[x(t), y(t)]x'(t)\} dt \\
 &= \int_C [u(x, y) dx - v(x, y) dy] + i \int_C [v(x, y) dx + u(x, y) dy].
 \end{aligned}$$

This representation of the integral along a curve in the complex plane is the starting point for the integral theorems.

Exercises 1

- Evaluate the integral of the function $f(z) = z^3 - z^2 + i(z - 2)$ along the curve $z = \gamma(t) = 1 - t + i(t + t^2)$ from $t = 0$ to $t = 1$.
- Confirm, by direct integration of $\int f(z) dz$ followed by evaluation, your answer obtained in Q.1.
- Repeat Q.1 for the function $f(z) = \bar{z}$ (the conjugate of z) from $z = 0$ to $z = 1 + i$ along the curves: (a) $z = t + it$, $0 \leq t \leq 1$; (b) $z = t^2 - it^3$, $0 \geq t \geq -1$. (You should find that the answers are different: $f = \bar{z}$ is not an analytic function of z .)

2 The integral theorems

The three theorems all involve Jordan curves (so simple closed curves, sometimes called contours), but for three different types of function. The first case is the integral of a function that is analytic inside and on the Jordan curve; in the second, the function takes the form $f(z)/(z - z_0)$ where $f(z)$ satisfies the conditions of the first case and $z = z_0$ is a point inside the Jordan curve. The third – and arguably the most powerful result – is essentially a generalisation of the preceding one, to a finite number of singular points (usually poles) inside the contour. The first (the Cauchy Integral Theorem) can be proved by a direct application of Green's theorem, so we provide a brief reminder of this.

2.1 Green's theorem

Let us be given a Jordan curve, labelled Γ , which is mapped counter-clockwise; the region interior to Γ is labelled R . Further, we are given two functions, $u(x, y)$ and $v(x, y)$, which possess continuous first partial derivatives in R and on Γ . Although we can work separately with u or v , it is usual to combine the pair – particularly in the light of the complex-valued integral that we obtained in §1.1. The theorem is then expressed as

$$\oint_{\Gamma} [u(x, y) dx + v(x, y) dy] = \iint_R \left(\frac{\partial v}{\partial x} - \frac{\partial u}{\partial y} \right) dx dy,$$

which can be interpreted as a two-dimensional version of Gauss' (divergence) theorem. This is obtained by taking the divergence of the vector function $(v, -u)$ and, of course, restricting the geometry to the 2D plane (but remember that Green's theorem predates Gauss!). The circle on the line integral is used to denote a simple, closed contour, normally mapped counter-clockwise.

What do you want to do?

No matter what you want out of your future career, an employer with a broad range of operations in a load of countries will always be the ticket. Working within the Volvo Group means more than 100,000 friends and colleagues in more than 185 countries all over the world. We offer graduates great career opportunities – check out the Career section at our web site www.volvogroup.com. We look forward to getting to know you!

VOLVO
AB Volvo (publ)
www.volvogroup.com

VOLVO TRUCKS | RENAULT TRUCKS | MACK TRUCKS | VOLVO BUSES | VOLVO CONSTRUCTION EQUIPMENT | VOLVO PENTA | VOLVO AERO | VOLVO IT
VOLVO FINANCIAL SERVICES | VOLVO 3P | VOLVO POWERTRAIN | VOLVO PARTS | VOLVO TECHNOLOGY | VOLVO LOGISTICS | BUSINESS AREA ASA



2.2 Cauchy's integral theorem

We shall provide a proof – the classical one – of this theorem. The function $f(z)$ is necessarily an analytic function in the region R , and on the Jordan curve, C , that bounds this region. (It is common practice to label curves in the complex plane as C , whereas curves in the real plane are labelled Γ .) Furthermore, we shall make the additional assumption that $f'(z)$ is continuous in R and on C ; we shall comment on this second requirement later. We write

$$f(z) = f(x + iy) = u(x, y) + iv(x, y)$$

and then

$$\oint_C f(z) dz = \oint_C [u(x, y) dx - v(x, y) dy] + i \oint_C [v(x, y) dx + u(x, y) dy];$$

see §1.1. The two real line integrals that we have now generated are rewritten using Green's theorem (all the conditions for which are satisfied):

$$\oint_C [u(x, y) dx - v(x, y) dy] = \iint_R \left(-\frac{\partial v}{\partial x} - \frac{\partial u}{\partial y} \right) dx dy$$

and

$$\oint_C [v(x, y) dx + u(x, y) dy] = \iint_R \left(\frac{\partial u}{\partial x} - \frac{\partial v}{\partial y} \right) dx dy.$$

But $f(z)$ is an analytic function, so the Cauchy-Riemann relations hold i.e. $u_x = v_y$ and $u_y = -v_x$ throughout R (using subscripts to denote partial derivatives); so the two double integrals above are zero, and hence

$$\oint_C f(z) dz = 0,$$

which is *Cauchy's Integral Theorem* (1825).

Example 2

The contour C is a circle of radius 1, centre at the origin, mapped counter-clockwise; evaluate, where possible, $\oint_C f(z) dz$, given that $f(z)$ is: (a) z^2 ; (b) $1/(z-2)$; (c) z^{-1} .

a) The function $f(z) = z^2$ is analytic everywhere in the complex plane, so immediately $\oint_C z^2 dz = 0$.

b) The function $f(z) = \frac{1}{z-2}$ is not analytic at $z = 2$, but is analytic everywhere else, i.e. it is analytic for all $0 \leq |z| \leq 1$, so again $\oint_C dz/(z-2) = 0$.

(c) Now the function $f(z) = z^{-1}$ is not analytic at $z = 0$, which is inside C , so we are not able to use Cauchy's integral theorem; we cannot (yet) find the value of the integral.

Cauchy's integral theorem requires only that $f(z)$ be analytic (and $f'(z)$ continuous for our proof, but see later) inside and on the Jordan curve, C : any valid Jordan curve will therefore suffice. This implies that, given any particular C , we may *deform* C into any other Jordan curve, provided that inside and on the new curve, $f(z)$ satisfies the same conditions as just mentioned; on all such curves, we have $\oint_C f(z) dz = 0$. Thus, even if $f(z)$ is not analytic at points in the complex plane, any contour that avoids them will still produce the zero value for the integral; we sketch some examples below.

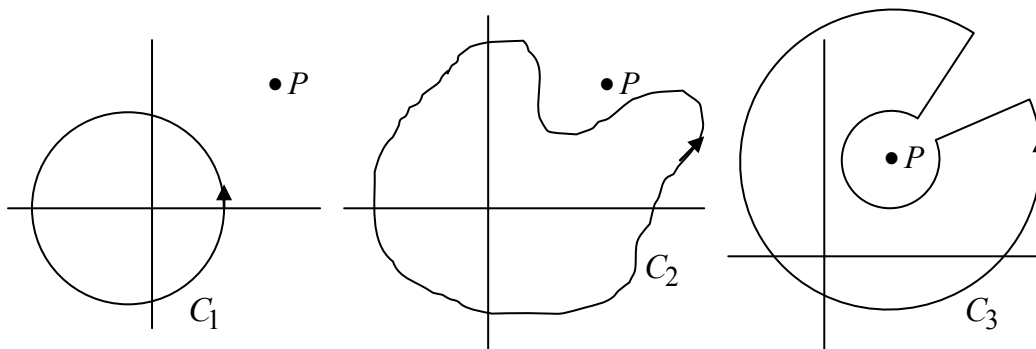

The function in this example is not analytic (i.e. it is singular) at the point P in the plane; Cauchy's integral theorem applies on all three contours (C_1, C_2, C_3).

Indeed, we may deform the contour in a more precise fashion, as shown below:

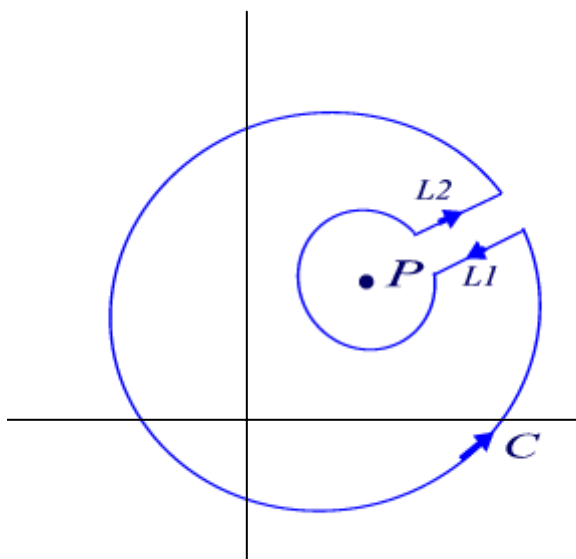

where the two straight-line segments, $L1$ and $L2$, are parallel and equal in length. We now close the gap between these two lines, and ensure that the inner contour so produced encircles the singularity at P ; when the lines coincide, the line integrals on each cancel. This is simply because the integral (which exists – the function is analytic on C) in one direction is minus the value of the integral in the other. In the limit, we obtain:

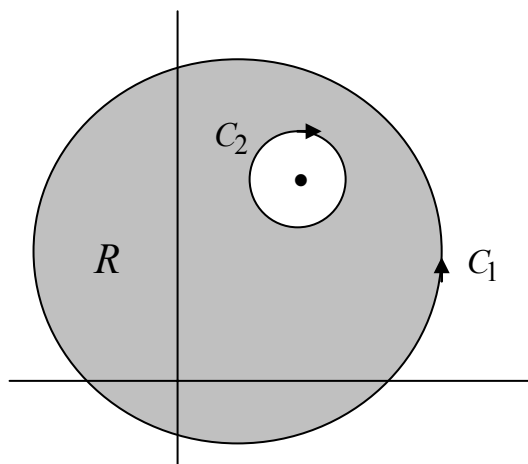

and we still have $\oint_C f(z) dz = 0$ where $C = C_1 + C_2$, and the region, R , is that between C_1 and C_2 . The totality of the contour, and its enclosed region, is conveniently interpreted this way: as the contour is mapped out, so the region (R) is always on the left. This is a fundamentally important choice of deformed contour, as we shall see in §2.2.

Example 3

The contour C is a circle of radius 2, mapped counter-clockwise, together with the circle of radius 1, mapped clockwise, both centred at the origin; the region R is the annulus between them. Evaluate $\oint_C f(z) dz$ where $f(z) = 1/z(z + 3)$.

The advertisement features a background image of a person running on a path during a sunrise or sunset. In the top left, the GaiTEYE logo is displayed with the tagline "Challenge the way we run". Below the logo, the text reads "EXPERIENCE THE POWER OF FULL ENGAGEMENT...". A horizontal dotted line separates this from the next section, which says "RUN FASTER. RUN LONGER.. RUN EASIER...". In the bottom right, a yellow button contains the text "READ MORE & PRE-ORDER TODAY" and the website "WWW.GAITEYE.COM", with a hand cursor icon pointing to it.



The function $f(z)$ is singular – it has simple poles – only at $z = 0$ and $z = -3$; it is analytic everywhere else. These two points sit outside the annulus $1 \leq |z| \leq 2$, so Cauchy’s integral theorem gives $\oint_C f(z) dz = 0$.

We conclude this introductory section by making two general observations. Our proof of Cauchy’s integral theorem requires that $f(z)$ is analytic and that $f'(z)$ is continuous on and inside C . However, E.J.-B. Goursat (1858-1936) proved in 1900 that Cauchy’s integral theorem is valid even if the condition on $f'(z)$ is relaxed: it is sufficient that $f(z)$ be continuous, and that $f'(z)$ exists, inside and on C .

The second point relates to a converse of Cauchy’s integral theorem. If $f(z)$ is continuous throughout a domain, D , in the complex plane, and if $\oint_C f(z) dz = 0$ on every Jordan curve, C , in D , then $f(z)$ is analytic in D . This is known as *Morera’s theorem*; G. Morera (1856-1907), an Italian mathematician, who proved this result in 1889.

2.3 Cauchy’s integral formula

We are given a function, $f(z)$, analytic inside and on the Jordan curve, C , mapped counter-clockwise, and a point $z = z_0$ interior to C ; we consider the integral

$$\oint_C \frac{f(z)}{z - z_0} dz.$$

The contour that we use for the purposes of evaluation is C as just defined, plus a circle C_0 , mapped clockwise, of radius ε with its centre at $z = z_0$. The circle must sit wholly within C , which is always possible for z_0 an interior point and a sufficiently small (but non-zero) radius; the configuration is sketched in the figure below.

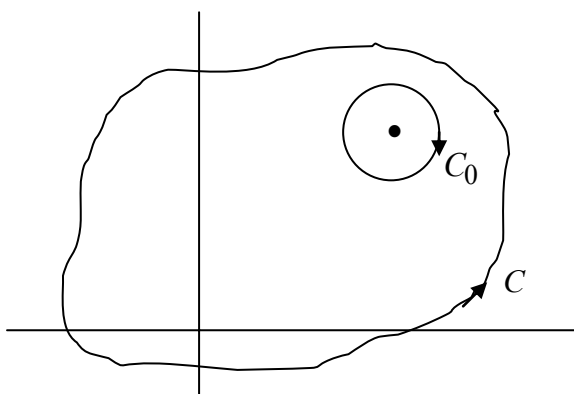

Now by Cauchy’s integral theorem we have

$$\oint_{C+C_0} \frac{f(z)}{z - z_0} dz = 0$$

or

$$\oint_C \frac{f(z)}{z - z_0} dz = - \oint_{C_0} \frac{f(z)}{z - z_0} dz,$$

where the circle, C_0 , is mapped clockwise; we describe the circle using the parametric form $z = z_0 + \varepsilon e^{i\theta}$ for $2\pi \geq \theta \geq 0$. Thus we may write

$$\oint_{C_0} \frac{f(z)}{z - z_0} dz = \int_{2\pi}^0 \frac{f(z_0 + \varepsilon e^{i\theta})}{\varepsilon e^{i\theta}} \varepsilon i e^{i\theta} d\theta$$

$$= i \int_{2\pi}^0 f(z_0 + \varepsilon e^{i\theta}) d\theta.$$

This integral can be evaluated – and any evaluation will suffice – by allowing $\varepsilon \rightarrow 0$ (which is allowed because $f(z)$ is a continuous function), which gives

$$i \int_{2\pi}^0 f(z_0) d\theta = -2\pi i f(z_0)$$

and so

$$\oint_C \frac{f(z)}{z - z_0} dz = 2\pi i f(z_0),$$

which is *Cauchy's Integral Formula* (1831).

Example 4

Evaluate $\oint_C \frac{z + e^z}{1 + z} dz$, where C is the circle $|z| = 2$, mapped counter-clockwise.

This is evaluated by a direct application of Cauchy's integral formula: $z = -1$ is inside C , so we have

$$\oint_C \frac{f(z)}{z - z_0} dz = 2\pi i f(z_0),$$

An illuminating and intriguing interpretation of Cauchy's integral formula is made more obvious when we write it as

$$f(z) = \frac{1}{2\pi i} \oint_C \frac{f(\zeta)}{\zeta - z} d\zeta.$$

That is, given an analytic function defined on C , $f(z)$ is then known at every point *inside* C . This result has no counterpart in the theory of real functions.

Example 5

Given that $f(z) = z^2$ on the contour C , defined by $z = re^{i\theta}$, $0 \leq \theta \leq 2\pi$, determine $f(z)$ throughout the interior of C .

We form $f(z) = \frac{1}{2\pi i} \oint_C \frac{\zeta^2}{\zeta - z} d\zeta$, where z is any interior point; thus we obtain on $\zeta = re^{i\theta}$:

$$f(z) = \frac{1}{2\pi i} \int_0^{2\pi} \frac{(re^{i\theta})^2}{re^{i\theta} - z} rie^{i\theta} d\theta,$$

and we note that $z \neq re^{i\theta}$ for every θ (because z is interior to the circle). It is convenient to rewrite the integrand as

$$\frac{r^3 e^{3i\theta}}{re^{i\theta} - z} = r^2 e^{2i\theta} + rze^{i\theta} + \frac{z^2 re^{i\theta}}{re^{i\theta} - z},$$

and then we have

$$\begin{aligned} & \int_0^{2\pi} i \left(r^2 e^{2i\theta} + rze^{i\theta} + \frac{z^2 re^{i\theta}}{re^{i\theta} - z} \right) d\theta \\ &= \left[\frac{1}{2} r^2 e^{2i\theta} + rze^{i\theta} + z^2 \log(re^{i\theta} - z) \right]_0^{2\pi} \\ &= z^2 \left[\log(re^{i\theta} - z) \right]_0^{2\pi} = 2\pi iz^2, \end{aligned}$$

This e-book
is made with
SetaPDF

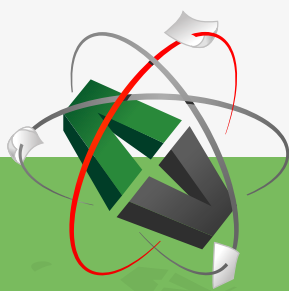

PDF components for PHP developers

www.setasign.com



by virtue of the jump in value of the logarithmic function across its branch cut. Thus $f(z) = z^2$ on C and throughout the interior of C .

Before we turn to the most powerful and useful of these integral theorems, we need one more result, which puts into a clearer perspective the identity

$$\oint_{C_0} \frac{dz}{z - z_0} = 2\pi i,$$

where C_0 is a circle (or, indeed, any contour in this result) that encircles $z = z_0$. We now consider the evaluation of

$$I_n = \oint_{C_0} (z - z_0)^n dz$$

where $n = 0, 1, \pm 2, \pm 3, \dots$ and C_0 is the circle $z = z_0 + re^{i\theta}$, $0 \leq \theta \leq 2\pi$; note that the case (omitted here) of $n = -1$ is evaluated by Cauchy's integral formula. Thus we have

$$\begin{aligned} I_n &= \int_0^{2\pi} r^n e^{in\theta} r i e^{i\theta} d\theta = i r^{1+n} \left[\frac{e^{i(1+n)\theta}}{i(1+n)} \right]_0^{2\pi} \\ &= \frac{r^{1+n}}{1+n} [e^{i2\pi(1+n)} - 1] = 0, \end{aligned}$$

for every $n \neq -1$. Indeed, this makes clear just how special $n = -1$ is: in this case, treating the problem as a conventional integral yields a logarithmic term, which requires a branch cut (and a consequent jump in value) in order to evaluate it. In summary, we have

$$I_n = \oint_{C_0} (z - z_0)^n dz = \begin{cases} 2\pi i & \text{for } n = -1 \\ 0 & \text{for all other } ns, \end{cases}$$

where C_0 is a circle, centre z_0 , mapped counter-clockwise.

2.4 The (Cauchy) residue theorem

The function, $f(z)$, is now assumed to have a finite number of singular points inside the Jordan curve C ; at each point, valid within an appropriate annulus about the point ($z = z_0$, say), it is assumed that $f(z)$ can be expressed as a *Laurent series* i.e.

$$f(z) = \sum_{n=0}^{\infty} a_n (z - z_0)^n + \sum_{n=1}^{\infty} \frac{b_n}{(z - z_0)^n}.$$

This always exists for a function that is analytic except at a finite number of discrete singular points, each annulus being centred around each point, and not enclosing another one. A function that possesses a Laurent series about a point at which the terms in b_n , i.e. the negative powers, do not terminate is said to have an *essential singularity* at this point. A function that has Laurent series that terminates in the b_n s for every singularity has only *poles* (of a given order) and such a function is normally called a *meromorphic* function. That is, a meromorphic function has no essential singularities, but it does have poles; cf. analytic, which implies no singularities of any sort. [‘Meromorphic’ comes from Greek (μερος and μορφος), and means, literally, ‘part of the form/appearance’, which is to be compared with ‘holomorphic’ – which is sometimes used in place of ‘analytic’ – meaning ‘whole of the appearance.’]

The new theorem relates to the value of $\oint_C f(z) dz$, where C is as described above; this situation is represented in the figure below.

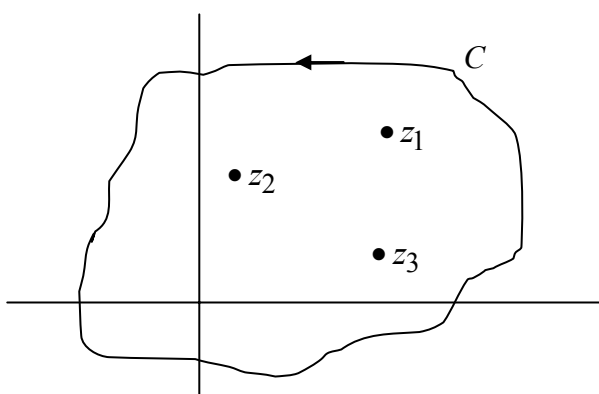

In this example, the contour C encloses three singular points.

To proceed, we use Cauchy’s integral theorem on a deformed contour; this is constructed as in §2.2 so we deform around z_1 (say), enclose this by an almost-complete circle, and then close the circle. The contour otherwise is deformed around all the other singular points, ensuring that they remain outside the contour. This is represented in the figure below:

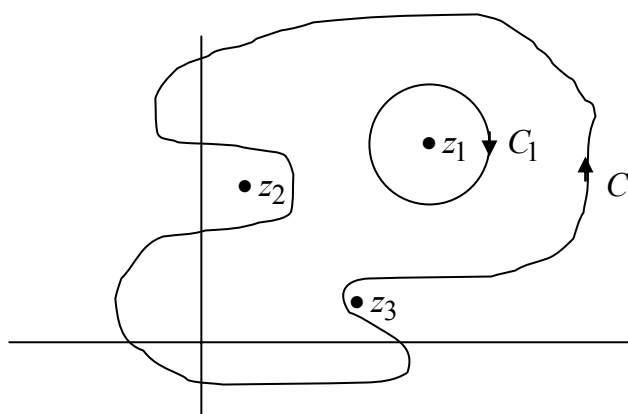

The contour C'_1 encloses only z_1 , which is itself enclosed by a circle, C_1 .

Cauchy's integral theorem then gives

$$\oint_{C_1'} f(z) dz + \oint_{C_1} f(z) dz = 0,$$

where, as we have seen before, C_1' is mapped counter-clockwise, but C_1 is mapped clockwise. Now choosing C_1 to be inside the annulus around $z = z_1$, inside which the Laurent expansion exists, enables us to write

$$\begin{aligned} \oint_{C_1} f(z) dz &= \oint_{C_1} \left\{ \sum_{n=0}^{\infty} a_n (z-z_1)^n + \sum_{n=1}^{\infty} b_n (z-z_1)^{-n} \right\} dz \\ &= -2\pi i b_1, \end{aligned}$$

and zero if the term in $(z-z_1)^{-1}$ is absent, for then $b_1 = 0$; b_1 is called the *residue* of $f(z)$ at $z = z_1$. Thus we have the evaluation

$$\oint_{C_1'} f(z) dz = 2\pi i b_1.$$

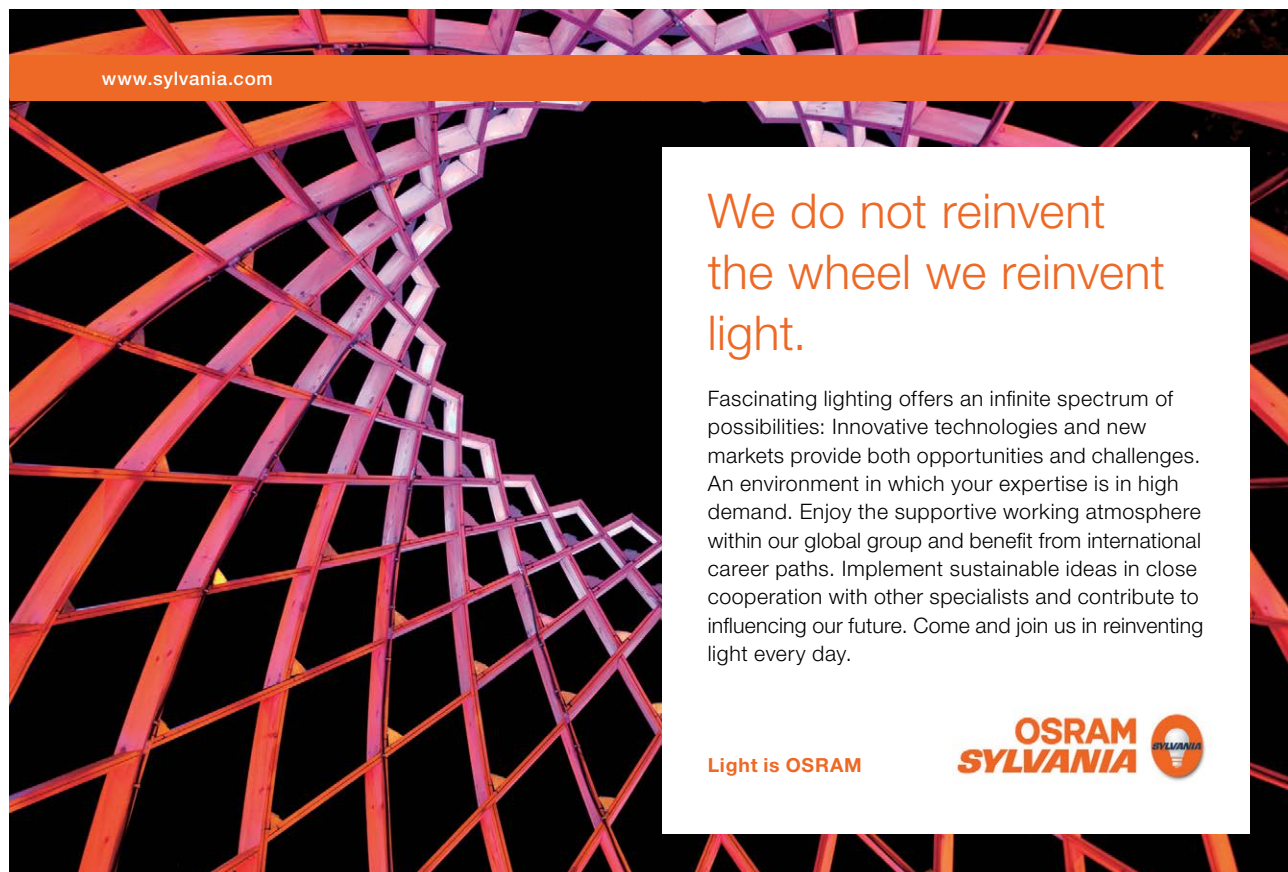

www.sylvania.com

We do not reinvent
the wheel we reinvent
light.

Fascinating lighting offers an infinite spectrum of possibilities: Innovative technologies and new markets provide both opportunities and challenges. An environment in which your expertise is in high demand. Enjoy the supportive working atmosphere within our global group and benefit from international career paths. Implement sustainable ideas in close cooperation with other specialists and contribute to influencing our future. Come and join us in reinventing light every day.

Light is OSRAM

OSRAM
SYLVANIA

Let us relabel the residue, so that it corresponds to the coefficient b_1 at $z = z_1$, by writing it as b_{11} ; the corresponding residue at $z = z_n$ is then b_{1n} . This process of forming circles around each singular point is continued by next encircling z_2 , and then z_3 , and so on, each one contributing a term $2\pi i \times \text{residue}$. Combining all the contributions from the singular points inside C gives us

$$\oint_C f(z) dz = 2\pi i \left(\sum_{n=1}^N b_{1n} \right)$$

for N singular points inside C ; this is the *Residue Theorem*, sometimes called the *Cauchy Residue Theorem* (1846).

It is clear that the residue theorem subsumes both Cauchy’s integral theorem and integral formula. For, on the one hand, if the function is analytic – so no singular points anywhere – then all the b_n s will be zero for the Laurent expansions about every point; hence the value of the contour integral will be zero: Cauchy’s integral theorem. On the other hand, if the function to be integrated takes the form $f(z) = g(z)/(z - z_0)$, where $g(z)$ is analytic inside and on the contour and $z = z_0$ is an interior point, then there is a one singular point inside C with a residue $g(z_0)$, which recovers Cauchy’s integral formula.

Example 6

Evaluate $\oint_C \frac{z^2 - e^{z^2}}{z(z^2 - 1)(z + 3)} dz$ where C is the Jordan curve $|z| = 2$, mapped counter-clockwise.

The function $f(z) = \frac{z^2 - e^{z^2}}{z(z - 1)(z + 1)(z + 3)}$ has (simple) poles at $z = 0, \pm 1$ inside C ;

the pole at $z = -3$ is outside C and therefore does not contribute. In the neighbourhood of each pole we have

at $z = 0$: $f(z) = \dots \frac{1}{3z} \dots$ and so the residue here is $\frac{1}{3}$;

at $z = 1$: $f(z) = \dots \frac{1 - e}{8(z - 1)} \dots$ and so the residue is $\frac{1 - e}{8}$;

at $z = -1$: $f(z) = \dots \frac{1 - e}{4(z + 1)} \dots$ and here the residue is $\frac{1 - e}{4}$.

(These results can be obtained by observation, since no formal expansion is required to determine the relevant terms.) The residue theorem then gives

$$\oint_C \frac{z^2 - e^{z^2}}{z(z^2 - 1)(z + 3)} dz = 2\pi i \left(\frac{1}{3} + \frac{1 - e}{8} + \frac{1 - e}{4} \right) = \left(\frac{17}{12} - \frac{3}{4}e \right) \pi i.$$

Exercises 2

1. Evaluate $\oint_C \frac{\sin z}{z+2} dz$ where C , mapped counter-clockwise, is the circle: (a) $|z| = 1$; (b) $|z| = 3$.

2. Evaluate $\oint_C \frac{ze^z - \cos z}{z(z^2 - 4)} dz$ where C , mapped counter-clockwise, is the circle: (a) $|z| = 1$; (b) $|z| = r > 2$.



Discover the truth at www.deloitte.ca/careers

Deloitte.

© Deloitte & Touche LLP and affiliated entities.



Click on the ad to read more

3 Evaluation of simple, improper real integrals

The first simple and direct application of complex integration to the evaluation of real integrals is to improper integrals of the type

$$\int_{-\infty}^{\infty} f(x) dx \quad \text{or} \quad \int_0^{\infty} f(x) dx \quad \text{if } f(x) \text{ is an even function.}$$

In order to evaluate these integrals, we consider

$$\oint_C f(z) dz$$

for a suitable choice of the contour, C . Since we eventually require the integral along the real line, this (initially in the form $-R$ to R) must be included as part of C . The most convenient way to accomplish this (but not exclusively so, as we shall see later) is to use a contour which is the boundary of a semi-circular region of radius R , normally taken to be in the upper half-plane:

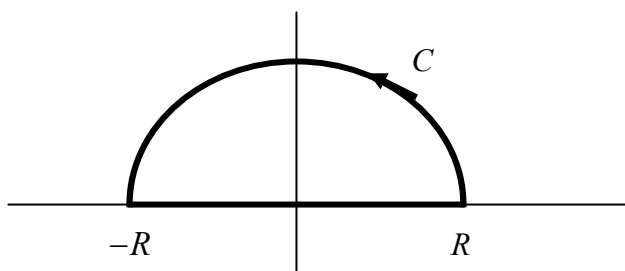

The integral in the complex plane can therefore be written

$$\oint_C f(z) dz = \int_{-R}^R f(z) dz + \int_{sc} f(z) dz$$

where 'sc' denotes the integral along the semi-circular arc; further, on the real line we have $z = x$, so we may write

$$\oint_C f(z) dz = \int_{-R}^R f(x) dx + \int_{sc} f(z) dz.$$

The procedure is to evaluate $\int_{sc} f(z) dz$, using the residue theorem with the radius of the arc sufficiently large to enclose all the singular points in the upper half-plane, to estimate the integral along the arc and then to let $R \rightarrow \infty$. In practice, the useful results occur only if $\int_{sc} f(z) dz \rightarrow 0$ as $R \rightarrow \infty$; we now investigate this important aspect of the problem.

3.1 Estimating integrals on semi-circular arcs

We shall examine two cases: $zf(z) \rightarrow 0$ uniformly as $R \rightarrow \infty$, and $e^{ikz} f(z)$ ($k > 0$ and real) with $f(z) \rightarrow 0$ uniformly as $R \rightarrow \infty$, both on the semi-circular arc. By 'uniformly' we mean the following: if $|g(z)| \leq K(R)$, where $R = |z|$, and if $K(R) \rightarrow 0$ as $R \rightarrow \infty$, we say that $g(z) \rightarrow 0$ uniformly as $R \rightarrow \infty$.

(a) Type 1

We are given that $|zf(z)| \leq K(R)$ with $K(R) \rightarrow 0$ as $R \rightarrow \infty$; we now consider the integral $\int_{sc} f(z) dz$ and construct an estimate for it:

$$\left| \int_{sc} f(z) dz \right| \leq \int_{sc} |f(z)| |dz| = \int_0^\pi |f(z)| R d\theta.$$

But $|zf(z)| = |z||f(z)| = R|f(z)| \leq K(R)$, and so we obtain

$$R \int_0^\pi |f(z)| d\theta \leq K \int_0^\pi d\theta = K\pi \rightarrow 0 \text{ as } R \rightarrow \infty;$$

thus $\int_{sc} f(z) dz \rightarrow 0$ as $R \rightarrow \infty$.

Example 7

Show that $f(z) = \frac{1}{1+z^2}$ satisfies $|zf(z)| \leq K(R) \rightarrow 0$ on the semi-circular arc, as $R \rightarrow \infty$, and identify $K(R)$.

We have $zf(z) = \frac{z}{1+z^2}$, and on the semi-circular arc $|z| = R$; but by the triangle inequality, we have

$$|1+z^2| + 1 \geq |z^2| = R^2$$

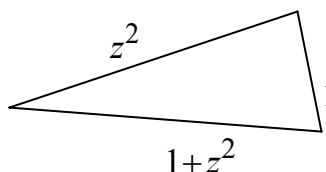

and so $\left| \frac{z}{1+z^2} \right| = \frac{|z|}{|1+z^2|} \leq \frac{R}{R^2-1} = K(R) \rightarrow 0$ as $R \rightarrow \infty$.

(b) Type 2

This time we are given $|f(z)| \leq K(R) \rightarrow 0$ on the semi-circular arc, as $R \rightarrow \infty$; the integral under consideration is $\int_{sc} e^{ikz} f(z) dz$ where k is real and positive.

(If k is complex-valued, then the imaginary part can be subsumed into the definition of $f(z)$, but the condition on the new $f(z)$ must be unchanged.) We proceed in a similar fashion to that adopted for type 1:

$$\left| \int_{sc} e^{ikz} f(z) dz \right| \leq \int_{sc} |e^{ikz} f(z)| dz = \int_0^\pi |e^{ikz} f(z)| R d\theta,$$

and note that

$$|e^{ikz} f(z)| = |e^{ik(x+iy)} f(z)| = e^{-ky} |f(z)| \leq e^{-ky} K(R).$$

SIMPLY CLEVER

ŠKODA



Do you like cars? Would you like to be a part of a successful brand? We will appreciate and reward both your enthusiasm and talent. Send us your CV. You will be surprised where it can take you.

Send us your CV on www.employerforlife.com



Click on the ad to read more

Thus we may write

$$\left| \int_{sc} e^{ikz} f(z) dz \right| \leq RK \int_0^\pi e^{-ky} d\theta,$$

and on the semi-circular arc $y = R \sin \theta$, so we now require an estimate for

$$\int_0^\pi e^{-kR \sin \theta} d\theta = 2 \int_0^{\pi/2} e^{-kR \sin \theta} d\theta.$$

But a standard result is that $\frac{\sin \theta}{\theta} \geq \frac{2}{\pi}$ or $\sin \theta \geq \frac{2}{\pi} \theta$, so that we have

$$e^{-kR \sin \theta} \leq e^{-2kR\theta/\pi},$$

and hence

$$\int_0^{\pi/2} e^{-kR \sin \theta} d\theta \leq \int_0^{\pi/2} e^{-2kR\theta/\pi} d\theta = -\frac{\pi}{2kR} \left[e^{-2kR\theta/\pi} \right]_0^{\pi/2} = \frac{\pi}{2kR} (1 - e^{-kR}).$$

When we combine these results, we obtain

$$\left| \int_{sc} e^{ikz} f(z) dz \right| \leq 2KR \frac{\pi}{2kR} (1 - e^{-kR}) = \frac{\pi}{k} (1 - e^{-kR}) K \rightarrow 0 \text{ as } R \rightarrow \infty,$$

and so we have proved that $\int_{sc} e^{ikz} f(z) dz \rightarrow 0$ as $R \rightarrow \infty$. (This is sometimes referred to as *Jordan's lemma*.)

Example 7

Show that $f(z) = \frac{1}{1+z}$ satisfies $|f(z)| \leq K(R) \rightarrow 0$ on the semicircular arc, as $R \rightarrow \infty$, and identify $K(R)$.

This is very straightforward, based directly on the triangle inequality:

$$|1+z| + 1 \geq |z| = R \text{ so } \left| \frac{1}{1+z} \right| = \frac{1}{|1+z|} \leq \frac{1}{R-1} = K(R) \rightarrow 0 \text{ as } R \rightarrow \infty.$$

3.2 Real integrals of type 1

We explain the essential ingredients of the method by evaluating an improper integral that is not elementary, although it does take a fairly simple form:

$$\int_0^{\infty} \frac{x^2}{1+x^4} dx.$$

The complex integral that we consider is

$$\oint_C f(z) dz \text{ with } f(z) = \frac{z^2}{1+z^4};$$

this function has a denominator $z^4 + 1 = (z^2 + i)(z^2 - i)$ which has zeros in the upper half-plane at $z = \frac{1}{\sqrt{2}}(1+i), \frac{1}{\sqrt{2}}(-1+i)$. Thus we have, for $R > 1$, the following picture

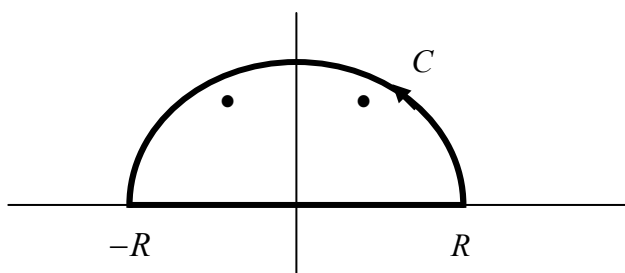

The semi-circular region has two poles inside it, at $z = \frac{1}{\sqrt{2}}(\pm 1 + i)$.

and then it is convenient to write

$$\frac{z^2}{1+z^4} = \frac{z^2}{\left[z - \frac{1}{\sqrt{2}}(1+i) \right] \left[z - \frac{1}{\sqrt{2}}(1-i) \right] \left[z - \frac{1}{\sqrt{2}}(-1+i) \right] \left[z - \frac{1}{\sqrt{2}}(-1-i) \right]}.$$

The residues at the two (simple) poles inside C are now easily obtained:

$$\text{at } z = \frac{1}{\sqrt{2}}(1+i): \frac{\frac{1}{2}(1+i)^2}{(i\sqrt{2})(-\sqrt{2}+i\sqrt{2})(i\sqrt{2})} = \frac{1}{i4\sqrt{2}}(1+i) = \frac{1}{4\sqrt{2}}(1-i);$$

$$\text{at } z = \frac{1}{\sqrt{2}}(-1+i): \frac{\frac{1}{2}(-1+i)^2}{(-\sqrt{2})(-\sqrt{2}+i\sqrt{2})(i\sqrt{2})} = -\frac{1}{i4\sqrt{2}}(-1+i) = -\frac{1}{4\sqrt{2}}(1+i).$$

We may express the contour integral as

$$\oint_C \frac{z^2}{1+z^4} dz = \int_{-R}^R \frac{x^2}{1+x^4} dx + \int_{sc} \frac{z^2}{1+z^4} dz,$$

and $|1+z^4| \geq R^4 - 1$ so that $\left| z \frac{z^2}{1+z^4} \right| \leq \frac{R^3}{R^4 - 1} \rightarrow 0$ as $R \rightarrow \infty$:

the condition for the type 1 integral is satisfied. We also have, by an application of the residue theorem,

$$\oint_C \frac{z^2}{1+z^4} dz = 2\pi i \left[\frac{1}{4\sqrt{2}} (1-i-1-i) \right] = \frac{\pi}{\sqrt{2}}.$$

Thus, letting $R \rightarrow \infty$, we obtain

$$\int_{-\infty}^{\infty} \frac{x^2}{1+x^4} dx = \frac{\pi}{\sqrt{2}}$$

and then, because the integrand is an even function, we finally have the evaluation

I joined MITAS because
I wanted **real responsibility**

The Graduate Programme
for Engineers and Geoscientists
www.discovermitas.com



Month 16

I was a construction supervisor in the North Sea advising and helping foremen solve problems

Real work
International opportunities
Three work placements





$$\int_0^{\infty} \frac{x^2}{1+x^4} dx = \frac{\pi}{2\sqrt{2}}.$$

We now try one further example of this type.

Example 8

Evaluate $\int_{-\infty}^{\infty} \frac{dx}{(1+x^2)^3}$.

We consider the integral (with C the boundary of the standard semi-circular region)

$$\oint_C \frac{dz}{(1+z^2)^3} = \int_{-R}^R \frac{dx}{(1+x^2)^3} + \int_{sc} \frac{dz}{(1+z^2)^3};$$

we see that $|1+z^2| \geq R^2 - 1$ and so, $\left| \frac{z}{(1+z^2)^3} \right| \leq \frac{R}{(R^2-1)^3} \rightarrow 0$ as $R \rightarrow \infty$.

We also have $z^2 + 1 = (z+i)(z-i)$, which gives a pole (of order 3) at $z = i$ in the upper half-plane; thus we write, with $\zeta = z - i$,

$$\begin{aligned} \frac{1}{(z+i)^3(z-i)^3} &= \frac{1}{\zeta^3(2i+\zeta)^3} = \frac{(2i)^{-3}}{\zeta^3} \left(1 - \frac{1}{2}i\zeta\right)^{-3} \\ &= \frac{i}{8} \frac{1}{\zeta^3} \left(1 + \frac{3}{2}i\zeta - \frac{3}{2}\zeta^2 + \dots\right), \end{aligned}$$

and thus the residue at $z = i$ is $-\frac{3}{32}i$. Hence, taking $R \rightarrow \infty$, we obtain

$$\int_{-\infty}^{\infty} \frac{dx}{(1+x^2)^3} = 2\pi i \left(-\frac{3i}{32}\right) = \frac{3}{8}\pi.$$

We are now in a position to consider some type 2 integrals.

3.3 Real integrals of type 2

This type of improper integral is nicely represented by this problem: find the value of

$$\int_{-\infty}^{\infty} \frac{\cos(kx)}{(x+a)^2 + b^2} dx,$$

where k, a and b are real constants, and we take $k > 0, b > 0$. Although we could use $\cos(kz)$ (provided that the relevant conditions hold on the semi-circular arc), it is far neater and more straightforward to replace $\cos(kx)$ by e^{ikx} (and eventually take the real part). Thus we consider

$$\oint_C \frac{e^{ikz}}{(z+a)^2 + b^2} dz = \int_{-R}^R \frac{e^{ikx}}{(x+a)^2 + b^2} dx + \int_{sc} \frac{e^{ikz}}{(z+a)^2 + b^2} dz,$$

and on the semi-circular arc

$$|(z+a)^2 + b^2| = |z^2 + 2az + a^2 + b^2| \geq |z|^2 - 2a|z| - a^2 - b^2 = R^2 - 2aR - a^2 - b^2;$$

i.e.
$$|f(z)| = \left| \frac{1}{(z+a)^2 + b^2} \right| \leq \frac{1}{R^2 - 2aR - a^2 - b^2} \rightarrow 0 \text{ as } R \rightarrow \infty,$$

and the type 2 conditions are satisfied.

We have that $(z+a)^2 + b^2 = (z+a+ib)(z+a-ib)$ which is zero in the upper half-plane at $z = -a+ib$, so we have, for $R > \sqrt{a^2 + b^2}$,

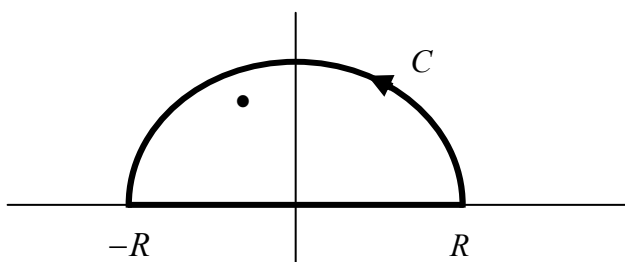

The semi-circular contour has one pole inside, at $z = -a + ib$.

and then the residue at $z = -a + ib$ is
$$\frac{e^{ik(-a+ib)}}{-a+ib+a+ib} = -\frac{i}{2b} e^{-kb-iak}.$$

Hence we find

$$\oint_C \frac{e^{ikz}}{(z+a)^2 + b^2} dz = 2\pi i \left(-\frac{i}{2b} e^{-kb-iak} \right) = \frac{\pi}{b} e^{-kb-iak}$$

and so, letting $R \rightarrow \infty$, we obtain

$$\int_{-\infty}^{\infty} \frac{e^{ikx}}{(x+a)^2 + b^2} dx = \frac{\pi}{b} e^{-kb-iak};$$

when we then take the real part of this equation, we obtain

$$\int_{-\infty}^{\infty} \frac{\cos(kx)}{(x+a)^2 + b^2} dx = \frac{\pi}{b} e^{-kb} \cos(ak).$$

In passing, we can note that in this example – and this is typical of problems interpreted by introducing e^{ikz} – we also obtain the integral

$$\int_{-\infty}^{\infty} \frac{\sin(kx)}{(x+a)^2 + b^2} dx = -\frac{\pi}{b} e^{-kb} \sin(ak),$$

so two integrals are evaluated for the price of one calculation.

ie business school

#1 EUROPEAN BUSINESS SCHOOL
FINANCIAL TIMES 2013

#gobeyond

MASTER IN MANAGEMENT

Because achieving your dreams is your greatest challenge. IE Business School's Master in Management taught in English, Spanish or bilingually, trains young high performance professionals at the beginning of their career through an innovative and stimulating program that will help them reach their full potential.

- Choose your area of specialization.
- Customize your master through the different options offered.
- Global Immersion Weeks in locations such as London, Silicon Valley or Shanghai.

Because you change, we change with you.

www.ie.edu/master-management | mim.admissions@ie.edu |

Let us now tackle another example of this type.

Example 9

Evaluate $\int_{-\infty}^{\infty} \frac{x \sin x}{x^2 + 4} dx$.

To evaluate this, we consider the integral

$$\oint_C \frac{ze^{iz}}{z^2 + 4} dz = \int_{-R}^R \frac{xe^{ix}}{x^2 + 4} dx + \int_{sc} \frac{ze^{iz}}{z^2 + 4} dz,$$

and note that $|z^2 + 4| \geq |z^2| - 4 = R^2 - 4$ so that $\left| \frac{z}{z^2 + 4} \right| \leq \frac{R}{R^2 - 4} \rightarrow 0$ as $R \rightarrow \infty$.

But we have $z^2 + 4 = (z + 2i)(z - 2i)$ which is zero in the upper half-plane at $z = 2i$; we have the residue at $z = 2i$ as

$$\frac{2ie^{-2}}{4i} = \frac{1}{2}e^{-2}.$$

Thus
$$\oint_C \frac{ze^{iz}}{z^2 + 4} dz = 2\pi i \left(\frac{1}{2} e^{-2} \right) = i\pi e^{-2},$$

and then, with $R \rightarrow \infty$, we get

$$\int_{-\infty}^{\infty} \frac{xe^{ix}}{x^2 + 4} dx = i\pi e^{-2};$$

on taking the imaginary part, this produces the required evaluation:

$$\int_{-\infty}^{\infty} \frac{x \sin x}{x^2 + 4} dx = \pi e^{-2}.$$

Comment: In this example, we see that the real part gives

$$\int_{-\infty}^{\infty} \frac{x \cos x}{x^2 + 4} dx = 0$$

which is no surprise because the integrand is an odd function. Thus, although we can use this method to find

$$\int_0^{\infty} \frac{x \sin x}{x^2 + 4} dx \quad (= \frac{1}{2} \pi e^{-2})$$

we are unable to find $\int_0^{\infty} \frac{x \cos x}{x^2 + 4} dx$ (even though this is expected to exist and be non-zero).

Exercises 3

Evaluate these real integrals:

(a) $\int_{-\infty}^{\infty} \frac{dx}{(1+x^2)(x^2+4)}$; (b) $\int_0^{\infty} \frac{dx}{(1+x^2)^2}$; (c) $\int_{-\infty}^{\infty} \frac{\cos x}{x^4+4} dx$.



STUDY AT A TOP RANKED INTERNATIONAL BUSINESS SCHOOL

Reach your full potential at the Stockholm School of Economics, in one of the most innovative cities in the world. The School is ranked by the Financial Times as the number one business school in the Nordic and Baltic countries.

Visit us at www.hhs.se





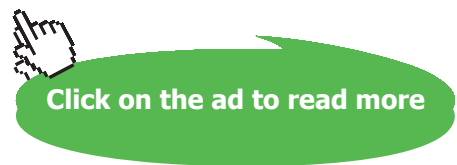

4 Indented contours, contours with branch cuts and other special contours

The examples described in the previous chapter have enabled us to introduce the basic principles that apply to the evaluation of real integrals, using these techniques, although all the problems have involved a semi-circular region in the complex plane. However, any contour could be chosen and the consequences explored, which may lead to a suitable method of evaluation – but it may not! In this chapter we will present a few examples that require different choices of contour, some which turn out to be an adjustment of the classical semi-circular one, but others are very different. Indeed, we shall find that, in order to evaluate certain integrals, we may use the semi-circle, but with indentations. On other occasions, the integrand itself can be defined only by the inclusion of branch cuts, and this must be accommodated by the chosen contour. Finally we shall show that, for other evaluations, some very special contours must be used. However, we typically encounter some technical problems (associated with the definition and existence of integrals, even though the original real integral is well behaved); this aspect needs to be addressed first.

4.1 Cauchy principal value

In order to tackle integrals such as

$$\int_{-\infty}^{\infty} \frac{\sin x}{x} dx$$

we shall discuss two difficulties that stem from the consideration of the integral of e^{iz}/z . For example, it is immediately clear that $\sin x/x$ is integrable in the neighbourhood of $x = 0$ (for $\sin x/x \rightarrow 1$ as $x \rightarrow 0$), whereas e^{iz}/z does not exist at $z = 0$. The original real integral does exist, although confirming this by examining the behaviour at infinity is not straightforward; thus the simple estimate $|\sin x| \leq 1$ leads to the integral of $1/x$, yielding $\ln|x|$ which diverges as $|x| \rightarrow \infty$.

The familiar choice of a semi-circular region does work for this example, using the integrand e^{iz}/z , which satisfies the requirements of a type 2 integral (§3.3) at infinity. However, we must define what we mean by the integral of a function that possesses the property of this one near $z = 0$ (which, we must expect, should not be critical to the evaluation of the real integral because this does exist). We first address the problem of developing a suitable definition, and then we will see how we can incorporate this within a formulation of an integral in the complex plane.

The situation that we must clarify is best described by reminding ourselves of the definition of an improper integral, where the failure to be ‘proper’ is because the integrand is not defined at a point in the range of integration. A simple example is the integral

$$\int_0^x y^{-k} dy, \text{ for } 0 < k < 1 \text{ and } x > 0,$$

where y^{-k} does not exist at $y = 0$. The value of this integral (if it exists) is defined by

$$\lim_{\varepsilon \rightarrow 0^+} \left(\int_{\varepsilon}^x y^{-k} dy \right);$$

this gives

$$\lim_{\varepsilon \rightarrow 0^+} \left(\left[\frac{y^{1-k}}{1-k} \right]_{\varepsilon}^x \right) = \lim_{\varepsilon \rightarrow 0^+} \left(\frac{1}{1-k} [x^{1-k} - \varepsilon^{1-k}] \right) = \left(\frac{1}{1-k} \right) x^{1-k}$$

because $\varepsilon^{1-k} \rightarrow 0$ with $0 < k < 1$: the integral exists. Let us now suppose that we require the integral of $f(x)$, for $x \in [a, b]$, where $f(x_0)$, $a < x_0 < b$, is undefined; the integral exists if

$$\lim_{\varepsilon \rightarrow 0^+} \left(\int_a^{x_0 - \varepsilon} f(x) dx \right) + \lim_{\delta \rightarrow 0^+} \left(\int_{x_0 + \delta}^b f(x) dx \right)$$

is finite. The use of two parameters is essential here, making clear that the processes $\varepsilon \rightarrow 0^+$ and $\delta \rightarrow 0^+$ are independent.

Example 10

Show that the real integral $\int_{-1}^2 \frac{dx}{x^{1/3}}$ exists (where, of course, it is necessary that all values of x^k , for suitable k , are taken to be real).

The integral is defined as

$$\begin{aligned} & \lim_{\varepsilon \rightarrow 0^+} \left(\int_{-1}^{-\varepsilon} x^{-1/3} dx \right) + \lim_{\delta \rightarrow 0^+} \left(\int_{\delta}^2 x^{-1/3} dx \right) \\ &= \lim_{\varepsilon \rightarrow 0^+} \left(\left[\frac{3}{2} x^{2/3} \right]_{-1}^{-\varepsilon} \right) + \lim_{\delta \rightarrow 0^+} \left(\left[\frac{3}{2} x^{2/3} \right]_{\delta}^2 \right) \\ &= \lim_{\varepsilon \rightarrow 0^+} \left(\frac{3}{2} (-\varepsilon)^{2/3} - \frac{3}{2} (-1)^{2/3} \right) + \lim_{\delta \rightarrow 0^+} \left(\frac{3}{2} 2^{2/3} - \frac{3}{2} \delta^{2/3} \right) \\ &= \frac{3}{2} (2^{2/3} - 1). \end{aligned}$$

Comment: We should note that the corresponding argument for $\int_{-1}^2 \frac{dx}{\sqrt{x}}$ fails because the integrand, and hence the integral, are not real for $x < 0$. In this case we can allow only the one-sided limit

$$\lim_{\varepsilon \rightarrow 0^+} \left(\int_{\varepsilon}^2 \frac{dx}{\sqrt{x}} \right).$$



#1
in eco-friendly attitude

STUDY AT LINKÖPING UNIVERSITY, SWEDEN
RANKED AMONG TOP 50 UNIVERSITIES UNDER 50

Interested in Strategy and Management in International Organisations? Kick-start your career with a master's degree from Linköping University, Sweden.

→ **Click here!**

 **Linköping University**



Let us now apply this same approach to the integral

$$\int_{-1}^2 \frac{dx}{x},$$

so we consider

$$\begin{aligned} \lim_{\varepsilon \rightarrow 0^+} \left(\int_{-1}^{-\varepsilon} \frac{dx}{x} \right) + \lim_{\delta \rightarrow 0^+} \left(\int_{\delta}^2 \frac{dx}{x} \right) \\ = \lim_{\varepsilon \rightarrow 0^+} \left([\ln|x|]_{-1}^{-\varepsilon} \right) + \lim_{\delta \rightarrow 0^+} \left([\ln|x|]_{\delta}^2 \right) \\ = \lim_{\varepsilon \rightarrow 0^+} (\ln \varepsilon - \ln 1) + \lim_{\delta \rightarrow 0^+} (\ln 2 - \ln \delta). \end{aligned}$$

However, $\ln \varepsilon$ and $\ln \delta$ increase indefinitely in size as $\varepsilon \rightarrow 0^+$ and $\delta \rightarrow 0^+$, respectively: the integral does not exist, according to the familiar definition (and this result should be no surprise). But there is something rather special about this example; if we allowed $\varepsilon = \delta$, then we obtain

$$\lim_{\varepsilon \rightarrow 0^+} (\ln \varepsilon - \ln 1 + \ln 2 - \ln \varepsilon) = \ln 2,$$

and the integral exists! Nevertheless, we should be aware that even this manoeuvre does not always work; consider

$$\int_{-1}^2 \frac{dx}{x^2}$$

which we write as

$$\lim_{\varepsilon \rightarrow 0^+} \left(\int_{-1}^{-\varepsilon} \frac{dx}{x^2} + \int_{\varepsilon}^2 \frac{dx}{x^2} \right) = \lim_{\varepsilon \rightarrow 0^+} \left(\left[-\frac{1}{x} \right]_{-1}^{-\varepsilon} + \left[-\frac{1}{x} \right]_{\varepsilon}^2 \right) = \lim_{\varepsilon \rightarrow 0^+} \left(\frac{1}{\varepsilon} - \frac{3}{2} + \frac{1}{\varepsilon} \right);$$

this does not exist – the two terms in ε do *not* cancel.

The *Cauchy Principal Value*, when it exists, is defined by

$$\lim_{\varepsilon \rightarrow 0^+} \left(\int_a^{x_0 - \varepsilon} f(x) dx + \int_{x_0 + \varepsilon}^b f(x) dx \right)$$

and this value is usually represented by a bar through the integral sign, $\overline{\int} f(x) dx$, or by writing

$$PV \int_a^b f(x) dx.$$

Of course, a function may possess more than one point where it does not exist, so the principal-value definition must be applied to each one. We also record that the definition can be extended to an integral that is improper because the limits extend to infinity. So the integral

$$\int_0^{\infty} x dx \text{ clearly does not exist,}$$

and neither does $\int_{-\infty}^{\infty} x dx$; on the other hand, the Cauchy principal value of this latter integral is defined as

$$\lim_{R \rightarrow \infty} \left(\int_{-R}^R x dx \right) = \lim_{R \rightarrow \infty} \left(\left[\frac{1}{2} x^2 \right]_{-R}^R \right) = \lim_{R \rightarrow \infty} \left(\frac{1}{2} R^2 - \frac{1}{2} R^2 \right) = 0,$$

which *does* exist.

4.2 The indented contour

We return to the real integral that we introduced above, and use this as a vehicle to describe and explain how contours are indented. Thus in order to evaluate

$$\int_{-\infty}^{\infty} \frac{\sin x}{x} dx \text{ we consider } \oint_C \frac{e^{iz}}{z} dz,$$

which satisfies the type 2 conditions at infinity, but is undefined at $z = 0$. Thus we take as the contour, C , a semi-circular arc together with the diameter along the real axis indented by a (small) semi-circular arc that allows us to avoid $z = 0$, as shown in the figure below.

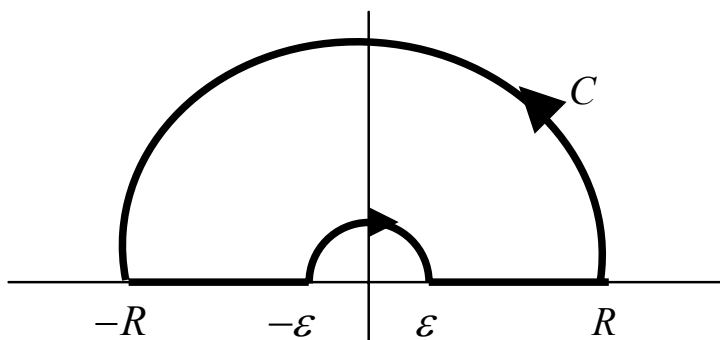

The contour comprising two semi-circular arcs (radii R and ϵ) and an almost-complete diameter connecting them.

According to Cauchy's integral theorem, we have

$$\oint_C \frac{e^{iz}}{z} dz = 0,$$

because the only singularity of e^{iz}/z is a simple pole at $z = 0$ which lies outside the contour. But we may write the integral on C as

“I studied English for 16 years but...
...I finally learned to speak it in just six lessons”

Jane, Chinese architect

ENGLISH OUT THERE

Click to hear me talking before and after my unique course download



$$\int_{-R}^{-\varepsilon} \frac{e^{ix}}{x} dx + \int_{\varepsilon}^R \frac{e^{ix}}{x} dx + \int_{SC\varepsilon} \frac{e^{iz}}{z} dz + \int_{sc} \frac{e^{iz}}{z} dz = 0,$$

where $SC\varepsilon$ labels the integral on the semi-circular arc of radius ε (mapped clockwise), and sc is our familiar label for the larger semi-circle. We know that

$$\int_{sc} \frac{e^{iz}}{z} dz \rightarrow 0 \text{ as } R \rightarrow \infty$$

(cf. Example 7), but we do not know the behaviour on $SC\varepsilon$ (although we might surmise that is it $-\frac{1}{2} \times 2\pi i \times \text{residue} = -\frac{1}{2} \times 2\pi i \times 1 = -i\pi$).

On the smaller semi-circular arc, we have $z = \varepsilon e^{i\theta}$, $\pi \geq \theta \geq 0$, so we obtain

$$\begin{aligned} \int_{SC\varepsilon} \frac{e^{iz}}{z} dz &= \int_{\pi}^0 \frac{\exp(i\varepsilon e^{i\theta})}{\varepsilon e^{i\theta}} \varepsilon i e^{i\theta} d\theta \\ &= i \int_{\pi}^0 \exp(i\varepsilon e^{i\theta}) d\theta \\ &\rightarrow i \int_{\pi}^0 d\theta = -i\pi \text{ as } \varepsilon \rightarrow 0; \end{aligned}$$

its value is indeed $-i\pi$! Thus we may write, once we have taken $\varepsilon \rightarrow 0$ and $R \rightarrow \infty$,

$$\int_{-\infty}^{\infty} \frac{e^{ix}}{x} dx = i\pi,$$

the principal value being necessary because we have taken $\varepsilon \rightarrow 0$ about $x = 0$. The imaginary part of this equation yields

$$\int_{-\infty}^{\infty} \frac{\sin x}{x} dx = \pi,$$

which we may write like this because the integral does exist in the conventional sense. On the other hand, when we take the real part, the principal-value notation must be retained to give

$$\oint_{-\infty}^{\infty} \frac{\cos x}{x} dx = 0;$$

this integral certainly does not exist in the conventional sense – it is not integrable at $x = 0$ – but it does in the PV sense.

Example 11

Evaluate $\int_{-\infty}^{\infty} \frac{\sin x}{x(1+x^2)} dx$.

We consider the integral $\oint_C \frac{e^{iz}}{z(1+z^2)} dz$, which requires an indented contour around $z = 0$, exactly as in the example above. However, we also have simple poles at $z = \pm i$, and we may note that, on the semi-circular arc of radius R :

$$\left| \frac{1}{z(1+z^2)} \right| \leq \frac{1}{R(R^2-1)} \rightarrow 0 \text{ as } R \rightarrow \infty.$$

The residue at $z = i$ is $e^{-1}/i \cdot 2i = -\frac{1}{2}e^{-1}$, and so we obtain

$$\oint_C \frac{e^{iz}}{z(1+z^2)} dz = 2\pi i \left(-\frac{1}{2}e^{-1}\right) = -i\pi e^{-1}.$$

However, the integral along C can be written as

$$\int_{-R}^{-\varepsilon} \frac{e^{ix}}{x(1+x^2)} dx + \int_{\varepsilon}^R \frac{e^{ix}}{x(1+x^2)} dx + \int_{sc\varepsilon} \frac{e^{iz}}{z(1+z^2)} dz + \int_{scR} \frac{e^{iz}}{z(1+z^2)} dz = -i\pi e^{-1},$$

where $\int_{scR} \frac{e^{iz}}{z(1+z^2)} dz \rightarrow 0$ as $R \rightarrow \infty$. On $z = \varepsilon e^{i\theta}$, $\pi \geq \theta \geq 0$, we obtain

$$\int_{\pi}^0 \frac{\exp(i\varepsilon e^{i\theta})}{\varepsilon e^{i\theta}(1+\varepsilon^2 e^{2i\theta})} i\varepsilon e^{i\theta} d\theta = i \int_{\pi}^0 \frac{\exp(i\varepsilon e^{i\theta})}{1+\varepsilon^2 e^{2i\theta}} d\theta \rightarrow -i\pi \text{ as } \varepsilon \rightarrow 0.$$

Thus, letting $R \rightarrow \infty$ and $\varepsilon \rightarrow 0$, we see that

$$\oint_{-\infty}^{\infty} \frac{e^{ix}}{x(1+x^2)} dx = i\pi - i\pi e^{-1},$$

and then the imaginary part yields

$$\int_{-\infty}^{\infty} \frac{\sin x}{x(1+x^2)} dx = \pi(1 - e^{-1}).$$

Comment: This same complex integral gives $\oint_{-\infty}^{\infty} \frac{\cos x}{x(1+x^2)} dx = 0$ (by taking the real part), although the integral $\int_{-\infty}^{\infty} \frac{\cos x}{x(1+x^2)} dx$ does not exist in the conventional sense.

4.3 Contours with branch cuts

The logarithmic function, $\log z$, is the function that is the most familiar one with a branch cut. It is usual to take the cut along the negative real axis, thereby defining the principal value as

Excellent Economics and Business programmes at:



university of
 groningen



“The perfect start of a successful, international career.”

CLICK HERE
to discover why both socially and academically the University of Groningen is one of the best places for a student to be

www.rug.nl/feb/education



A suitable interpretation is necessary for the evaluation of integrals such as

$$\int_0^{\infty} \frac{\ln x}{x^2 + a^2} dx,$$

where a is a positive, real constant, when treated as a corresponding integral in the complex plane. The natural way to attempt an evaluation is to replace $\ln x$ by $\log z$, and then by $\text{Log}z$ (to make it single valued), together with a suitable contour; so we consider

$$\oint_C \frac{\text{Log}z}{z^2 + a^2} dz.$$

The choice of C requires some care, when we note the existence of the branch cut necessary for $\text{Log}z$. We have a simple pole at $z = ia = ae^{i\pi/2}$ in the upper half-plane, and we anticipate that the integral along the semi-circular arc tends to zero as the radius increases, so we use the C shown below.

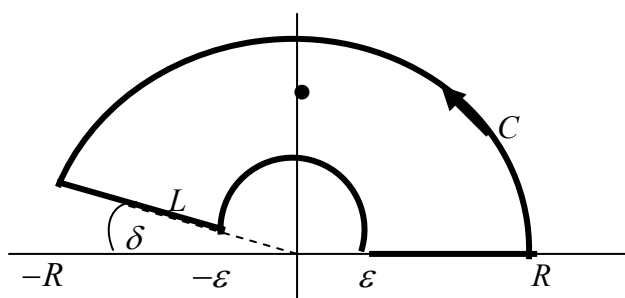

The two semi-circular arcs extend from $\theta = 0$ to $\theta = \pi - \delta$; the radii of the arcs are R and ϵ , and they are joined along $\theta = \pi - \delta$ by the straight line L . The branch cut is along the negative real axis.

First, we write

$$\frac{\text{Log}z}{z^2 + a^2} = \frac{\text{Log}z}{(z + ia)(z - ia)},$$

and then the residue at $z = ia$ becomes

$$\frac{\text{Log}(ia)}{2ia} = \frac{\text{Log}(ae^{i\pi/2})}{2ia} = -\frac{i}{2a}(\ln a + i\pi/2) = \frac{\pi}{4a} - i\frac{\ln a}{2a};$$

the residue theorem now gives

$$\oint_C \frac{\text{Log}z}{z^2 + a^2} dz = 2\pi i \left(\frac{\pi}{4a} - i \frac{\ln a}{2a} \right) = \frac{\pi}{a} \ln a + i \frac{\pi^2}{2a}.$$

The contour integral can be expressed as

$$\oint_C \frac{\text{Log}z}{z^2 + a^2} dz = \int_{\varepsilon}^R \frac{\ln x}{x^2 + a^2} dx + \int_{sc} \frac{\text{Log}z}{z^2 + a^2} dz + \int_L \frac{\text{Log}z}{z^2 + a^2} dz + \int_{sc\varepsilon} \frac{\text{Log}z}{z^2 + a^2} dz,$$

where sc and $sc\varepsilon$ denote, here, the almost-complete semi-circular arcs (see the figure above), and L is the line $z = re^{i(\pi-\delta)}$, $\varepsilon \leq r \leq R$. On the larger semi-circular arc we have

$$\left| \frac{z \text{Log}z}{z^2 + a^2} \right| \leq \frac{R |\text{Log}z|}{R^2 - a^2} = \frac{R \sqrt{(\ln R)^2 + \theta^2}}{R^2 - a^2} \rightarrow 0 \text{ as } R \rightarrow \infty,$$

(because $0 \leq \theta \leq \pi - \delta$) which therefore satisfies the type 1 condition. On the smaller semi-circular arc, we have

$$\int_{\pi}^0 \frac{\text{Log}(\varepsilon e^{i\theta})}{\varepsilon^2 e^{2i\theta} + a^2} \varepsilon i e^{i\theta} d\theta = i \varepsilon \int_{\pi}^0 \frac{(\ln \varepsilon + i\theta) e^{i\theta}}{a^2 + \varepsilon^2 e^{2i\theta}} d\theta \rightarrow 0 \text{ as } \varepsilon \rightarrow 0;$$

thus, with $R \rightarrow \infty$ and $\varepsilon \rightarrow 0$, we are left with

$$\oint_C \frac{\text{Log}z}{z^2 + a^2} dz = \int_0^{\infty} \frac{\ln x}{x^2 + a^2} dx + \int_{bc} \frac{\text{Log}z}{z^2 + a^2} dz \quad \left(= \frac{\pi}{a} \ln a + i \frac{\pi^2}{2a} \right).$$

But on the branch cut (bc) we have $z = re^{i\pi}$, $\infty > r \geq 0$, so we may write

$$\int_{bc} \frac{\text{Log}z}{z^2 + a^2} dz = \int_{\infty}^0 \frac{\ln r + i\pi}{r^2 + a^2} (-1) dr = \int_0^{\infty} \frac{\ln r}{r^2 + a^2} dr + i\pi \int_0^{\infty} \frac{dr}{r^2 + a^2},$$

and this latter integral is elementary: $\int_0^{\infty} \frac{dr}{r^2 + a^2} = \left[\frac{1}{a} \arctan(r/a) \right]_0^{\infty} = \frac{\pi}{2a}$.

Thus, finally, we have

$$\int_0^{\infty} \frac{\ln x}{x^2 + a^2} dx + \int_0^{\infty} \frac{\ln r}{r^2 + a^2} dr + i \frac{\pi^2}{2a} = 2 \int_0^{\infty} \frac{\ln x}{x^2 + a^2} dx + i \frac{\pi^2}{2a} = \frac{\pi}{a} \ln a + i \frac{\pi^2}{2a},$$

and so the required evaluation is

$$\int_0^{\infty} \frac{\ln x}{x^2 + a^2} dx = \frac{\pi}{2a} \ln a.$$

One – perhaps rather surprising – outcome of this calculation is the special case $a = 1$:

$$\int_0^{\infty} \frac{\ln x}{x^2 + 1} dx = 0,$$

and then an interpretation of this is $\int_0^1 \frac{\ln x}{x^2 + 1} dx = -\int_1^{\infty} \frac{\ln x}{x^2 + 1} dx$.

Another fairly common appearance of branch cuts (because it is directly associated with the logarithmic function) is in the evaluation of z^k for arbitrary k ; we will investigate this case in the next example.

Example 12

Evaluate $\int_0^{\infty} \frac{x^{-k}}{1+x} dx$ for real k with $0 < k < 1$. (This integral is related to the *Beta function*.)



In the past four years we have drilled

89,000 km

That's more than **twice** around the world.

Who are we?
We are the world's largest oilfield services company¹. Working globally—often in remote and challenging locations—we invent, design, engineer, and apply technology to help our customers find and produce oil and gas safely.

Who are we looking for?
Every year, we need thousands of graduates to begin dynamic careers in the following domains:

- Engineering, Research and Operations
- Geoscience and Petrotechnical
- Commercial and Business

What will you be?

 careers.slb.com

Schlumberger

¹Based on Fortune 500 ranking 2011. Copyright © 2015 Schlumberger. All rights reserved.



In order to evaluate this integral, we consider $\oint_C \frac{z^{-k}}{1+z} dz$, for a suitable choice of the contour C ; we must take the principal value of z^{-k} defined by

$$z^{-k} = \exp[-k(\ln r + i\theta)],$$

with the cut along $\theta = 0$ (because we have a pole at $z = -1$ i.e. on $\theta = \pi$), so we use $0 \leq \theta < 2\pi$. The contour we use is

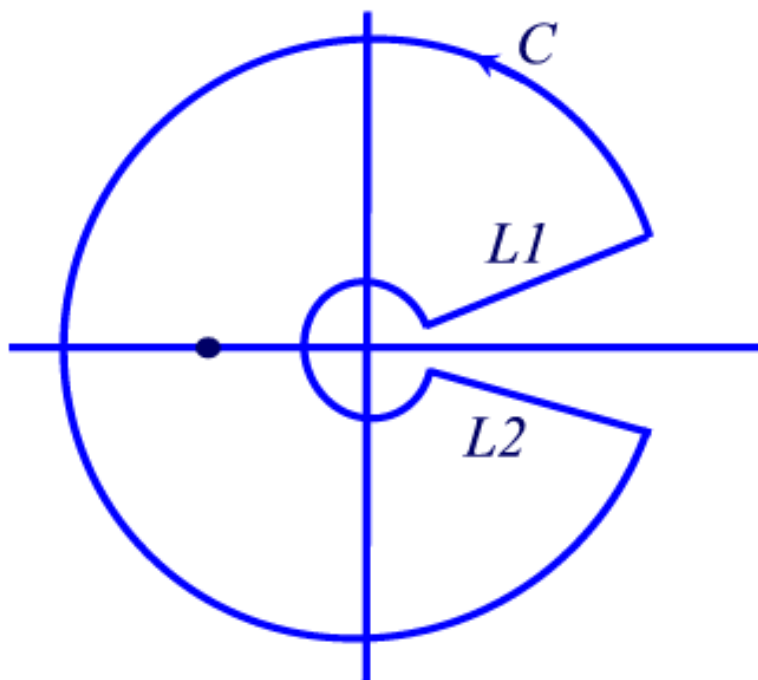

where the outer, almost-complete circle is of radius R and the corresponding inner one is of radius ϵ (for $0 < \epsilon < 1$); the two straight lines, $L1$ and $L2$, are $z = re^{\pm i\delta}$ for $\delta > 0$ and $\epsilon \leq r \leq R$. The singular point is at $z = e^{i\pi} = -1$, which lies between the two almost-complete circles. This type of curve is often called a *keyhole* contour. The residue at the (simple) pole is $\exp[-k(\ln 1 + i\pi)] = e^{-ik\pi}$, and then the residue theorem gives

$$\oint_C \frac{z^{-k}}{1+z} dz = 2\pi i e^{-ik\pi}.$$

But we may write

$$\oint_C \frac{z^{-k}}{1+z} dz = \int_{CR} \frac{z^{-k}}{1+z} dz + \int_{c\epsilon} \frac{z^{-k}}{1+z} dz + \int_{L1} \frac{z^{-k}}{1+z} dz + \int_{L2} \frac{z^{-k}}{1+z} dz,$$

where CR denotes the almost-complete circle of radius R (mapped counter-clockwise), and $c\epsilon$ is the corresponding inner circular arc (mapped clockwise). On CR we have

$$\left| \frac{z^{-k}}{1+z} \right| \leq \frac{R^{1-k}}{R-1} \rightarrow 0 \text{ as } R \rightarrow \infty,$$

and so

$$\int_{CR} \frac{z^{-k}}{1+z} dz \rightarrow 0 \text{ as } R \rightarrow \infty;$$

also, on $c\varepsilon$, where $z = \varepsilon e^{i\theta}$, $2\pi - \delta \geq \theta \geq \delta$, we may write this integral as

$$\int_{2\pi-\delta}^{\delta} \frac{\varepsilon^{-k} e^{-ik\theta}}{1+\varepsilon e^{i\theta}} \varepsilon i e^{i\theta} d\theta = i\varepsilon^{1-k} \int_{2\pi-\delta}^{\delta} \frac{e^{i(1-k)\theta}}{1+\varepsilon e^{i\theta}} d\theta \rightarrow 0 \text{ as } \varepsilon \rightarrow 0.$$

Finally, on $L1$ and $L2$ (and we note the directions along these lines), we have

$$\begin{aligned} & \int_{\varepsilon}^R \frac{r^{-k} e^{-ik\delta}}{1+re^{i\delta}} e^{i\delta} dr + \int_R^{\varepsilon} \frac{r^{-k} e^{-ik(2\pi-\delta)}}{1+re^{i(2\pi-\delta)}} e^{i(2\pi-\delta)} dr \\ &= e^{i(1-k)\delta} \int_{\varepsilon}^R \frac{r^{-k}}{1+re^{i\delta}} dr - e^{i(1-k)(2\pi-\delta)} \int_{\varepsilon}^R \frac{r^{-k}}{1+re^{i(2\pi-\delta)}} dr \\ &\rightarrow (1 - e^{-i2k\pi}) \int_{\varepsilon}^R \frac{r^{-k}}{1+r} dr \text{ as } \delta \rightarrow 0. \end{aligned}$$

Then, collecting all these results together, and taking $\delta \rightarrow 0$, $\varepsilon \rightarrow 0$ and $R \rightarrow \infty$, we obtain

$$\oint_C \frac{z^{-k}}{1+z} dz = (1 - e^{-i2k\pi}) \int_0^{\infty} \frac{x^{-k}}{1+x} dx = 2\pi i e^{-ik\pi}.$$

Thus

$$(e^{ik\pi} - e^{-ik\pi}) \int_0^{\infty} \frac{x^{-k}}{1+x} dx = 2\pi i,$$

and with $e^{ik\pi} - e^{-ik\pi} = 2i \sin(k\pi)$, the required value is

$$\int_0^{\infty} \frac{x^{-k}}{1+x} dx = \frac{\pi}{\sin(k\pi)} \quad (\text{for } 0 < k < 1).$$

4.4 Special contours

We conclude with two examples that require special choices for the contour. We have become rather familiar with the semi-circular contour, or some suitable refinement of it; indeed, it is by far the most common choice, but for some functions it is altogether inappropriate.

(a) A rectangular region

We consider the problem of evaluating

$$\int_{-\infty}^{\infty} \frac{e^{\alpha x}}{1+e^x} dx,$$

where α might be a complex constant, but such that $0 < \Re(\alpha) < 1$; it is clear that this condition on α is necessary in order to guarantee the existence of the integral. (Note the behaviour of the integrand as $x \rightarrow \pm\infty$.) We shall take the case of the real integral, so α will be real here. We introduce the integral

American online

LIGS University

is currently enrolling in the
Interactive Online **BBA, MBA, MSc,**
DBA and PhD programs:

- ▶ enroll **by September 30th, 2014** and
- ▶ **save up to 16%** on the tuition!
- ▶ pay in 10 installments / 2 years
- ▶ Interactive **Online education**
- ▶ visit www.ligsuniversity.com to find out more!

Note: LIGS University is not accredited by any nationally recognized accrediting agency listed by the US Secretary of Education. More info [here](#).





$$\oint_C \frac{e^{\alpha z}}{1+e^z} dz,$$

and observe that $1+e^z = 0$ for $z = i(1+2n)\pi$, for $n = 0, \pm 1, \pm 2, \dots$, so that a semi-circular contour which is extended to infinity will necessarily enclose an increasing number of poles. Thus we select a rectangle that encloses only one pole, at $z = i\pi$, and so we take C as the rectangle ($2R \times 2\pi$) shown in the figure below.

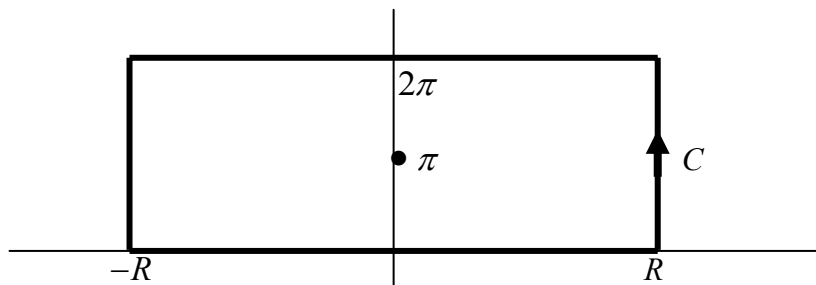

The only pole inside C is at $z = i\pi$, with the residue obtained by writing $z = i\pi + \zeta$:

$$\frac{e^{\alpha z}}{1+e^z} = \frac{e^{\alpha(i\pi+\zeta)}}{1+e^{i\pi+\zeta}} = \frac{e^{\alpha(i\pi+\zeta)}}{1-e^\zeta} = \frac{e^{i\alpha\pi}(1+\zeta+\dots)}{1-(1+\zeta+\dots)},$$

and so the residue at $z = i\pi$ (i.e. at $\zeta = 0$) is $-e^{i\alpha\pi}$. Thus, by the residue theorem, we have

$$\oint_C \frac{e^{\alpha z}}{1+e^z} dz = 2\pi i(-e^{i\alpha\pi}) = -2\pi i e^{i\alpha\pi}.$$

Now we may write the contour integral as

$$\int_{-R}^R \frac{e^{\alpha x}}{1+e^x} dx + \int_0^{2\pi} \frac{e^{\alpha(R+iy)}}{1+e^{R+iy}} idy + \int_R^{-R} \frac{e^{\alpha(x+2\pi i)}}{1+e^{x+2\pi i}} dx + \int_{2\pi}^0 \frac{e^{\alpha(-R+iy)}}{1+e^{-R+iy}} idy (= -2\pi i e^{i\alpha\pi}).$$

However, we note that

$$\left| \int_0^{2\pi} \frac{e^{\alpha(R+iy)}}{1+e^{R+iy}} i dy \right| \leq \int_0^{2\pi} \left| \frac{e^{\alpha(R+iy)}}{1+e^{R+iy}} \right| dy$$

$$\leq \frac{e^{\alpha R}}{e^R - 1} 2\pi \rightarrow 0 \text{ as } R \rightarrow \infty$$

for $0 < \alpha < 1$; similarly

$$\left| \int_{2\pi}^0 \frac{e^{\alpha(-R+iy)}}{1+e^{-R+iy}} i dy \right| \leq \int_0^{2\pi} \left| \frac{e^{\alpha(-R+iy)}}{1+e^{-R+iy}} \right| dy$$

$$\leq \frac{e^{-\alpha R}}{1-e^{-R}} 2\pi \rightarrow 0 \text{ as } R \rightarrow \infty.$$

Finally, we also have

$$\int_R^{-R} \frac{e^{\alpha(x+2\pi i)}}{1+e^{x+2\pi i}} dx = -e^{2\alpha\pi i} \int_{-R}^R \frac{e^{\alpha x}}{1+e^x} dx,$$

and so, taking $R \rightarrow \infty$, we obtain

$$(1 - e^{2\alpha\pi i}) \int_{-\infty}^{\infty} \frac{e^{\alpha x}}{1+e^x} dx = -2\pi i e^{i\alpha\pi}$$

$$\text{or } (e^{\alpha\pi i} - e^{-\alpha\pi i}) \int_{-\infty}^{\infty} \frac{e^{\alpha x}}{1+e^x} dx = 2\pi i$$

$$\text{i.e. } 2i \sin(\alpha\pi) \int_{-\infty}^{\infty} \frac{e^{\alpha x}}{1+e^x} dx = 2\pi i.$$

Hence we have the evaluation

$$\int_{-\infty}^{\infty} \frac{e^{\alpha x}}{1+e^x} dx = \frac{\pi}{\sin(\alpha\pi)},$$

where α is real, with $0 < \alpha < 1$.

This result should be no surprise: cf. Example 12. Let us write $y = e^x$, with $-\infty < x < \infty$ (so that $0 < y < \infty$), then we obtain

$$\int_{-\infty}^{\infty} \frac{e^{\alpha x}}{1+e^x} dx = \int_0^{\infty} \frac{y^{\alpha}}{1+y} \frac{1}{y} dy = \int_0^{\infty} \frac{y^{\alpha-1}}{1+y} dy = \int_0^{\infty} \frac{y^{-k}}{1+y} dy = \frac{\pi}{\sin(k\pi)}$$

from Example 12, where $k = 1 - \alpha$ (so $0 < k < 1$) and also

$$\sin(k\pi) = \sin[(1 - \alpha)\pi] = \sin(\alpha\pi).$$

(b) A sector of a circle

This is the problem of evaluating $\int_0^{\infty} \cos(x^2) dx$, and the obvious choice for a function in the complex plane is $\exp(iz^2)$ (so th

.....Alcatel-Lucent 

www.alcatel-lucent.com/careers

What if you could build your future and create the future?

One generation's transformation is the next's status quo. In the near future, people may soon think it's strange that devices ever had to be "plugged in." To obtain that status, there needs to be "The Shift".



$$\oint_C e^{iz^2} dz.$$

The most convenient and straightforward method for the evaluation of this integral (which we may note is the integral of an *entire* function) is to incorporate the standard result $\int_0^\infty e^{-y^2} dy = \frac{1}{2}\sqrt{\pi}$.

This can be accomplished by taking, as one part of C , the line $z = re^{i\pi/4}$, for then $iz^2 = ir^2e^{i\pi/2} = -r^2$; thus we choose to use a C as shown in the figure below.

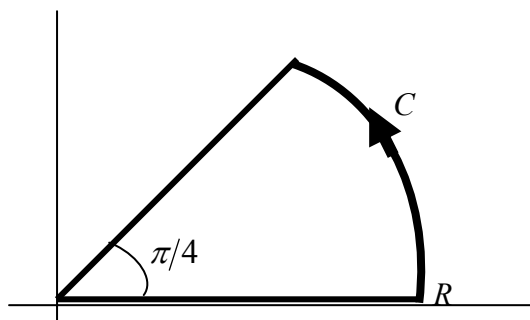

By Cauchy's integral theorem, we have

$$\oint_C e^{iz^2} dz = 0,$$

but we may write

$$\oint_C e^{iz^2} dz = \int_0^R e^{ix^2} dx + \int_0^{\pi/4} \exp(iR^2 e^{2i\theta}) Rie^{i\theta} d\theta + \int_R^0 \exp(ir^2 e^{i\pi/2}) e^{i\pi/4} dr (= 0).$$

Here, we see that

$$\left| iR \int_0^{\pi/4} e^{i\theta} \exp(iR^2 e^{2i\theta}) d\theta \right| \leq R \int_0^{\pi/4} e^{-R \sin 2\theta} d\theta \leq R \int_0^{\pi/4} e^{-4R^2 \theta/\pi} d\theta$$

because $|e^{i\theta}| = 1$, $|\exp(iR^2 e^{2i\theta})| = |\exp[iR^2(\cos 2\theta + i \sin 2\theta)]| = \exp(-R^2 \sin 2\theta)$ and $\sin 2\theta \geq 4\theta/\pi$ for $0 \leq \theta \leq \pi/4$. Thus we have

$$\left| iR \int_0^{\pi/4} e^{i\theta} \exp(iR^2 e^{2i\theta}) d\theta \right| \leq \frac{1}{4} \pi R^{-1} (1 - e^{-R^2}) \rightarrow 0 \text{ as } R \rightarrow \infty,$$

and so when we take $R \rightarrow \infty$, we are left with

$$\int_0^{\infty} e^{ix^2} dx - e^{i\pi/4} \int_0^{\infty} e^{-r^2} dr = 0 \text{ or } \int_0^{\infty} e^{ix^2} dx = \frac{1}{\sqrt{2}}(1+i) \int_0^{\infty} e^{-r^2} dr = \frac{1}{\sqrt{2}}(1+i) \frac{1}{2} \sqrt{\pi}.$$

The real part of this equation then gives

$$\int_0^{\infty} \cos(x^2) dx = \frac{1}{2} \sqrt{\frac{\pi}{2}},$$

which is the required value. (Note that the corresponding integral for *sin* yields, from the imaginary part, the same value: $\int_0^{\infty} \sin(x^2) dx = \sqrt{\pi}/2\sqrt{2}$.)

Exercises 4

Evaluate these real integrals: (a) $\int_0^{\infty} \frac{(\ln x)^2}{1+x^2} dx$; (b) $\int_0^{\infty} \frac{x - \sin x}{x^3} dx$.



Join the best at the Maastricht University School of Business and Economics!

Top master's programmes

- 33rd place Financial Times worldwide ranking: MSc International Business
- 1st place: MSc International Business
- 1st place: MSc Financial Economics
- 2nd place: MSc Management of Learning
- 2nd place: MSc Economics
- 2nd place: MSc Econometrics and Operations Research
- 2nd place: MSc Global Supply Chain Management and Change

Sources: Keuzegids Master ranking 2013; Elsevier 'Beste Studies' ranking 2012; Financial Times Global Masters in Management ranking 2012

Maastricht
University is
the best specialist
university in the
Netherlands
(Elsevier)

Visit us and find out why we are the best!
Master's Open Day: 22 February 2014

www.mastersopenday.nl



5 Integration of rational functions of trigonometric functions

The final type of integral that we consider takes a rather different form; indeed, the problem and the approach to its solution harks back to standard methods of elementary integration: substitution. Essentially all we do is to introduce a routine change of variable – the substitution – and then integrate, except that here we generate an integral in the complex plane that can be evaluated by using the residue theorem. We should comment that all such integrals can be evaluated by conventional means, i.e. by using a standard (real) substitution, but the definite integrals that arise are far more easily computed by these new methods. We shall consider definite integrals of the form

$$\int_0^{2\pi} f(\sin \theta, \cos \theta) d\theta,$$

where f is a rational function of its arguments; a simple example is

$$\int_0^{2\pi} \frac{\sin \theta}{3 + 2 \cos \theta} d\theta.$$

The method involves using the familiar identification $z = e^{i\theta}$, so that $0 \leq \theta \leq 2\pi$ will map out the unit circle, $|z| = 1$, in the counter-clockwise direction; we will label this contour C_0 . We also have

$$\begin{aligned} \frac{dz}{d\theta} &= ie^{i\theta} = iz, & \cos \theta &= \frac{1}{2}(e^{i\theta} + e^{-i\theta}) = \frac{1}{2}(z + z^{-1}), \\ \sin \theta &= \frac{1}{2i}(e^{i\theta} - e^{-i\theta}) = \frac{1}{2i}(z - z^{-1}), \end{aligned}$$

and so we may write

$$\int_0^{2\pi} f(\sin \theta, \cos \theta) d\theta = \oint_{C_0} f\left(\frac{1}{2i}(z - z^{-1}), \frac{1}{2}(z + z^{-1})\right) \left(-i \frac{dz}{z}\right).$$

But since f is rational, it remains rational under this transformation to z , and hence we can readily identify the poles (and the residues) inside C_0 , the unit circle.

Example 13

Evaluate $\int_0^{2\pi} \frac{d\theta}{1+k \sin \theta}$ where $0 < |k| < 1$ (and k is real). (The condition on k is necessary if the integral is to exist.)

We introduce $z = e^{i\theta}$ with $\sin \theta = \frac{1}{2i}(z - z^{-1})$, so we have

$$\begin{aligned} \int_0^{2\pi} \frac{d\theta}{1+k \sin \theta} &= \oint_{C_0} \frac{1}{1 - \frac{1}{2}ik(z - z^{-1})} \left(-i \frac{dz}{z}\right) \\ &= \oint_{C_0} \frac{dz}{iz + \frac{1}{2}k(z^2 - 1)} = \frac{2}{k} \oint_{C_0} \frac{dz}{z^2 + \frac{2i}{k}z - 1}, \end{aligned}$$

where $z^2 + (2i/k)z - 1 = 0$ at $z = \frac{i}{k}(-1 \pm \sqrt{1 - k^2})$. The root with the positive square root corresponds to a point inside the unit circle; the other point lies outside. Thus we write

$$\frac{1}{z^2 + \frac{2i}{k}z - 1} = \frac{1}{\left(z + \frac{i}{k} - \frac{i}{k}\sqrt{1 - k^2}\right)\left(z + \frac{i}{k} + \frac{i}{k}\sqrt{1 - k^2}\right)}$$

and so the residue (of this function) at $z = -\frac{i}{k} + \frac{i}{k}\sqrt{1 - k^2}$ is

$$\frac{1}{-\frac{i}{k} + \frac{i}{k}\sqrt{1 - k^2} + \frac{i}{k} + \frac{i}{k}\sqrt{1 - k^2}} = -\frac{ik}{2\sqrt{1 - k^2}}.$$

Thus we finally obtain

$$\int_0^{2\pi} \frac{d\theta}{1+k \sin \theta} = \frac{2}{k} 2\pi i \left(-i \frac{k}{2\sqrt{1 - k^2}}\right) = \frac{2\pi}{\sqrt{1 - k^2}}.$$

It is convenient, and often very useful, to note that $\sin n\theta$ and $\cos n\theta$ can be expressed as rational functions of $\sin \theta$ and $\cos \theta$, so more involved trigonometric terms can appear in the integrand, without causing – as we shall see – undue algebraic complications (which might have been expected). So, given $e^{i\theta} = \cos \theta + i \sin \theta$, we have

$$e^{in\theta} = (\cos \theta + i \sin \theta)^n = \cos n\theta + i \sin n\theta,$$

which is the very familiar *de Moivre's theorem*; then we may write

$$\cos n\theta = \frac{1}{2}(e^{in\theta} + e^{-in\theta}) = \frac{1}{2}(z^n + z^{-n})$$

and
$$\sin n\theta = \frac{1}{2i}(e^{in\theta} - e^{-in\theta}) = \frac{1}{2i}(z^n - z^{-n}),$$

which considerably simplifies the process of substitution. [A. de Moivre, 1667-1754, French mathematician who developed the field of analytical trigonometry; he was severely persecuted for his Protestant faith.]

Example 14 Evaluate $\int_0^{2\pi} \frac{\cos 2\theta}{(1 - \frac{4}{5} \cos \theta)^2} d\theta.$ _____

We introduce $z = e^{i\theta}$ with $\cos \theta = \frac{1}{2}(z + z^{-1})$ and $\cos 2\theta = \frac{1}{2}(z^2 + z^{-2})$; thus we obtain

$$\begin{aligned} \int_0^{2\pi} \frac{\cos 2\theta}{(1 - \frac{4}{5} \cos \theta)^2} d\theta &= \oint_{C_0} \frac{\frac{1}{2}(z^2 + z^{-2})}{[1 - \frac{2}{5}(z + z^{-1})]^2} \left(-i \frac{dz}{z}\right) \\ &= -\frac{i}{2} \oint_{C_0} \frac{z^3 + z^{-1}}{4\left(z^2 - \frac{5}{2}z + 1\right)^2} dz. \end{aligned}$$

Now $z^2 - \frac{5}{2}z + 1 = (z - 2)\left(z - \frac{1}{2}\right)$, so we have one root of this quadratic expression that lies inside the unit circle (at $z = 1/2$). Thus it is convenient to write

> Apply now

REDEFINE YOUR FUTURE
AXA GLOBAL GRADUATE PROGRAM 2015

redefining / standards 

agence c&g © Photonstop



$$\int_0^{2\pi} \frac{\cos 2\theta}{\left(1 - \frac{4}{5} \cos \theta\right)^2} d\theta = -\frac{25}{8} i \oint_{C_0} \frac{1+z^4}{z(z-2)^2\left(z-\frac{1}{2}\right)^2} dz$$

which has poles at $z = 0$ and at $z = 1/2$ inside the contour; the residue at $z = 0$ is

$$-\frac{25}{8} i \frac{1}{(-2)^2(-1/2)^2} = -\frac{25}{8} i.$$

The residue at $z = 1/2$ is obtained by writing $z = \frac{1}{2} + \zeta$, then we obtain

$$\begin{aligned} &-\frac{25}{8} i \frac{1 + \left(\frac{1}{2} + \zeta\right)^4}{\left(\frac{1}{2} + \zeta\right)\left(-\frac{3}{2} + \zeta\right)^2 \zeta^2} \\ &= -\frac{25}{8} i \frac{8}{9\zeta^2} \left(\frac{17}{16} + \frac{1}{2}\zeta + \dots\right)(1 - 2\zeta + \dots)\left(1 + \frac{4}{3}\zeta + \dots\right) \\ &= \dots - \frac{25}{9} i \frac{1}{\zeta} \left(\frac{1}{2} - \frac{17}{8} + \frac{17}{12}\right) + \dots, \end{aligned}$$

and so the residue at $z = 1/2$ is

$$-\frac{25}{9} i \left(\frac{1}{2} - \frac{17}{8} + \frac{17}{12}\right) = \frac{125}{216} i.$$

Thus we finally have the evaluation

$$\int_0^{2\pi} \frac{\cos 2\theta}{\left(1 - \frac{4}{5} \cos \theta\right)^2} d\theta = 2\pi i \left(-\frac{25}{8} i + \frac{125}{216} i\right) = \frac{275}{54} \pi.$$

Exercises 5

Evaluate these real integrals:

$$(a) \int_0^{2\pi} \frac{d\theta}{(1+3\cos^2 \theta)^2}; (b) \int_0^{2\pi} \frac{d\theta}{1+a \sin \theta + b \cos \theta} \quad (a^2 + b^2 < 1).$$

Answers

Exercises 1

1. & 2. $-\frac{97}{12} - i\frac{13}{6}$.

3. (a) 1; (b) $\frac{1}{10}(1+i)$.

Exercises 2

1. (a) 0; (b) $-2\pi i \sin 2$.

2. (a) $\frac{1}{2}\pi i$; (b) $\frac{1}{2}\pi i(1+2\sinh 2 - \cos 2)$.

Exercises 3

(a) $\frac{\pi}{6}$; (b) $\frac{\pi}{2}$; (c) $\frac{\pi}{4e}(\sin 1 + \cos 1)$.

Exercises 4

(a) $\frac{\pi^3}{8}$; (b) $\frac{\pi}{4}$.

Exercises 5

(a) $\frac{5\pi}{8}$; (b) $\frac{2\pi}{\sqrt{1-(a^2+b^2)}}$.

Biographical Notes

In these notes, we provide some biographical information, in brief, about the various figures who have contributed to the theory of complex variables (and numbers) over the last two centuries, or so.

Jean Robert ARGAND (1768-1822)

Argand was a French-speaking native of Switzerland – he was born in Geneva – who worked all his life as an accountant and bookkeeper in Paris; he was ‘only’ an amateur mathematician. He published his work on the representation of complex numbers in 1806, in a small book that he had published privately. It was not circulated, at the time, amongst the body of mathematicians who would have been interested; however, it was discovered (initially without any clue as to who wrote it) in 1813, and an advert put in the press to find its author. Argand responded, and thereafter continued to work on various problems of some importance. Indeed, although he has received little credit for it, he was the first to give a virtually complete proof of the fundamental theorem of algebra in the case where the coefficients are complex numbers.



It should be recorded, however, that Argand was not the first to develop the geometrical interpretation of complex numbers. This was accomplished by Caspar Wessel (a Norwegian surveyor) in 1787, who published the work in a journal sponsored by the Royal Danish Academy of Sciences. Sadly, this was not read by the leading mathematicians of the day – indeed, it was not rediscovered until 1895!

Empowering People. Improving Business.

BI Norwegian Business School is one of Europe's largest business schools welcoming more than 20,000 students. Our programmes provide a stimulating and multi-cultural learning environment with an international outlook ultimately providing students with professional skills to meet the increasing needs of businesses.

BI offers four different two-year, full-time Master of Science (MSc) programmes that are taught entirely in English and have been designed to provide professional skills to meet the increasing need of businesses. The MSc programmes provide a stimulating and multi-cultural learning environment to give you the best platform to launch into your career.

- MSc in Business
- MSc in Financial Economics
- MSc in Strategic Marketing Management
- MSc in Leadership and Organisational Psychology

BI NORWEGIAN BUSINESS SCHOOL

EFMD **EQUIS** ACCREDITED

www.bi.edu/master



Augustin-Louis CAUCHY (1789-1857)

Cauchy was arguably the leading French mathematician of his day, although he trained as a military engineer; however, because of poor health, he discontinued this profession in 1813 and thereafter committed himself to the study of mathematics, full-time; he was appointed Professor at the École Polytechnique in 1816. In terms of productivity, he was second only to Euler in the number of papers and books that he published: 7 books and 789 research papers. He made very significant contributions to many branches of mathematics: number theory, theory of finite groups, astronomy, mechanics, optics and the theory of elasticity. However, his most important work was in analysis. Here, he made precise and rigorous the notions of limits, continuity, derivatives, integrals and series. In the case of the last mentioned, he provided us with a number of basic tests that we use today, in order to examine the convergence of infinite series. He also worked on existence proofs for solutions of differential equations, and applied his techniques and discoveries concerning infinite series to both Taylor series and Fourier series. Notwithstanding all the above, he is probably best remembered for laying the foundations of, and developing almost single-handedly, the theory of functions of a complex variable – one of the most powerful and all-pervading theories in mathematics. Although others before him had used complex quantities, particularly in transformations of integrals – for example Gauss, Euler and Laplace – this had been done in a purely algebraic way: simply use a change of variable that happened to be complex-valued. Cauchy was the first to define, and investigate, contour integrals in the complex plane, which led him to his fundamental theorems (Cauchy Theorem, the Cauchy Integral Formula and the Residue Theorem, not to mention the Cauchy-Riemann relations). This provides the basis for all of complex analysis, and for many important applications in mathematical physics (and aerodynamics in particular).



Cauchy, we should mention, was not well-liked by his fellow mathematicians. He was regarded by many as arrogant and rude, and was not averse to attacking other scientists on religious grounds (he was an ardent Catholic). Indeed Abel, describing a meeting with him, recorded that he 'is mad and there is nothing that can be done about him, although, right now, he is the only one who knows how mathematics should be done'. We conclude on a fairly positive note: he was an outstanding mathematician, who was deeply committed to his subject, even if he was somewhat narrow-minded! After all, he gave us, at a conservative estimate, about 16 fundamental concepts or theorems that revolutionised both pure and applied mathematics.

Leonhard EULER (1707-1783)

Euler was a native of Basel, in Switzerland, where he studied at the university, initially under the tutelage of Johann Bernoulli. He is remembered for his enormous range of contributions and, above all, for his prodigious mental powers. Indeed, when he went completely blind in about 1771, he was able to continue working, producing nearly half of his total output of papers between then and his death: he did all the calculations in his head, his students and assistants recording the results. He spent most of his working life, first in St Petersburg, then in Berlin, finally returning to St Petersburg



in 1766; he was a respected scientist in the pay of Catherine the Great and Frederick the Great (often both funding him at the same time!). In his eagerness to study the sun, early in his career, he looked at the sun through a telescope; this, probably coupled with a severe fever, led to the loss of his right eye by about 1740. He continued to have problems with the sight in his left eye, eventually losing his sight altogether.

Euler was not just a mathematician; he also supervised the observatory and botanical gardens in Berlin, and was responsible for the publication of calendars and maps (which provided income for the Academy of Sciences in Berlin). He also took responsibility for canal projects, city water-pumping stations and other hydraulic systems, not to mention giving governments advice on state lotteries, insurance and pensions, and also on various military matters. Yet with all this he led a full family life – he was happily married and had 13 children – and was a deeply committed Christian. With all this, he managed to produce more titles than any other mathematician: 887 papers and books. (You might want to check on Saharon Shelah: a modern update on this record?) In 1911, a project was started to print all Euler's works in a many-volume set; the plan was for about 72 volumes, but when his private papers were studied, it was found that there was enough material for about another 30 volumes – and this project is not yet completed. His rate of working was phenomenal; for example, over a period of about 7 years, during the latter part of his life when he was totally blind, he produced material for about 250 published papers.

He made fundamental contributions to analysis in general, and in particular to number theory, the calculus and geometry. He also worked in continuum mechanics (elasticity, fluid mechanics, acoustics), celestial mechanics (e.g. the three-body problem) and introduced many standard techniques (e.g. integrating factors for solving differential equations); he standardised much of our (now familiar) notation. He is regarded as the father of analytical mechanics and of fluid mechanics.

To mention a little of his work, in detail, which is relevant to elementary mathematics, and to our study of the functions of a complex variable, we note the following. Euler introduced the notation $f(x)$ (in 1734) for a function, and was the first to treat the trigonometric functions as such; before him, these were used merely to compute lengths and angles in specific geometrical contexts. He also generated and used the power-series representations of these functions. He used 'e' for the base of the natural logarithm (1727), 'i' for $\sqrt{-1}$ (1777) and Σ for summation (1755). Although he did not introduce π – this was due to William Jones in 1706 – he made it popular after about 1739 (before which he usually wrote p for π). He obtained numerous series-representations for π e.g.

$$\frac{\pi^2}{6} = 1 + \frac{1}{2^2} + \frac{1}{3^2} + \frac{1}{4^2} + \dots .$$

He also obtained (in 1748) the fundamental identity

$$e^{ix} = \cos x + i \sin x ,$$

and then his 'most beautiful result': $e^{i\pi} + 1 = 0$. Indeed, he investigated functions of a complex variable in a number of different contexts, although – it would appear – not as a specific branch of mathematics. He came across the Cauchy-Riemann relations in 1777 (as had d'Alembert in 1752), but he used them only as they arose in specific problems.

Jean Baptiste Joseph FOURIER (1768-1830)

Fourier was the mathematical physicist who devoted much of his time and energy to understanding, and describing in mathematical terms, how heat is transferred between bodies and inside bodies. In the process of developing the appropriate governing equations (of what we now call heat conduction), he introduced completely new mathematical ideas and techniques. He entered, at the age of 12, the military academy in Auxerre (which is where he was born), where his interests and abilities in mathematics soon became evident. However, he decided (aged 19) to train for the priesthood – he joined a Benedictine abbey – although he never lost his interest in mathematics; indeed, he corresponded with a few mathematicians and published some minor work. He did not take his vows, but left for Paris at the start of the Revolution (1789) and, somewhat reluctantly, was drawn into the complicated politics of the time. Once the dust had settled, he began to train as a teacher in Paris (at the recently-opened École Normale). He began teaching in his old school in Auxerre, but maintained regular contact with the leading mathematicians in France at the time: Lagrange, Laplace and Monge.



He was noticed by Napoleon, and persuaded to join the army as a scientific adviser when Egypt was invaded. He was, thereafter, required to take a number of administrative posts back in France; at about this time he wrote a *Description of Egypt* (which took much of his time before its completion in 1810). Yet he was able (from about 1804-1807) to write his first significant memoir (on the propagation of heat in solid bodies); this was followed (1822) by his most celebrated work: *Théorie analytique de la chaleur*.

Need help with your dissertation?

Get in-depth feedback & advice from experts in your topic area. Find out what you can do to improve the quality of your dissertation!

Get Help Now



Go to www.helpmyassignment.co.uk for more info

 **Helpmyassignment**

Fourier was the first to use partial differential equations as the basis for a complete description of a physical phenomenon. To complete the mathematical construction, he had to invent the technique of ‘separation of variables’, resulting in a set of ordinary differential equations, solve these and then impose boundary (and initial) conditions. The resulting solution, however, could be written only in a series of trigonometric terms: the Fourier series. This approach caused much controversy (and this started back in 1808 when he first hinted at this method of solution) because there was grave doubt about the correctness of this representation (in a series of *sin* and *cos* terms) for general functions. (It should be remembered that, at this time, the only series that were generally accepted were powers series i.e. Taylor or Maclaurin series, although some use had been made of series in Bessel functions or Legendre polynomials, but without any justification.) A number of noted mathematicians then took up the challenge to prove – or disprove – that Fourier series were acceptable mathematical animals. This charge was led by Dirichlet, and it was he who was able to construct (1829) a satisfactory proof of their existence i.e. convergence, and this included the possibility of allowing discontinuous functions (which had already been hinted at as a consequence of Fourier’s work). Indeed, Dirichlet was, based on this important work, able to introduce the modern concept of a function.

Fourier also introduced what we now recognise as the *Fourier Transform*, by considering what happens if the domain in which heat is flowing is extended to infinity. The main reason behind this approach was to generate ‘closed-form’ solutions, rather than an infinite series – even if the integral could not be simplified in any meaningful way! (Closed-form solutions were all the rage at the time.) This particular approach was developed by Cauchy (1816), in the context of the theory of water-wave propagation, who then obtained both the transform and its inverse.

Fourier also made important contributions to the theory of equations, probability theory and the theory of errors, as well as laying the foundations for the development of dimensional analysis and for linear programming.

Edouard Jean-Baptiste GOURSAT (1858-1936)

Goursat obtained his doctorate in 1881 (from the École Normale Supérieure), and thereafter taught mathematics – mainly analysis – at a number of universities in France, finishing his career at the University of Paris. Two of his teachers were Darboux and Hermite, and he was much influenced by their approach to analysis. His lasting claim to fame is that he was able (1900) to generalise Cauchy’s fundamental result on the integral of analytic functions around a closed contour. He demonstrated that it was sufficient for $f(z)$ and its derivative to *exist* inside and on the contour – it was not necessary for the derivative to be continuous. Indeed, he showed that this same condition on the function and its derivative is sufficient to guarantee analyticity.

Goursat produced an important text (*Cours d’analyse mathématique*) in which he introduced many new and important concepts in analysis. He also improved some theorems, originally formulated by Cauchy and by Kovalevsky, on the existence of solutions of systems of differential equations.



Marie Ennemond Camille JORDAN (1838-1922)

Jordan studied mathematics at the École Polytechnique in Paris, where training as an engineer was offered to all students (and it was expected that most, if not all, would qualify as engineers). He did qualify and, indeed, worked professionally as an engineer, during which time he developed his mathematical ideas; he returned to the École in 1873 to teach mathematics – his doctorate was on algebra and a class of integrals – and was appointed Professor of Analysis in 1876.

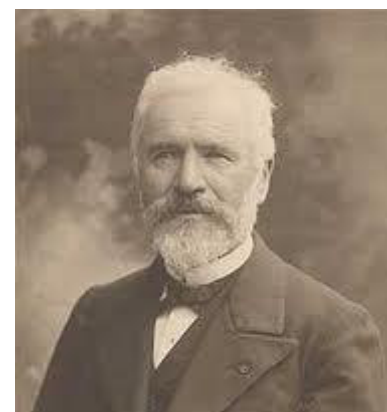

He worked in almost every branch of mathematics that was commonly studied towards the end of the nineteenth century. Thus he made contributions to finite groups, linear algebra, number theory, topology (specifically of polyhedra), differential equations and mechanics. He developed, from the ideas of Galois, the theory of finite groups which led him to the concept of the infinite group. He produced a text on group theory (1870), which remained the standard text for over 30 years. In topology, which is the main interest for us in the context of complex analysis, he introduced the homotopy (of paths), building on the work of Riemann. Indeed, he defined the homotopy group of a surface, but without any explicit use of group theory – even though he was one of its founders! He is most notably remembered today, in the field of analysis, for his proof that a simple, closed curve divides a plane into exactly two regions. (It was Jordan's very fine understanding of mathematical rigour, and of proof, that enabled him to realise that such a result was important and necessary, and that it had to be proved.) We are now fairly comfortable with the notion of a Jordan curve, and the deformation of one such curve into another; it is this concept that we use in the study of contour integrals.

Towards the end of his life, he was greatly saddened and personally affected by the First World War; he had six sons, three of whom were killed between 1914 and 1916. The other three rose to prominent positions in government or the professions.

Pierre-Simon de LAPLACE (1749-1837)

Laplace was born into a wealthy Normandy family, and attended a Benedictine priory school; it was expected that he would enter either the church or the army – the usual route followed by pupils at this school. Indeed, he initially studied theology at university, but it was not long before he discovered mathematics, and his love of it and ability at it. He left university, without graduating, and moved to Paris; here, he was soon recognised by the French mathematicians as possessing outstanding talents. By the age of 21, without any formal mathematical education or training, he presented his first paper to the Academy of Sciences in Paris. Thereafter, he maintained a steady stream – almost a flood – of high-quality papers on a considerable range of topics, although his abiding passions were celestial mechanics and probability theory. At the same time, he held a number of important positions, first in the revolutionary government, and then under Napoleon; he wisely voted for the overthrow of Napoleon, and following this Charles X raised him to the status of *marquis*.



He was, throughout his life, committed to the theory of Newtonian gravity, and did much to confirm the complete correctness of this model of the Universe (outside relativistic considerations, of course). He solved many of the outstanding problems that had been encountered by astronomers; some of these observations appeared to contradict Newtonian theory, but Laplace was able to demonstrate that everything was consistent, even if a few-body interactions were needed. He also introduced the potential function and applied it, in particular, to calculations involving gravity. Laplace's equation, which is the equation satisfied by a potential function, was first obtained by Euler (1752); Laplace, however, used this equation in different coordinate systems and solved many different problems with it. (So, although he certainly did not give us 'his' equation, it is not unreasonable to name it after him.) The bulk of his work on celestial mechanics (*Traité de Mécanique Céleste*) was published in five volumes, between 1799 and 1825; in it, he aimed to present a complete analytical solution of all mechanical problems posed by the existence of the Universe – including the important demonstration that our solar system is stable.

Laplace's work on probability (covered in *Théorie Analytique des Probabilités*, first published in 1812) discusses generating functions and various approximations that are needed in probability theory. Then it moves on to a definition of probability, discusses Bayes' rule, with some discussion of expectations – both mathematical and moral. Many problems, involving compound events, are considered, together with related topics, such as applications to life expectancy and errors in observations.

We should mention that Laplace was not modest about his abilities; he also very rarely acknowledged any work that preceded his own. A visitor to Paris in 1870 noted that Laplace let it be known that he considered himself the finest French mathematician alive – and he was probably correct! He married in 1788, his wife being 20 years his junior; they had a son and a daughter, although the daughter died in childbirth in 1813, but the child survived and maintained the Laplace line (because Laplace's son had no children).

Brain power

By 2020, wind could provide one-tenth of our planet's electricity needs. Already today, SKF's innovative know-how is crucial to running a large proportion of the world's wind turbines.

Up to 25 % of the generating costs relate to maintenance. These can be reduced dramatically thanks to our systems for on-line condition monitoring and automatic lubrication. We help make it more economical to create cleaner, cheaper energy out of thin air.

By sharing our experience, expertise, and creativity, industries can boost performance beyond expectations.

Therefore we need the best employees who can meet this challenge!

The Power of Knowledge Engineering

Plug into The Power of Knowledge Engineering.
Visit us at www.skf.com/knowledge

SKF

Pierre Alphonse LAURENT (1813-1854)

Laurent was trained as an engineer and then joined the army, as a member of the engineering corps, and was sent to Algeria in the mid-1830s. He returned to France in about 1840, being appointed as the director of operations involved in the enlargement of the port of Le Havre. It was at this time that he started to work seriously at mathematics; he submitted a paper (for a prize offered by the Academy of Sciences) on the calculus of variations. This was not considered for a prize – he was late submitting it – although it was highly regarded, but not published with the other submissions. This paper contains his power series (the Laurent expansion) for a function of a complex variable. It is worth noting that Cauchy reported on this paper, and a sequel, and recommended publication, but the editors for the relevant journal declined to follow his advice. However, the first paper did appear in 1843; the second has been lost. (It is intriguing to note that this generalisation of a power series was known to Weierstrass in about 1841, but he never published it.)

The reaction to his work was a bitter disappointment to Laurent, who promptly decided to follow another path of investigation. He decided to study light waves and, in particular, the phenomenon of polarisation, publishing a number of papers on this topic. He continued to serve in the army, was promoted to major and was appointed to a committee to investigate the state of fortifications around the country. Until his early death, he made contributions to various problems in applied mathematics.

Joseph LIOUVILLE (1809-1882)

Liouville began his studies, in advanced mathematics, at the Collège St Louis, in Paris. He attended various courses given by Ampère (on analytical mechanics), and eventually moved to an academic career (after a bout of ill health), holding a number of posts at various écoles in Paris. Although his initial interests, and results, were concerned with electricity and heat – and he was also a member of the astronomy section of the French Academy of Sciences – his most important and influential work was in analysis.



He made many important discoveries; for example, he was the first to solve a boundary-value problem for a partial differential equation in terms of an integral equation (which became a major field of analysis after about 1900). As modern students of mathematics will know, he made significant discoveries (with his collaborator Sturm) in the theory of second-order ordinary differential equations. He also clarified the notion of fractional derivatives, and also showed that many types of integral (including some elliptic integrals) could be expressed, in closed form, in terms of elementary functions. Another area that intrigued him was the whole concept of transcendental numbers. He hoped to prove that 'e' is transcendental; he failed, but laid the foundations for Hermite's proof for 'e' (1873), and then Lindemann's for π (1882). However, he constructed many transcendental numbers, and provided a sufficient condition for transcendency.

For us, his work in complex variables led to a fundamental result: that a bounded, entire function is necessarily a constant. He also made contributions to differential geometry and Hamiltonian mechanics.

Liouville had a rather unusual life style: he would do research for six months over the summer period (in his home in Toul – he was married), and then devote six months (over the winter) teaching in Paris. He also dabbled in politics, spending a short period as a member of the Assembly; in his professional career he did not always get the post he thought that he deserved, but he was eventually (1851) appointed to a chair in mathematics at the Collège de France.

Georg Friedrich Bernhard RIEMANN (1826-1866)

Many modern mathematicians take the view that Riemann has no equal in the influence that his mathematics has had on the developments of the 20th century. For many, it is his work on non-Euclidean geometry and topological spaces which laid the foundations for Einstein's theory of relativity that is pre-eminent. Others might choose from the vast range of other contributions that he made. It is worth imagining what else he might have achieved, had he lived to a full age; sadly, he contracted TB in the autumn of 1862 (shortly after he married a friend of his sister) and died four years later. So where do we start?



Perhaps the natural place is with his doctoral thesis, in which he discussed the theory of complex variables; this became a milestone in complex-function theory. He used topological ideas, introduced 'Riemann surfaces' to help the discussion and representation of multi-valued functions, and linked all this to more geometrical properties of complex variables and conformal transformations. This work, and the way he discussed analytic functions, is now subsumed into the familiar 'Cauchy-Riemann relations'. Gauss was his examiner, and he described Riemann as having a 'gloriously fertile originality'. Gauss recommended him for a post at Göttingen, where he worked towards the degree ('habilitation') that would allow him to teach at university level. This thesis, which looked at integrability through trigonometric series, led to his fundamental ideas embodied in the 'Riemann integral'. The culmination of the work for his habilitation required him to give a lecture; this was on an aspect of geometry. In this lecture, he discussed the problem of defining n -dimensional space, introducing what we now call 'Riemannian space', and he also touched on deep questions concerning the dimension of 'real' physical space, and what geometry we should use to describe it. (Much of this was far beyond the audience – and most scientists – at the time (except Gauss); only in the last 100 years or so have we begun to appreciate the significance of this material.) Riemann, although he was not appointed to Gauss' chair at his death in 1855, was given a 'personal' chair two years later.

At about this time, he published a paper on Abelian functions, expanding the work that he had started in his doctoral thesis; on the back of his successes so far, he was elected to the Berlin Academy of Sciences. Then he turned to a study of the zeta function – often referred to nowadays as the 'Riemann-zeta function' – and proposed his famous conjecture: that the zeta function has infinitely many non-trivial roots and that the real part of every one is $1/2$. He also gave estimates for the number of primes less than a given number.

Riemann was not prolific, by any standards, yet virtually every paper that he published contains profound ideas that have changed mathematics and moved us forward in great strides. He produced work that was a breakthrough in all branches of mathematics cited above – and we are still reaping the benefits of his brilliance.

Eugène ROUCHÉ (1832-1910)

Rouché was born in southern France, and followed a conventional career-path for a mathematician: undergraduate and postgraduate studies, teacher and then professor (at the Conservatoire des Arts et Métiers in Paris). He wrote a number of texts, including one that provided an introduction to the calculus for engineers.



He is remembered for two results in particular. The first is the familiar condition that states that a system of linear equations has a solution if, and only if, the rank of the matrix of the associated homogeneous system is equal to the rank of the augmented matrix of the system; this first appeared in 1875, and in an expanded form in 1880. The second result is the one that is relevant to functions of a complex variable. In 1862, he showed that, given two complex functions, $f(z)$ and $g(z)$, both analytic inside and on the same contour, C , such that $|g(z)| < |f(z)|$ (and $f(z) \neq 0$ on C), then $f(z)$ and $f(z) + g(z)$ have the same number of zeros inside C . This provides a rather neat method for proving the fundamental theorem of algebra.

He was elected to be one of the three editors of the collected works of Laguerre (who died in 1866); the other two were Poincaré and Hermite.

Further Reading

A good place to start, if you are interested in the history of mathematics, mainly through the lives of mathematicians, is to use the 'MacTutor History of Mathematics' set-up by the University of St Andrews at

<http://www-history.mcs.st-andrews.ac.uk/history>

where you will also find a fine set of pictures of many mathematicians.

Index

Addition		
analytic function		37,110
arg(ument)		12
Argand plane		12
Argand, J.R.	complete rotations	17
		161
Beta function		147
binomial expansion		71
binomial theorem		22
branch cut		26,48,120,144
Cartesian form	complex number	12
Cauchy principal value		136
Cauchy, A-L.		162
Cauchy-Goursat theorem		56
Cauchy-Riemann relations		33,110,114
Cauchy's integral formula		56,60,117
Cauchy's integral theorem		53,56,114
closed contour		46
complete rotations	Argand plane	17
complex	differentiation	29
	function	20
	roots	16
complex number	addition	12
	arg(ument)	12
	Cartesian form	12
	conjugate	14
	modulus	12
	polar form	12
	product	13
	quotient	14
	real-imaginary form	12
complex plane		12
conjugate	complex number	14
conjugate harmonic functions		38
continuous function		29
contour		113
	closed	46
	deform	115
	indented	88,136,140
	keyhole	148
	rectangular	150
	sector of a circle	153
	with branch cut	144
contour integral		43
convergence		22
CR relations		33,110,114
CR relations	polar form	39
current (electrical)		12
curve	closed	110
	Jordan	111
	simple	110
De Moivre's theorem		16,157

deform contour		115
differentiation	complex	29
Entire function		37,154
equation	Laplace	38
essential singularity		121
Euler, L.		162
Euler's identity		18
expansion	Laurent	120
	Taylor	20
exponential function		23
Formula	Cauchy's integral	56,60,117
Fourier space		95
Fourier transform		93,95
	of derivatives	97
Fourier, J.B.J.		164
function	analytic	37,110
	beta	147
	complex	20
	continuous	29
	entire	37,154
	exponential	23
	gamma	28
	harmonic	38
	holomorphic	37,75,121
	hyperbolic	24
	meromorphic	75,121
	polynomial	21
	rational, of trigs	156
	regular	37
	trigonometric	24
fundamental theorem of calculus		45
Gamma function		28
Gauss' theorem		54,113
general power		27
geometrical inequality		15
Goursat, E.J.-B.		56,117,165
Green's theorem		54,113
Harmonic function		38
holomorphic function		37,75,121
hyperbolic function		24
Improper real integrals		125
indented contour		88,136,140
inequality	geometrical	15
	integral	63,66
	triangle	126
integral	contour	43
	line	42,110
	path-dependent	44
	path-independent	45
	real, evaluation of	66,84
	on semicircle	125,126

integral inequality		63,66
integrals	improper, real	125
inverse Fourier transform		95
isolated essential singularity		75
Jordan curve		111,113
Jordan, M.E.C.		166
Jordan's lemma		70,90,128
Keyhole contour		148
Laplace, P-S. de		166
Laplace's equation		38
Laurent expansion		73,120
Laurent, P.A.		168
line integral in complex plane		42,110
Liouville, J.		168
Log		26
logarithm		120
Meromorphic function		75,121
modulus		12
Morera, G.		56
Morera's theorem		56,117
multiply-connected domain		53,57
Necessary conditions	differentiability	31
Partial sum		71
path-dependent integral		44
path-independent integral		45
polar form	complex number	12
	CR relations	39
pole		75,121
	simple	77
pole of order 1		77
pole of order N		75
polynomial function		21
power series		71
principal value		26,90,136
product	complex number	13
PV		140
Quotient	complex number	14
Rational function of trig fns		156
real integrals		125
	evaluation of	66,84
	type 1	128
	type 2	132
real-imaginary form	complex number	12
rectangular contour		150
regular function		37
residue		75,122
residue theorem		80,83,120
Riemann sheets		48

Riemann, G.F.B.		169
roots	complex	16
Rouche, E.		170
Sector of a circle		153
semi-circular arc	integral along	68,125,126
semi-circular region		66
series	Laurent	120
simple pole		77
simple, closed curve		110
simply-connected domain		53
singularity		73
	essential	121
	isolated essential	75
sufficient condition	differentiability	31
symmetric Fourier transform		95
Taylor expansion		20,72
theorem	binomial	22
	Cauchy-Goursat	56
	Cauchy's integral	53,56,114
	de Moivre's	16,157
	fundamental (calculus)	45
	Gauss'	54,113
	Green's	54,113
	Morera's	56,117
	residue	80,83,120
transform	Fourier	93,95
	inverse Fourier	95
	symmetric Fourier	95
triangle inequality		126
trigonometric function		24
Unit circle		87