

# Pollution Prevention and Control: Part II

Material and Energy Balances

Paul Mac Berthouex; Linfield C. Brown



Download free books at

[bookboon.com](http://bookboon.com)

Paul Mac Berthouex & Linfield C. Brown

# **Pollution Prevention and Control: Part II**

## Material and Energy Balances

---

Pollution Prevention and Control: Part II

Material and Energy Balances

1<sup>st</sup> edition

© 2014 Paul Mac Berthouex & Linfield C. Brown & [bookboon.com](http://bookboon.com)

ISBN 978-87-403-0773-3

# Contents

<b>Preface</b>	<b>12</b>
<b>1 The Fundamentals of Design</b>	<b>14</b>
1.1 The Design Problem	14
1.2 The Fundamental Concepts	14
1.3 The Material Balance and the Energy Balance	16
1.4 Block Diagrams	16
1.5 Block Diagrams and the Material Balance	18
1.6 Inventing the Block Diagram	18
1.7 Process Flow Diagrams	20
1.8 Design Drawings and Specifications	21
1.9 Process and Instrumentation Diagrams	22
1.10 Structure of this Book	22
1.11 Conclusion	23

www.sylvania.com

We do not reinvent the wheel we reinvent light.

Fascinating lighting offers an infinite spectrum of possibilities: Innovative technologies and new markets provide both opportunities and challenges. An environment in which your expertise is in high demand. Enjoy the supportive working atmosphere within our global group and benefit from international career paths. Implement sustainable ideas in close cooperation with other specialists and contribute to influencing our future. Come and join us in reinventing light every day.

Light is OSRAM

**OSRAM SYLVANIA**





<b>2</b>	<b>Measures of Pollution</b>	<b>24</b>
2.1	The Problem	24
2.2	Pollutants	24
2.3	Units	29
2.4	Liquids, Sludge and Solids	31
2.5	Gases	34
2.6	Conclusion	41
<b>3</b>	<b>Pollution Prevention</b>	<b>43</b>
3.1	The Design Problem	43
3.2	Pollution Audit – The First Steps	44
3.3	Case Study – Sweet Potato Canning	45
3.4	Case Study – Water Reuse and Toxic Metals Management	48
3.5	Case Study – Reducing Phenol Emissions	53
3.6	Case Study – Reclaiming Gallium Arsenide from Semiconductor Manufacturing	55
3.7	Conclusion	58



Discover the truth at [www.deloitte.ca/careers](http://www.deloitte.ca/careers)

**Deloitte.**

© Deloitte & Touche LLP and affiliated entities.



Click on the ad to read more

<b>4</b>	<b>Conservation of Mass</b>	<b>59</b>
4.1	The Basic Principle	59
4.2	Accumulation of Mass	62
4.3	Style in Material Balance Formulation	63
4.4	Checking the Material Balance for Accuracy	69
4.5	Application – Desalting Water by Reverse Osmosis	70
4.6	Application – Drying Sludge with Warm Air	73
4.7	Application – Boiler Blowdown	75
4.8	Application – Water Conservation in Rinsing Operations	76
4.9	Application – Effluent Limits and Waste Load Allocation	82
4.10	Material Balance for Partitioning Between Air, Water, and Soil	84
4.11	Application: Partitioning to Pyrene in a Small Lake	88
4.12	Conclusion	90

SIMPLY CLEVER

ŠKODA



We will turn your CV into  
an opportunity of a lifetime



Do you like cars? Would you like to be a part of a successful brand?  
We will appreciate and reward both your enthusiasm and talent.  
Send us your CV. You will be surprised where it can take you.

Send us your CV on  
[www.employerforlife.com](http://www.employerforlife.com)



Click on the ad to read more

<b>5</b>	<b>Solving Systems of Equations</b>	<b>92</b>
5.1	The Design Problem	92
5.2	Design Degrees of Freedom	92
5.3	Design Variable Selection	94
5.4	Information Flow and Precedence Order	97
5.5	Iterative Solutions of Systems with Information Recycle	99
5.6	Systems with Physical Recycle of Material	101
5.7	Using the Structural Array to Organize Calculations	105
5.8	Computer-Aided Design	110
5.9	Conclusion	111
<b>6</b>	<b>Material Balance with Chemical Reactions</b>	<b>112</b>
6.1	The Design Problem	112
6.2	Material Balances with Chemical Reactions	112
6.3	Reaction Stoichiometry	114
6.4	Case Study – Chemical Precipitation of Metals	118
6.5	Empirical Stoichiometry in Wastewater Treatment	122
6.6	Case Study – Anaerobic Sludge Digestion	123
6.7	Case Study – Aerobic Wastewater Treatment	125
6.8	Hypothetical Case Study – Cutter Chemicals	128
6.9	Conclusion	139

I joined MITAS because  
I wanted **real responsibility**

The Graduate Programme  
for Engineers and Geoscientists  
[www.discovermitas.com](http://www.discovermitas.com)



**Month 16**

I was a construction  
supervisor in  
the North Sea  
advising and  
helping foremen  
solve problems

Real work  
International opportunities  
Three work placements



 **MAERSK**

7	<b>The Unsteady-State Material Balance</b>	<b>140</b>
7.1	The Design Problem	140
7.2	The Unsteady-State Material Balance	140
7.3	Unsteady-State Storage Systems	140
7.4	The Unsteady-State Material Balance – Batch Smoothing	145
7.5	Smoothing the Flow Rate	146
7.6	Smoothing Concentrations	147
7.7	Smoothing Mass Loads	148
7.8	Dynamic Response of Continuous Flow Reactors	150
7.9	Numerical Solutions	155
7.10	Case Study – Municipal Activated Sludge Process	158
7.11	Conclusion	160

**ie** business school

#1 EUROPEAN BUSINESS SCHOOL  
FINANCIAL TIMES 2013

#gobeyond

**MASTER IN MANAGEMENT**

**Because achieving your dreams is your greatest challenge.** IE Business School's Master in Management taught in English, Spanish or bilingually, trains young high performance professionals at the beginning of their career through an innovative and stimulating program that will help them reach their full potential.

- Choose your area of specialization.
- Customize your master through the different options offered.
- Global Immersion Weeks in locations such as London, Silicon Valley or Shanghai.

*Because you change, we change with you.*

www.ie.edu/master-management | mim.admissions@ie.edu |



<b>8</b>	<b>Water Conservation and Reuse</b>	<b>161</b>
8.1	The Design Problem	161
8.2	Industrial Water Cycle	162
8.3	Cooling Towers	163
8.4	Process Water Reuse	165
8.5	Water Reuse and Water Quality	167
8.6	Mass Exchange Operations	169
8.7	The Composite Mass-Concentration Curve	171
8.8	Conclusion	176
<b>9</b>	<b>Accounting for Energy</b>	<b>177</b>
9.1	The Design Problem	177
9.2	Conservation of Energy – The First Law of Thermodynamics	178
9.3	The Heat Trap – The Second Law of Thermodynamics	181
9.4	Energy Units	184
9.5	Arithmetic Equivalence of Energy Units	184
9.6	Energy Conversion Efficiency	187
9.7	Renewable Energy	189
9.8	Conclusion	192
<b>10</b>	<b>The Energy Balance and Enthalpy</b>	<b>193</b>
10.1	The Design Problem	193
10.2	Enthalpy	193
10.3	Specific Heat	194
10.4	Cooling Tower Energy Balance	200
10.5	Boiler Efficiency and Water Use	204
10.6	Conclusion	208
<b>11</b>	<b>Energy Conservative Design</b>	<b>209</b>
11.1	The Design Problem	209
11.2	Heat Exchangers	210
11.3	Heat Exchanger Networks (HENs)	214
11.4	Pinch Analysis for Heat Exchanger Network Design	218
11.5	Conclusion	218

<b>12</b>	<b>Combustion of Municipal Refuse and Biogas</b>	<b>219</b>
12.1	The Design Problem	219
12.2	Combustion Stoichiometry	219
12.3	Composition of Solid Waste	223
12.4	Heating Value of Waste Materials	224
12.5	Incineration of Solid Waste and Sludge	228
12.6	Energy Recovery from Landfill Gas	228
12.7	Energy Recovery from Anaerobic Sludge Digestion	234
12.8	Conclusion	237
<b>13</b>	<b>Thermal Incineration of Waste Gas</b>	<b>238</b>
13.1	The Design Problem	238
13.2	Safety – The Explosive Limits	238
13.3	Thermal Incineration	240
13.4	Catalytic Incineration of Waste Gases	241
13.5	Case Study – Recovery of Heat from Combustion of Waste Gases	242
13.6	Case Study – Energy Balance on a Regenerative Thermal Oxidizer	248
13.7	Conclusion	256
<b>14</b>	<b>Energy Consumption by Pumping</b>	<b>257</b>
14.1	Water and Energy	257
14.2	Pump Efficiency	257
14.3	The Pump Curve and Efficiency Curve	258
14.4	Power Requirements	261
14.5	Calculating Head Losses from <i>K</i> Values	263
14.6	Designing Pumping Systems to Minimize the Cost	266
14.7	Air Blowers and Compressors	272
14.8	Conclusion	279

15	<b>References</b>	<b>280</b>
16	<b>Appendix 1 – Atomic Numbers and Atomic Masses</b>	<b>289</b>
17	<b>Appendix 2 – Conversion Factors</b>	<b>291</b>
18	<b>Appendix 3 – Densities and Specific Weights</b>	<b>293</b>
19	<b>Appendix 4 – Heating Values</b>	<b>298</b>
20	<b>Appendix 5 – Enthalpy of Water and Steam</b>	<b>300</b>
	<b>Index</b>	<b>301</b>

# Preface

Engineering design is about the creation of artificial things that have desired properties by combining elements into a coherent whole. These ‘things’ must be analyzed to make the elements correctly fit together so the desired result is accomplished.

There is little hope of an effective solution until the designer knows the amounts of material and energy moving through the system. Many of the systems we analyze exist only as alternatives in our mind, or on paper. We cannot measure that which does not yet exist and, still, we must have accurate estimates of the flow rates and compositions in order to assess and weigh the proposals that stand a chance of implementation. Skill in deducing the changes enables the necessary flow and composition data to be inferred.

The two fundamental tools for making the process analysis are the material balance and the energy balance. A material balance will be needed for virtually every pollution prevention and control problem. The material balance *and* the energy balance are needed when accounting for the use and flow of energy. All mass and energy entering the system must be accounted for. The inputs, of both mass and energy, must equal the outputs plus any accumulation within the system

This book explains how to calculate the material balance and the energy balance. Twenty five case studies and 85 examples explain how these tools are used. The examples include a variety of air, wastewater, and solid waste management problems and the student will learn a good deal about these areas of engineering while mastering the design tools. They will also be introduced to some fundamental concepts for chemical and biological reactions, material separations, and economic evaluations. Instructors can expand the learning experience by taking a minute or two to explain the context of the problem.

Pollution control engineers bring logic and order and solid quantitative information to the discussion about how public and private funds will be used to solve problems so better decisions will be made. Implementing the proposed solution goes beyond engineering design into public policy and business management so the overall result will be better if the people in these related areas understand some basic tools of the engineer.

The concepts and calculations in this book are accessible to students in non-engineering disciplines. Chapters 1–4, 6, 9 and 10 will make a useful short course for non-engineers, and also a strong introductory course or a supplement to conventional introductory courses in environmental engineering.

This is the second of five books on Pollution Prevention and Control. The first, *Pollution Prevention and Control: Human Health and Environmental Quality*, was about the general strategy of design, natural environmental cycles, toxicity and risk assessment for the protection of human and environmental health, the fate of pollutants in the environment, and a review of U.S. and international laws and regulations.



The books to follow will deal with:

- Using chemical and biological reactions to destroy and transform pollutants to facilitate the separation of different materials, or to make substances safe for discharge to water, air or soil.
- Systems to separate solids from liquids, solids from gases, solids from solids, and so on in all combination. The solution of a problem is never stymied by lack of separation technology, but it may be weakened by failure to organize them into efficient processing systems, or to overlook an innovative combination of transformation and separation.
- Minimizing costs and comparing alternate designs. Engineering projects almost always have more than one feasible solution, and often there are several that are attractive. The options must be measured and compared by using objective criteria like construction cost, lifetime cost, or mass of pollutant discharged. Also discussed are methods for evaluating non-monetary aspects of projects.

The goal of the series is to build problem-solving strategies and skills that are widely useful in water pollution control, air pollution control, and solid waste control. We want to stimulate innovation in pollution control systems design and pollution prevention.

The ultimate goal of environmental engineering, and the part of it that we call pollution control engineering, is to increase the level of health and happiness in the world. We hope this series of books will help to do that.

Shyi Tien Chen, National Kaohsiung First University of Science and Technology, Taiwan, and Mark Milke, University of Canterbury, New Zealand, reviewed a very early version and helped keep the project alive. Special thanks go to Dale Rudd (UW-Madison, Department of Chemical Engineering) for his support and ideas over many years. Also to our colleagues, Emeritus Professors William C. Boyle and Erhard Joeres, of the University of Wisconsin-Madison, Department of Civil & Environmental Engineering) for reviewing and improving the book.

Paul Mac Berthouex  
Emeritus Professor, Department of Civil and Environmental Engineering  
The University of Wisconsin-Madison

Linfield C. Brown  
Emeritus Professor, Department of Civil and Environmental Engineering  
Tufts University

May 2014

# 1 The Fundamentals of Design

## 1.1 The Design Problem

Science teaches about natural things and how they work. Engineering is about how artificial things are designed and constructed to serve some useful purpose.

Engineering design is a blend of *synthesis* and *analysis*. “*Synthesis* deals with the creation of artificial things that have desired properties by combining often diverse elements into a coherent whole. *Analysis* examines the elements and their relations. Each synthesis creates an analysis problem, the solution of which often provides insights that create a new synthesis (Rudd et al 1973).”

The basic elements that are organized into pollution prevention and control systems are

- *Reactors* in which chemical and biochemical reactions are promoted and controlled so that toxic, offensive, unstable, or low value materials can be transformed into non-toxic, inoffensive, stable, and useful materials.
- *Separation processes* that will concentrate or upgrade a material by selectively removing one species of material from another (solids from a liquid, for example).

Process synthesis cannot be studied without learning about transformations and separations, which are the subjects of other books. Analysis can be understood and practiced without knowing about the machinery that is used to accomplish the transformations and separations. We only need to know what change is accomplished or required.

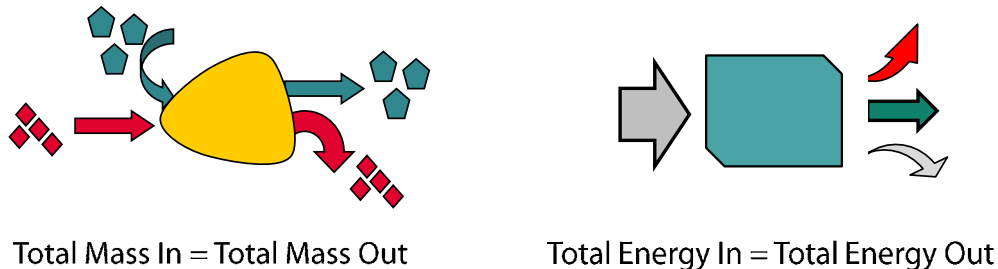
## 1.2 The Fundamental Concepts

There is little hope of an effective solution until the designer knows the amounts of material and energy that will be managed. In an existing system one might install meters, gauges, and instruments to measure flow rates and chemical composition. Information can be tallied from production records, waste shipping manifests, and product specifications.

But this will not provide all the needed information for two reasons, one technical and one philosophical.

The technical reason is that some quantities are not immediately available and can be obtained only by deductive reasoning from fragmentary available data. Certain kinds of effluents cannot be detected without extreme expenditures of time and money, if at all. Sometimes we cannot afford the luxury of making measurements, especially if the same information can be generated by scientific inference.

The philosophical reason is that we are concerned not only with the way things are but with the way things ought to be. Many of the systems we analyze exist only as alternatives in our mind, or on paper. We cannot measure that which does not yet exist but, we must have accurate estimates of the flow rates and compositions in order to assess alternate designs. This is done by using the two fundamental concepts shown in Figure 1.1.



**Figure 1.1** The fundamental principles: Conservation of Mass and Conservation of Energy

*Conservation of Mass* – Mass is neither created nor destroyed. All material flowing into and out of a system must be accounted for.

*Conservation of Energy* – Energy is neither created nor destroyed. All energy flowing into and out of a system must be accounted for.

The two most important design tools – the material balance and the energy balance – derive from these principles.

Large chunks of material and molecules can be changed within the system. Water becomes steam, steam becomes water, fuel becomes gas, particles dissolve, solutes precipitate, gases are absorbed by or stripped from liquids, and so on. Molecules are decomposed and the atoms are rearranged to make molecules of new materials. Whatever happens within the system, the mass that enters either leaves or is stored within the system.

The same is true for energy. Energy can be dissipated from a useful form into waste heat by friction or heat loss from steam pipes. Heat energy can become mechanical energy as when steam is used to drive a generator shaft. Mechanical energy can become kinetic energy as when a pump imparts motion to a fluid. After nature has done all the manipulations the total amount of energy must be the same. Some careful analysis may be needed to account for everything, but the Second Law of Thermodynamics says that the account must balance.

The concepts are easy to understand and the calculations are readily learned. In practice the more difficult work is estimating or collecting the necessary information about the flow and composition of the input and output streams.

### 1.3 The Material Balance and the Energy Balance

A material balance will be needed for virtually every pollution prevention and control problem. The material balance *and* the energy balance are needed when accounting for the use and flow of energy.

The material balance is used to answer such questions as:

- How will the amount of chemical sludge change if different chemicals are used to remove turbidity from river water?
- How much disinfectant per month must be purchased in order to achieve a specified disinfectant concentration in drinking water?
- How should the biological solids in a wastewater treatment plant be managed to yield a high quality effluent?
- How much useful (combustible) biogas will be produced in a landfill?
- How much sewage sludge must be blended with the solid refuse of a city to produce useful compost?
- How much sulfur dioxide will be emitted in the stack gas of a power plant per ton of coal burned?
- How much wastewater and sludge will be created by using lime slurry to scrub sulfur dioxide from stack gas?
- How much water is needed to rinse and clean parts in metal plating?
- Will waste chloride discharged from a proposed industry exceed what is tolerable in a river?

The energy balance is used to answer such questions as:

- How much heat energy can be obtained from biogas that is extracted from a landfill?
- How much heat energy can be recovered from the hot exhaust of a gas engine?
- Does a sludge digester produce enough biogas to heat the sludge that enters the digester?
- How much steam and cooling water can be saved by increasing the efficiency of a heat exchanger network?
- How much air must be supplied to an incinerator for efficient combustion of a waste gas?
- How much power is needed to supply air for activated sludge treatment of wastewater?

A variety of 85 example problems and 25 case studies will analyze problems such as these.

### 1.4 Block Diagrams

A variety of drawings are used from conception to final design of a project. To begin, when the process is mostly still in our imagination, *block diagrams* are used to show the process components and the flow of material and/or energy between them.



There are four basic process components: *mixers*, *splitters*, *reactors*, and *separators*. The reactors that transform materials are almost always integrated with processes that do separations. Mixers and splitters facilitate the process integration.

Figure 1.2 shows the inputs and outputs of the basic components for a simple process for removing lead from wastewater by adding lime to form a precipitate that is removed by filtration.

Figure 1.3 shows the components organized as a block diagram. A process block diagram provides no detail about the internal workings of the processes, but it does organize the information needed to do the material balance.

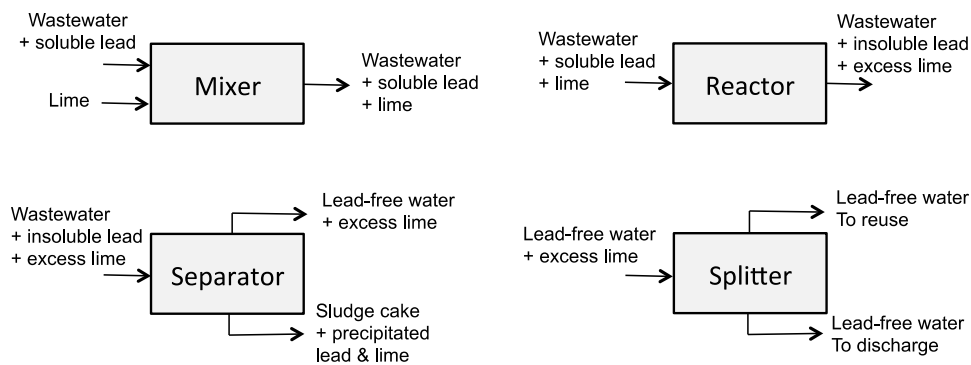


Figure 1.2 Diagrams of the four basic process components



## STUDY AT A TOP RANKED INTERNATIONAL BUSINESS SCHOOL

Reach your full potential at the Stockholm School of Economics, in one of the most innovative cities in the world. The School is ranked by the Financial Times as the number one business school in the Nordic and Baltic countries.

Visit us at [www.hhs.se](http://www.hhs.se)





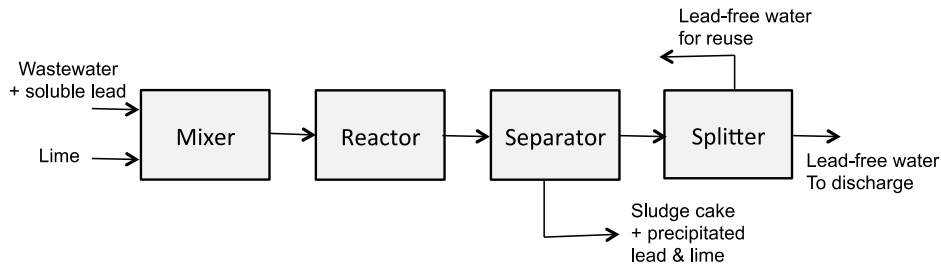


Figure 1.3 Process block diagram or flow sheet for a hypothetical lead removal process.

How is the block diagram constructed? The lead in the influent wastewater is soluble and the treatment concept is to convert dissolved lead into particles that can be removed by some kind of physical separation process, such as settling or filtration. The block diagram does not show the ultimate disposition of the particles that are removed as sludge. The effluent from the separator is safe for disposal to the environment and it is of sufficiently good quality to be reused in the manufacturing process.

### 1.5 Block Diagrams and the Material Balance

Figure 1.4 shows how the block diagram is used to organize the material balance. The block diagram shows a three-stage solid-liquid separation sequence and the mass of water and solids entering and leaving each stage. At each stage, the mass of water in equals the mass of water out. The same is true for the solids and for the total mass (water + solids). The influent solids concentration is 2% (2 T/100 T) and the solids leave the centrifuge at a 25% concentration (2 T/8 T). Three stages are used because each separation process is restricted on the solids concentration it can accept as feed and how much thickening it can do.

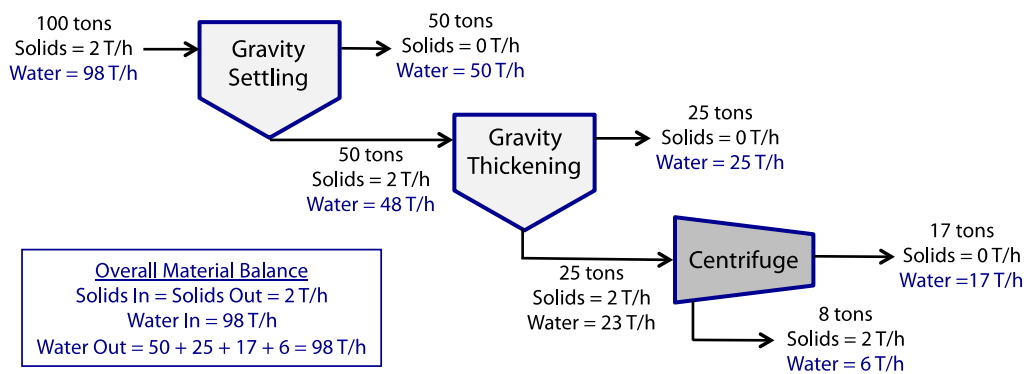


Figure 1.4 Block diagram for a 3-stage solid-liquid separation process to remove and concentrate solids. The mass of water that enters each stage equals the amount of water that leaves. The same is true for the solids and for the total mass (water + solids).

### 1.6 Inventing the Block Diagram

If the influent contains a mixture of materials that must be removed, the number of processing options increases and several alternatives may be evaluated to find the most cost effective.

Materials can be separated if they differ in some way and we can devise machinery to exploit that difference. Here is a simple example for separating a mixture of four dry materials that differ in size and solubility in water, as shown in the ordered property lists in Figure 1.5(a). One separation process will split one of the property lists into two parts.

Making the first separation using solubility will yield a solution that contains A and D, and another solution that contains B and C and the further separations will be difficult. Clearly the first separation must exploit the difference in size. Figure 1.5(b) and (c) shows two feasible processing schemes based on splitting the raw material according to size. (The inventive student will find one more feasible method of separating the four materials.) The processing shown in Figure 1.5(b) is easier because the size difference is larger than the 0.5 cm difference between D and the other solids.

Additional processing may be desirable. For example, the moisture may need to be removed from material A. Or, material C, which was dissolved to remove it from A, may need to be recovered as a solid which might lead to some kind of precipitation or drying process.

Another possibility is to look for a third property that will differentiate A and C, such as magnetic attraction or color difference.

Inventing block diagrams for processes is an inventor's playground.



#1  
in eco-friendly  
attitude

**STUDY AT  
LINKÖPING UNIVERSITY, SWEDEN**  
RANKED AMONG TOP 50 UNIVERSITIES UNDER 50

Interested in Strategy and Management in International Organisations? Kick-start your career with a master's degree from Linköping University, Sweden.

→ **Click here!**

 **Linköping University**

Analyzing the flow of material through the proposed systems is work for someone who knows how to calculate the material balance.

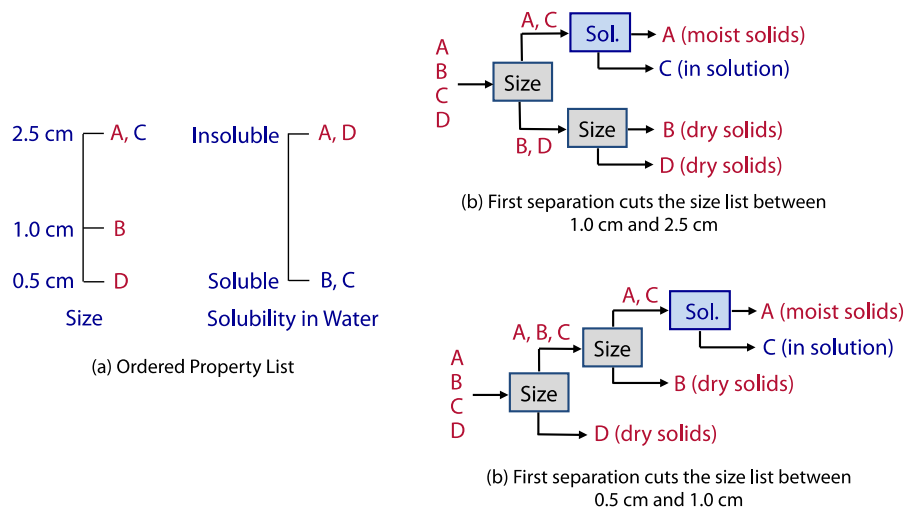


Figure 1.5 Invention of separation schemes by cutting ordered property lists.

## 1.7 Process Flow Diagrams

As details emerge the block diagram becomes a *process flow diagram*, or *process flow sheet*. Figure 1.6 is a flow diagram of the sort that is useful in brochures for visitors to a facility. It shows all process equipment connected into a complete system. Equipment used to move the material (pumps, etc.) and to heat and cool materials are shown. The convention is that material enters on the left and leaves on the right and, generally, gas streams are at the top, liquid streams are in the middle, and solid streams are at the bottom. Details like flow or quantity, composition, and temperature are indicated, usually in an accompanying table.

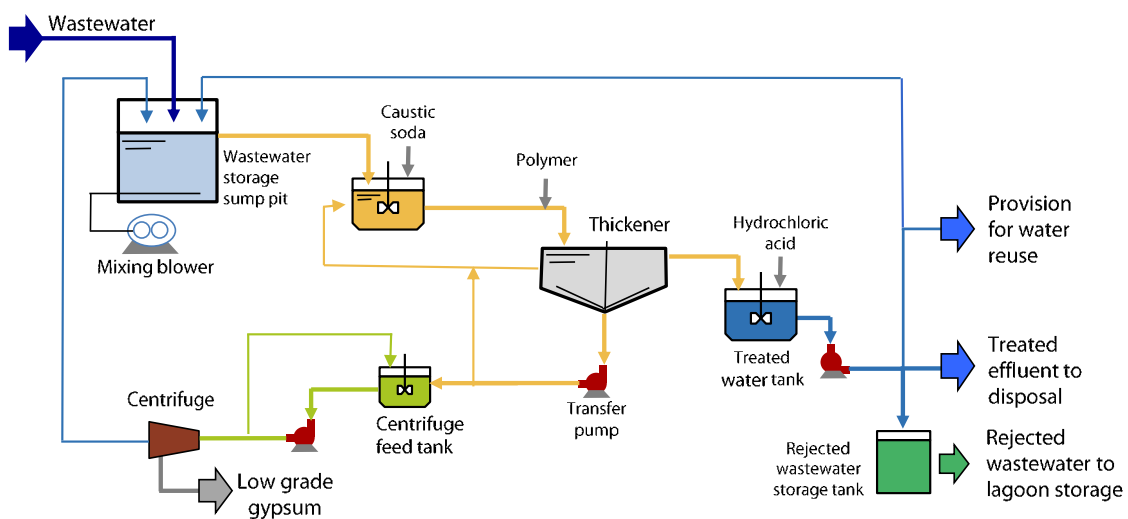


Figure 1.6 Process flow diagram without the details that are shown on the engineering process flow diagram.



## 1.8 Design Drawings and Specifications

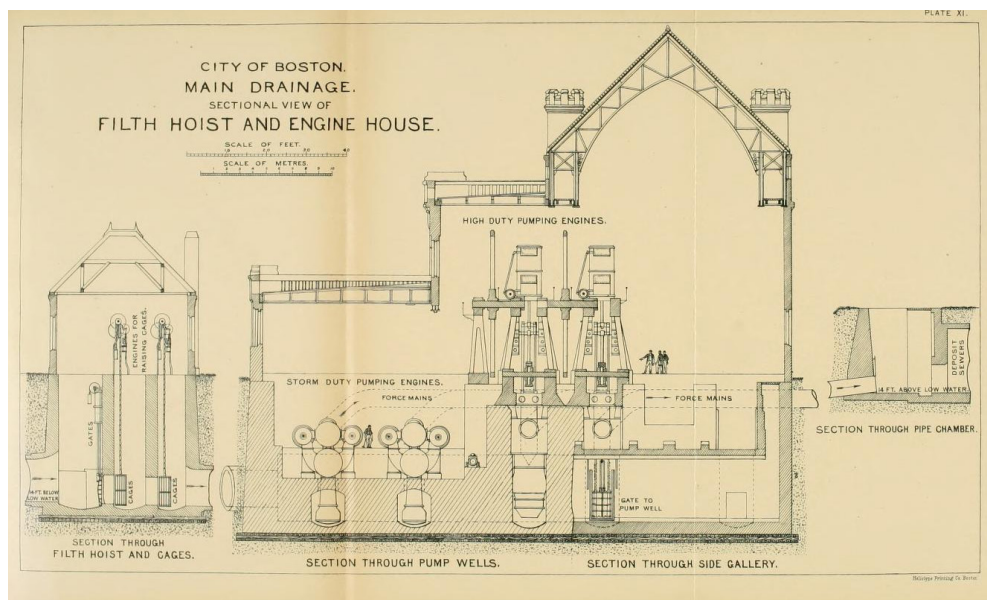
Figure 1.7 represents the large collection of detailed drawings needed for construction. These are scale drawings that give all dimensions, elevations, and a multitude of other details. Preparing these detailed drawings is time consuming and costly. The designer always estimates the number of pages of drawings that will be needed and this estimate is a keystone in setting the design fee.



**Figure 1.7** A collection of engineering drawings is needed to describe a project.

A book of technical specifications for material type and quality and the performance of mechanicals is provided with the drawings.

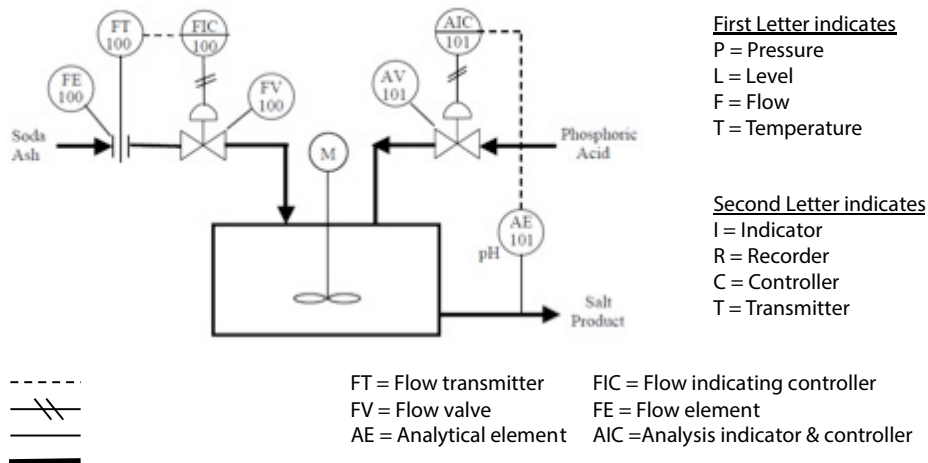
Figure 1.8 is a historical design drawing from a Boston sewer project that was built in the 1870s and 1880s. Sewage flowed by gravity to the Calf Pasture Pumping Station from where it was pumped away from the original harbor outfalls to Moon Island in Boston Harbor. Six tons of coal per day was burned to provide steam to drive the two Leavitt pumps that could each produce a 35-foot (11 m) lift for 25 million gallons (95,000 m<sup>3</sup>/d) of sewage per day. Coal was delivered by ship.



**Figure 1.8** Historic design drawing: Side view of the Calf Pasture Pumping Station in Boston (Clarke 1888)

## 1.9 Process and Instrumentation Diagrams

The process flow diagram shows less information than a *piping and instrumentation diagram* (P&ID). Figure 1.9 is a simple P&ID. There are two control loops. Loop 100 is for metering soda ash and loop 101 is for pH control by the addition of phosphoric acid. There is a standard system for lines, icons for valves and other elements, and nomenclature for tag names. All tag names in a loop have the same number. Tag names usually have two or more letters. The first letter indicates what is being measured, transmitted or controlled. The second letter indicates the function of the mechanical or electrical device.



**Figure 1.9** A P & ID showing two control loops. Loop 100 controls the addition of soda ash to the reactor and loop 101 controls the addition of phosphoric acid to a mixed reactor. Phosphoric acid is used to control the pH. FE is a flow element to measure the incoming flow and AE is an analytical element to measure pH.

## 1.10 Structure of this Book

The book has fourteen chapters. Chapter 2 is about pollutants and the units used to quantify concentrations and masses. Chapter 3 is a collection of case studies that illustrate what is meant by pollution prevention and what can be accomplished once the flow of materials through a system is known.

Chapters 4 and 5 explain how material balance problems are formulated and solved. There are examples from all areas of pollution prevention and control. Chapter 6 teaches how to make the material balance when there are chemical reactions. Chapter 7 deals with unsteady-state material balances for processes in which volumetric and mass flow rates vary over time. Chapter 8 is about using the material balance for water conservation and reuse.

Chapters 9 to 10 are about energy balance problems, starting with the units that are used to quantify energy flow and how the energy balance is made using a property known as enthalpy, which is analogous to mass in the material balance. Chapters 11, 12 and 13 deal with the efficient use of energy and with the use of waste materials, including biogas, as fuels. Chapter 14 is about the design of pumping and air blower systems, which account for nearly all the energy use in a wastewater treatment plant.

The essential chapters are 1–4, 6, 9 and 10. These give the fundamental concepts and many example calculations. The other chapters add detail and add many examples and case studies.

## 1.11 Conclusion

This has been an overview of the design process, from the initial concepts that are sketched out in block diagrams (some designers call these cartoons) through to the detailed final design.

The analysis of material and energy flow in this book will be done with block diagrams and simplified process flow diagrams.

Cost estimates are needed in preliminary design to assess financial feasibility and to compare different ideas. More detailed designs with more accurate cost estimates are needed later for client consultations. Finally, detailed designs and cost estimates are needed to arrange budgets and financing. The accuracy of these estimates may be  $\pm 25\%$  at the preliminary stage and  $\pm 5\%$  for the detailed design.

Our interest lies in the early stages of design. These are the most creative and they offer the best possibilities to be innovative with pollution prevention and pollution control. The information that is available for making preliminary cost estimates comes entirely from process flow diagrams and material and energy balances. These are the fundamental tools and the focus of the next few chapters.



"I studied English for 16 years but...  
...I finally learned to speak it in just six lessons"  
Jane, Chinese architect

ENGLISH OUT THERE

Click to hear me talking before and after my unique course download

## 2 Measures of Pollution

### 2.1 The Problem

Pollutants come in many physical and chemical forms, and almost always as a mixture. There will be dissolved chemicals in water, particles in liquids and gases, solids mixed with other solids, and gases mixed with air. The pollutants need to be identified and quantified as the first step in defining the problem. Then concentrations, volume flow rates, and mass flow rates are needed to solve the problem.

This chapter reviews common units that are used to measure concentration, volume, mass, and flow rate. It will also define some measures of pollution.

### 2.2 Pollutants

#### 2.2.1 Classes of Pollutants

Toxic and hazardous chemicals, such as benzene, copper and other heavy metals, pesticides, and other organic chemicals, are specifically identified and given limits in the regulations. These must be measured individually as specific chemicals.

‘Lumped’ characteristics are commonly used for solids and organics in wastewater, including particulate matter (PM), suspended solids (SS), total dissolved solids (TDS), and chemical oxygen demand (COD). In water the particles may be organic or inorganic, biological (bacteria and algae), or chemical.

Particulate matter (PM) in air measures the total concentration or total mass and does not differentiate the kinds of solids, such as metal fumes, fly ash, dust or pollen in air.

#### 2.2.2 Solids in Water and Wastewater

Solids in water and wastewater are measured as mass per volume, usually mg/L. In many applications it is sufficient to use ‘lumped’ or aggregate measures, such as total solids, total volatile solids (organic solids), and total fixed solids (inert solids). These measures give no information about composition of the individual solid particles. Specific dissolved ions and dissolved organic compounds are unknown.

*Total solids* is the residue left in a vessel after the sample has been dried to a constant weight at 103-105°C. Total solids includes particles and dissolved materials. *Volatile solids* is measured as the mass of material that will burn off at 550°C. *Fixed solids* are whatever will not burn at a temperature of 550°C; fixed solids are the ash (APHA 1992).

*Volatile solids* is an aggregate measure of all the organic matter in a sample. All carbohydrates, fats, proteins, and synthetic chemicals will be measured as volatile solids. When a biological treatment process reduces the mass of total solids, the lost mass is volatile solids that have been converted to gas (usually methane or carbon dioxide). If the volatile solids decrease and fixed solids increase it is because organic compounds have been mineralized.

*Suspended solids* are particles that can be captured on a filter of 2.0  $\mu\text{m}$  (or smaller) pore size. '*Dissolved solids*' pass through the filter. More correctly these are called *filterable solids* because this fraction includes very small particles (*colloids*) as well as truly dissolved chemicals. Dissolved solids could be measured by using filters with a finer pore size, or by using an ultra-centrifuge to remove the particles. The distinction between filterable solids and dissolved solids is unimportant in most applications and we will use dissolved solids.

The relations are

$$\text{Total solids (TS)} = \text{Volatile solids (VS)} + \text{Fixed solids (FS)}$$

$$\text{Total solids (TS)} = \text{Total suspended solids (TSS)} + \text{Total dissolved solids (TDS)}$$

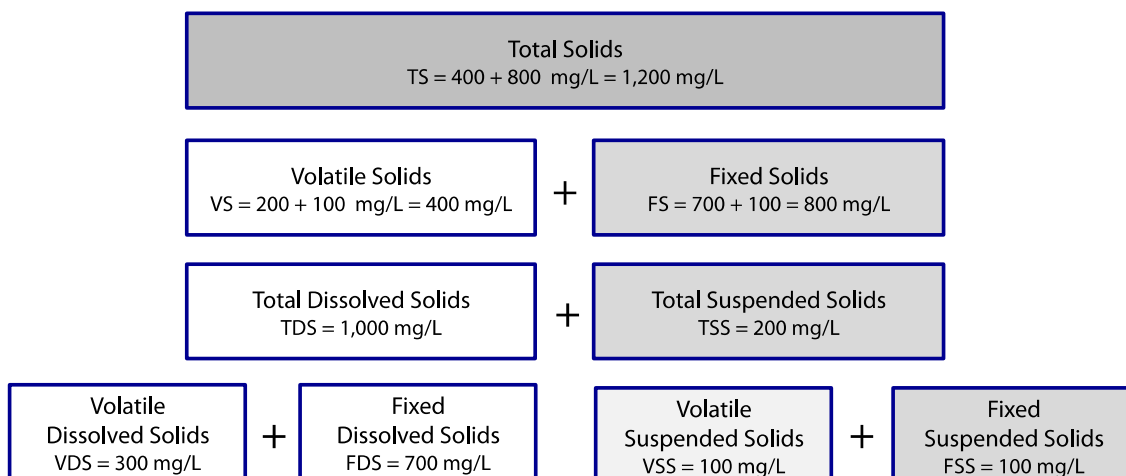
$$\text{Total suspended solids (TSS)} = \text{Volatile suspended solids (VSS)} + \text{Fixed suspended solids (FSS)}$$

$$\text{Total dissolved solids (TDS)} = \text{Volatile dissolved solids (VDS)} + \text{Fixed dissolved solids (FDS)}$$

**Example 2.1** RELATIONS OF SOLIDS IN WATER AND WASTEWATER

Figure 2.1 shows a possible distribution of solids in wastewater, but not necessarily a typical distribution. The objective is to define the classes of solids that are commonly measured to characterize wastewater.

$$\begin{aligned} \text{TDS} &= \text{VDS} + \text{FDS} = 300 \text{ mg/L} + 700 \text{ mg/L} = 1,000 \text{ mg/L} \\ \text{TSS} &= \text{VSS} + \text{FSS} = 100 \text{ mg/L} + 100 \text{ mg/L} = 200 \text{ mg/L} \\ \text{FS} &= \text{FDS} + \text{FSS} = 700 \text{ mg/L} + 100 \text{ mg/L} = 800 \text{ mg/L} \\ \text{VS} &= \text{VDS} + \text{VSS} = 300 \text{ mg/L} + 100 \text{ mg/L} = 400 \text{ mg/L} \\ \text{TS} &= \text{VS} + \text{FS} = 400 \text{ mg/L} + 800 \text{ mg/L} = 1,200 \text{ mg/L} \end{aligned}$$



**Figure 2.1** The relations of the different classes of solids that are commonly used to characterize wastewater.



### 2.2.3 Biochemical Oxygen Demand (BOD)

There are no specific limits for carbohydrates, fats and proteins, or for the individual kinds of carbohydrates (glucose, starch, etc.) or for proteins and their amino acid building blocks (glycine, tryptophan, etc.). There are regulations for aggregates of these kinds of organic chemicals. What they have in common is that they can be decomposed and metabolized by bacteria and other microbes. Almost all wastewater treatment plants include processes to accomplish this biodegradation under controlled conditions.

Biochemical Oxygen Demand (BOD) is a measure of the oxygen consuming activity of aerobic (i.e., oxygen consuming) microorganisms. Oxygen consumption is proportional to the amount biodegradable organic compounds that are metabolized by the organisms as they consume the oxygen.

Every wastewater treatment plant has an effluent limit for BOD, which may range from 5 mg/L to 30 mg/L (in the U.S.). Whatever portion of influent BOD that is not eliminated in the treatment process can be exerted in a lake or stream, thus reducing the dissolved oxygen that is needed for a healthy aquatic population.

Excellent Economics and Business programmes at:



university of  
 groningen



“The perfect start  
 of a successful,  
 international career.”

**CLICK HERE**  
 to discover why both socially  
 and academically the University  
 of Groningen is one of the best  
 places for a student to be

[www.rug.nl/feb/education](http://www.rug.nl/feb/education)

The 5-day BOD test is a bioassay that is done in sealed bottles (BOD bottles) that contain diluted wastewater. The dilution water-wastewater mixture is aerated to give an initial dissolved oxygen (DO) concentration close to 9 mg/L. (The saturation concentration of oxygen in clean water is 9.18 mg/L at 20°C). The samples are incubated at a standard temperature of 20°C for 5 days to measure the 5-day BOD, or  $BOD_5$ . The dissolved oxygen concentration is measured after 5 days of incubation at a standard temperature of 20°C.

The DO depletion ( $\Delta DO_{bottle}$ ) from the initial to the final concentration is proportional to the amount of biodegradable organic matter in the sample. The BOD of the *bottle contents* is

$$BOD_{bottle} = \Delta DO_{bottle} = [initial\ DO] - [final\ DO]$$

The final DO must be 2 mg/L or greater for the measurement to be valid. The DO depletion in the bottle must be less than 6-7 mg/L. This requirement is the reason for incubating a diluted mixture.

The dilution factor ( $DF$ ) is the ratio of the BOD bottle volume to the volume of wastewater in the bottle.  $DF = (V_{bottle})/(V_{sample})$ .  $DF = 30$  means a 10 mL wastewater volume in a 300 mL bottle;  $DF = 300/10$ .  $DF = 2$  means that the incubated mixture is 50% effluent and 50% dilution water:  $DF = 300/150$ .

The BOD of the undiluted wastewater is

$$BOD_{waste} = (DO\ depletion) \left( \frac{V_{bottle}}{V_{sample}} \right) = (\Delta DO)(DF)$$

The effluent from a well-operated modern activated sludge process will be less than 10 mg/L  $BOD_5$ . A dilution factor of 2 should be suitable. A  $BOD_5$  concentration of 200 mg/L to 300 mg/L is typical for municipal wastewater. A dilution factor ( $DF$ ) of 25–50 is needed so the mixture has  $BOD_{bottle} \leq 6-7$  mg/L.

A longer incubation time of 20 to 30 days is used to measure the *ultimate BOD*. The *ultimate BOD* is proportional to the quantity of biodegradable organic compounds that were present at the start of the incubation period. The 5-day BOD is approximately two-thirds of the ultimate BOD for municipal wastewater.

The BOD test is problematic in many ways, aside from taking 5-days to get a result. One problem, because it is a bioassay, is toxicity, especially with some industrial wastewaters. COD can be used as a surrogate for biodegradable organics in wastewater even though it will measure some compounds that are not biodegradable.



**Example 2.2 MEASURING BOD**

Four 300 mL BOD bottles (see Figure 2.2) are used to measure the 5-day BOD of a municipal wastewater. The test conditions are given in Table 2.1. Three of the four dilutions (bottles) give valid test results. These are averaged to estimate the 5-day BOD of 297 mg/L, which is rounded to 300 mg/L.

Bottle ID No.	Volume of wastewater V (mL)	Dilution Factor $DF = 300/V$	Initial DO (mg/L)	Final DO (day 5) (mg/L)	DO depletion $\Delta DO$ (mg/L)	5-day BOD = $DF \cdot \Delta DO$ (mg/L)
8	2	150	9.1	7.3	1.8	270
15	4	75	9.1	5.1	4	300
18	6	50	8.9	2.5	6.4	320
21	10	30	9	$1.8 \leq 2.0$	invalid	invalid

**Table 2.1** 5-day BOD test data



**Figure 2.2** A rack of bottles used for measuring the Biochemical Oxygen Demand (BOD)

### 2.2.4 Chemical Oxygen Demand (COD)

*Chemical Oxygen Demand* (COD) is another “lumped” or aggregate measure of organics. BOD measures oxidation by bacteria under aerobic conditions. This is the mechanism that robs streams of oxygen when they are polluted with organic wastes. BOD is what we want to know. The COD is an estimate of the ultimate BOD. COD is always larger than the ultimate BOD, which is always larger than the  $BOD_5$ .

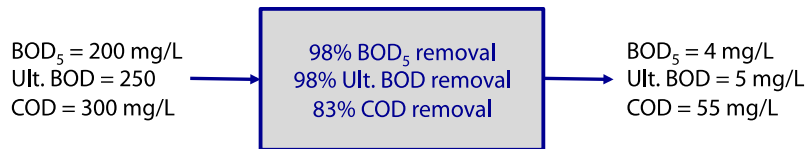
The COD test measures all organic compounds that can be oxidized to carbon dioxide with a strong chemical oxidizing agent (dichromate) under acidic conditions. This includes all carbohydrates, fats and proteins and most synthetic organic compounds. It can be measured on the whole wastewater or on the ‘soluble’ (filterable) fraction of a wastewater.

The COD test has two advantages. It can be completed in a few hours, compared to 5 days for the  $BOD_5$  test. It can be measured on wastewaters that are toxic to the bacteria on which the BOD test depends. This makes it useful for certain kinds of industrial wastewaters.

**Example 2.3 MEASURES OF BIODEGRADABLE ORGANICS IN WASTEWATER**

The influent to a biological wastewater treatment process (e.g. an activated sludge process) contains 250 mg/L ultimate BOD and 300 mg/L COD (total oxidizable organics). The treatment removes 245 mg/L ultimate BOD so the effluent contains 5 mg/L ultimate BOD. The treatment will also remove 245 mg/L COD (the same compounds that make up the ultimate BOD) and the effluent COD is 55 mg/L. The non-biodegradable COD in the influent passes through to the effluent untouched by microbial action.

The influent and effluent BOD<sub>5</sub> are 80% of the ultimate BOD.



**Figure 2.3** Removal of biodegradable organics from wastewater.

## 2.3 Units

Material quantities, flow rates, and concentrations are expressed in a variety of units. It is most convenient to work entirely in SI units (liters, kilograms, and meters). Gallons, pounds, and feet are still used widely in the U.S., as they were once in the UK and some other countries. Converting units is a nuisance, but many engineers sooner or later will be retrofitting an old design that used these units. Therefore, some knowledge of both systems of units is a useful complement to one's skill set.

In the past four years we have drilled  
**89,000 km**  
That's more than **twice** around the world.

**Who are we?**  
We are the world's largest oilfield services company<sup>1</sup>. Working globally—often in remote and challenging locations—we invent, design, engineer, and apply technology to help our customers find and produce oil and gas safely.

**Who are we looking for?**  
Every year, we need thousands of graduates to begin dynamic careers in the following domains:

- Engineering, Research and Operations
- Geoscience and Petrotechnical
- Commercial and Business

**What will you be?**

**Schlumberger**

careers.slb.com

<sup>1</sup>Based on Fortune 500 ranking 2011. Copyright © 2015 Schlumberger. All rights reserved.



Tables 2.2 and 2.3 give the most common units used in material balances. Volumetric flow rate is measured as liters per hour, cubic meters per second, gallons per hour, and so on. Temperature and pressure, within ordinary limits, have a negligible effect on the volume of liquids.

Air and other gases expand and contract with changes in temperature and pressure and volume must be reported either at standard conditions or at the actual temperature and pressure of the gas.

Quantity	Units	Comments & Conversion Factors
Density	g/L, kg/m <sup>3</sup> lb/ft <sup>3</sup> , lb/gal	1 g/L = 1 kg/m <sup>3</sup> 1 lb = 453.6 g; 1 kg/m <sup>3</sup> = 0.06243 lb/ft <sup>3</sup>
Volume	cm <sup>3</sup> , liter, m <sup>3</sup> ft <sup>3</sup> , gal (US)	1 m <sup>3</sup> = 1000 L 1 m <sup>3</sup> = 35.31 ft <sup>3</sup> ; 1 L = 0.2642 gal (US) = 0.2200 gal (UK)
Volume Flow Rate	m <sup>3</sup> /s, L/s ft <sup>3</sup> /s, gal/h, gal/day, mgd acfm, scfm	1 m <sup>3</sup> /s = 35.31 ft <sup>3</sup> /s 1 m <sup>3</sup> /s = 35.31 ft <sup>3</sup> /s; mgd = million gal/day 1 m <sup>3</sup> /s = 15,850 gal/min (US) = 13,200 gal/min (UK) actual ft <sup>3</sup> /min, standard ft <sup>3</sup> /min; used in US for air flows 1 m <sup>3</sup> /s = 2119 ft <sup>3</sup> /min
Mass	μg, mg, g, kg, gm-mole, Tonne lb, lb-mol, ton	1 kg = 2.205 lb; 453.6 g = 1 lb; 1 Tonne (T) = 1000 kg 1 lb = 453.6 g, 1 ton = 2000 lb
Mass Flow Rate	g/min, kg/h, g-mol/h lb/h, lb/day, lb-mol/h	
Concentration	ppm, mg/kg ppb, μg/kg ppmv μg/L, mg/L  μg/m <sup>3</sup> , mg/m <sup>3</sup> weight percent volume percent mole fraction	parts per million by weight parts per billion by weight parts per million by volume; used in gaseous mixtures 1 mg/L = 1000 μg/L for liquids; may be used for gases if volume is referenced for temperature and pressure.  used for particulate concentrations in gases used for solid and liquid mixtures used for gaseous mixtures mole fraction = volumetric fraction in gaseous mixtures

**Table 2.2** Units commonly used to measure composition and flow rate.

Quantity	SI Units	SI Symbol	Conversion Factor	USCS Units
Length	meter	m	3.281	ft
Mass	kilogram	kg	2.205	lb
Flow Rate	cubic meter <sup>s</sup> per sec	m <sup>3</sup> /s	35.31	ft <sup>3</sup> /s
Area	square meter	m <sup>2</sup>	10.76	ft <sup>2</sup>
Volume	cubic meter	m <sup>3</sup>	35.31	ft <sup>3</sup>
Velocity	meter/sec	m/s	2.237	mi/h
Density	kilogram/meter <sup>3</sup>	kg/m <sup>3</sup>	0.06243	lb/ft <sup>3</sup>

**Table 2.3** Some basic units and conversion factors. (USCS = U.S. customary units)

Material flows are expressed in terms of mass per time, such as kilograms per hour (kg/h), kg-moles per hour (kg-mol/h), and lb/day. Mass flow is computed from the volumetric flow, density of the material, and the concentration of the pollutant in the material.

A mixture is described by giving the concentration of each species in the mixture. Concentration can be expressed as mass per unit mass, mass per unit volume, or volume per unit volume. In solids it is common to report concentration as mass per unit mass, for example mg of pollutant per kg of dry solid material. Note that 1 mg/kg is one part per million (ppm) on a dry mass basis. In solids and liquids, ppm is always a mass ratio. In a gas, ppm indicates one part in a million parts based on volume, and it should be identified by ppmv instead of simply as ppm.

## 2.4 Liquids, Sludge and Solids

Concentrations in liquids are given as mass per volume concentrations, such as grams per liter (g/L), milligrams per liter (mg/L), and micrograms per cubic meter ( $\mu\text{g}/\text{m}^3$ ). They may also be expressed as mass ratios, such as parts per million (ppm) or parts per billion (ppb).

When the specific gravity of the liquid is 1.000, mg/L and ppm are equivalent. One liter of solution weighs 1 kg = 1,000,000 mg and 1 mg pollutant in 1,000,000 mg of solution is the same as 1 mg pollutant in 1 liter of solution. Interchanging mg/L and ppm is acceptable for municipal sewage (which is 99.99% water), and for many industrial wastewaters, and dilute slurries of low-density solids. It should not be used for highly saline wastewater, sludge, soil, or sediments.

Concentrations of pollutants in dense slurries, sludge, sediments, soil, and other solids are given as mass ratios. It is important to make clear whether the mass of bulk material is on a dry or wet basis. A concentration of 1 mg/kg means 1 milligram of pollutant in 1 kilogram of dry material; 1  $\mu\text{g}/\text{kg}$  means 1 microgram of pollutant in 1 kilogram of dry material. Also, a concentration of 1 mg/kg means 1 part per million and 1  $\mu\text{g}/\text{kg}$  means 1 part per billion.

Concentration as a weight percent can be used for solids or liquids. To say that sludge is “4% solids by weight” means that 4% of the total sludge mass is solids. The total sludge mass includes the water and the solids. Thus, 4% solids by weight also means 96% water by weight. And it means 0.04 kg dry solids per kg of wet sludge.

### Example 2.4 SLUDGE VOLUME AND MASS

An industry is holding 8000 m<sup>3</sup> of dense industrial sludge that has specific gravity 1.3. Calculate the sludge mass.

- One cubic meter of water weighs 1000 kg
- One cubic meter of the sludge weighs 1300 kg
- Sludge mass = (8000 m<sup>3</sup>)(1300 kg/m<sup>3</sup>) = 10,400,000 kg = 10,400 metric tons

**Example 2.5 MERCURY IN WATER**

A wastewater effluent of 1000 liters per hour contains an average of 6  $\mu\text{g/L}$  mercury (Hg). Calculate the mass flow of mercury discharged per day (g/d).

- Volume of water =  $(1000 \text{ L/h})(24 \text{ h/d}) = 24,000 \text{ L/d}$
- Each liter contains 6  $\mu\text{g} = 0.006 \text{ mg} = 0.000,006 \text{ g Hg}$
- Mass of Hg discharged =  $(24,000 \text{ L/d})(6 \mu\text{g/L})(1 \text{ g}/1,000,000 \mu\text{g}) = 0.144 \text{ g Hg/d}$

**Example 2.6 CADMIUM IN SLUDGE**

How much cadmium, Cd, is added to a farm field if 20  $\text{m}^3$  of liquid sludge that is 6% solids (by weight) is incorporated into soil? The density of the liquid sludge is 1030  $\text{kg/m}^3$ . The measured concentration of cadmium in the sludge is 10 ppm, defined in terms of the dry sludge solids.

- 10 ppm = 10 mg Cd/1,000,000 mg dry sludge solids = 10 mg Cd/kg dry solids
- Dry solids in the sludge =  $(20 \text{ m}^3)(1030 \text{ kg/m}^3)(0.06) = 1236 \text{ kg}$
- Cd contained in the dry solids =  $(1236 \text{ kg dry solids})(10 \text{ mg Cd}/10^6 \text{ kg dry solids}) = 0.01236 \text{ kg}$

## American online LIGS University

is currently enrolling in the  
Interactive Online **BBA, MBA, MSc,**  
**DBA and PhD** programs:

- ▶ enroll **by September 30th, 2014** and
- ▶ **save up to 16%** on the tuition!
- ▶ pay in 10 installments / 2 years
- ▶ Interactive Online education
- ▶ visit [www.ligsuniversity.com](http://www.ligsuniversity.com) to find out more!

Note: LIGS University is not accredited by any nationally recognized accrediting agency listed by the US Secretary of Education. More info [here](#).



**Example 2.7 SOLIDS IN SLUDGE**

Sludge, a slurry of solids and water, is pumped from a wastewater sedimentation basin at specific gravity 1.03, total solids concentration 6%, and volumetric flow rate of 50 m<sup>3</sup>/d. Calculate the mass flow rate of the sludge and the dry solids.

- 1 m<sup>3</sup> of water has a mass of 1,000 kg
- 1 m<sup>3</sup> of sludge has a mass of 1.03(1000) = 1030 kg
- Mass flow rate of sludge pumped = (50 m<sup>3</sup>/d)(1030 kg/m<sup>3</sup>) = 51,500 kg/d
- Mass flow rate of dry sludge solids = (0.06)(51,500 kg/d) = 3090 kg/d

**Example 2.8 SAMPLING AN AIR DUCT**

A rectangular air duct has a total area of 3.2 m<sup>2</sup> that has been divided into four 0.8 m<sup>2</sup> sectors. Figure 2.4 shows the dust concentration (mg/m<sup>3</sup>) and the air velocity (m/s) data, which are at 20°C and 1 atm pressure. Calculate the total air flow rate and the mass emission rate for dust.

Dust = 0.11 mg/m <sup>3</sup> Velocity = 4 m/s	Dust = 0.16 mg/m <sup>3</sup> Velocity = 4.4 m/s
Dust = 0.13 mg/m <sup>3</sup> Velocity = 4.1 m/s	Dust = 0.15 mg/m <sup>3</sup> Velocity = 4.2 m/s

**Figure 2.4** Dust and velocity data

For the top left sector

- Air flow rate = (0.8 m<sup>2</sup>)(4 m/s) = 3.2 m<sup>3</sup>/s
- Mass flow rate of dust = (3.2 m<sup>3</sup>/s)(0.11 mg/m<sup>3</sup>) = 0.352 mg/s

$$\begin{aligned} \text{Total air flow} &= (0.8 \text{ m}^2)(4 \text{ m/s}) + (0.8 \text{ m}^2)(4.1 \text{ m/s}) + (0.8 \text{ m}^2)(4.4 \text{ m/s}) + (0.8 \text{ m}^2)(4.2 \text{ m/s}) \\ &= 3.2 \text{ m}^3/\text{s} + 3.28 \text{ m}^3/\text{s} + 3.52 \text{ m}^3/\text{s} + 3.36 \text{ m}^3/\text{s} = 13.36 \text{ m}^3/\text{s} \end{aligned}$$

Total mass flow of dust

$$\begin{aligned} &= (3.2 \text{ m}^3/\text{s})(0.11 \text{ mg/m}^3) + (3.28 \text{ m}^3/\text{s})(0.13 \text{ mg/m}^3) + (3.52 \text{ m}^3/\text{s})(0.16 \text{ mg/m}^3) + (3.36 \text{ m}^3/\text{s})(0.15 \text{ mg/m}^3) \\ &= 0.352 \text{ mg/s} + 0.4264 \text{ mg/s} + 0.5632 \text{ mg/s} + 0.504 \text{ mg/s} = 1.8456 \text{ mg/s} \end{aligned}$$

Note: Multiplying the average air flow rate and the average dust concentration will give the wrong answer.

- Average air flow = 3.34 m<sup>3</sup>/s
- Average dust concentration = 0.1375 mg/m<sup>3</sup>
- Mass flow of dust = 4(3.34)(0.1375) = 1.837 mg/s

**Example 2.9 ORGANIC WASTEWATER LOADING**

The influent to a wastewater treatment plant has a flow of 10 million gallons per day (mgd) and a 5-day BOD concentration of 250 mg/L. What is the organic load in units of pounds of BOD per day?

- Assume the wastewater specific gravity = 1.00
- Assume specific weight of wastewater = 8.34 lb/gal
- Mass flow of wastewater = (8.34 lb/gal)(10,000,000 gal/day) = 83,400,000 lb/day
- Mass flow of 5-day BOD

$$\text{Mass flow of BOD}_5 = \left( \frac{250 \text{ lb BOD}_5}{1,000,000 \text{ lb wastewater}} \right) \left( 83,400,000 \frac{\text{lb}}{\text{day}} \text{ wastewater} \right) = 20,850 \frac{\text{lb BOD}_5}{\text{day}}$$

- More directly

$$\text{Mass flow of BOD}_5 = (8.34)(10 \text{ mgd})(250 \text{ ppm}) = 20,850 \frac{\text{lb BOD}_5}{\text{day}}$$

## 2.5 Gases

### 2.5.1 The Ideal Gas Law

Gases expand as temperature is increased and compress as pressure is increased, so gas volume or volumetric flow rate have no useful meaning until the corresponding gas temperature and pressure are known.

The most used “standard conditions” are those of the International Union of Pure and Applied Chemistry (IUPAC) and the National Institute of Standards and Technology (NIST). Other organizations have adopted alternative definitions of standard conditions.

Normal cubic meters per hour (Nm<sup>3</sup>/h) is the volumetric flow rate for gases at 0°C and 1 atm (101.325 kPa).

In the U.S. a common measure is scfm to indicate ‘standard cubic feet per minute’ or acfm to indicate ‘actual cubic feet per minute’. The ‘standard’ refers to a reference condition known in chemistry and physics as standard temperature and pressure (STP). A similar reference condition in industrial hygiene and air pollution work is the normal condition (normal temperature and pressure, or NTP). Several widely used definitions for the reference, or “standard” conditions are given in Table 2.4.



Discipline	Temperature	Absolute Temp.	Pressure	Organization
Chemistry/physics (STP)	0°C	273.15 K	100.000 kPa, 0.987 atm	IUPAC
Chemistry/physics (STP)	20°C	293.15 K	101.325 kPa, 1 atm	NIST
Air pollution (new sources)	20°C	293.15 K	101.325 kPa, 1 atm	U.S. EPA
Air pollution (ambient air)	25°C	298.15 K	101.325 kPa, 1 atm	Air pollution
Industrial ventilation	21.1°C (70 °F)	529.67 °R	29.921 in Hg	
Industrial hygiene	60 °F	519.67 °R	14.696 psi	U.S. OSHA
ASHRAE*	15°C (59.0 °F)	288.15 K	101.325 kPa, 1atm	

\* ASHRAE = American Society for Heating Refrigeration and Air Conditioning

**Table 2.4** Standard conditions for various disciplines (dry air only). STP indicates standard temperature and pressure for basic science. NTP indicates normal temperature and pressure conditions used in the U.S. for industrial hygiene and air pollution. (Source: Wikipedia)

Gas concentrations are usually measured as a volumetric ratio, typically parts per million by volume, ppmv. The ppmv concentration is independent of changes in pressure and temperature because all gases in a mixture expand or contract to the same extent. For example, if the concentration of SO<sub>2</sub> in air is 15 ppmv, then every million volumes of air contains 15 volumes of SO<sub>2</sub> regardless of how the gas mixture is compressed or expanded. This is one advantage of using ppmv units for air pollution work.

.....Alcatel-Lucent 

[www.alcatel-lucent.com/careers](http://www.alcatel-lucent.com/careers)

What if you could build your future and create the future?

One generation's transformation is the next's status quo. In the near future, people may soon think it's strange that devices ever had to be "plugged in." To obtain that status, there needs to be "The Shift".

 [Click on the ad to read more](#)

A mass concentration, say  $\mu\text{g}/\text{m}^3$  or  $\text{mg}/\text{m}^3$ , is needed to make a material balance. The mass concentration is calculated using the molecular mass of the gaseous pollutant. Corrections for pressure and temperature may be required. These corrections are made using the ideal gas law:

$$PV = nRT$$

where  $P$  = pressure, atm

$T$  = absolute temperature, K

$V$  = gas volume, L

$n$  = number of moles of gas

$R$  = universal gas constant = 0.08205 L atm/mole K

The value of  $R$  depends on the units used for pressure, temperature, and volume, as given in Table 2.5.

<b>R value and units</b>	<b>Pressure</b>	<b>Temperature</b>	<b>Volume</b>
0.08205 L-atm/mole K	1 atm	273.15 K	22.41 L/g mol
0.08205 L-atm/mole K	1 atm	298.15 K	22.45 L/g mol
62.056 L-mm Hg/mole K	760 mm Hg	273.15 K	22.41 L/g mol
0.73402 ft <sup>3</sup> -atm/lb mol- °R	1 atm	492.7°R	359 ft <sup>3</sup> /lb mol
550 ft <sup>3</sup> -mm Hg/lb mol- °R	760 mm Hg	492.7°R	359 ft <sup>3</sup> /lb mol
Conversions (rounded)	K = °C + 273.15	°R = °F + 459.67	

**Table 2.5** Values and units of the universal gas constant  $R$  in the ideal gas law.

$V_m = 8.3145 \times 273.15 / 101.325 = 22.414 \text{ m}^3/\text{kg mol}$ at 0 °C and 101.325 kPa
$V_m = 8.3145 \times 273.15 / 100.000 = 22.711 \text{ m}^3/\text{kg mol}$ at 0 °C and 100 kPa
$V_m = 8.3145 \times 298.15 / 101.325 = 24.466 \text{ m}^3/\text{kg mol}$ at 25 °C and 101.325 kPa
$V_m = 8.3145 \times 298.15 / 100.000 = 24.790 \text{ m}^3/\text{kg mol}$ at 25 °C and 100 kPa
$V_m = 10.7316 \times 519.67 / 14.696 = 379.48 \text{ ft}^3/\text{lb mol}$ at 60 °F and 14.696 psi (0.8366 ft <sup>3</sup> /gram mole)
$V_m = 10.7316 \times 519.67 / 14.730 = 378.61 \text{ ft}^3/\text{lb mol}$ at 60 °F and 14.73 psi

**Table 2.6** The molar volume of a gas calculated at various standard reference conditions (Wikipedia).

**Example 2.10 MASS OF A GAS**

Calculate the mass of the gas that occupies a volume of 2000 L at 20°C and 1.2 atm and has molar mass = 16 g/mole.

For these units the universal gas constant is 0.08205 L atm/mole K. Absolute temperature: = 20°C + 273 = 293 K.  
From the ideal gas law:  $PV = nRT$

$$(1.2 \text{ atm})(2,000 \text{ L}) = n (0.08205 \text{ L atm/mole K})(293 \text{ K})$$

$$n = 99.8 \text{ moles}$$

$$\text{Total mass of the gas} = (99.8 \text{ moles}) (16 \text{ g/mole}) = 1600 \text{ g}$$

### 2.5.2 Pollutant Concentrations in Gases

Pollutant concentrations in gases can be given in terms of volume (ppmv) or mass (mg/m<sup>3</sup>). Conversion from one form to the other is accomplished using the molar mass (*MM*) of the pollutant and the ideal gas law. One g-mole of an ideal gas occupies a volume 0.02241 m<sup>3</sup> (22.41 L) at standard temperature and pressure (0°C = 273 K and 1 atm). One lb-mole occupies a volume of 359 ft<sup>3</sup> at STP. Also, 1 m<sup>3</sup> of an ideal gas contains  $1/0.02241 \text{ m}^3 = 44.623 \text{ g-moles}$  of the gas.

The mass (mg) of a gas occupying 1 m<sup>3</sup> is

$$\frac{\text{mass of gas (mg)}}{\text{volume of gas (m}^3\text{)}} = \frac{MM \text{ (g/mole)}}{(0.02241)(\text{m}^3/\text{mole})} \times \frac{1000 \text{ mg}}{\text{g}} = \frac{MM(1000)}{0.02241}$$

where *MM* is the molar mass of the gas (g/mole).

If a gas mixture contains a pollutant at a concentration of 1 ppmv, or 1 m<sup>3</sup> of pollutant in 1,000,000 m<sup>3</sup> of mixture, the mass concentration will be given by

$$\frac{\text{mg pollutant}}{\text{m}^3 \text{ mixture}} = \left( \frac{\text{m}^3 \text{ pollutant}}{10^6 \text{ m}^3 \text{ mixture}} \right) \left( \frac{MM \text{ g/mole}}{0.02241 \text{ m}^3/\text{mole}} \right) \left( \frac{1000 \text{ mg}}{1 \text{ g}} \right)$$

$$\frac{\text{mg pollutant}}{\text{m}^3 \text{ mixture}} = \text{ppmv} \left( \frac{MM \times 10^3}{0.02241} \right) \left( \frac{1}{10^6} \right) = \text{ppmv} \left( \frac{MM}{22.41} \right)$$

A simple adjustment is needed when the gas is at non-standard temperature and pressure. The mass of pollutant will remain constant while the volume of the gas in which it is contained expands or contracts. From the ideal gas law, the gas volumes at STP and at actual *T* and *P* are related by

$$\frac{(1 \text{ atm})(V_{STP})}{273} = \frac{P(V_{TP})}{T} \quad \text{or} \quad \frac{V_{STP}}{V_{TP}} = \left( \frac{273}{T} \right) \left( \frac{P}{1 \text{ atm}} \right)$$

The mass concentration at actual *T* and *P* is

$$\left( \frac{\text{mg}}{\text{m}^3} \right)_{TP} = \left( \frac{\text{mg}}{\text{m}^3} \right)_{STP} \left( \frac{273}{T} \right) \left( \frac{P}{1 \text{ atm}} \right)$$

where temperature is Kelvins ( $K = ^\circ\text{C} + 273$ ) and pressure is atmospheres (atm).

Pollution regulations in the United States typically reference their pollutant limits to an ambient temperature of 20 to 25°C as noted in Table 2.4.

**Example 2.11 CONVERTING FROM VOLUME CONCENTRATION TO MASS CONCENTRATION**

The concentration of a gaseous pollutant in air is 50 ppmv. The molecular mass of the pollutant is 16 g/mol. Find the concentration as mg/m<sup>3</sup> at standard conditions.

$$\frac{(\text{ppmv})(MM)}{22.41 \text{ L/mol}} = \frac{(50 \text{ ppmv})(16 \text{ g/mol})}{22.41 \text{ L/mol}} = 35.67 \text{ mg/m}^3$$

**Example 2.12 MASS CONCENTRATION IN GASES**

A gaseous emission has an SO<sub>2</sub> concentration of 25 ppmv. The gas temperature and pressure are 26°C and 1.1 atm. The molar mass of SO<sub>2</sub> is 64 g/mole.

Mass concentration of SO<sub>2</sub> at standard temperature and pressure (STP) of 1 atm and 0°C.

$$\left(\frac{\text{mg}}{\text{m}^3}\right)_{\text{STP}} = \frac{(\text{ppmv})(MM)}{22.41} = \frac{(25)(64)}{22.41} = 71.4 \text{ mg/m}^3$$

Mass concentration at T = 25°C and P = 1.1 atm is

$$\left(\frac{\text{mg}}{\text{m}^3}\right)_{\text{TP}} = 71.4 \left(\frac{273}{273+25}\right) \left(\frac{1.1}{1}\right) = 71.9 \text{ mg/m}^3$$

**Example 2.13 MASS FLOW OF GASES**

A ventilation airflow of 60,000 m<sup>3</sup>/h (at STP) from a printing company contains 1,200 ppmv toluene.

The volumetric flow of toluene is

$$(60,000 \text{ m}^3/\text{h})(1,200 \text{ m}^3/1,000,000 \text{ m}^3) = 72 \text{ m}^3/\text{h}.$$

The density of toluene is 4.12 kg/m<sup>3</sup> (at STP). The mass flow of toluene is

$$(72 \text{ m}^3/\text{h})(4.12 \text{ kg/m}^3) = 297 \text{ kg/h}$$

### 2.5.3 Dalton's Law of Partial Pressure

Dalton's law of partial pressure states that at constant temperature the total pressure exerted by a mixture of gases in a definite volume is equal to the sum of the individual pressures each gas would exert if it occupied the same total volume. In other words, the total pressure of a gas mixture is equal to the sum of the partial pressures of the individual components of the mixture. For a mixture of gases A, B and C, this is

$$P_T = P_A + P_B + P_C$$

**Example 2.14 MIXTURE OF FOUR IDEAL GASES**

The contents of four rigid flasks of one-liter volume are to be mixed together to prepare a calibration gas mixture. The flasks contain sulfur dioxide (SO<sub>2</sub>) at 75 mm Hg pressure, nitrogen (N<sub>2</sub>) at 120 mm Hg, methane (CH<sub>4</sub>) at 45 mm Hg, and carbon monoxide (CO) at 60 mm Hg. What will be the final pressure after these four flasks are combined in a one-liter flask?

$$P_T = P_{SO_2} + P_{N_2} + P_{CH_4} + P_{CO}$$

$$P_T = 75 \text{ mm Hg} + 120 \text{ mm Hg} + 45 \text{ mm Hg} + 60 \text{ mm Hg} = 300 \text{ mm Hg}$$

**Example 2.15 APPARENT MOLECULAR MASS OF DRY AIR**

A gas that is composed of a single species has a molar mass, but a mixture of gases, such as air, does not because there is no thing as an "air molecule." Nevertheless, if one imagines that air does consist of "air molecules", a standard mixture of air can be defined and an apparent molar mass can be calculated.

The molar mass of this mixture will be the weighted average of the molar masses of each of the individual component. Each component will exert its molecular mass ( $M_i$ ) weighted by its volume fraction ( $V_i$ ). The volume fraction is the decimal equivalent of the volume percentage. For example, air is 78.084% nitrogen by volume and the volume fraction of nitrogen is 0.78084. The standard composition of dry air and the calculations are given in Table 2.6

Component	Symbol	Molecular mass ( $M_i$ )	Concentration Percent (%)	Volume fraction ( $V_i$ )	Contribution ( $M_i V_i F_i$ )
Nitrogen	N <sub>2</sub>	28.01	78.084	0.78084	21.871328
Oxygen	O <sub>2</sub>	32.00	20.9476	0.209476	6.703232
Argon	Ar	39.948	0.934	0.00934	0.373114
Carbon dioxide	CO <sub>2</sub>	44.00	0.0314	0.000314	0.013816
Neon	Ne	20.183	0.001818	0.00001818	0.000367
Helium	He	4.0026	0.000524	0.00000524	0.000021
Methane	CH <sub>4</sub>	16.04	0.0002	0.000002	0.000032
Sulfur dioxide	SO <sub>2</sub>	64.06	0.0001	0.000001	0.000064
Hydrogen	H <sub>2</sub>	2.0159	0.00005	0.0000005	0.000001
Krypton	Kr	83.8	0.0000667	0.000000667	0.000056
Xenon	Xe	131.3	0.0000667	0.000000667	0.000088
Ozone	O <sub>3</sub>	48.00	<u>0.0000667</u>	0.000000667	<u>0.000032</u>
			99.9999		$\Sigma M_i V_i F_i = 28.9622$

**Table 2.6** Composition of dry air and the calculation of the apparent molecular mass.

### 2.5.4 Adjusting Pollutant Concentrations to Reference Conditions

Air pollutant concentrations sometimes must be adjusted or ‘corrected’ to concentrations at specified reference conditions of moisture content, oxygen content or carbon dioxide content. For example, a regulation might limit the concentration in a dry combustion exhaust gas to 55 ppmv NO<sub>x</sub> (at a specified reference temperature and pressure) corrected to 3 volume percent O<sub>2</sub> in the dry gas. Another regulation might limit the concentration of total particulate matter to 200 mg/m<sup>3</sup> of an emitted gas (at a specified reference temperature and pressure) corrected to a dry basis and further corrected to 12 volume percent CO<sub>2</sub> in the dry gas. The adjustments are explained by example.

Environmental agencies in the U.S. often use the terms *scfd* (or *dscf*) to denote a ‘standard’ cubic foot of *dry gas*. Likewise, *scmd* (or *dscm*) denotes a ‘standard’ cubic meter of gas. Since there is no universally accepted set of ‘standard’ temperature and pressure, such usage can be confusing. It is recommended that the reference temperature and pressure always be clearly specified when stating gas volumes or gas flow rates.



Join the best at  
the Maastricht University  
School of Business and  
Economics!

#### Top master's programmes

- 33<sup>rd</sup> place Financial Times worldwide ranking: MSc International Business
- 1<sup>st</sup> place: MSc International Business
- 1<sup>st</sup> place: MSc Financial Economics
- 2<sup>nd</sup> place: MSc Management of Learning
- 2<sup>nd</sup> place: MSc Economics
- 2<sup>nd</sup> place: MSc Econometrics and Operations Research
- 2<sup>nd</sup> place: MSc Global Supply Chain Management and Change

Sources: Keuzegids Master ranking 2013; Elsevier 'Beste Studies' ranking 2012; Financial Times Global Masters in Management ranking 2012

Maastricht University is the best specialist university in the Netherlands (Elsevier)

Visit us and find out why we are the best!  
Master's Open Day: 22 February 2014

[www.mastersopenday.nl](http://www.mastersopenday.nl)



Click on the ad to read more



**Example 2.16** ADJUSTING GAS COMPOSITION TO A DRY BASIS

A gaseous emission has a pollutant concentration of  $C_{wet\ basis} = 40$  ppmv and 10 volume percent of water vapor. The 40 ppmv should be designated as the "wet basis" pollutant concentration. The adjustment of the measured "wet basis" concentration to a "dry basis" concentration is done using

$$C_{dry\ basis} = \frac{C_{wet\ basis}}{1-W}$$

where:  $C$  = Concentration of the air pollutant in the emitted gas  
 $W$  = fraction, by volume, of water vapor in the emitted gas

$$C_{dry\ basis} = \frac{40}{1-0.1} = 44.4\text{ ppmv}$$

**Example 2.17** ADJUSTING GAS COMPOSITION TO A REFERENCE OXYGEN CONTENT

A measured  $\text{NO}_x$  concentration of 45 ppmv in a dry gas having 5 volume %  $\text{O}_2$ . This is adjusted to give a measured pollutant concentration in a dry emitted gas with a measured  $\text{O}_2$  content to an equivalent pollutant concentration in a dry emitted gas with a specified reference amount of  $\text{O}_2$  using

$$C_R = C_M \left( \frac{20.9 - (\% \text{O}_2)_R}{20.9 - (\% \text{O}_2)_M} \right)$$

where:  $C_R$  = corrected concentration of a dry gas with a specified reference volume %  $\text{O}_2$   
 $C_M$  = measured concentration in a dry gas having a measured volume %  $\text{O}_2$   
 $(\% \text{O}_2)_R$  = percentage of oxygen in the reference volume  
 $(\% \text{O}_2)_M$  = percentage of oxygen in the measured volume

The  $\text{NO}_x$  concentration, when corrected to a dry gas having a specified reference  $\text{O}_2$  content of 3 volume % is

$$C_R = 45 \left( \frac{20.9 - 3.0}{20.9 - 5.0} \right) = 50.7\text{ ppmv NO}_x$$

Note: The measured gas concentration  $C_m$  must first be corrected to a dry basis before using the above equation.

**Example 2.18** ADJUSTING GAS COMPOSITION TO A REFERENCE CARBON DIOXIDE CONTENT

A dry gas has a measured particulate concentration is 200  $\text{mg/m}^3$  and a measured 8 volume %  $\text{CO}_2$ . This can be corrected to an equivalent pollutant concentration in an emitted gas that has a specified reference amount of 12 volume % of  $\text{CO}_2$ .

$$C_R = C_M \frac{(\% \text{CO}_2)_R}{(\% \text{CO}_2)_M} = 200 \left( \frac{12}{8} \right) = 300\text{ mg/m}^3$$

where:  $C_R$  = corrected concentration of a dry gas having a specified reference volume %  $\text{CO}_2$   
 $C_M$  = measured concentration of a dry gas having a measured volume %  $\text{CO}_2$   
 $(\% \text{CO}_2)_R$  = percentage of carbon dioxide in the reference volume  
 $(\% \text{CO}_2)_M$  = percentage of carbon dioxide in the measured volume

## 2.6 Conclusion

Pollutants have many physical and chemical forms. They may be carried by water or some other liquid, or by air or some other gas, or they may be part of a solid material, such as soil. They may be dissolved or particulate.

Specific chemicals, such as copper, chlorine, or benzene, are measured as copper, chlorine, or benzene. In wastewater treatment, pollutants with similar properties are lumped together because it is too difficult to measure individual species or simply because it is not necessary. Suspended solids, volatile solids, dissolved solids, biochemical oxygen demand, and chemical oxygen demand are 'lumped' measurements.

Likewise, environmental quality standards may be written for specific chemicals, which is the case for toxic air and water pollutants, or for lumped parameters in most municipal wastewater effluents.

This variety of pollutant forms and measurements generates the need to use a variety of units, such as mg/L in water, mg/kg in solids, and volume percent or ppmv in air and gases.

The difficulty in working with unfamiliar units is not making the arithmetic conversions between systems. It is losing one's sense of the magnitude of quantities. Working in treatment plants where flows are measured in gallons and million gallons, and where pipes are measured in inches, gives the experienced engineer an instinctive sense of the correct size. Working in cubic meters and centimeters creates a questioning attitude of "How big is that?" or "Does that seem about the right size." We hope students who use this book are not too much troubled by that feeling, when the examples are in unfamiliar units.



**> Apply now**

REDEFINE YOUR FUTURE  
**AXA GLOBAL GRADUATE  
PROGRAM 2015**

redefining / standards 

agence.cdg. © Photonistop



# 3 Pollution Prevention

## 3.1 The Design Problem

This chapter is different than the others. It is about ideas and not calculations. The goal is to demonstrate how knowing the material balance will stimulate ideas about pollution prevention and control. The ideas are illustrated with case studies that show the materials that move through the manufacturing and pollution control system. In all cases, mass in equals mass out, which is required by the law of conservation of mass. The examples are quantitative, but the methods of calculating the material balance are not discussed until Chapter 4.

The case studies are food processing, metal fabrication, organic chemical manufacturing, and semiconductor manufacturing. A possible first reaction may be “I don’t know anything about those industries. I won’t be able to understand the case studies.” Don’t be intimidated. There will be unfamiliar names of processes, chemicals and equipment, but you need not worry too much about these details. Focus on what the case studies have in common – the *material balance concept* – and you will learn.

Pollution prevention is done in the manufacturing process. Watch for the changes that reduce water use and waste quantities. Waste treatment is done on whatever materials are discharged as waste liquids, gas, or solids. Watch for how the characteristics of the wastes, in particular the presence of toxic chemicals, will influence decisions about waste management. These concepts, and the material balance, are useful in any kind of process. That is the message of this chapter.

Some students may wish to come back to this chapter when they are more familiar with basic concepts and vocabulary. This is fine, and a second reading is recommended, but do not skip over it on the first reading. It will be helpful to use the examples to build the concept of processing systems and how they can be rearranged and improved, and how the material balance data guides the innovation.

The goal in pollution prevention is to find low-cost or no-cost improvements to save money. The savings may come from higher yield, reclaimed material, lower utility costs, lower raw material cost, or lower waste disposal cost. During design these savings are made or lost at the drawing board.

An existing industry must first find waste and then reduce it. Accounting for all the material flowing through the system is the ultimate material balance exercise. Acquiring the necessary data requires a good deal of care and effort. Many industries do not know the flow of water into or the flow of waste materials out of various processes. Sometimes the best estimate of a pollutant discharge comes from purchasing records. It may be known, for example, that mercury is being purchased and put into the process, but mercury is not detected in the discharges from the plant (Caban & Chapman 1972).

## 3.2 Pollution Audit – The First Steps

The first step for an existing industry is to walk through manufacturing areas, plant utilities, and waste treatment facilities and look for waste.

- Look in the waste bins.
- Identify the various waste streams produced on site.
- Look at packaging for both suppliers and customers. Packaging is paid for twice – once to buy it and once to dispose of it.
- Water use and disposal is critical because you pay for the clean water input and the wastewater output. Check meters and bills to be sure you pay only for what you are discharging. Turn off water to idle processes. Eliminate leaks and dripping faucets.
- Look for energy savings. Saving water almost always saves energy, and vice versa.
- Compressed air leaks are expensive, but easy to find and eliminate.

Information about the manufacturing and waste treatment processes must be organized.

1. *Draw a flow diagram of the manufacturing process.* The starting diagram might look like Figure 3.1. Many details remain to be filled in.
2. *Identify and quantify all raw material inputs, products and byproducts.* Help will be needed from the purchasing department. Many raw materials are sold under trade names so it may take some work to discover the chemical components. Material safety data sheets are useful here.
3. *Check all permits, compliance test data, violations and complaints, past and potential spills, underground tank inventory, and accidental containment plans.*
4. *Identify the source of all pollutants and waste discharges (solid wastes, drums, and gaseous emissions as well as wastewater).* Fugitive gaseous emissions represent a special challenge to locate and quantify. Maps of drainage and ventilation ducts must be checked. Existing plans may be wrong in the details of plumbing and drainage and some sewers and drains may not be shown at all. It may be necessary to use dye or smoke to trace some discharges. Flow meters and sampling devices may need to be installed.
5. *Quantify all discharges in terms of flow and contaminant levels.* Make the material balance on water and other contaminants. Getting an accurate accounting of material flow in a real system requires care and effort. If the material balance is based, wholly or in part, on field measurements, there will be discrepancies due to imperfections in the measurement process or failure to identify and measure all inputs and outputs. Similar problems exist with regard to getting representative samples of discharges and of measuring concentrations in the laboratory. All sampling must be coordinated with the laboratory to eliminate mistakes about sample preservation, sample size, and whether measurements will be made in the field (pH, temperature) or in the laboratory.

6. Use the material balance to identify opportunities for improvement by ranking pollution sources in terms of magnitude, toxicity, or treatment cost. Develop a list of ideas, screen and rank them, and work toward implementing the best.

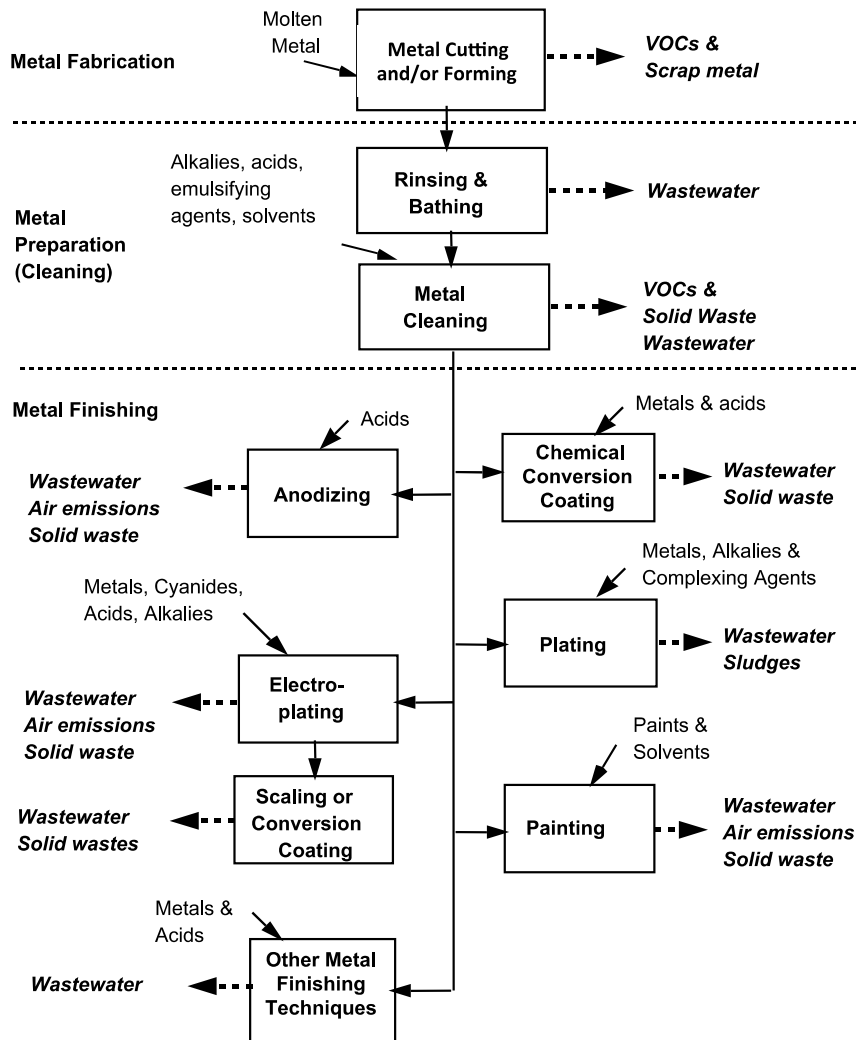


Figure 3.1 Preliminary process flow diagram for a pollution audit.

### 3.3 Case Study – Sweet Potato Canning

A sweet potato canning factory processes sweet potatoes coming directly from the fields. Operation is 10 h/day, 6 days a week, for a six-week season. Figure 3.2 shows the amount of water used and the pollutant load from each manufacturing step for an input of 1,000 kg/h. There is no way to compute these values from theory so they must be measured in the plant. This is laborious and expensive, but necessary to support intelligent redesign decisions.

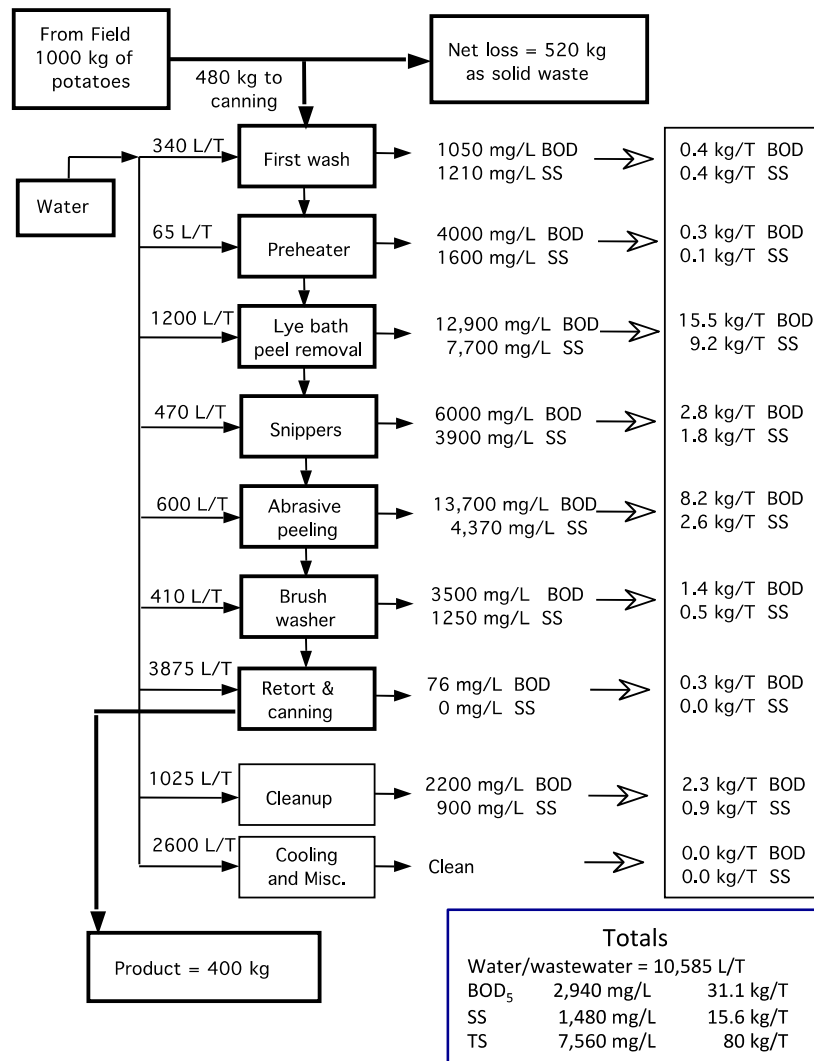


Figure 3.2 Material balance for water, BOD and suspended solids in a sweet potato canning plant.

For every 1000 kg (1 T) of sweet potatoes that comes from the field, 400 kg leaves as canned product, 520 kg is lost immediately as solid waste (dirt, plant material, and substandard vegetables), and 80 kg leaves in the wastewater.

The total water use is 10,585 L/T. One-third of this is used for cleanup and cooling. Another one-third is used in the canning process. Preparation for canning (lye bath peel removal, snippers, abrasive and brush washer) accounts for another 25% of water use. The retorts (industrial pressure cookers) use the most water, but the wastewater is clean. Cleanup uses a lot of water and contributes six to eight percent of the pollutant load. The cooling water is a large volume but it never becomes polluted.



Biochemical oxygen demand (BOD) and suspended solids (SS) are the only pollutants of interest in this industry. The pollutant concentrations of the combined wastewater are 2,940 mg/L BOD and 1,480 mg/L SS. The mass pollutant loads per ton of product are 31.1 kg BOD and 15.6 kg of SS. The lye bath/peel removal, snippers, and the abrasive peelers are the source of roughly 90% of the BOD and SS loads. Slightly more than half of the total BOD load comes from the lye bath peel removal step. Abrasive peeling contributes 25% of the BOD load. Peeling accounts for almost all of the suspended solids load.

Peeling is the first target for process redesign. A search of the food processing literature and consultation with experts suggests dry caustic peeling as an option. The peel is removed as a pasty solid. This eliminates the abrasive scrubbing step and reduces the wastewater flow by 80% and BOD and SS loads by 90%. The estimated waste reductions are in Table 3.1



**Empowering People.  
Improving Business.**

BI Norwegian Business School is one of Europe's largest business schools welcoming more than 20,000 students. Our programmes provide a stimulating and multi-cultural learning environment with an international outlook ultimately providing students with professional skills to meet the increasing needs of businesses.

BI offers four different two-year, full-time Master of Science (MSc) programmes that are taught entirely in English and have been designed to provide professional skills to meet the increasing need of businesses. The MSc programmes provide a stimulating and multi-cultural learning environment to give you the best platform to launch into your career.

- MSc in Business
- MSc in Financial Economics
- MSc in Strategic Marketing Management
- MSc in Leadership and Organisational Psychology

**BI NORWEGIAN BUSINESS SCHOOL**

EFMD  
**EQUIS**  
ACCREDITED

[www.bi.edu/master](http://www.bi.edu/master)



Item	Original Process	Dry Caustic Process
Process input	10 T/h	10 T/h
Peel loss	12% = 1.2 T/h	6% = 0.6 T/h
Canned output	8.8 T/h	9.4 T/h
Water/Wastewater	10,585 L/h	2,120 L/h
BOD	311 kg/h	31.1 kg/h
SS	156 kg/h	15.6 kg/h
<b>Water and Wastewater Costs</b>		
Water purchase @ \$0.70 per m <sup>3</sup>	\$7.41/h	\$1.48/h
Wastewater surcharge		
– BOD @ \$0.15/kg	\$46.65/h	\$4.67/h
– SS @ \$0.10/kg	\$15.60/h	\$1.56/h
Solid waste disposal @ \$25/T	\$30/h	\$15/h
Total Costs (\$/h)	\$92.25	\$21.23
Total cost (\$/10-hour day)	\$922.50	\$212.30

**Table 3.1** Waste loadings for the conventional process and the dry caustic process.

There are direct cost savings by reducing water use, chemicals, steam, fuel, and waste surcharges. In addition there will be slightly more product to sell because peel loss is reduced. The savings from wastewater and solids disposal and water purchased is \$710 per day or \$25,560 per canning season.

Are there other improvements to consider? It may be possible to recycle some water from the retort to the first washing step. The lye can be cleaned of solids and reused. The high-solids water coming from washing, snipping, brush washers, and trimming could be screened to remove 60–80% of the solids. This simultaneously reduces the BOD and the wastewater disposal costs.

Making the material balance was the key to setting priorities and selling the solution to management.

### 3.4 Case Study – Water Reuse and Toxic Metals Management

An industry uses 12 L/m of city water to supply three manufacturing processes. The process water contains 200 ppm total dissolved solids (TDS), which is excellent for the manufacturing process.

The objectives are to minimize the discharge to the city sewer, eliminate the toxic sludge, and minimize all waste outputs.

Table 3.2 and Figure 3.3 summarize what is known. The three waste streams are combined for treatment. The tumbler water contains about 5,000 ppm of non-toxic suspended solids. The acid-etch water contains dissolved toxic metals. The alkaline rinse water contains 230 ppm TDS but is not toxic.

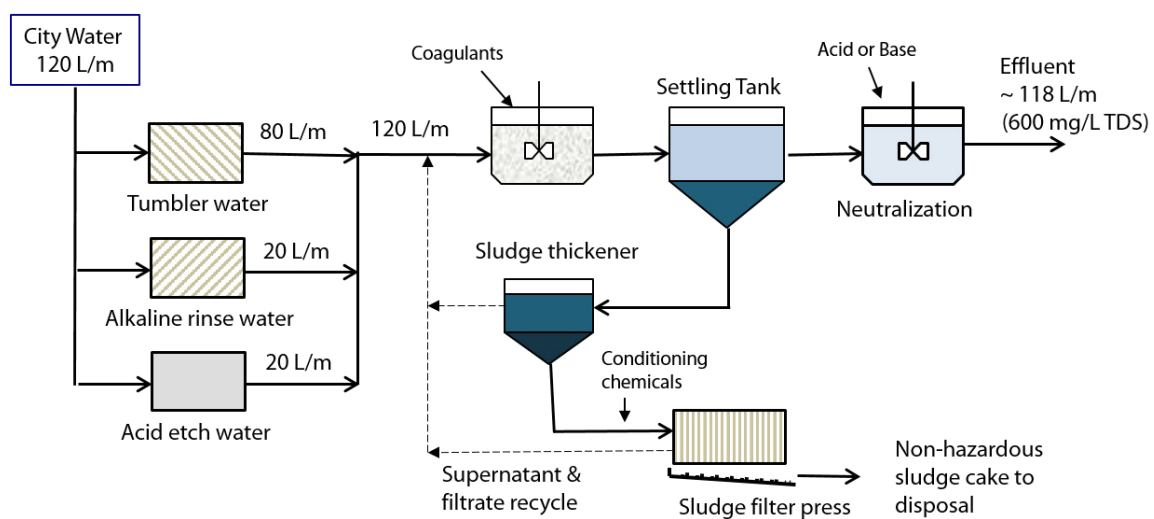
Most of the solids, which are non-toxic, come from the tumbler water. The pollutants carried in the acid etch water and alkaline rinse water are dissolved; they are free of suspended solids. The alkaline rinse water is not important in terms of pollution, but it contributes 20 L/m, or 17%, of the total flow.

Coagulants enhance the removal of suspended solids in a settling tank. This also causes the removal of some toxic metals so sludge from the settling tank is contaminated with toxic metals from the acid etch rinse. The sludge is thickened by gravity and dewatered in a filter press. Mixing the metals with the non-toxic tumbler solids creates a filter cake that must be handled as a hazardous waste.

The effluent is neutralized by adding acid or base as needed. The effluent has a total dissolved solids concentration of 600 mg/L TDS, which is too high for water reuse.

Water Source	Flow (L/m)	TSS (mg/L)	TDS (mg/L)	Toxic	Direct Reuse
City water	120	nil	200	No	NA
Tumbler water	80	5,000 (0.4 kg/h)	< 200	No	Yes (low TSS)
Acid etch water	20	nil	< 400	Yes	No
Alkaline rinse water	20	nil	< 400	No	No
Effluent	180	< 10 mg/L	600 mg/L	No	No (high TDS)
Sludge filter cake	--	20–30 kg/d	--	Yes	No

**Table 3.2** Characterization of water use and wastewater treatment. (TSS = total suspended solids; TDS = total dissolved solids)



**Figure 3.3** Wastewater Treatment Process Mass balance on water neglects water in sludge cake.

The salt that prevents the effluent from being recycled is proportional to the drag-out from the acid etch and alkaline rinses. The chemicals added for neutralization are also proportional to the drag-out and they increase the salinity.

The engineers have some ideas after seeing the material balance information.

Engineer 1      We should treat the tumbler water separately with some sort of solid-liquid separation process. Removing the suspended solids should make the water suitable for reuse. The solids will be non-hazardous for purposes of disposal to a landfill.

Engineer 2      True, that would mean having two clarifiers, one for the tumbler water and one for the other combined wastes. There is no room to build a new unit for this waste stream

Engineer 1      There are other ways to removed solids, like microfiltration. This is a membrane process that is widely used and extremely versatile. I would expect to find a membrane that would do the job.

Engineer 2      Let's make a quick phone call to Membranes International.

*A short time later.*

## Need help with your dissertation?

Get in-depth feedback & advice from experts in your topic area. Find out what you can do to improve the quality of your dissertation!

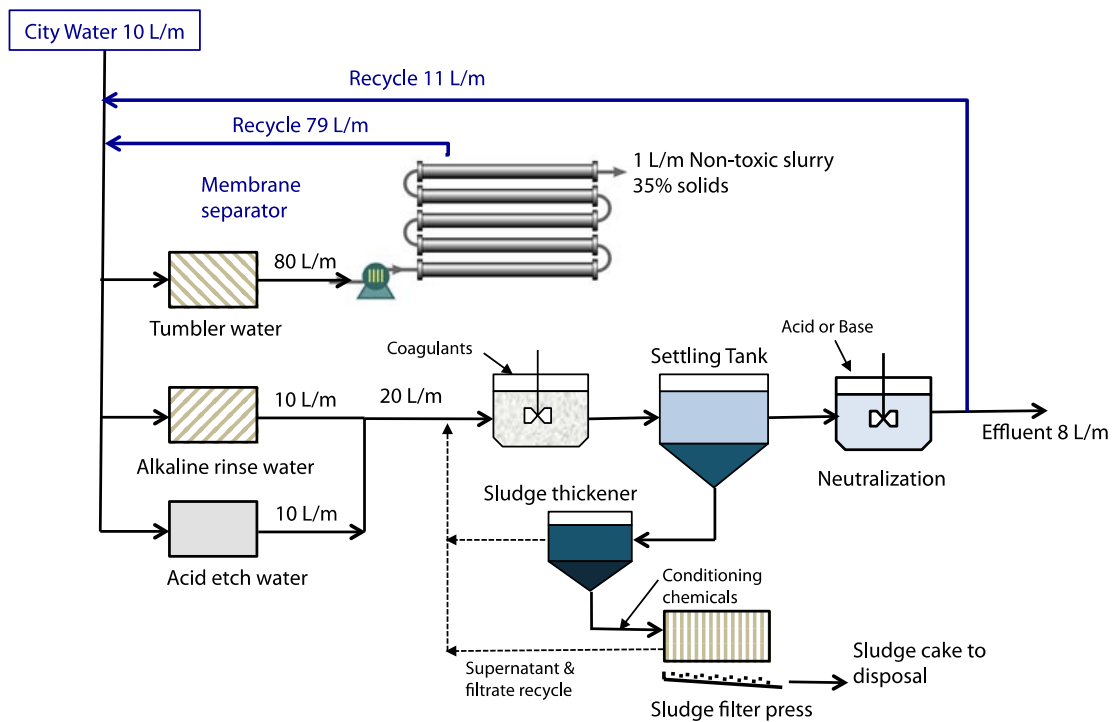
Get Help Now



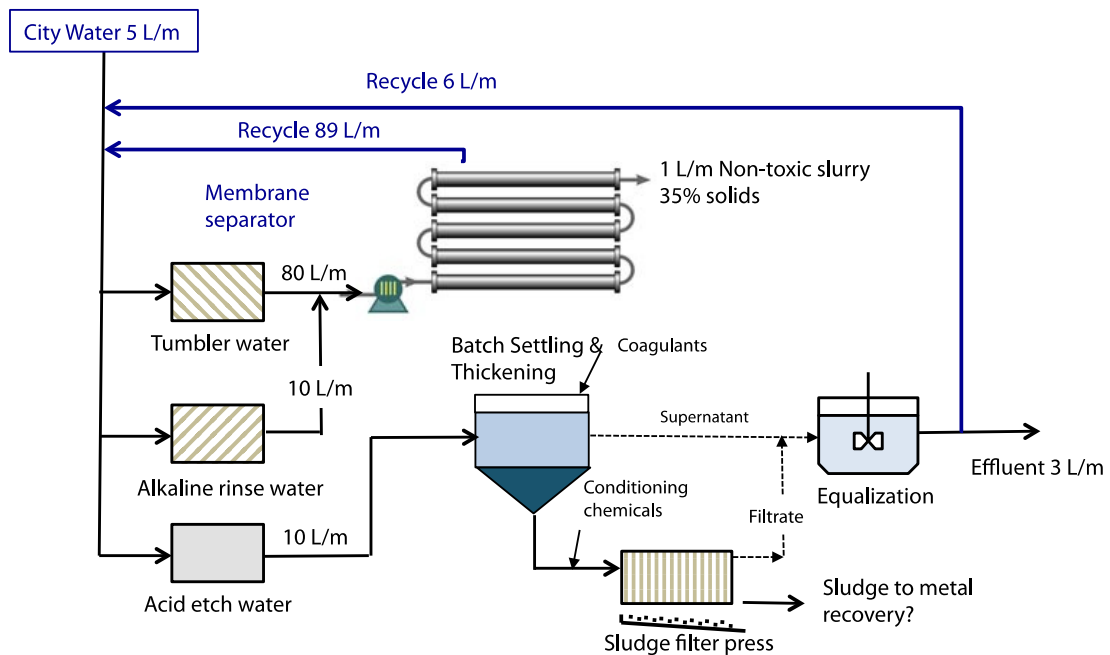
Go to [www.helpmyassignment.co.uk](http://www.helpmyassignment.co.uk) for more info

 **Helpmyassignment**

- Engineer 2      You are right. There is an ultrafiltration system that will deliver excellent water with 500–600 ppm TDS and a reject slurry with 35% solids. The volume of water in the slurry is 1 L/m or less, so let's say we can recycle the 79 L/m of tumbler water. The operating pressure is reasonable. This slurry will be non-hazardous and therefore disposal is not a problem.
- Engineer 1      The next step should be to reduce the drag-out from the acid etch and alkaline rinses. This will reduce the salt buildup and the metals in the sludge.
- Engineer 2      There are low-cost ways to do that. Modify the drip tanks and put in air knives to blow-dry the parts before rinsing. Put in automatic shut-off valves and countercurrent rinsing. That will reduce each rinse by half and the salt content will be low. We could recycle 11 L/m water. We can't recycle everything. Our effluent is like the blow-down on a cooling tower or a boiler. Some effluent is needed to control the salt build up.
- Engineer 1      That gets us to the flow sheet shown in Figure 3.4. That is a nice improvement. The volume of sludge and the metals content are greatly reduced. The sludge may still be hazardous, depending on the metal concentration and its stability in the RCRA leaching test.
- Engineer 2      We could treat the acid-etch water separately. This would reduce the sludge volume and it might make metal recovery possible.
- Engineer 1      Right. And the volume is so small – the volume for one day is 10,800 L (10 L/m for 18 hours), the same as the flow for one hour when we used 180 L/m of city water. That means the existing settling tank has sufficient volume to treat one day's waste as a batch. Add chemicals directly to the settling tank, mix it, settle the precipitate, allow the sludge to thicken, and dewater it.
- Engineer 2      What happens to the alkaline rinse? It's non-toxic. We might mix it with the tumbler water and use the ultrafiltration system to recover a few more liters of water.
- Engineer 1      Figure 3.5 is a sketch of the proposed system. Details need to be checked to be sure it will work, but it is an excellent working plan. City water purchase is reduced from 120 L/m to 5 L/m. Most solids are in a non-toxic slurry. The metals are concentrated in a very small volume of sludge.



**Figure 3.4** Redesigned process. Mass balance assumes 1 L/m water in sludge cake and 1 L/m in membrane process slurry.



**Figure 3.5** Flow diagram for the final proposal. Mass balance assumes 1 L/m water in sludge cake and 1 L/m in membrane process slurry.



### 3.5 Case Study – Reducing Phenol Emissions

An industry produces approximately 100,000 kg/d of phenolic chemicals using a batch process to react a chlorinated organic chemical with an excess of a phenolic chemical. The reaction is carried out in an aqueous solution. The products can be a variety of specific chemicals, depending upon the chemical that is reacted with phenol.

Phenol, caustic (NaOH), an organic chloride (R-Cl) and water are charged to a reactor. After a brief period of mixing and settling, sulfuric acid and benzene are added. When the reaction reaches the desired state the organic layer that contains benzene, unreacted raw material, and product is decanted. A large volume of brine is discarded as waste. Washwater comes from cleaning the equipment with water at the end of processing.

Wastewater is restricted to less than 0.1 mg/L phenol and less than 0.05 mg/L benzene. Emissions of total organics to the air is limited to 4.5 kg/d maximum and 2 kg/h maximum. Present performance, given in Table 3.3 and Figure 3.6 shows that the existing system violates the air and water pollution laws. A pollution audit is needed to discover where and how the emissions originate.



**Brain power**

By 2020, wind could provide one-tenth of our planet's electricity needs. Already today, SKF's innovative know-how is crucial to running a large proportion of the world's wind turbines.

Up to 25 % of the generating costs relate to maintenance. These can be reduced dramatically thanks to our systems for on-line condition monitoring and automatic lubrication. We help make it more economical to create cleaner, cheaper energy out of thin air.

By sharing our experience, expertise, and creativity, industries can boost performance beyond expectations. Therefore we need the best employees who can meet this challenge!

The Power of Knowledge Engineering

Plug into The Power of Knowledge Engineering.  
Visit us at [www.skf.com/knowledge](http://www.skf.com/knowledge)

**SKF**

A typical batch leaving the decanter contains 70% benzene, 28% product, 1% phenol, and some tars. This is fractionated by distillation in stages. The first stage removes benzene and phenol for recycle over a 10-hour period. In the second phase, 98% of the product is recovered over a one-hour period. At the conclusion of the distillation, 25,000 kg of tars remain in the still. Tars are stored in a pond, but new regulations prohibit this in the future.

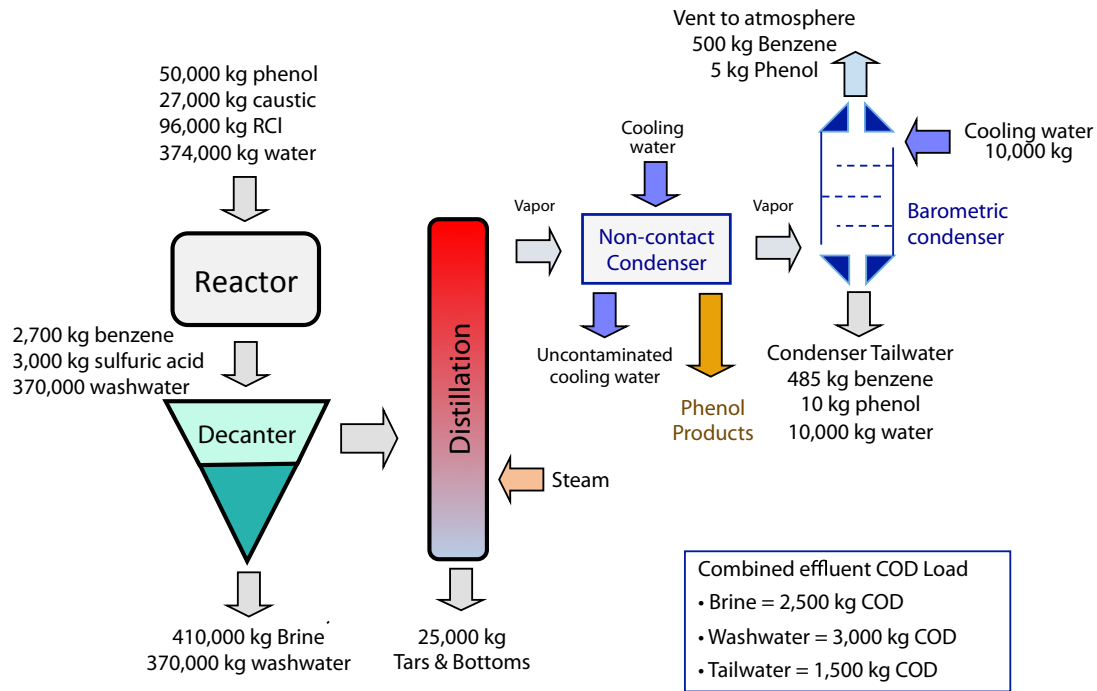


Figure 3.6 Phenolics processing system.

Material	Inputs (kg)	Brine (kg)	Wash water (kg)	Tailwater (kg)	Combined Effluent (kg)	Tars (kg)	Vent (kg)	Total Out (kg)
<b>Water</b>	744,000	361,980	370,000	10,000	741,980	1,500	520	744,000
<b>Chemicals</b>	178,700	48,020	2,230	495	50,745	23,500	505	51,250
Phenol (C <sub>6</sub> H <sub>6</sub> O)	50,000	420	370	10	800		5	805
Caustic (NaOH)	27,000							
Organic chloride (R-Cl)	96,000							
Benzene (C <sub>6</sub> H <sub>6</sub> )	2,700	1,100	660	485	2,245		500	2,745
Sulfuric acid (H <sub>2</sub> SO <sub>4</sub> )	3,000							
NaCl		42,000	1,000		43,000			43,000
Na <sub>2</sub> SO <sub>4</sub>		4,500	200		4,700			4,700
<b>Total Mass</b>	<b>922,700</b>	<b>410,000</b>	<b>372,230</b>	<b>10,495</b>	<b>792,725</b>	<b>25,000</b>	<b>1,205</b>	<b>818,230</b>
<b>Pollutants</b>								
• BOD	-	1,500	1,800	700	4,000			4,000
• COD	-	2,500	3,000	1,500	7,000			7,000
Notes:	Water inputs = Reactor feed + Washwater + Barometric condenser water Uncontaminated cooling water not included in effluent. Small amounts of product in the effluent are ignored.							

Table 3.3 Daily average wastewater flows and concentrations, and daily mass loads.

The distillate is condensed using a water-cooled non-contact condenser followed by a two-stage steam jet and a direct-contact condenser. Non-contact means that the cooling water and the condensed vapor are separated by a metal surface so the cooling water is not contaminated. The water effluent from the direct-contact condenser is called the tailwater. It is heavily contaminated because the cooling water is sprayed into the vapor and whatever chemical is removed becomes part of the tailwater. There are losses of 500 kg of benzene and 5 kg of phenol through the condenser to the atmosphere. In addition, 485 kg of benzene and 10 kg of phenol are lost to the sewer in the condenser tailwater.

The obvious change is to increase the efficiency of the condensers. The direct-contact condenser will be removed. Condensing capacity can be increased by installing a larger condenser, or by using a colder condensing fluid. This will reduce air emissions and keep benzene and phenol out of the wastewater.

If condensation alone cannot solve the problem, additional emission controls will be needed, such as an incineration or adsorption system. Heat recovery from an incinerator might be economical. Benzene recovery from a carbon adsorption system would be possible.

The still bottoms are combustible. They could be incinerated to produce steam for use in the distillation process, or they might be shipped elsewhere for burning.

Phenol and benzene are both biodegradable so the water pollution problem could be solved with biological wastewater treatment at the industry or in a municipal facility. Disadvantages, aside from cost, are that these chemicals are destroyed and not available for reuse, sludge will be produced, and volatilization of the benzene from the treatment plant might be an air pollution problem in itself. The goal should be to eliminate these chemicals from the wastewater.

It should be possible to reuse the washwater in the reactor, recover phenol by adsorption, segregate cooling water so it does not become contaminated, and practice other pollution prevention strategies, such as finding a less toxic solvent to replace benzene.

### 3.6 Case Study – Reclaiming Gallium Arsenide from Semiconductor Manufacturing

Gallium arsenide, a mixture of gallium and arsenic, is a semiconductor that is used to make computer chips and solar panels. Gallium is a byproduct of the smelting of other metals, notably aluminum and zinc. It is more rare than gold. Arsenic is toxic.

More than 15 steps are needed to make gallium arsenide (GaAs) semiconductor crystals, including crystal growth, ingot grinding, wafer slicing, etching, cleaning, etc. Several of these steps generate a waste slurry of fine GaAs particles. In addition there is hydrofluoric acid (HF) from wafer etching waste and acid waste streams from other processing operations. Figure 3.7 summarizes the material balance on gallium arsenide.

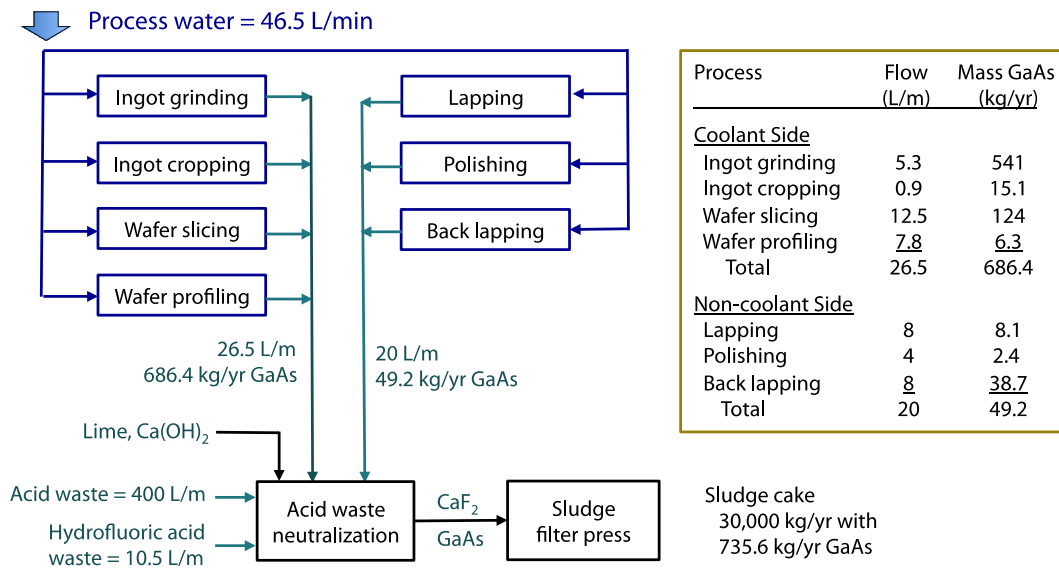
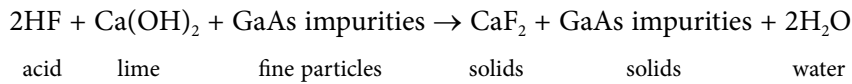


Figure 3.7 Original wastewater management scheme for the semiconductor manufacturing (Hertz 1990).

All wastewater is combined for neutralization with lime,  $\text{Ca}(\text{OH})_2$  which precipitates  $\text{CaF}_2$ . The overall chemical material balance is



**What do you want to do?**

No matter what you want out of your future career, an employer with a broad range of operations in a load of countries will always be the ticket. Working within the Volvo Group means more than 100,000 friends and colleagues in more than 185 countries all over the world. We offer graduates great career opportunities – check out the Career section at our web site [www.volvogroup.com](http://www.volvogroup.com). We look forward to getting to know you!

**VOLVO**  
AB Volvo (publ)  
[www.volvogroup.com](http://www.volvogroup.com)

VOLVO TRUCKS | RENAULT TRUCKS | MACK TRUCKS | VOLVO BUSES | VOLVO CONSTRUCTION EQUIPMENT | VOLVO PENTA | VOLVO AERO | VOLVO IT  
VOLVO FINANCIAL SERVICES | VOLVO 3P | VOLVO POWERTRAIN | VOLVO PARTS | VOLVO TECHNOLOGY | VOLVO LOGISTICS | BUSINESS AREA ASIA



The CaF<sub>2</sub> and GaAs solids are removed with the sludge, which is dewatered with a filter press. The arsenic makes the sludge cake a hazardous waste that contains 735.6 kg/yr of GaAs solids.

Obviously the form of the arsenic is critical in choosing a treatment process. The arsenic in this wastewater exists primarily as 10-micron particles that can be removed by filtration. Figure 3.8 lists some feasible solid-liquid separation processes.

The redesigned process keeps the coolant side and the non-coolant side wastewaters separate to facilitate water recovery. The coolant side slurry recovery process is a filter that recovers 620 kg/yr of GaAs solids. The filter backwash water is combined with the HF wastewater and neutralized.

The filtrate from sludge processing is combined with the hydrofluoric acid waste for treatment with lime. The chemistry is the same as shown earlier, but the volume of water treated is reduced and the filter cake now contains 113.1 kg/yr GaAs (54.5 kg Ga and 58.6 kg As). At this concentration the arsenic contaminant in the CaF<sub>2</sub> sludge cake is low enough that the sludge is not classified as hazardous and the sludge can be sold. The high pH filtrate from the sludge dewatering is used to neutralize the dilute acid waste stream. The neutralized effluent can be discharged to the sewer system. The redesigned system for arsenic recovery is shown in Figure 3.9.

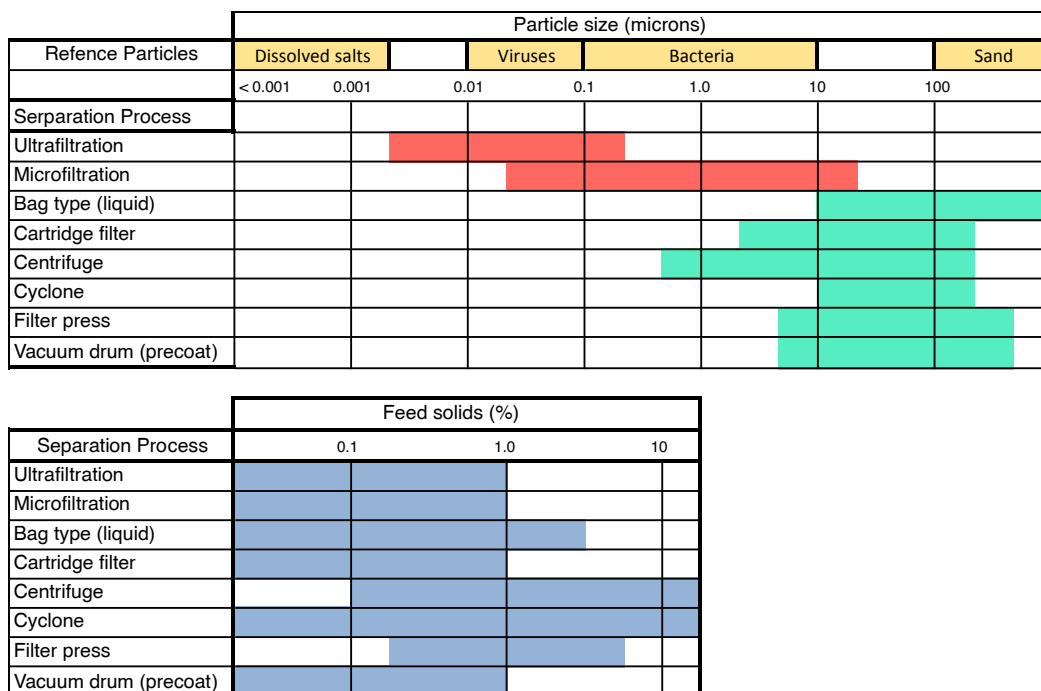


Figure 3.8 Some possibilities for separating particulate GaAs from water.

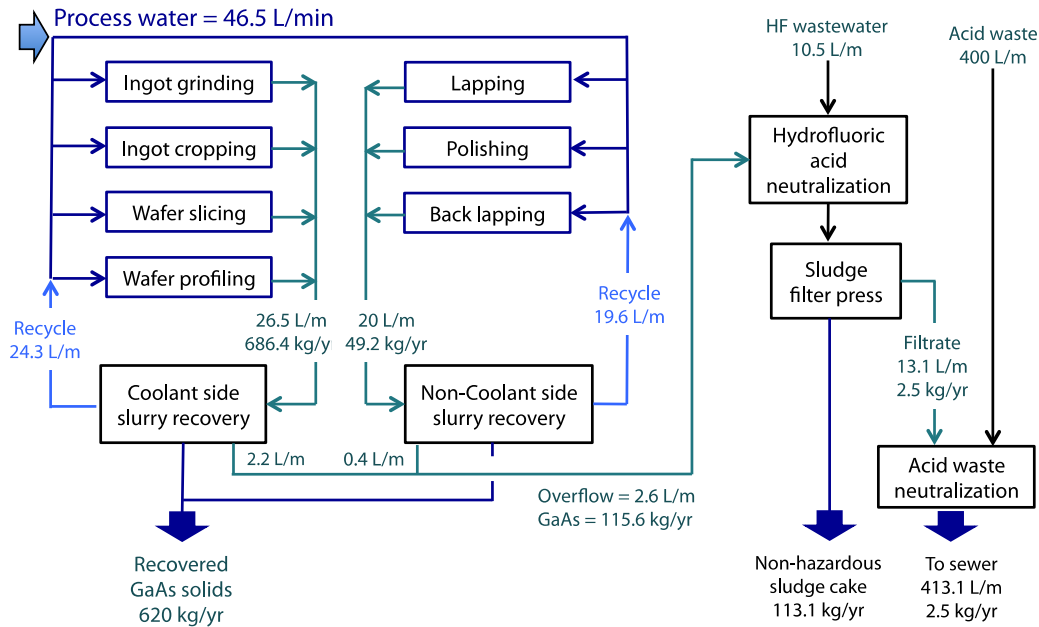


Figure 3.9 Redesigned wastewater treatment system for arsenic recovery (Hertz 1990).

It was estimated (Hertz 1990) that there would be savings of \$35,000 per year in landfill costs for sludge disposal costs if the sludge did not contain arsenic and \$100,000 could be earned from the sale of  $\text{CaF}_2$ . If GaAs could be recovered, its value would be \$5,000 per year. In addition there would be an estimated \$15,000 savings in reduced safety and health costs. The price of gallium today is \$700/kg.

### 3.7 Conclusion

The material balance is the most valuable tool for determining the magnitude of a pollution problem and stimulating ideas about pollution prevention. We use it to expand fragmentary information into a more complete picture that stimulates the synthesis-analysis iterative cycle. The methods for doing this are explained in the next chapter.

Opportunities for pollution prevention in an existing plant may be discovered during a plant walk-around and from discussions with operators and plant engineers. When the easy fruit has been harvested, sampling and analytical work may be needed to assemble the necessary flow and pollutant load data. We have skipped over the important details of how to design a sampling program, how to measure flows and collect representative samples, and the parameters that should be measured. Data are expensive, but information is valuable and short cuts will not be rewarded.

The plant 'walk-around' during design is a creative exercise to imagine the kinds and sources of possible pollution and to use material balance calculations to estimate quantities. In particular, we hope to discover opportunities to minimize the creation of wastes and to recover and recycle material. Recognizing that zero emissions is almost never possible, the material balance also guides the designer in formulating treatment systems to deal with pollutant discharges that cannot be avoided.



# 4 Conservation of Mass

## 4.1 The Basic Principle

*Conservation of mass* means that mass is neither created nor destroyed during ordinary physical, chemical, and biological activities. Using the law of conservation of mass to account for material is commonly referred to as making a *material balance* or making a *mass balance*.

The law of conservation of mass is much like the principles of accounting used to keep track of money in a bank. The bank does not create or destroy money. All the money that enters a bank in a given period must accumulate in the vault or leave the bank.

In the same way, all the mass that enters an enclosed region must accumulate within the region or leave the region. We are concerned only with the passage of material across the boundaries of a region. The internal details of the machinery are not important.

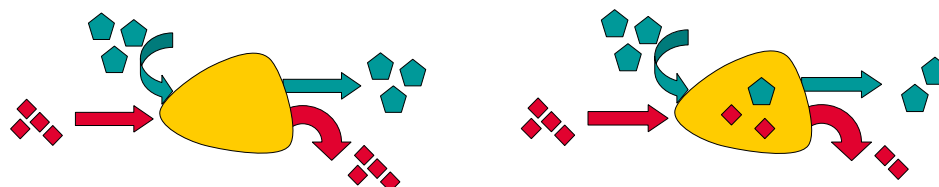
The basic material balance, pictured in Figure 4.1, is

$$[\text{total mass in}] - [\text{total mass out}] = \left[ \begin{array}{l} \text{accumulation of} \\ \text{mass in the region} \end{array} \right]$$

The left-side diagram is a special case where there is no accumulation of material within the region. The right-side shows the more general material balance.

The balance is maintained even when material species are being created or destroyed within the region. If a solid is converted to a gas by combustion, the mass of the solid destroyed must equal the mass of combustion products that are created. (Also, since we are not concerned with nuclear explosions or generating energy in a nuclear reactor, our atoms will remain intact to provide a basis for analyzing material flow.)

The units are identical for each term in the equation. If 'mass in' has units of kg then 'mass out' and all other terms must also be kg. Form the habit of checking units before calculating.



**Figure 4.1** The mass entering a region must equal the mass leaving (left side) unless mass is accumulated or destroyed with the region (right). The same units must be used to measure all quantities in the material balance.

If no chemical reaction creates or destroys a particular species, the conservation of that species is

$$\left[ \begin{array}{c} \text{total mass of} \\ \text{species } i \text{ in} \end{array} \right] - \left[ \begin{array}{c} \text{total mass of} \\ \text{species } i \text{ out} \end{array} \right] = \left[ \begin{array}{c} \text{accumulation of mass} \\ \text{of species } i \text{ in the region} \end{array} \right]$$

Accumulation can be positive or negative; it is negative if there is a decrease of mass within the region.

Conservation of mass applies to every natural and constructed system and the material balance is the most important tool for analyzing these systems. In this chapter you will see it used on air pollution, water and wastewater treatment, and solid waste processing. Try to understand what the processes do and remember the terminology. In this way you will learn a good deal about pollution control while you master making material balances.

**Example 4.1 SOLVENT LOSS IN A PAINT SPRAY BOOTH**

Unpainted metal parts enter a spray-painting booth at a rate of 300 kg/h, where they are sprayed with a solvent based paint. Paint usage is 10 kg/h and the paint is 50% solvent and 50% solid pigment. The dry painted parts leave the booth at a rate of 304 kg/hr. Assume that all solvent has evaporated from the adhered paint when the part leaves the spray booth. A portion of the paint pigment adheres to the metal parts, but some is wasted. Solvent is lost by evaporation and with paint droplets that did not adhere to the parts.

The first step is to show on a diagram, Figure 4.2, what is known about the problem.



**Figure 4.2** Paint spray booth material balance

Overall material balance: Clean Parts + Paint = Dry Painted Parts + Waste Paint  
300 kg/h + 10 kg/h = 304 kg/h + 6 kg/h Waste

Solvent material balance: Solvent In = Waste Solvent  
5 kg/h = 5 kg/h

Pigment material balance: Pigment In = Pigment on painted parts + Waste Pigment  
5 kg/h = 4 kg/h + 1 kg/h

This simple calculation is useful in making a plan to reduce paint waste and solvent emissions. The amount of solvent lost as waste in this process could be reduced by using (1) water-based paint, (2) solvent-base paint with a higher pigment content, or (3) solid-deposition painting. The lose of pigment lost could be reduced by using a more focused spray or solid-deposition painting.

It is often convenient to deal with mass flow rates, such as kg/h or T/d. The conservation laws then take on these special forms.

$$\left[ \begin{array}{c} \text{total rate of} \\ \text{mass inflow} \end{array} \right] - \left[ \begin{array}{c} \text{total rate of} \\ \text{mass outflow} \end{array} \right] = \left[ \begin{array}{c} \text{rate of accumulation} \\ \text{mass in the region} \end{array} \right]$$

$$\left[ \begin{array}{c} \text{total rate of} \\ \text{inflow of species } i \end{array} \right] - \left[ \begin{array}{c} \text{total rate of} \\ \text{outflow of species } i \end{array} \right] = \left[ \begin{array}{c} \text{rate of accumulation} \\ \text{of species } i \text{ in the region} \end{array} \right]$$

*Steady state* is the special case when the rate of accumulation is zero. The sum of the inputs equals the sum of the outputs. The rate of material inflow and outflow from the system are not changing with time. The volume of liquid or gas in any process vessels is constant.

Steady state conditions can often be assumed over some time period of interest. This is a great convenience, but it is not a cheat or a short cut. Making a steady state analysis for average load, minimum load, and peak load often provides a sound basis for design. The assumption also reduces the amount of information that is needed, information that usually is lacking during preliminary design.

**gaiteye**  
Challenge the way we run

**EXPERIENCE THE POWER OF  
FULL ENGAGEMENT...**

**RUN FASTER.  
RUN LONGER..  
RUN EASIER...**

**READ MORE & PRE-ORDER TODAY  
WWW.GAITEYE.COM**

## 4.2 Accumulation of Mass

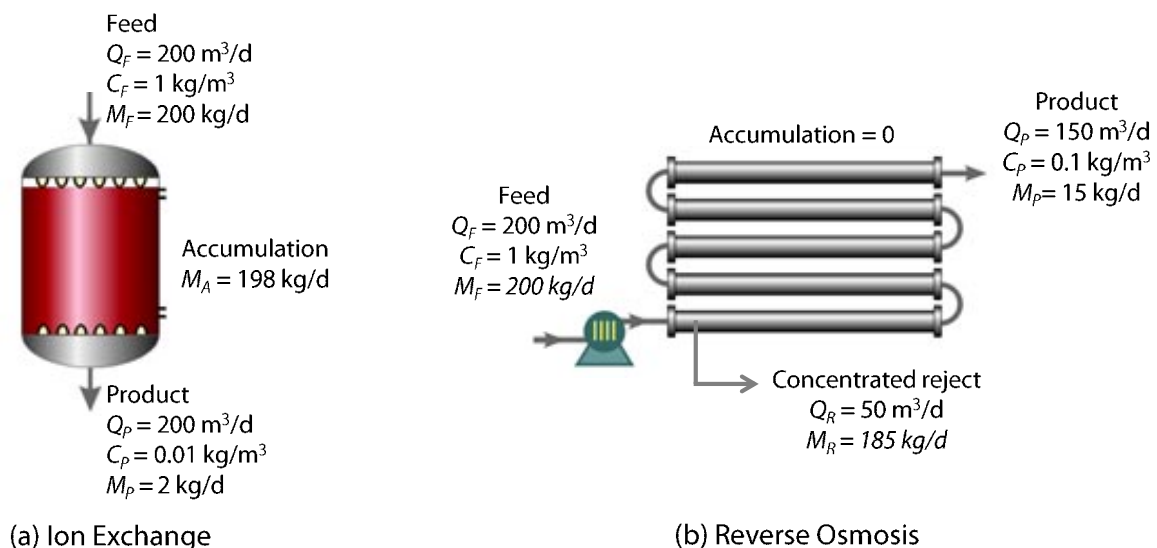
A process that accumulates material can only do so temporarily so positive accumulation must be followed by a period of negative accumulation. Allowing solids to accumulate in the bottom of a settling tank will eventually reduce the efficiency, so the solids must be removed at regular intervals.

The material balance on a process or system that accumulates material will have two parts, one for the accumulation phase and one for the cleaning/regeneration phase. These two can be added to get the overall material balance for one operating cycle.

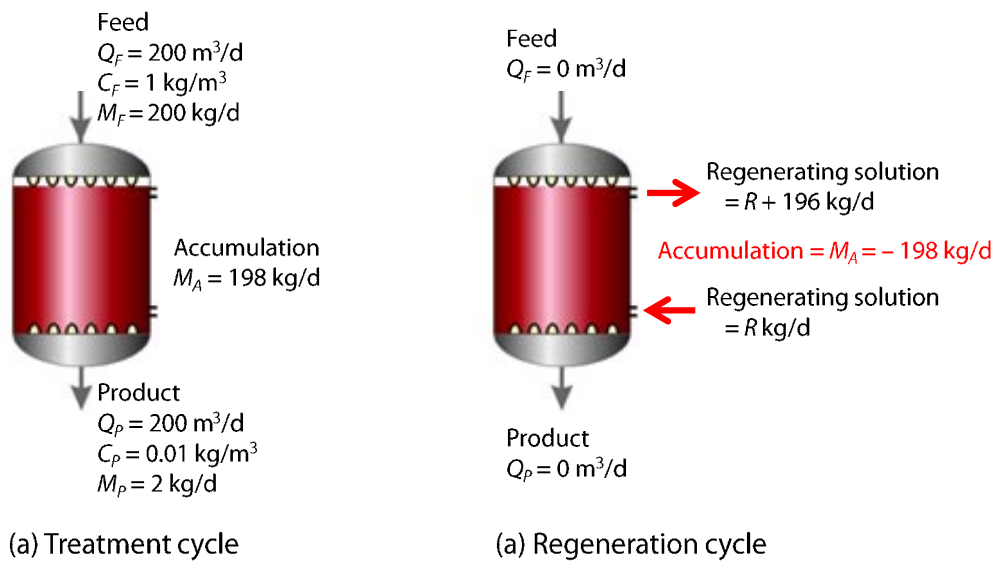
Figure 4.3(a) shows an ion exchange process for making high-purity water. Salts and minerals are absorbed by resin and replaced by hydrogen ions ( $H^+$ ) and hydroxyl ions ( $OH^-$ ) that combine to form water. The feed is water plus dissolved salts; the product water is nearly salt-free. Salts accumulate in the ion exchanger.

Figure 4.3(b) is a reverse osmosis process that splits the feed into a high-quality product and concentrated reject stream. The flow of water and salts is continuous and at steady state. There is no accumulation of salts or water within the system.

Figure 4.4 shows the complete operating cycle for the ion exchange process. The operating cycle is shown as one day, which perhaps is a 23-hour production cycle, with salt accumulation, and 1-hour regeneration cycle. At the end of the production cycle the ion exchange resin will be exhausted of its capacity to exchange salts and it will be regenerated back to its original capacity.



**Figure 4.3** (a) Ion exchange process that accumulates salts but not water.  
(b) Reverse osmosis process that does not accumulate salts or water.



**Figure 4.4** One operating cycle for the ion exchange process includes production, with salt accumulation, and regeneration, which removes the accumulate salts.

Many waste treatment processes temporarily accumulate material within the system. Water filters, air filters, activated carbon adsorption, and ion exchange resins are examples. These processes operate on an alternating cycle of accumulation followed by cleaning or regeneration. Water filters are cleaned by backwashing, typically once a day, to remove the accumulated solids. Air filters are cleaned more frequently by a reverse pulse of air or by shaking. Ion exchange resins are regenerated by flushing with a strong chemical solution (brine or acid or base). Carbon from adsorption processes can be regenerated using steam if the adsorbed chemicals are volatile, or by thermal heat if they are not.

### 4.3 Style in Material Balance Formulation

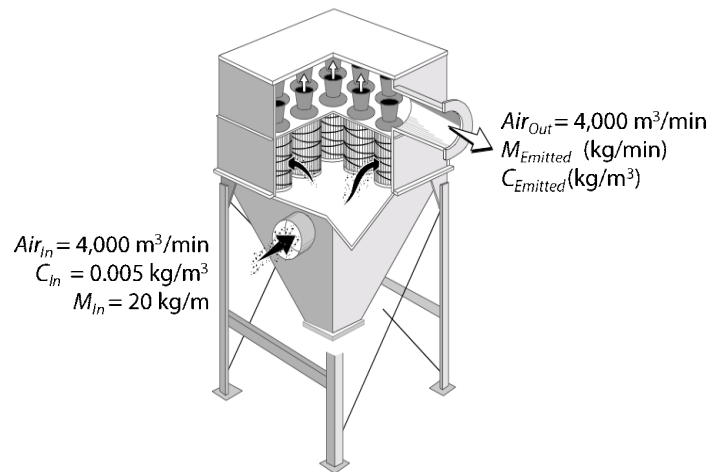
Five guidelines in developing the material balance are:

1. Draw a *block diagram* or *flow sheet* for the problem and show all known quantities and streams. Pressures, temperatures, and the like do not need to be shown.
2. Decide on the *basis* for solving the problem, for example, a time interval of one day, or an input of 1000 kg.
3. Identify *tie components*. A tie component is an element, molecule, or kind of material that goes through the process unchanged. Dry air, water, or an inert solid are good choices as a tie component.
4. Select the *boundaries* of the region over which the material balance will be made. The law of conservation of mass applies to any and all regions so we are free to try and choose boundaries crossed only by one unknown flow to simplify the work.
5. Write the *material balance equations* and check the units. Each term of the equation must have the same units.

Chapter 5 will deal with some additional issues about style, in particular the structure of systems of equations, solving simultaneous equations and iterative solutions, and some strategies for choosing which variables the designer will manipulate when there is a choice.

**Example 4.2 AIR EMISSION TEST**

During an air emission test, the inlet gas stream to a fabric filter (Figure 4.5) is 4,000 standard m<sup>3</sup>/min and the particulate loading of dust is 0.005 kg/m<sup>3</sup>. The particulate removal efficiency is 99.25%. Compute the dust concentration in the emitted air and the mass of dust removed by the filter. The volume of air removed with the collected dust is negligible.



**Figure 4.5** Dust collection emission test

Basis = 1 minute = 4,000 m<sup>3</sup>/min air  
Tie component = dust (assumed to be inert)  
Boundary = Fabric filter equipment

Mass flow of dust into the filter  
 $M_{in} = (4,000 \text{ m}^3/\text{min})(0.005 \text{ kg/m}^3) = 20 \text{ kg/m}$

Material balance on dust solids

$$(4,000 \text{ m}^3/\text{min})(0.005 \text{ kg/m}^3) = M_{Emitted} + (0.9925)(4,000 \text{ m}^3/\text{min})(0.005 \text{ kg/m}^3)$$

*Dust In* *Dust Removed*

$$M_{Emitted} = M_{in} - M_{Removed} = 20.00 - 19.85 = 0.15 \text{ kg/min}$$

$$C_{Emitted} = (0.15 \text{ kg/m}) / (4,000 \text{ m}^3/\text{min}) = 0.0000375 \text{ kg/m}^3 = 37.5 \text{ mg/m}^3$$

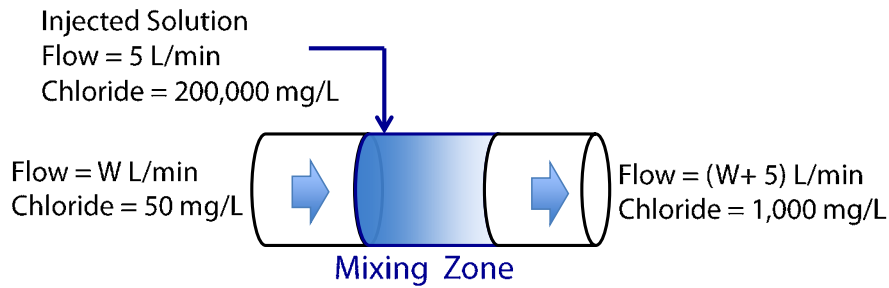
$$M_{removed} = 20.00 - 0.15 = 19.85 \text{ kg/min}$$



**Example 4.3 SALT TRACER MEASUREMENT OF FLOW**

Flow will be measured by adding a known mass of inert tracer, such as chloride or lithium, because it is not possible to install a conventional flow meter in a pipe. The tracer concentration is measured after it has mixed with the flow in the pipe. The mixing zone is shown in Figure 4.6. Chloride concentration above the injection point is 50 mg/L.

Chloride solution at 200,000 mg/L concentration (20% by weight) is added at a rate of 5 L/m. The concentration measured downstream is 1000 mg/L. There is no accumulation of chloride or water within the mixing zone.



**Figure 4.6** Diagram of flow measurement by tracer dilution.

Basis = 1 min

The tie component is chloride

Boundary = mixing zone

Material balance on water:

$$\text{Water In (L/min)} = \text{Water Out (L/min)} = W \text{ L/min} + 5 \text{ L/min}$$

Material balance for chloride, with units of mg/min:

$$\underbrace{(W \text{ L/min})(50 \text{ mg/L})}_{\text{chloride from upstream}} + \underbrace{(5 \text{ L/min})(200,000 \text{ mg/L})}_{\text{chloride added}} = \underbrace{(W + 5 \text{ L/min})(1000 \text{ mg/L})}_{\text{chloride leaving downstream}}$$

$$50W + 1,000,000 = 1000W + 5000$$

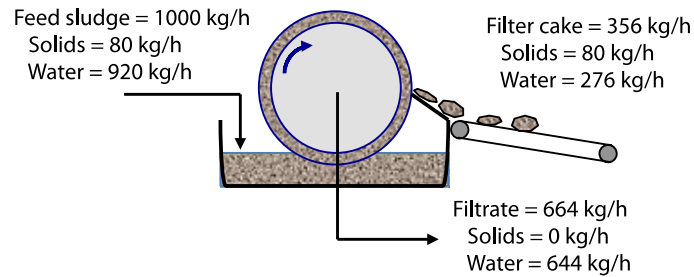
$$(950 \text{ mg/L}) (W \text{ L/min}) = 995,000 \text{ mg/m}$$

$$W = 1,047 \text{ L/min (270.2 gpm = 0.3891 mgd)}$$

The precision of this value is misleading because the chloride concentrations cannot be measured exactly. The reported concentration could be in error by  $\pm 5\%$ . The tracer injection rate may not be a constant 5 L/m. Let us say, as a practical estimate, that the flow is 1,050 L/m. Repeated measurements should be made if greater accuracy is required.

**Example 4.4 SLUDGE DEWATERING**

A vacuum filter, Figure 4.7, removes water from sludge or slurry. The input sludge is 8% solids by weight. Seventy percent of the water in the feed sludge is removed as filtrate, which will be assumed free of solids. All the feed solids and 30% of the water in the feed sludge leave as a filter cake.



**Figure 4.7** Vacuum filter removes water from sludge.

Basis: 1000 kg feed sludge  
Tie component = water or solids  
Boundary = vacuum filter equipment

Material balance on water:  
Water in feed = Filtrate + Water in filter cake  
1000 kg of feed sludge contains  $(0.92)(1000) = 920$  kg of water

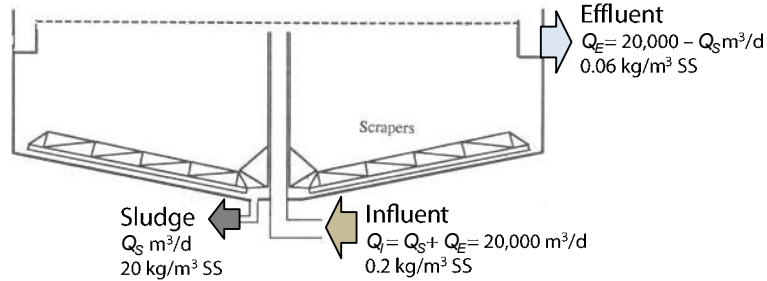
Water in filtrate =  $0.7(920 \text{ kg}) = 644$  kg  
Volume of filtrate =  $0.644 \text{ m}^3/\text{ton}$  of sludge processed.  
Water in the filter cake =  $920 \text{ kg} - 644 \text{ kg} = 276$  kg

Material balance on solids:  
Solids in feed = Solids in filtrate + Solids in filter cake  
1000 kg of feed sludge contains  $(0.08)(1000) = 80$  kg solids

Filter cake contains 80 kg solids and 276 kg water.  
Total mass of sludge cake =  $80 \text{ kg solids} + 276 \text{ kg water} = 356$  kg  
Moisture content =  $100(276/356) = 77.5\%$   
Solids content =  $100(80/356) = 22.5\%$

**EXAMPLE 4.5 SOLIDS REMOVAL IN A SETTLING TANK**

The influent to a wastewater settling tank (Figure 4.8) is 20,000 m<sup>3</sup>/d at a concentration of 200 mg/L (0.2 kg/m<sup>3</sup>) of suspended solids and the effluent contains 60 mg/L. The sludge that is drawn off the bottom of the tank has a solids concentration of 20,000 mg/L (20 kg/m<sup>3</sup>). Calculate the sludge removal rate as a percentage of the inflow.



**Figure 4.8** Wastewater settling tank with center feed and peripheral effluent removal.

Basis = 1 day = 20,000 m<sup>3</sup>/d

Tie component = suspended solids

Boundary = settling tank

Material balance on water

$$Q_i = 20,000 \text{ m}^3/\text{d} = Q_s + Q_e$$

Material balance on solids gives the sludge flow

$$(20,000 \text{ m}^3/\text{d})(0.2 \text{ kg/m}^3) = (Q_s)(20 \text{ kg/m}^3) + (Q_i - Q_s)(0.06 \text{ kg/m}^3)$$

*influent*                      *sludge*                      *effluent*

$$Q_s = 140.4 \text{ m}^3/\text{d}$$

$$\text{Sludge removal rate (\%)} = 100(140.4 \text{ m}^3/\text{d})/(20,000 \text{ m}^3/\text{d}) = 0.7\% \text{ of influent}$$

Material balance on solids

$$(20,000 \text{ m}^3/\text{d})(0.2 \text{ kg/m}^3) = (140.4)(20 \text{ kg/m}^3) + (20,000 - 140.4)(0.06 \text{ kg/m}^3)$$

*influent*                      *sludge*                      *effluent*

$$4,000 \text{ kg/d} = 2,808 \text{ kg/d} + 1,192 \text{ kg/d}$$

**Example 4.6 SLUDGE PROCESSING SYSTEM**

Sludge from a settling tank, which is 2% solids by weight, is thickened to 4.5% solids. The thickener supernatant contains 5% of the thickener influent solids. The thickened sludge is dewatered in a vacuum filter. The filter cake produced by the vacuum filter is 22% solids by weight and the filtrate contains 5% of the filter feed solids. The filter cake is dried to 5% moisture. The material balance is shown in Figure 4.9.

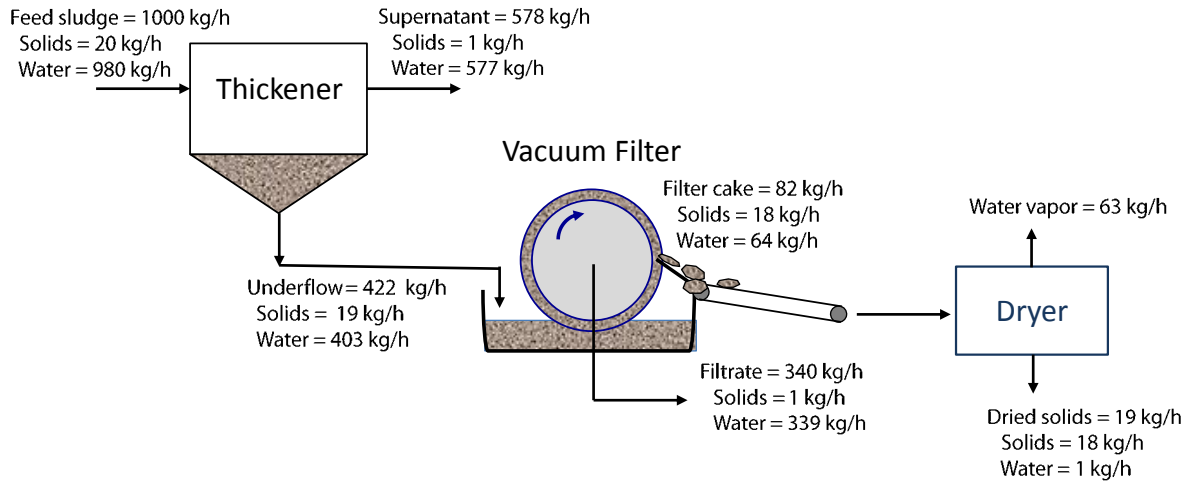
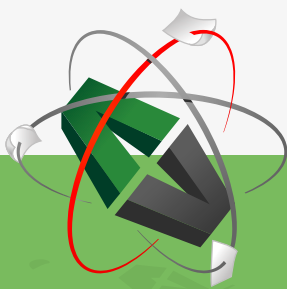


Figure 4.9 Sludge processing system

This e-book  
is made with  
**SetaPDF**



PDF components for PHP developers

[www.setasign.com](http://www.setasign.com)



Click on the ad to read more

#### 4.4 Checking the Material Balance for Accuracy

The previous examples use the material balance to determine one or more quantities that have not been measured or specified. Another situation is when all inputs and outputs have been measured and a check can be made that the material balance is satisfied. This is a way to verify that measurements are being made with sufficient accuracy, that sampling procedures are correct, and that all input and output streams are included.

##### Example 4.7 TWO-STAGE MEMBRANE SEPERATION SYSTEM

Figure 4.10 shows a two-stage process that converts a feed into two products and a reject stream. It doesn't matter what the material is, but for convenience assume it is total solids.

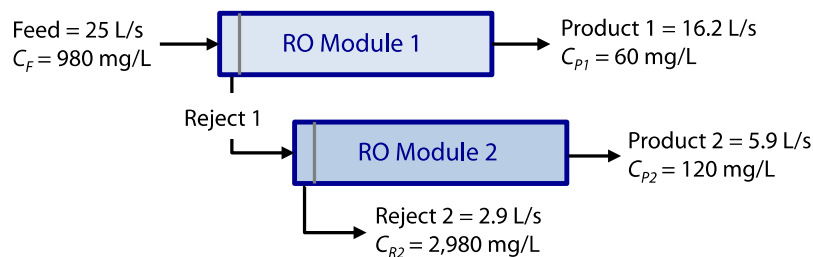


Figure 4.10 A two-stage process with all inputs and outputs measured.

Overall material balance on Flow

$$25 \text{ L/s} = 16.2 \text{ L/s} + 5.9 \text{ L/s} + 2.9 \text{ L/s}$$

*Feed    Product 1    Product 2    Reject 2*

Overall material balance on Total solids

$$(25 \text{ L/s})(980 \text{ mg/L}) = (16.2 \text{ L/s})(60 \text{ mg/L}) + (5.9 \text{ L/s})(120 \text{ mg/L}) + (2.9 \text{ L/s})(2,980 \text{ mg/L}) \pm \text{Error}$$

*Feed                    Product 1                    Product 2                    Reject 2*

$$24,500 \text{ mg/s} = 972 \text{ mg/s} + 708 \text{ mg/s} + 8,642 \text{ mg/s} \pm \text{Error}$$

$$24,500 \text{ mg/s} = 10,322 \text{ mg/s} \pm \text{Error}$$

$$\text{Error} = 14,178 \text{ mg/s}$$

The imbalance is too large to be explained by random measurement error in the total solids concentrations, which might reasonably be  $\pm 5\%$ . Possibly the reject concentration is in error.

The material balance on module 1 gives

$$\text{Mass of solids into module 2} = (25)(980) - (16.2)(60) = 23,528 \text{ mg/s}$$

*Feed1                    Product 1                    Reject 1*

Assuming this is correct and Product 2 is correct, the reject from module 2 should be

$$\text{Reject 2} = 23,528 \text{ mg/s} - (5.9 \text{ L/s})(120 \text{ mg/L}) = 22,820 \text{ mg/s}$$

$$\text{Reject 2 concentration} = (22,820 \text{ mg/s}) / (2.9 \text{ L/s}) = 7,869 \text{ mg/L}$$

Perhaps the measured value was 7,980 mg/L and the person who made the drawing mistakenly put down 2,980 mg/L. Or there may be a problem with totals solids measurements. Either way, more work is needed to quantify the process.

**Example 4.8 RECYCLE TO A PRIMARY SETTLING TANK FOR WASTEWATER TREATMENT**

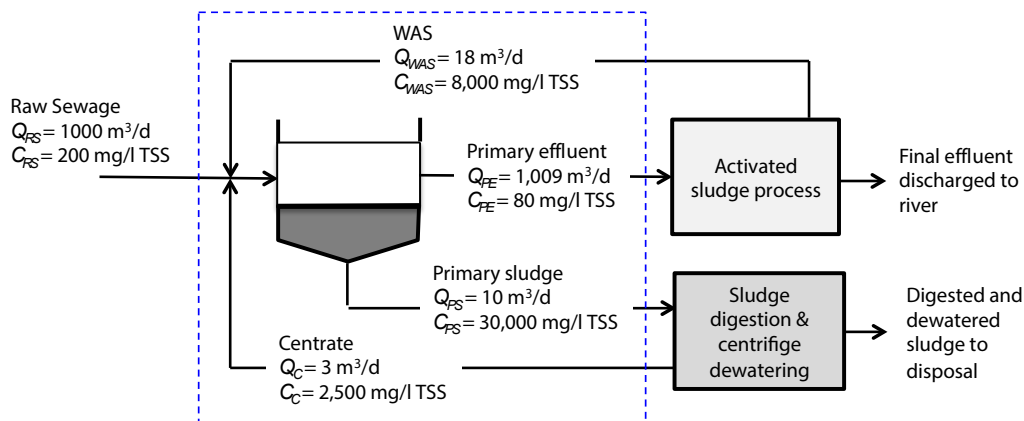
A primary clarifier in a wastewater treatment plant receives raw sewage (RS), waste activated sludge (WAS), and centrate (C) from a sludge dewatering centrifuge. WAS is waste activated sludge, which is intentionally removed from the activated sludge process to balance the new biomass that is produced by the treatment process. Centrate is the dilute effluent from a centrifuge that is used to dewater digested sludge. Primary effluent (PE) and primary sludge (PS) are removed from the clarifier. Figure 4.11 shows the process and data measured on the process are given below. The operator has used these data to make a check on the mass balance. The solids concentrations in the calculations are kg/m<sup>3</sup>.

$$\begin{aligned} \text{Solids In} &= Q_{RS}C_{RS} + Q_C C_C + Q_{WAS}C_{WAS} \\ &= 1000(0.2) + 18(8) + 3(2.5) = 351.5 \text{ kg/d} \end{aligned}$$

$$\begin{aligned} Q_{PE} &= (Q_{RS} + Q_C Q_{WAS}) - Q_{PS} \\ &= 1000 \text{ m}^3/\text{d} + 16 \text{ m}^3/\text{d} + 3 \text{ m}^3/\text{d} - 10 \text{ m}^3/\text{d} = 1,009 \text{ m}^3/\text{d} \end{aligned}$$

$$\begin{aligned} \text{Solids Out} &= Q_{PE}C_{PE} + Q_{PS}C_{PS} \\ &= 1,009(0.08) + 10(30) = 80.7 + 300 = 380.7 \text{ kg/d} \end{aligned}$$

The solids in and solids out agree within ±10%. This is good closure on the material balance and the measurements seems to be reliable.



**Figure 4.11** Primary settling tank receiving recycle centrate from a sludge dewatering centrifuge and waste activated sludge recycle.

#### 4.5 Application – Desalting Water by Reverse Osmosis

A city needs water with a salt concentration of 500 mg/L for drinking and normal household use but it must take its water from a brackish source that has a salt concentration of 10,000 mg/L. Salt refers to all the dissolved minerals in the water.

A flow of 10 L/s of brackish water will enter the desalting system (reverse osmosis, or RO). A portion will be treated to reduce the salt concentration to 100 mg/L and this will be blended with untreated water to produce a mixture having a salt concentration of 500 mg/L. An input of X L/s brackish water yields 0.75X L/s of water at 100 mg/L and 0.25X L/s of brine that is useless. Figure 4.12 shows the water treatment system and all known flows and concentrations.



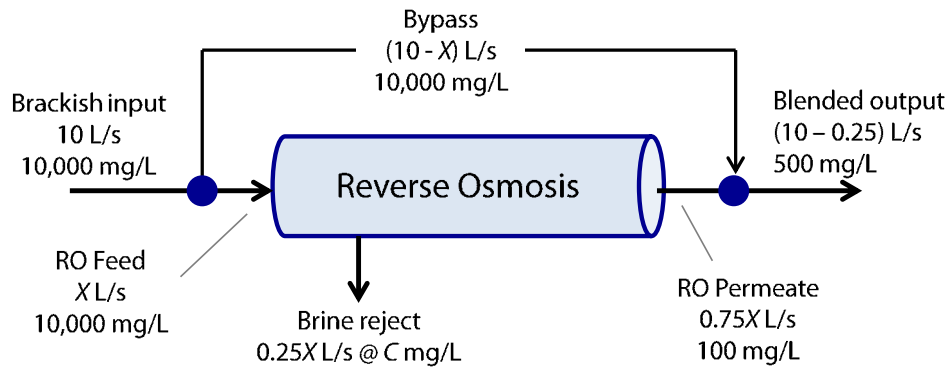


Figure 4.12 Material balance on a reverse osmosis desalting system.

Basis = 10 L/s.

Tie Component = Salt

*Boundaries.* The law of conservation of mass applies to each element of the system, and to the entire system so we have more than one way to define the regions over which to make the material balances. Sometimes more than one region must be used to complete a problem. The four possible regions are defined in Figure 4.13.

www.sylvania.com

We do not reinvent the wheel we reinvent light.

Fascinating lighting offers an infinite spectrum of possibilities: Innovative technologies and new markets provide both opportunities and challenges. An environment in which your expertise is in high demand. Enjoy the supportive working atmosphere within our global group and benefit from international career paths. Implement sustainable ideas in close cooperation with other specialists and contribute to influencing our future. Come and join us in reinventing light every day.

Light is OSRAM

OSRAM SYLVANIA

Click on the ad to read more

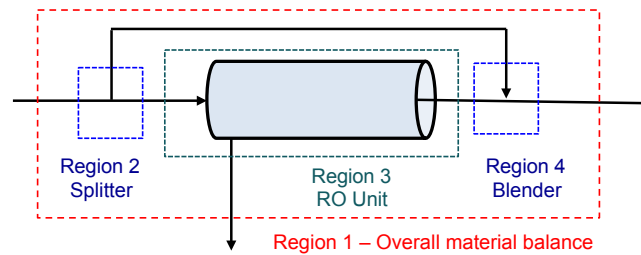


Figure 4.13 Selection of region over which to make the material balance.

Material balance equations. The four possible material balance equations for salt are:

$$\begin{aligned}
 \text{Region 1:} \quad & 10(10000) = (10 - 0.25X)(500) + (0.25 X)C \\
 \text{Region 2:} \quad & 10(10000) = 10000 X + (10 - X)(10000) \\
 \text{Region 3:} \quad & 10000 X = (0.25 X) C + (0.75X) (100) \\
 \text{Region 4:} \quad & (10 - X)(10000) + 0.75 X(100) = (10-0.25X)(500)
 \end{aligned}$$

There are  $M = 2$  unknowns so  $N = 2$  equations are needed to solve the problem. The material balance equation for Region 2 is an identity and provides no useful information. One of the other equations is redundant. For example, adding the material balances on regions 2, 3 and 4 gives the overall material balance equation for Region 1.

In this example, the material balances on Region 1 and Region 3 involve both the unknowns,  $X$  and  $C$ . These two equations could be solved simultaneously. There is an easier way because the equation for Region 4 has only one unknown quantity,  $X$ , and can be solved directly.

$$\begin{aligned}
 (10 - X \text{ L/s})(10,000 \text{ mg/L}) &+ (0.75X \text{ L/s})(100 \text{ mg/L}) = (10 - 0.25X \text{ L/s})(500 \text{ mg/L}) \\
 \text{bypass into blender} & \qquad \qquad \text{RO effluent into blender} & \qquad \qquad \text{output from blender}
 \end{aligned}$$

$$X = 9.69 \text{ L/s}$$

The other flows are:

$$\begin{aligned}
 \text{Flow into RO unit} &= 9.69 \text{ L/s} \\
 \text{Bypass flow} &= 10 - 9.69 = 0.31 \text{ L/s} \\
 \text{RO desalted effluent} &= 0.75(9.69) = 7.27 \text{ L/s} \\
 \text{Brine reject} &= 0.25(9.69) = 2.42 \text{ L/s} & \qquad \qquad \text{(also } 9.69 - 7.27 = 2.42 \text{ L/s)} \\
 \text{Blended product water} &= 7.27 + 0.31 = 7.58 \text{ L/s} & \qquad \qquad \text{(also } 10.0 - 2.42 = 7.58 \text{ L/s)}
 \end{aligned}$$

The material balance for salt on the RO module (region 3) is

$$\begin{aligned}
 \text{Mass of salt in the brine} &= 96.9 - 0.727 = 96.2 \text{ g/s} \\
 \text{Concentration of salt in the brine} &= C = (96.2 \text{ g/s}) / (2.42 \text{ L/s}) = 39,800 \text{ mg/L}
 \end{aligned}$$

Figure 4.14 shows the completed material balance.

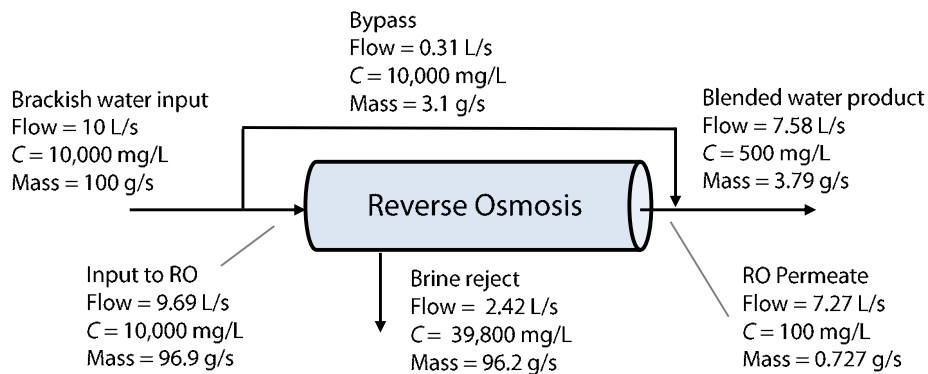


Figure 4.14 Expanded information diagram for the reverse osmosis problem.

#### 4.6 Application – Drying Sludge with Warm Air

Wet sludge will be dried by contacting it with hot dry air. Part of the humid air leaving the dryer will be recycled through a heater and bone-dry air will be added as make-up for the humid air removed. The sludge is initially 30% water and 70% solids. It will be dried to 10% water. Calculate the amount of air brought into the drying system if the humid air stream is 5% water by weight (Rudd et al. 1973).

Figure 4.15 shows what is initially known about the flow of dry solids, air, and water. Figure 4.16 shows the solution.

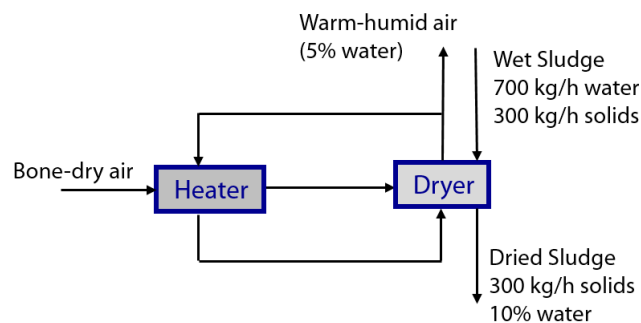


Figure 4.15 Sludge drying problem definition (adapted from Rudd et al 1973)

Basis = 1000 kg/h sludge input = 700 kg/h water + 300 kg/h solids

Tie component = 300 kg/h dry solids

Mass flow of water in dried sludge

Dried sludge output =  $S = 300 \text{ kg/h solids} + W \text{ kg/h water}$

Specification:  $S$  is 10% water and 90% solids.

$W = 0.1S$

$W \text{ kg/h water} = 0.1(300 \text{ kg/h solids} + W \text{ kg/h water})$

$W = 300(0.1)/0.9 = 33 \text{ kg/h water}$

Overall material balance on water

$$\text{Water in air} = 700 - 33 = 667 \text{ kg/h}$$

Specification: humid air is 5% water

$$667 \text{ kg/h water} = 0.05(A \text{ kg/h bone-dry air} + 667 \text{ kg/h water})$$

$$A = 667(0.95)/0.05 = 12,700 \text{ kg/h bone-dry air}$$

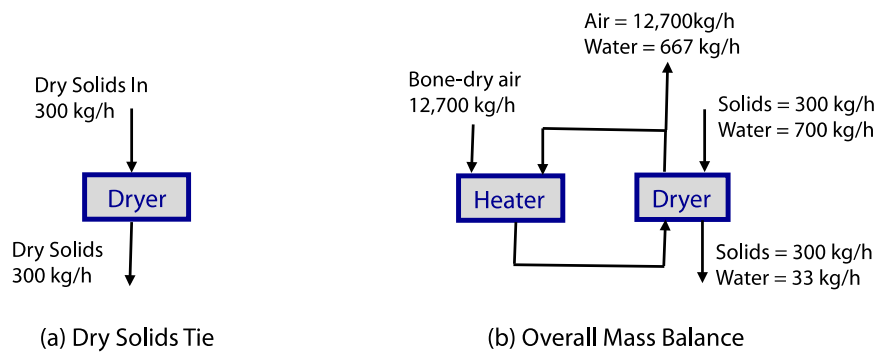


Figure 4.16 Sludge drying material balances



Discover the truth at [www.deloitte.ca/careers](http://www.deloitte.ca/careers)

**Deloitte.**

© Deloitte & Touche LLP and affiliated entities.



## 4.7 Application – Boiler Blowdown

Feed water enters the boiler; steam and blowdown exit. The blowdown depends on steam consumption (steam not returned as condensate to the boiler), the concentration of impurities in the feed water, and the maximum allowable TDS in the boiler.

The blowdown rate calculation is a material balance problem, as shown in Figure 4.17. The total dissolved solids (TDS) in the circulating boiler water must be maintained below a specified level by removing salts in the blowdown, which has a flow rate of  $Q_{BD}$  and a total dissolved solids concentration  $TDS_{BD}$ . Feed water is added to the system to makeup the water lost as steam and blowdown.

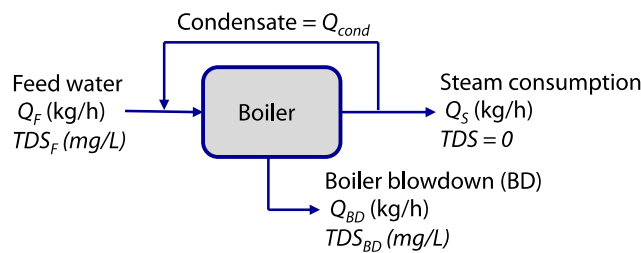


Figure 4.17 Material diagram for boiler blowdown

The material balances on water and total dissolved solids are

$$Q_F = Q_{BD} + Q_S$$

$$Q_F TDS_F = Q_{BD} TDS_{BD} + Q_S (0 \text{ mg/L})$$

The boiler blowdown rate is

$$Q_{BD} = \frac{Q_S TDS_F}{TDS_{BD} - TDS_F}$$

where  $Q_F$  = feed water rate (makeup) (kg/h)

$Q_{BD}$  = blowdown rate (kg/h)

$Q_S$  = steam consumption (kg/h)

$TDS_F$  = Total Dissolved Solids in the feed water (ppm)

$TDS_{BD}$  = Total Dissolved Solids in the boiler blowdown

= maximum allowable TDS in the boiler water (ppm)

The cycles of concentration is

$$\text{Cycles of concentration} = \frac{TDS_{BD}}{TDS_F}$$

The concentration of a specific ion can replace TDS in this formula. Chloride is commonly used. Or, conductivity can be used as a surrogate for total dissolved solids.

**Example 4.9 BOILER BLOWDOWN**

A boiler system is to be controlled so the total dissolved solids in the blowdown does not exceed  $TDS_{BD} = 2000$  mg/L for a feed water (makeup) that has  $TDS_f = 200$  mg/L TDS. Steam consumption,  $Q_s$ , is 1000 kg/d. The blowdown is

$$Q_{BD} = \frac{Q_s TDS_f}{TDS_{BD} - TDS_f} = \frac{(1,000\text{kg/d})(200\text{mg/L})}{(2,000\text{mg/L} - 200\text{mg/L})} = 111\text{kg/d}$$

**Example 4.10 CYCLES OF CONCENTRATION OF BOILER WATER**

The chloride content of a boiler water is 190 mg/L (ppm) and the chloride content of the feed water is 40 mg/L (ppm). The cycles of concentration is

$$\text{Cycles} = 190/40 = 4.75$$

Note: The cycles of concentration for the boiler in Example 4.9 is

$$\text{Cycles} = 2000/200 = 10$$

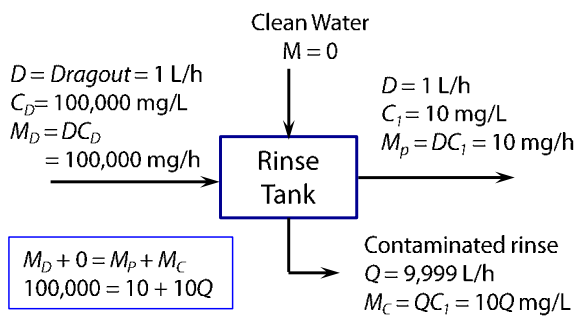
## 4.8 Application – Water Conservation in Rinsing Operations

Rinsing and cleaning operations can provide excellent opportunities to save water and, at the same time, concentrate wastewater streams so material recovery is more feasible.

Parts leaving a plating bath must be rinsed clean before going to the next manufacturing step. The racks that carry the parts are coated with residual acid and metal solution that is called *drag-out*. The volume of drag out is a function of the shape of the parts, drain time, and plating bath viscosity. The used rinse water is contaminated so efficient rinsing is often part of a pollution prevention program.

An engineer doing a plant walk-through sees the single-stage rinsing scheme shown in Figure 4.18. The concentration carried on the parts and racks (Figure 4.18b) as drag-out is 100,000 mg/L. This needs to be reduced to 10 mg/L by rinsing. The 1 L/h drag-out has to be diluted 10,000 times (actually 9,999 times). The input of clean water for rinsing is 10,000 L/h. The 10,000 L/h output of slightly contaminated rinse water has a concentration of 10 mg/L.





(a) Material balance for a single-stage rinse.

(b) Electroplated parts on a rack are moved from one bath to the next.

Figure 4.18 Single-stage rinsing.

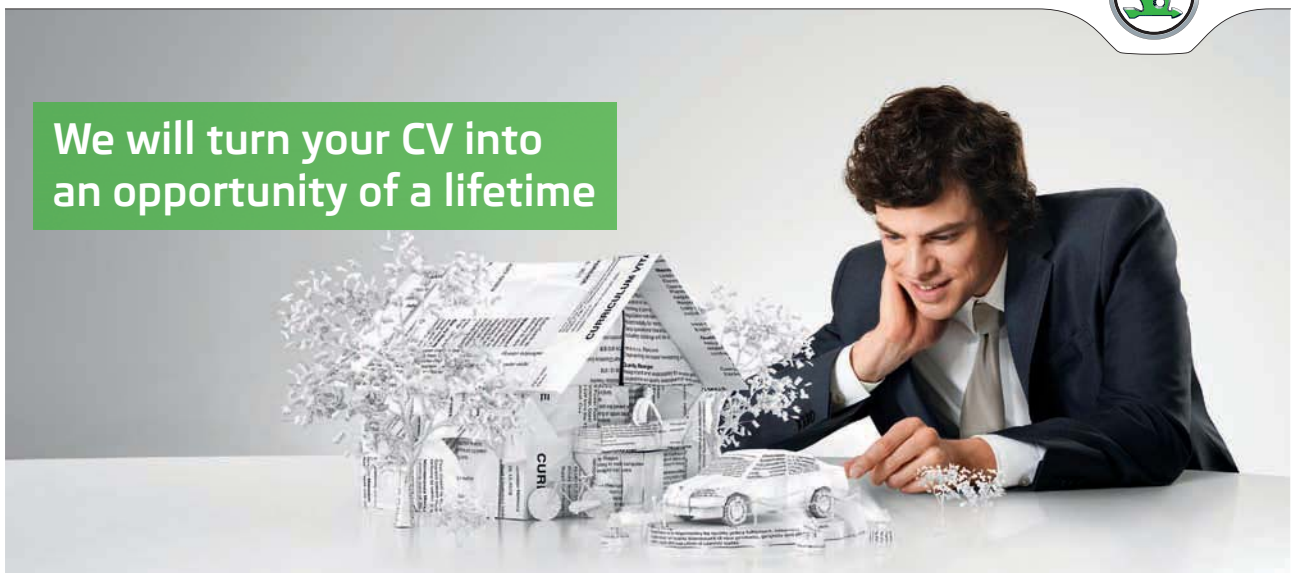
The engineer notices a vacant space where another rinse tank might fit and starts to think of new arrangements. One possibility is to add a drip tank so the parts rack could be drained before going to rinsing.

SIMPLY CLEVER

ŠKODA



We will turn your CV into  
an opportunity of a lifetime



Do you like cars? Would you like to be a part of a successful brand?  
We will appreciate and reward both your enthusiasm and talent.  
Send us your CV. You will be surprised where it can take you.

Send us your CV on  
[www.employerforlife.com](http://www.employerforlife.com)



Click on the ad to read more

Another possibility is to dip the part racks into a dead-rinse tank before additional rinsing, as shown in Figure 4.19. The water in the dead-tank will be clean initially but would become contaminated over time. A rough calculation shows that a 100 L dead-tank would have a concentration of 20,000 mg/L after 24 hours of use. The lower dragout concentration coming from the dead-rinse allows the amount of rinse water to be reduced from 10,000 L/h to the amounts estimated in the graph of  $Q$  versus time. When the dead tank needs to be refreshed with clean water, its contents could be recycled to the plating tanks, to make up water lost from drag-out and evaporation.

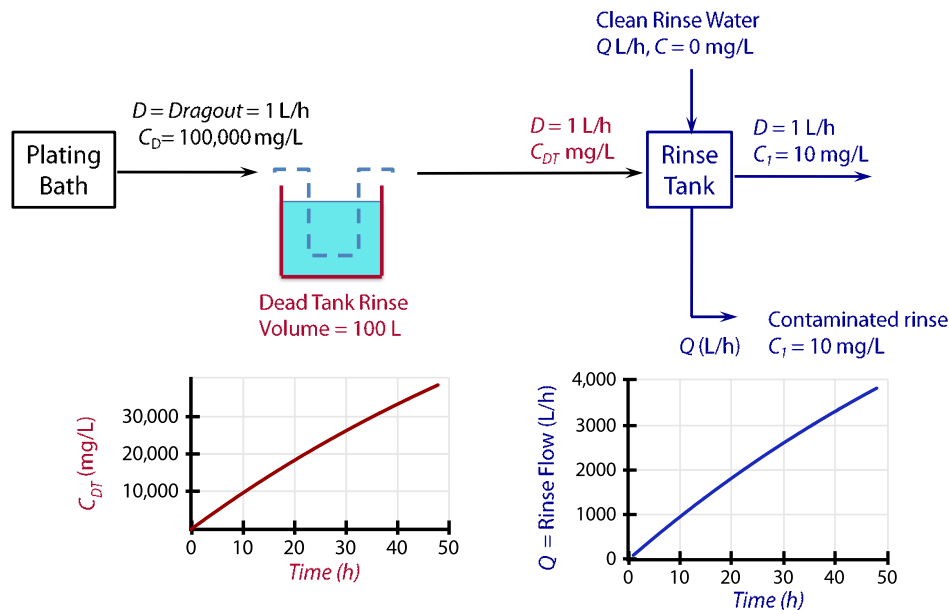


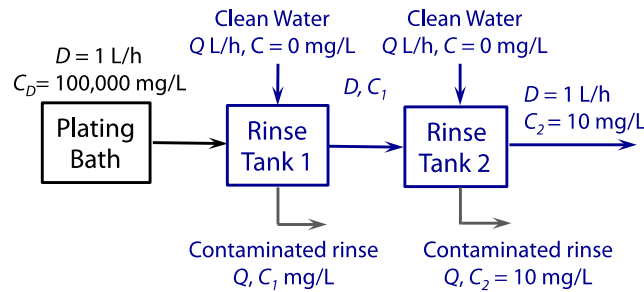
Figure 4.19 Dead Rinse tank preceding a single-stage rinse.

Other options include spray rinses over the plating tanks (the spray rate would have to be less than the evaporation rate so the tanks would not overflow) and air jets to blow off the drag-out. If the drag-out going to the rinses could be reduced from 1 L/h to 0.1 L/h, the rinse water flow would be reduced from 10,000 L/h to 1,000 L/h. Certainly one of these ideas, or a combination, could be used to improve the rinse efficiency.

Another strategy is staged rinsing. A two-stage rinse will be more efficient than a single-stage rinse, and a countercurrent process will be more efficient than a crossflow process. Countercurrent processing is used in many situations, including this one.

**Example 4.11 TWO-STAGE CROSSFLOW RINSE**

Figure 4.20 shows a two-stage crossflow rinsing system. The drag-out and rinse water leaving rinse bath 2 must have concentration  $C_2 = 10 \text{ mg/L}$ . The concentration  $C_1$  is unknown. Equal flow to each stage will minimize the total water use.



**Figure 4.20** Two-stage crossflow rinsing system

The material balance equations are:

$$\begin{aligned} \text{Rinse bath 1:} \quad & (1 \text{ L/h})(100,000 \text{ mg/L}) + 0 = (1 \text{ L/h}) C_1 + Q C_1 \\ \text{Rinse bath 2:} \quad & (1 \text{ L/h}) C_1 + 0 = (1 \text{ L/h}) (10 \text{ mg/L}) + Q (10 \text{ mg/L}) \end{aligned}$$

Solving these two equations gives

$$\begin{aligned} Q^2 + 2 Q - 9,999 &= 0 \\ Q &= 99 \text{ L/h} \end{aligned}$$

The total rinse flow needed for the two tanks is  $2 Q = 198 \text{ L/h}$

In general, the concentrations for crossflow rinsing, with equal flow to each stage, are

$$C_1 = \frac{DC_D}{D+Q} \quad C_2 = \left(\frac{D}{D+Q}\right)^2 C_D \quad \dots \quad C_n = \left(\frac{D}{D+Q}\right)^n C_D$$

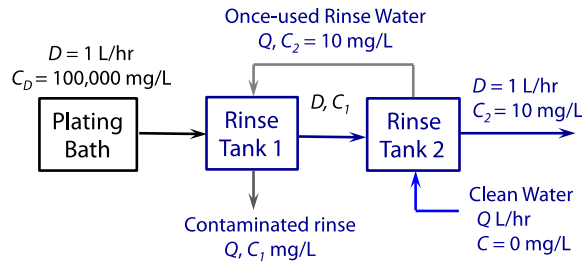
For an  $n$ -stage crossflow rinse for equal flow to each stage is

$$Q_{\text{crossflow}} = D \left[ \left( \frac{C_D}{C_n} \right)^{1/n} - 1 \right]$$

Countercurrent rinsing is better than crossflow rinsing, as Example 4.12 shows.

**Example 4.12 TWO-STAGE COUNTERCURRENT RINSE**

In countercurrent rinsing, Figure 4.21, the dirtiest part is rinsed with once-used water, and cleanest part is rinsed with clean water. The drag-out and rinse water leaving rinse bath 2 have concentration  $C_2 = 10$  mg/L.



**Figure 4.21** Two-stage countercurrent rinsing system

The concentration  $C_1$  is unknown.

The material balance equations are:

$$\begin{aligned} \text{Rinse Bath 1:} \quad & DC_D + QC_2 = DC_1 + QC_1 \\ \text{Rinse Bath 2:} \quad & DC_1 = DC_2 + QC_2 \end{aligned}$$

For  $D = 1$  L/h,  $C_D = 100,000$  mg/L, and  $C_2 = 10$  mg/L

$$\begin{aligned} \text{Rinse Bath 1:} \quad & (1)(100,000) + Q(10) = (1)C_1 + QC_1 \\ \text{Rinse Bath 2:} \quad & (1)C_1 = (1)(10) + Q(10) \end{aligned}$$

Solving these two equations gives

$$\begin{aligned} Q^2 + Q - 9999 &= 0 \\ Q &= 99.5 \text{ L/h} \end{aligned}$$

The equations for a 3-stage countercurrent rinse are

$$\begin{aligned} \text{Stage 1:} \quad & DC_D + QC_2 = DC_1 + QC_1 \\ \text{Stage 2:} \quad & DC_1 + QC_3 = DC_2 + QC_2 \\ \text{Stage 3:} \quad & DC_2 + 0 = DC_3 + QC_3 \end{aligned}$$

The approximate equations are

$$\begin{aligned} \text{Stage 1:} \quad & DC_D + QC_2 = QC_1 \\ \text{Stage 2:} \quad & DC_1 + QC_3 = QC_2 \quad C_1 = (Q/D)^2 C_3 - (Q/D)C_3 \\ \text{Stage 3:} \quad & DC_2 = QC_3 \quad C_2 = QC_3/D \end{aligned}$$

Substituting these results into the material balance equation for Stage 1 gives

$$Q = D \left( \frac{C_D}{C_3} \right)^{1/3}$$

In general, for a  $n$ -stage counter current rinse

$$Q = D \left( \frac{C_D}{C_n} \right)^{1/n}$$

Table 4.1 summarizes the results for  $D = 1$  L/h and  $C_D = 100,000$  mg/L. The single-stage rinse will use the most water. The 2-stage crossflow rinse without recycle is better, but rinsing with countercurrent recycle is the most efficient system we can devise. Some results for 3-stage rinse systems are included in Table 4.1.

Rinse Design	Total flow (L/h)	Concentration of rinse water			
		Tank 1	Tank 2	Tank 3	Composite
Single-stage	9,999	10			10
Two-stage Crossflow	198 (99 per stage)	1,000	10		505
Two-stage Countercurrent	99.5	1,005			1,005
Three-stage Crossflow	61.5 (20.5 per stage)	4,642	215	10	1,622
Three-stage Countercurrent	21	4,716			4,716

**Table 4.1** Summary of results (exact solution) for rinsing when  $D = 1$  L/h and  $C_0 = 100,000$  mg/L

Adding more stages reduces the amount of rinse water and increases the concentration of the contaminated rinse water. Two and three-stage systems are widely used. The cost of space, tanks, and plumbing discourages using more tanks.

Countercurrent processing is used in many different processes, including soil washing, carbon adsorption, and air stripping.

I joined MITAS because  
I wanted **real responsibility**

The Graduate Programme  
for Engineers and Geoscientists  
[www.discovermitas.com](http://www.discovermitas.com)



Real work  
International opportunities  
Three work placements



**Month 16**  
I was a construction  
supervisor in  
the North Sea  
advising and  
helping foremen  
solve problems





## 4.9 Application – Effluent Limits and Waste Load Allocation

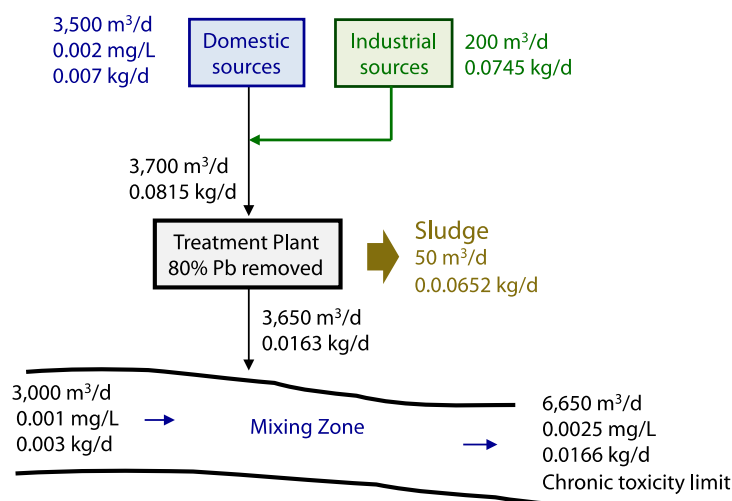
Every municipality has pretreatment regulations and sewer ordinances that set limits on substances that might expose the sewer system to corrosion, clogging, explosion, and other risks. Pretreatment regulations prohibit industry from discharging any toxics or other substance (priority pollutants) that will:

- pass through the municipal treatment works and violate the discharge permit
- interfere with sludge disposal, or
- interfere with the treatment process.

Domestic and industrial wastewater, in the respective flows of 3,500 m<sup>3</sup>/d and 200 m<sup>3</sup>/d, are treated jointly in a municipal treatment plant and discharged to a river. The sludge removed from the treatment plant is 50 m<sup>3</sup>/d, leaving an effluent of 3,650 m<sup>3</sup>/d that is discharged to the river. The treatment plant removes 80% of the influent lead and this leaves the plant in the sludge.

The concentration of lead in the domestic wastewater is 0.002 mg/L and the concentration in the river upstream from the discharge is 0.001 mg/L. The aquatic chronic toxicity limit of 2.5 µg/L (0.0025 mg/L) must be satisfied at the critical flow condition, which is when the treatment plant effluent is 3,650 m<sup>3</sup>/d and the stream flow is 3,000 m<sup>3</sup>/d. Toxicity and water quality limits are explained in Berthouex & Brown (2013).

Figure 4.22 shows the completed material balances on lead and flow, and the waste load allocation.



**Figure 4.22** Domestic and industrial wastewater are treated jointly in the publicly owned treatment works and discharged to a river. The wasteload allocation satisfies the requirements for river quality, sludge quality and treatment process protection, and it includes an allowance for future growth.

Mass flow of Pb measured in the river upstream of the mixing zone

$$Pb_{up} = (3,000 \text{ m}^3/\text{d})(0.001 \text{ mg/L}) (0.001) = 0.003 \text{ kg/d}$$

Mass of Pb allowed for a combined river and effluent flow of 6,650 m<sup>3</sup>/d at 0.0025 mg/L is

$$Pb_{down} = (6,650 \text{ m}^3/\text{d})(0.0025 \text{ mg/L})(0.001) = 0.0166 \text{ kg/d}$$

Mass of Pb allowed in the POTW effluent

$$Pb_{eff} = (Pb_{down} - Pb_{up}) = 0.0166 - 0.003 = 0.0163 \text{ kg/d}$$

Mass of Pb allowed in the treatment plant influent, assuming 80% removal of the influent Pb,

$$Pb_{eff} = (1 - 0.80)Pb_{inf}$$

$$Pb_{inf} = 0.0163/0.20 = 0.0815 \text{ kg/d}$$

Mass Pb contributed in domestic wastewater

$$Pb_{dom} = (3,500 \text{ m}^3/\text{d})(0.002 \text{ mg/l})(0.001) = 0.007 \text{ kg/d}$$

Mass Pb load from industrial wastewater

$$Pb_{ind} = Pb_{inf} - Pb_{dom} = 0.0815 - 0.007 = 0.0745 \text{ kg/d}$$

The mass loadings can be converted to concentrations:

$$\text{Treatment plant influent} = (0.0815 \text{ kg/d})(1000)/(3,700 \text{ m}^3/\text{d}) = 0.022 \text{ mg/L}$$

$$\text{Industrial wastewater} = (0.0745 \text{ kg/d})(1000)/(200 \text{ m}^3/\text{d}) = 0.372 \text{ mg/L Pb}$$

$$\text{Treatment plant effluent} = (0.0163 \text{ kg/d})(1000)/3,685 \text{ m}^3/\text{d}) = 0.0044 \text{ mg/L}$$

The treatment plant can reserve 20–50% of the wasteload allocation for future growth. The industrial contribution would be reduced by the reserved amount, and the treatment plant influent and effluent concentrations will be reduced, as will the downstream concentration in the river. The reader may wish to make these calculations as an exercise.

The lead concentration used in these calculations was *total lead*, or *total recoverable metal* in the language of the laboratory test methods. Some fraction of the total lead is not available in a toxic form to the protected organisms. The free-ion form (non-complexed form) is generally thought to be the most bioavailable and toxic. This form is difficult to measure and for practical reasons it seldom is. Expressing effluent and ambient toxicity limits as total recoverable metal provides for the maximum toxic potential should all the metal somehow revert to its most toxic form when mixed with the receiving water.



There can be a discrepancy between the toxic effects observed in laboratory tests and in a specific river. These differences are attributed to difference in the physical and chemical forms of the metals in the two environments. The water-effects ratio (WER) procedure is an accepted procedure to make site-specific adjustments for the reduced metals bioavailability (Berthouex & Brown 2013). The WER is the ratio of the toxic endpoint in river water at the discharge point to the toxic endpoint in laboratory water. This is a direct measure of the amount by which the permit limit could be raised without increasing risk to aquatic organisms.

#### 4.10 Material Balance for Partitioning Between Air, Water, and Soil

A chemical that enters the environment may become associated with the soil, water, air, or biota as shown in Figure 4.23. Predicting where the chemical goes is a special kind of material balance that estimates how much of the chemical will be found in each environmental compartment.

We will consider the special situation where the chemical concentrations in the water, soil, biota, and air are in equilibrium with each other. Equilibrium means that the concentrations are not changing over time. It may seem unrealistic to think of equilibrium in a lake or pond, where conditions are changing constantly, but there is a lot of averaging and blending happening and it can be a reasonable approximation. Also, for practical purposes, we can assume that equilibrium between air and water is reached quickly (seconds or minutes), and equilibrium between water and solids is reached within hours or a few days. Reaching equilibrium between water and biota takes longer.

**ie** business school

#1 EUROPEAN BUSINESS SCHOOL  
FINANCIAL TIMES 2013

#gobeyond

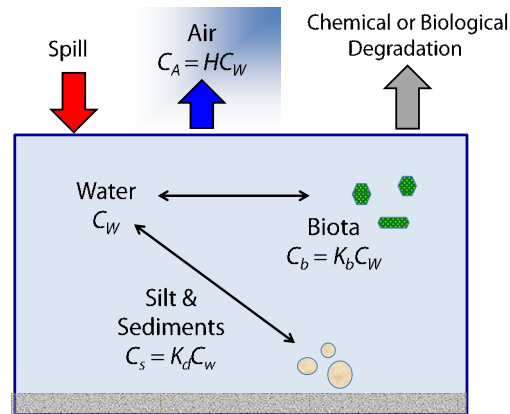
**MASTER IN MANAGEMENT**

**Because achieving your dreams is your greatest challenge.** IE Business School's Master in Management taught in English, Spanish or bilingually, trains young high performance professionals at the beginning of their career through an innovative and stimulating program that will help them reach their full potential.

- Choose your area of specialization.
- Customize your master through the different options offered.
- Global Immersion Weeks in locations such as London, Silicon Valley or Shanghai.

*Because you change, we change with you.*

www.ie.edu/master-management | mim.admissions@ie.edu | f t in YouTube



**Figure 4.23** The scheme for modeling the fate of a chemical in an environmental compartment

The equilibrium concentrations in two compartments, such as soil and water, are related by simple proportionality factors. The proportionality factors, which are called *partition coefficients*, indicate how a chemical will be partitioned (i.e. distributed) between the two compartments.

The most familiar of these proportional relations is *Henry's Law*, which defines the relation between concentrations in water and air at equilibrium. At a given temperature,

$$C_a = H C_w$$

where  $H$  = Henry's Law Constant  
 $C_a$  = air phase concentration  
 $C_w$  = water phase concentration.

$H$  is the partition coefficient for the gas-water system. In environmental work, the gas of interest is often air, but Henry's law also applies to other gases. A large value of  $H$  indicates that the chemical will tend to move easily from water to air.

The units of  $H$  depend on the units used to define the concentrations.  $H$  is dimensionless if both phases are defined in the same units of mass per unit volume, for example mg/L,  $\mu\text{g/L}$ , or  $\text{mg/m}^3$ . If  $C_a$  is defined with units of partial pressure in atmospheres and  $C_w$  is measured in mg/L, the units of  $H$  are atm-L/mg. Many combinations of units have been used and one must check carefully to avoid mistakes. We will use the dimensionless form.

Similar partition coefficients can be defined for other two-phase equilibrium systems. For a soil-water system

$$C_s = K_d C_w$$

where  $C_s$  = concentration in the soil phase  
 $C_w$  = concentration in water.

$K_d$  increases as the organic content of the soil increases because an organic chemical tends to associate more strongly with other organic matter than with inorganic matter like silica and calcium carbonate. This simple form is valid when the pollutant concentration is low. At high concentrations the surface of the solid becomes saturated with chemical and the linear proportion is not valid.

The *partition coefficient* between water and biota,  $K_b$ , is called the *bioconcentration factor*

$$C_b = K_b C_w$$

where  $C_b$  (mg/kg) is the concentration of chemical in the biota (e.g. fish).

The time needed for a fish to come into equilibrium with a chemical in water depends on the relative rate at which the fish takes up the chemical and the rate at which it can cleanse itself of the chemical by excretion, metabolism, or other means. The collective effect of all the active cleansing mechanisms is called *depuration*. Equilibrium exists when the rates of uptake and depuration are equal.

A fish may continue to take up chemical as it grows and, as a result, strict equilibrium may not be reached. This is why advisories on eating fish with contaminated flesh are based on the size of the fish. Larger fish tend to have higher contaminant concentrations. The practical solution to this complication is to assume that the bioconcentration factor represents an average over fish of all species and all sizes.

**Example 4.13 ESTIMATING THE BIOCONCENTRATION FACTOR**

The bioconcentration factor is the equilibrium ratio of the chemical concentration in the fish flesh to the concentration in the water. The data in Figure 4.24 were obtained by keeping fish in water having a constant level of 10 µg/L of Chemical A for 40 days and then putting the fish into clean water. Fish were sacrificed every few days to measure the chemical content of their flesh.

After 40 days, the concentration in the fish is still changing, but only a little, so the bioassay system is essentially at equilibrium. The equilibrium fish flesh concentration is  $C_b = 4000 \mu\text{g/kg}$ . The water concentration was maintained at a constant  $C_w = 10 \mu\text{g/L}$ .

The bioconcentration factor is

$$K_b = C_b/C_w = 4000/10 = 400 (\mu\text{g/kg})/(\mu\text{g/L})$$

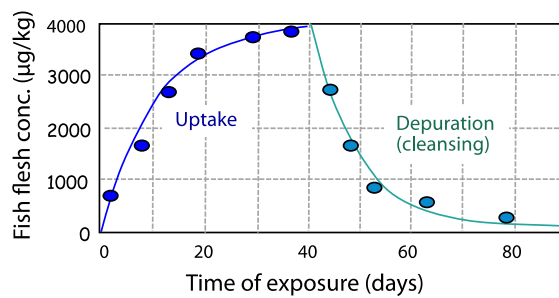


Figure 4.24 Fish uptake and depuration of Chemical A



**no.1**  
nine years  
in a row

## STUDY AT A TOP RANKED INTERNATIONAL BUSINESS SCHOOL

Reach your full potential at the Stockholm School of Economics, in one of the most innovative cities in the world. The School is ranked by the Financial Times as the number one business school in the Nordic and Baltic countries.

Visit us at [www.hhs.se](http://www.hhs.se)






To summarize, partitioning between air, water, soil, and biota is defined by:

$$\text{Air-Water: } C_a = C_w H \text{ (Henry's Law)}$$

$$\text{Soil-Water: } C_s = C_w K_d$$

$$\text{Biota-water: } C_b = C_w K_b$$

where  $C_a$  = concentration in air (mass/volume)  
 $C_w$  = concentration in water (mass/volume)  
 $C_s$  = concentration in solid (mass/mass)  
 $C_b$  = concentration in biota (mass/mass)  
 $H$  = Henry's Law Constant (dimensionless)  
 $K_d$  = Soil-water partition coefficient (volume/mass).  
 $K_b$  = Bioconcentration factor (volume/mass)

Another important proportionality factor is the *octanol-water partition coefficient*,  $K_{ow}$ . This coefficient is measured by introducing the chemical into a mixture of water and octanol, an organic solvent, shaking the mixture until equilibrium is attained, and then measuring the concentration of chemical in the solvent and in the water. Chemists have measured  $K_{ow}$  for many compounds and have determined a relationship between  $K_{ow}$  and the soil-water partition coefficient  $K_d$ , and between  $K_{ow}$  and the bioconcentration factor,  $K_b$ .

#### 4.11 Application: Partitioning to Pyrene in a Small Lake

An accident has spilled 400 kg of pyrene into a small lake. After some time, the water concentration  $C_w = 0.01$  mg/L. Assume the system is at equilibrium and that the water flowing into and out of the lake is negligible. Estimate the mass of chemical in the water, soil, and biota. Also estimate the mass of chemical lost from the system.

The partition coefficients are

$$\text{Soil-Water } K_d = 84 \frac{\text{mg/kg soil}}{\text{mg/L water}}$$

$$\text{Biota-Water } K_b = 700 \frac{\text{mg/kg biota}}{\text{mg/L water}}$$

The equilibrium concentrations of pyrene for each compartment are:

$$\text{Water } C_w = 0.01 \text{ mg/L}$$

$$\text{Soil } C_s = K_d C_w = \left( 84 \frac{\text{mg/kg soil}}{\text{mg/L water}} \right) (0.01 \text{ mg/L water}) = 0.84 \frac{\text{mg Pyrene}}{\text{kg soil}}$$

$$\text{Biota } C_b = K_b C_w = \left( 700 \frac{\text{mg/kg biota}}{\text{mg/L water}} \right) (0.01 \text{ mg/L water}) = 7.0 \frac{\text{mg Pyrene}}{\text{kg biota}}$$



The material balance assumes that the lake can be approximated as three homogeneous compartments (water, soil/sediment, and biota). The system has a total area of 1 km<sup>2</sup>. The lake volume is 10,000,000 m<sup>3</sup> of water. There is 100,000 m<sup>3</sup> of affected soil that has a density of 1,300 kg/m<sup>3</sup>. The lake contains 60,000 kg biota that has a density of 1,000 kg/m<sup>3</sup>.

The material balance is:

$$\left[ \begin{array}{c} \text{Mass of} \\ \text{Pyrene spilled} \end{array} \right] - \left[ \begin{array}{c} \text{Loses of} \\ \text{Pyrene} \end{array} \right] = \left[ \begin{array}{c} \text{Mass Pyrene} \\ \text{in water} \end{array} \right] + \left[ \begin{array}{c} \text{Mass Pyrene} \\ \text{in soil} \end{array} \right] + \left[ \begin{array}{c} \text{Mass Pyrene} \\ \text{in biota} \end{array} \right]$$

Masses of pyrene in each compartment:

$$\begin{aligned} M_w &= (10^7 \text{ m}^3) \left( 1000 \frac{\text{L}}{\text{m}^3} \right) \left( 10^{-6} \frac{\text{kg}}{\text{mg}} \right) C_w \\ &= \left( 10^4 \frac{\text{kg-L}}{\text{mg}} \right) \left( 0.01 \frac{\text{mg}}{\text{L}} \right) = 100 \text{ kg Pyrene} \end{aligned}$$

$$\begin{aligned} M_s &= (10^5 \text{ m}^3 \text{ soil}) \left( 84 \frac{\text{mg/kg soil}}{\text{mg/L water}} \right) \left( 1,300 \frac{\text{kg soil}}{\text{m}^3 \text{ soil}} \right) \left( 10^{-6} \frac{\text{kg}}{\text{mg}} \right) C_w \\ &= \left( 10,920 \frac{\text{kg-L}}{\text{mg}} \right) \left( 0.01 \frac{\text{mg}}{\text{L}} \right) = 109.2 \text{ kg Pyrene} \end{aligned}$$

**#1**  
in eco-friendly attitude

**STUDY AT  
LINKÖPING UNIVERSITY, SWEDEN**  
RANKED AMONG TOP 50 UNIVERSITIES UNDER 50

Interested in Strategy and Management in International Organisations? Kick-start your career with a master's degree from Linköping University, Sweden.

→ **Click here!**

 **Linköping University**

$$M_B = \left( 700 \frac{\text{mg/kg biota}}{\text{mg/L water}} \right) (60,000 \text{ kg biota}) \left( 10^{-6} \frac{\text{kg}}{\text{mg}} \right) C_w = \left( 42 \frac{\text{kg-L}}{\text{mg}} \right) \left( 0.01 \frac{\text{mg}}{\text{L}} \right) = 0.42 \text{ kg Pyrene}$$

$$M_{\text{Lost}} = 400 \text{ kg} - 100 \text{ kg} - 109.2 \text{ kg} - 0.42 \text{ kg} = 190.38 \text{ kg}$$

Rounding these results to a useful approximation, the fate of the 400 kg of chemical spilled is:

- 47% of the total spilled has disappeared from the water
- 25% is in the water
- 27% is in the soil and sediment
- Less than 1% is in the biota.

The mechanisms that might cause the chemical to disappear are microbial degradation, volatilization to the air, and hydrolysis.

## 4.12 Conclusion

All the examples in this chapter are for *steady state* processes. Steady state is an ideal, but it is a useful and workable ideal during design.

The material balance is the most valuable tool for analyzing pollution problems. We use it to expand fragmentary information into a more complete picture that suggests creative solutions for controlling pollutant emissions. It facilitates discovery of opportunities to minimize the creation of wastes and to recover and recycle material. Recognizing that zero emissions is almost never possible, the material balance also guides the designer in formulating treatment systems to deal with pollutant discharges that cannot be avoided.

Real processes are never stationary. Conditions change rapidly when a process is being started or shut down. Conditions drift and change slowly during normal operation. Ambient conditions and raw materials change, mechanical parts wear out, and so on. This is why there are sometimes problems with output quality and process stability. Maintaining tight control of a real operating system may require dealing with these dynamic and drifting conditions.

Inputs to most pollution control systems can be highly variable. The flow into a municipal wastewater treatment plant may change by a factor of three or four in a 24-hour period. The average flow on the peak day may be triple the average flow. Concentrations and mass loadings will change in similar ratios.

A treatment plant typically is designed for a 20-year service life, and the flows and loads will grow from the beginning to the end of the design period.



The designer deals with this by assuming and analyzing steady-state conditions at the estimated 'average day design flow' and 'peak design flow' at the end of the design period. Cold winter weather will slow down a biological process, and warm summer weather will decrease the efficiency of supplying oxygen to aerobic treatment processes, so these critical conditions are checked.

In other words, the designer imagines that the system must function for an extended period of time, at a stable, steady state, under the most critical high and low flow loads and environmental conditions. A design that can survive these extremes is expected to also survive all the daily and seasonal dynamics.



"I studied English for 16 years but...  
...I finally learned to speak it in just six lessons"  
Jane, Chinese architect

ENGLISH OUT THERE

Click to hear me talking before and after my unique course download



# 5 Solving Systems of Equations

## 5.1 The Design Problem

A processing system consists of easily identifiable components or modules, such as mixers, reactors, settling tanks, filters, heat exchangers, and so on. These component parts are arranged to interact with each other to perform some larger function. A single component may be fully constrained by its connections to other parts of the system, but the organized components will offer the designer some flexibility to select the best flow rates, operating temperatures, pH, detention times, and other details.

The designer will use a collection of design equations, including material and energy balances, along with additional information in the form of performance tables and graphs, and cost estimating manuals. When this information is organized and reduced to something definite and manageable there will be certain variables that the designer is free to adjust to search for the design that best meets the processing need.

To make use of this flexibility and freedom it helps to understand and organize the information flow structure of the design equations because this can lead to significant simplifications in the calculations.

## 5.2 Design Degrees of Freedom

There will be, in general,  $N$  sources of information about the system, including references to  $M$  variables (equipment size, flow rates, etc.). The design relations must be independent sources of information, and any relation that can be derived from the others should be eliminated in the tally of equations.

In general, the number of degrees of freedom is the difference between the number of pertinent variables ( $M$ ) and the number of independent design relations ( $N$ ).

$$F = M - N$$

This means that  $F$  of the system variables may be selected as *design variables*, the values of which are *free* to be adjusted. The remaining variables are called *state variables*. Once the designer has assigned values to the *design variables*, the *state variables* are obtained by solving the set of design relations.

The number of degrees of freedom will not be obvious in a large problem. Murphy (2007) is an excellent resource, with several examples, for those who wish to learn more about this. Other good references are Himmelblau & Riggs (2004) and Rudd & Watson (1968).

The most interesting case is when  $N \leq M$  so the design can be manipulated in order to find the best conditions. The number of variables the designer controls,  $F = (M - N) > 0$ , is the design *degrees of freedom*. The designer assigns values for these variables, called *design variables*, in order to create a solvable system of  $N$  equations and  $N$  unknowns. Different values can be assigned to create new designs. In this way the design improves iteration by iteration. Chapter 14 (section 14.6) gives an example with one degree of freedom.

A second case is when the number of equations equals the number of unknowns. That is,  $N = M$  and  $F = M - N = 0$ . There are no degrees of freedom. The designer has no flexibility to optimize the design because there is only one solution.

A third possibility is poorly formulated problem that has  $N > M$ , in which case it is generally not possible to find values for all of the  $M$  variables that satisfy the design relations.

Excellent Economics and Business programmes at:



university of  
 groningen



“The perfect start  
of a successful,  
international career.”

**CLICK HERE**  
to discover why both socially  
and academically the University  
of Groningen is one of the best  
places for a student to be

[www.rug.nl/feb/education](http://www.rug.nl/feb/education)



**Example 5.1** BLENDING PROBLEM – CONTRADICTORY PROBLEM FORMULATION

Figure 5.1 shows a blender designed to mix materials A and B to produce 2,000 kg of material C. The buyer specifies that  $R = B/A = 4$ . There are  $N = 5$  design relations and  $M = 4$  variables. It not possible to solve for B because  $N > M$  is an impossible contradiction.



Figure 5.1 Blending:  $A + B = C$

Material Balance:	$A + B = C$
Quality of the blend:	$R = B/A$
Specifications:	$A = 1,000 \text{ kg}$
	$C = 2,000 \text{ kg}$
	$R = 4$

**Example 5.2** BLENDING PROBLEM – FULLY CONSTRAINED FORMULATION

Relaxing the specification on the amount of C produced by the blender gives these design equations

Material Balance:	$A + B = C$
Quality of the blend:	$R = B/A$
Specifications:	$A = 1,000 \text{ kg}$
	$R = 4$

There are  $N = 4$  design relations and  $M = 4$  variables (A, B, C and R).

The solution is

$$B = RA = 4(1,000) = 4,000 \text{ kg}$$

$$C = A + B = 1,000 + 4,000 = 5,000 \text{ kg}$$

**Example 5.3** BLENDING PROBLEM – FLEXIBLE DESIGN

The specification on the amount of C and the value of K can be relaxed to give one degree of freedom.

Material Balance:	$A + B = C$
Quality of blend:	$R = B/A$
Specifications:	$A = 1,000 \text{ kg}$

Then  $N = 3$ ,  $M = 4$ , and  $F = 4 - 3 = 1$  degree of freedom to explore different designs.

A value can be assigned for B to calculate K, or vice versa. Blends with different values of K will have different properties and hence different market values. The designer’s freedom might be used to explore a goal such as “Maximize the cost of the blend, C, minus the cost of the raw materials, A and B.”

### 5.3 Design Variable Selection

Given a design problem with  $F = M - N$  degrees of freedom, the designer must select F variables to consume those degrees of freedom and create a solvable problem with N design relations that will be used to calculate the N state variables.

Three rules-of-thumb are:

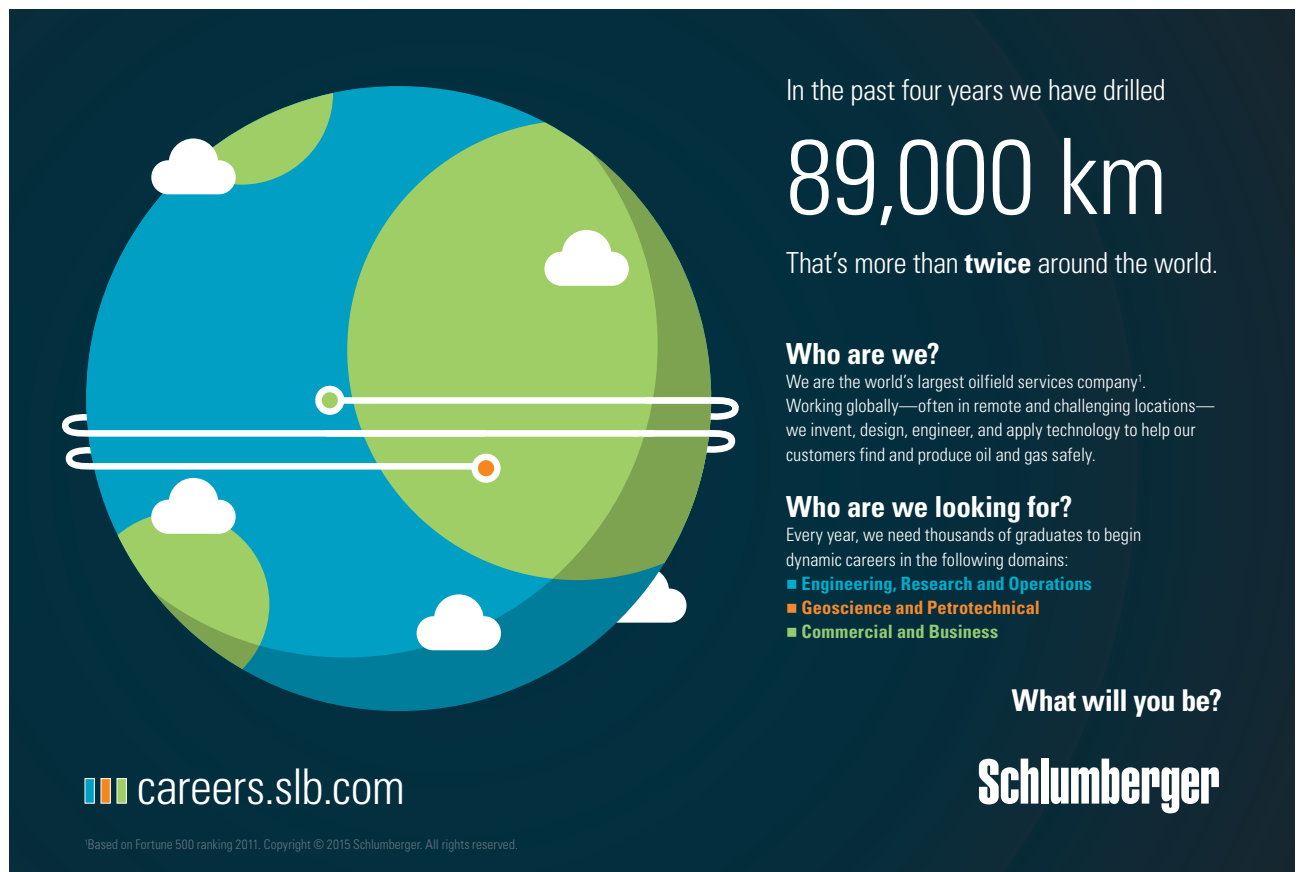
- 1) When a variable involves a choice among discrete alternatives it is usually best to make the discrete variable a design variable. This is shown in Example 5.4.
- 2) The design variables should, when possible, be those variables that are most constrained.
- 3) If the design equations include exponential, logarithmic, or trigonometric functions, the solution will be easier if the variable in the argument (e.g. the  $t$  in  $x = \exp(-t)$  or  $\theta$  in  $x = 2 + \cos\theta$ ) can be made a design variable.

For this equation

$$A = 20[\exp(-0.2t) - \exp(-0.5t)]$$

either  $A$  or  $t$  could be the design variable. The better choice is  $t$  because this allows a direct solution for  $A$ . Specifying  $A$  would require a more difficult calculation. This is an example of how the design variable selection can influence the work required to solve the equations.

Design variable selection can be important even for a set of simple equations. Example 5.5 shows how the selection can simplify the calculations by avoiding simultaneous equations.



In the past four years we have drilled

# 89,000 km


That's more than **twice** around the world.


**Who are we?**  
We are the world's largest oilfield services company<sup>1</sup>. Working globally—often in remote and challenging locations—we invent, design, engineer, and apply technology to help our customers find and produce oil and gas safely.

**Who are we looking for?**  
Every year, we need thousands of graduates to begin dynamic careers in the following domains:

- Engineering, Research and Operations
- Geoscience and Petrotechnical
- Commercial and Business

**What will you be?**

 careers.slb.com

 Schlumberger

<sup>1</sup>Based on Fortune 500 ranking 2011. Copyright © 2015 Schlumberger. All rights reserved.

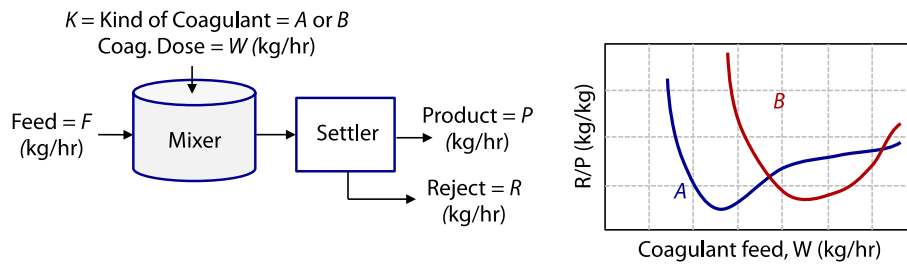


**Example 5.4 MAXIMIZING PRODUCT RECOVERY**

Coagulant A or B is to be mixed with the feed to facilitate concentration of the product,  $P$ , and minimize the reject,  $R$ . The relation between the kind of coagulant,  $K$ , the coagulant dose,  $W$ , and the reject/product ratio ( $R/P$ ) is known from experiments and is expressed as a graph.  $K$  is a discrete variable;  $K = \text{kind A}$  or  $K = \text{kind B}$ . The mixer-settler and the performance graph are Figure 5.2. The goal is to maximize the profit by selecting the best coagulant (A or B) and coagulant dosage.

$$\text{Maximize Profit} = \left[ \text{Cost of product} \right] - \left[ \text{Cost of feedstock} \right] - \left[ \text{Cost of coagulant} \right]$$

( $W, K = A \text{ or } B$ )



**Figure 5.2** Mixer-settler process with coagulant addition

The  $N = 3$  design relations are:

$$F = 1000 \text{ kg}$$

$$F = R + P$$

$$R/P = f(W, K)$$

The  $M = 5$  variables are  $F, R, P, W$  and coagulant type ( $K = A$  or  $K = B$ )  
*Degrees of freedom:*  $F = 5 - 3 = 2$

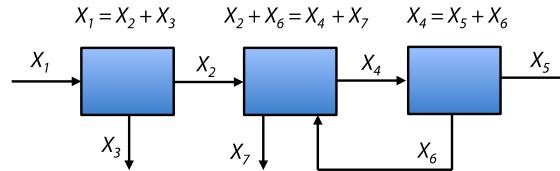
The feasible choices of the 2 design variables are:

- |    |             |  |
|----|-------------|--|
| 1) | $W$ and $K$ | Determine $R/P \rightarrow R$ and $P$  |
| 2) | $P$ and $W$ | Determine $R$ and $K$ (coagulant type) |
| 3) | $R$ and $W$ | Determine $P$ and $K$ (coagulant type) |

Choice 1 is an easy calculation. Choices 2 and 3 are several times more difficult.

**Example 5.5 DESIGN VARIABLE SELECTION TO SIMPLIFY CALCULATIONS**

Figure 5.3 shows a simple system with  $M = 7$  variables,  $N = 3$  material balance equations, and  $F = 7 - 3 = 4$  degrees of freedom. Assume that  $X_1$  and  $X_5$  are specified by external conditions, say  $X_1 = 100$  and  $X_5 = 2$ . This reduces the degrees of freedom from 4 to 2. It does matter which two variables are selected as design variables.

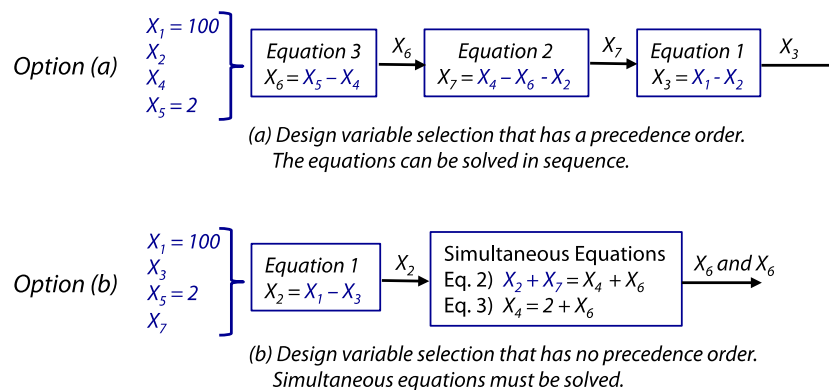


**Figure 5.3** Hypothetical system with  $M = 7$ ,  $N = 3$  and  $F = 7 - 3 = 4$ .

Figure 5.4 shows two possible selections of design variables. The given input values are  $X_1 = 100$  and  $X_5 = 2$  in both cases.

In Option (a),  $X_2$  and  $X_4$  are the design variables; they will be specified by the designer. This selection allows the three equations to be solved one after another, with each equation yielding a value for one more variable. The sequence of solution is known as the *precedence order*.

Option (b) selects  $X_3$  and  $X_7$  as design variables. This selection has no precedence order and solving simultaneous equations is necessary.



**Figure 5.4** Two possible selections of design variables for the system in Figure 5.3. The design variable selection in Option (a) allows the equations to be solved sequentially. The selection in Option (b) makes this impossible.

## 5.4 Information Flow and Precedence Order

Figure 5.5 shows a simple system in which 70% of the feed is captured in process 1 and directed into process 2, where 95% of the feed is captured as product and 5% is lost as waste. There are 5 equations and 5 variables. A sixth equation, the overall material balance, could be written but it is redundant.



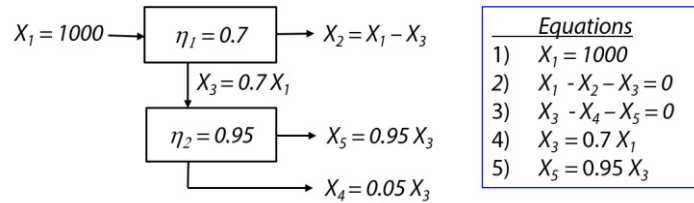


Figure 5.5 Mass flow through a simple system.

Figure 5.6 shows the structure of the material balance equations.

- 1)  $X_1 = 1000$  (Basis)
- 2)  $X_1 - X_2 - X_3 = 0$
- 3)  $X_3 - X_4 - X_5 = 0$
- 4)  $X_3 = 0.7 X_1$
- 5)  $X_5 = 0.95 X_3$

## American online

# LIGS University

is currently enrolling in the  
Interactive Online **BBA, MBA, MSc,**  
**DBA and PhD** programs:

- ▶ enroll **by September 30th, 2014** and
- ▶ **save up to 16%** on the tuition!
- ▶ pay in 10 installments / 2 years
- ▶ Interactive **Online** education
- ▶ visit [www.ligsuniversity.com](http://www.ligsuniversity.com) to find out more!

Note: LIGS University is not accredited by any nationally recognized accrediting agency listed by the US Secretary of Education. More info [here](http://www.ligsuniversity.com).





Click on the ad to read more

This system has  $N = 5$  equations with  $M = 5$  variables. Specifying the basis,  $X_1 = 1000$ , consumes one degree of freedom, leaving  $N = M = 4$  and  $X_2, X_3, X_4$  and  $X_5$  as unknowns. There is a unique solution and the equations can be solved sequentially, for example, in this order

$$\begin{array}{ll} \text{Eq. 4} & X_3 = 0.7 X_1 & X_3 = 0.7(1000) = 700 \\ \text{Eq. 5} & X_5 = 0.95 X_3 & X_5 = 0.95(700) = 665 \\ \text{Eq. 3} & X_4 = X_3 - X_5 & X_4 = 700 - 665 = 35 \\ \text{Eq. 2} & X_2 = X_1 - X_3 & X_2 = 1000 - 700 = 300 \end{array}$$

If the equations can be solved sequentially without dealing with simultaneous equations, the sequence in which the equations are to be solved is called the *precedence order*. This precedence order (solving equation 4, 5 3 and 2, in that order) is not unique for these equations. The important characteristic is that there is a sequence that allows the needed information to flow from one equation to the next so they can be solved one by one.

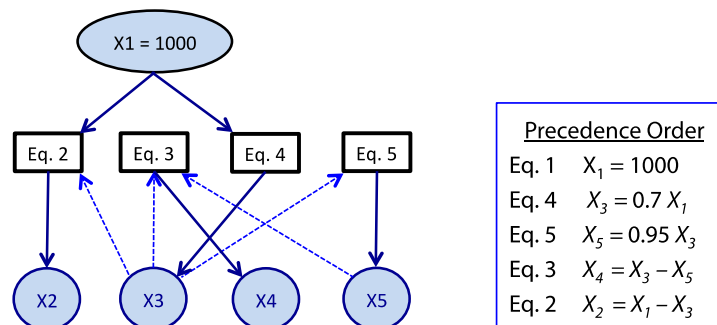


Figure 5.6 The information flow diagram and precedence order for the system shown in Figure 5.5.

Figure 5.6 shows the flow of information from one equation to another. The arrows with solid lines represent a calculated value (an  $X$ ). Arrows with dotted lines represent the known value of a variable entering an equation.

The fixed value,  $X_1 = 1000$ , is used first in Equation 4 and later in Eq. 2. Equation 4 yields a value for  $X_3$ , which is used in Eq. 5 to calculate  $X_5$  and in Eq. 2 to calculate  $X_2$ . Eq. 3 can then be solved using the calculated values of  $X_5$  and  $X_3$ .

## 5.5 Iterative Solutions of Systems with Information Recycle

*Information recycle* in a system of equations means two variables are linked and cannot be separated from each other. This can occur in models for processes that do not have physical recycle of material.

Here is an example of two nonlinear equations that both contain  $x_1$  and  $x_2$ .

$$\begin{array}{l} x_1 = 10 \exp(-0.1x_2) \\ x_2 = 10[1 - \exp(-0.2x_1)] \end{array}$$

Sequential computation is not possible. There is no practical solution except iteration. Figure 5.7 shows four possible iterative schemes. The *tear variable* – the variable you choose to specify (i.e. to guess) in order to start the calculations – can be either  $x_1$  or  $x_2$  and for each choice there are two directions for the information to flow. The four schemes are not equal in terms of computational work.

If  $x_1$  is the tear variable, it is much easier to calculate  $x_2$  using the information flow shown in Figure 5.8(b). That is,  $x_2$  is calculated directly if  $x_1$  is entered into

$$x_2 = 10[1 - \exp(-0.2x_1)]$$

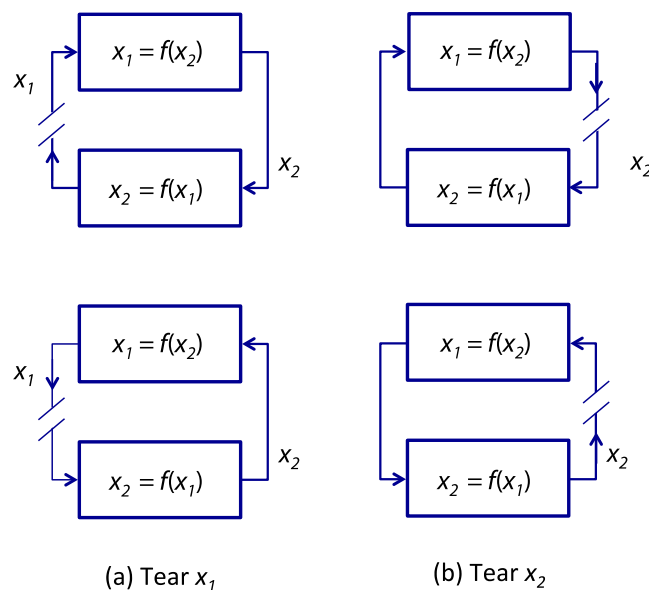
but this is not true when using

$$x_1 = 10 \exp(-0.1x_2).$$

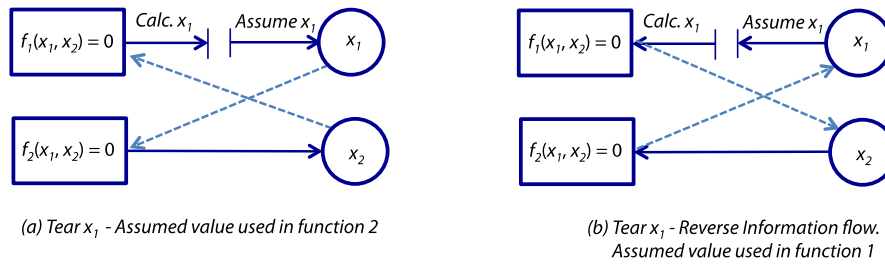
If, on the other hand,  $x_2$  is selected as the tear variable, the most direct information flow is from  $x_1$  to  $x_2$ , as used in iterative solution in Table 5.1. Both functions give values of  $x_1$  and  $x_2$  between 0 and 10. Assume a mid-range initial value, say  $x_2 = 5$

Iteration 1	$x_2 = 5$	$x_1 = 10 \exp[-0.1(5)] = 5.488$	→	$x_2 = 10 [1 - \exp[-0.2](5.488)] = 6.663$
Iteration 2	$x_2 = 6.633$	$x_1 = 10 \exp[-0.1(6.633)] = 5.136$	→	$x_2 = 10 [1 - \exp[-0.2](5.136)] = 6.420$
Iteration 3	$x_2 = 6.420$	$x_1 = 10 \exp[-0.1(6.420)] = 5.262$	→	$x_2 = 10 [1 - \exp[-0.2](5.262)] = 6.509$
Iteration 4	$x_2 = 6.509$	$x_1 = 10 \exp[-0.1(6.509)] = 5.216$	→	$x_2 = 10 [1 - \exp[-0.2](5.216)] = 6.476$
Iteration 5	$x_2 = 6.476$	$x_1 = 10 \exp[-0.1(6.476)] = 5.233$	→	$x_2 = 10 [1 - \exp[-0.2](5.233)] = 6.488$
Iteration 6	$x_2 = 6.484$	$x_1 = 10 \exp[-0.1(6.484)] = 5.226$	→	$x_2 = 10 [1 - \exp[-0.2](5.226)] = 6.484$

**Table 5.1** Iterative solution of two equations



**Figure 5.7** Two possibilities for tearing and four possible arrangements of the information flow.



**Figure 5.8** The two equations displayed as a graph to show two directions of information flow after tearing  $x_1$ . The boxes are the equations and the circles are the variables.

## 5.6 Systems with Physical Recycle of Material

There are systems of equations where information flows between equations in recycle loops that cannot be unraveled regardless of the design variable selection. The solution then requires solving simultaneous equations or doing an iterative solution. Solving simultaneous equations is feasible for a simple problem, but it is not when the equations are quadratic, cubic, or when the equations contain exponential, logarithmic, or trigonometric functions. In that case an iterative solution will be used. Many software design packages use this method without the user being aware of what is happening.

.....Alcatel-Lucent 

[www.alcatel-lucent.com/careers](http://www.alcatel-lucent.com/careers)

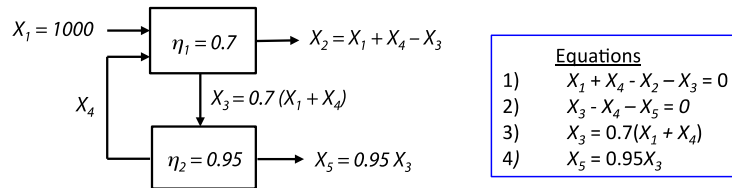
What if you could build your future and create the future?

One generation's transformation is the next's status quo. In the near future, people may soon think it's strange that devices ever had to be "plugged in." To obtain that status, there needs to be "The Shift".

 Click on the ad to read more

**Example 5.6 MATERIAL BALANCE FOR TWO PROCESSES WITH RECYCLE**

The process in Figure 5.9 shows the mass flow of material through two processes with recycle. The material balance equations are



**Figure 5.9** Mass flow through two processes with recycle.

There are two material balance equations and three mass specifications

*Material balance*

- 1)  $X_1 + X_4 - X_2 - X_3 = 0$
- 2)  $X_3 - X_4 - X_5 = 0$

*Mass specifications*

- 3)  $X_3 = 0.7(X_1 + X_4) = 0.7(1000 + X_4) = 700 + 0.7 X_4$
- 4)  $X_5 = 0.95 X_3 = 0.95(700 + 0.7 X_4) = 665 + 0.665 X_4$
- 5)  $X_1 = 1000$

The simultaneous solution of equations 2, 3 and 4 gives:

$$(700 + 0.7 X_4) - X_4 - (665 + 0.665 X_4) = 0$$

$$0.965 X_4 = 35$$

$$X_4 = 36.27$$

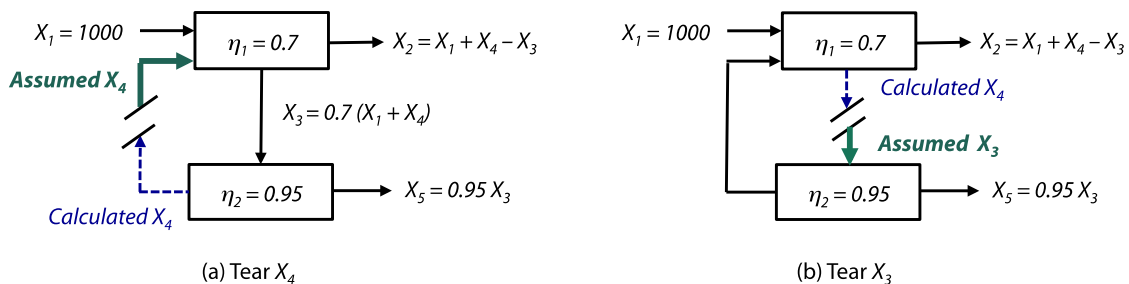
From Eq. 5  $X_5 = 665 + 0.665(36.27) = 689.1$

From Eq. 2  $X_3 = X_4 + X_5 = 36.27 + 689.1 = 725.4$

From Eq. 1  $X_2 = 1000 + 36.27 - 725.4 = 310.9$

Start by assuming a value for one variable. In this example  $X_2$ ,  $X_3$ ,  $X_4$  or  $X_5$  could be assumed, but the ease of calculation usually depends on which variable is selected. Often you know more about one variable than the others and this knowledge will help estimate a workable starting value. If a variable must be within a certain range, that variable is a good one to assume.

There are several possible iterative solutions. One is to tear variable  $X_4$  as shown in Figure 5.10(a), and another is to tear  $X_2$  as shown in Figure 5.10(b).



**Figure 5.10** Information flow diagrams where  $X_3$  or  $X_4$  is the tear variable.

The iterative solution will be illustrated using  $X_3$  as the tear variable, starting with an assumed value of  $X_3 = 700$ . This amounts to neglecting the recycle to get started. (It is equivalent to assuming  $X_4 = 0$ .)

$$\begin{aligned} \text{Eq. 4} \quad & X_5 = 0.95 X_3 = 0.95(700) = 665 \\ \text{Eq. 2} \quad & X_4 = X_3 - X_5 = 700 - 665 = 35 \\ \text{Eq. 1} \quad & X_2 = X_1 + X_4 - X_3 = 1000 + 35 - 700 = 335 \\ \text{Eq. 3 - Solve for } X_3 & X_3 = 0.7(X_1 + X_4) = 0.7(1000 + 35) = 724.5 \\ & \text{Assumed and calculated values do not agree.} \end{aligned}$$

2<sup>nd</sup> Iteration – Assume  $X_3 = 724.5$

$$\begin{aligned} \text{Eq. 4} \quad & X_5 = 0.95 X_3 = 0.95(724.5) = 688.3 \\ \text{Eq. 2} \quad & X_4 = X_3 - X_5 = 724.5 - 688.3 = 36.2 \\ \text{Eq. 1} \quad & X_2 = X_1 + X_4 - X_3 = 1000 + 36.2 - 724.5 = 311.7 \\ \text{Eq. 3 - Solve for } X_3 & X_3 = 0.7(X_1 + X_4) = 0.7(1000 + 36.2) = 725.3 \\ & \text{Assumed and calculated values agree.} \end{aligned}$$



Join the best at  
the Maastricht University  
School of Business and  
Economics!

Top master's programmes

- 33<sup>rd</sup> place Financial Times worldwide ranking: MSc International Business
- 1<sup>st</sup> place: MSc International Business
- 1<sup>st</sup> place: MSc Financial Economics
- 2<sup>nd</sup> place: MSc Management of Learning
- 2<sup>nd</sup> place: MSc Economics
- 2<sup>nd</sup> place: MSc Econometrics and Operations Research
- 2<sup>nd</sup> place: MSc Global Supply Chain Management and Change

Sources: Keuzegids Master ranking 2013; Elsevier 'Beste Studies' ranking 2012; Financial Times Global Masters in Management ranking 2012

Maastricht University is the best specialist university in the Netherlands (Elsevier)

Visit us and find out why we are the best!  
Master's Open Day: 22 February 2014

[www.mastersopenday.nl](http://www.mastersopenday.nl)

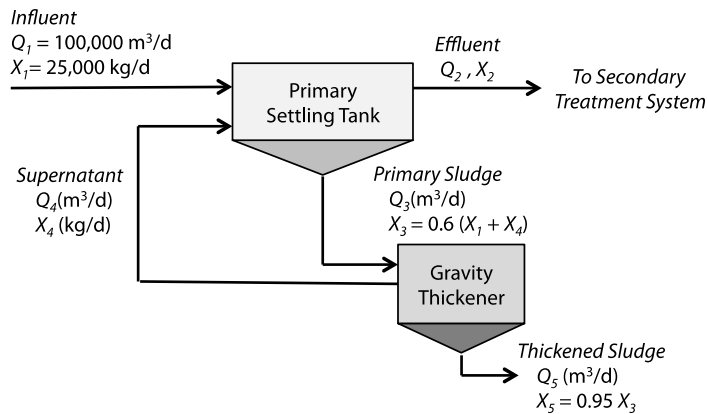


Click on the ad to read more



**Example 5.7 SUPERNATANT RECYCLE FROM A SLUDGE THICKENER RECYCLE**

Figure 5.11 shows a portion of a wastewater treatment plant that has the same structure as the hypothetical system in Figure 5.10.



**Figure 5.11** Primary settling tank sludge is concentrated in a gravity thickener. Supernatant from the thickener is recycled to the primary settling tank.

The settling tank influent is 100,000 m<sup>3</sup>/d (26.4 mgd) with a total suspended solids concentration of 0.25 kg/m<sup>3</sup> (250 mg/L). This is a total suspended solids load of (100,000 m<sup>3</sup>/d)(0.25 kg/m<sup>3</sup>) = 25,000 kg/d. The settling tank removes 60% of the influent solids and delivers sludge at a concentration of 2% and specific gravity = 1.02 to a gravity sludge thickener. The sludge thickener concentrates this sludge to 6.5% at specific gravity = 1.03. The thickener captures 95% of the influent solids as thickened sludge and returns 5% of the solids to the settling tank as supernatant.

When the solids qualities are known the volume flow rates can be calculated.

*Material balance on solids*

Settling tank: (1)  $X_1 + X_4 = X_2 + X_3$

Sludge thickener (2)  $X_3 = X_4 + X_5$

*Mass specifications:* (3)  $X_3 = 0.6(X_1 + X_4)$

(4)  $X_5 = 0.95 X_3$

(5)  $X_1 = 25,000$

There are  $F = 0$  degrees of freedom. The iterative solution that corresponds to Figure 5.18 is to assume a value for  $X_3$ . If the supernatant adds no solids to the settling tank load,  $X_3 = 0.6(25,000) = 15,000$ . This could be used as a starting value, but we know the quantity will be more than 15,000 so we will try  $X_3 = 15,500$ .

*First Iteration – Assume  $X_3$*   $X_3 = 15,500$   
 Eq. 4  $X_5 = 0.95 X_3 = 0.95(15,500) = 14,725$   
 Eq. 2  $X_4 = X_3 - X_5 = 15,000 - 14,725 = 275$   
 $X_2 = X_1 + X_4 - X_3 = 25,000 + 275 - 15,500 = 9775$   
 Calculate new value for  $X_3$ :  $X_3 = 0.6(X_1 + X_4) = 0.6(25,000 + 275) = 15,165$

*Second Iteration – Assume  $X_3$*   $X_3 = 15,165$   
 $X_5 = 0.95(15,165) = 14,407$   
 $X_4 = 15,165 - 14,407 = 758$   
 $X_2 = 25,000 + 758 - 15,165 = 10,593$   
 Calculate new value for  $X_3$ :  $X_3 = 0.6(25,000 + 758) = 15,445$





The *structure* of a system of equations refers to how the variables participate in the design relations. This can be shown in the *structural array*, which contains the same information as the diagram in Figure 5.6. The structural array is more convenient as the number of variables and equations increases.

Figure 5.13 is the *structural array* for the five equations from Figure 5.5. In this simple system, 70% of the feed captured in process 1 is directed into process 2, where 95% of the feed is captured as product and 5% is lost was waste. There  $N = 5$  equations with  $M = 5$  variables.

- 1)  $X_1 = 1000$  (Basis)
- 2)  $X_1 - X_2 - X_3 = 0$
- 3)  $X_3 - X_4 - X_5 = 0$
- 4)  $X_3 = 0.7 X_1$
- 5)  $X_5 = 0.95 X_3$

There  $N = 5$  equations with  $M = 5$  variables. Specifying the basis,  $X_1 = 1000$ , consumed one degree of freedom, leaving  $N = M = 4$  and  $X_2, X_3, X_4$  and  $X_5$  as unknowns.  $N = M$  means there is a unique solution. We want the calculations to be as easy as possible, and that means using a precedence order, if one exists.

> **Apply now**

REDEFINE YOUR FUTURE  
**AXA GLOBAL GRADUATE  
PROGRAM 2015**

redefining / standards 

agence.cdg. © Photonistop



The structural array, Figure 5.13, has a row for each equation and a column for each variable. Dots in the columns show how the variables participate in the equations. For example, equation 2 uses variables  $X_1$ ,  $X_2$  and  $X_3$ . Shading will be added to indicate which variables are known (shaded) and unknown (unshaded). The four panels in the diagram show the progress in the structural analysis.

The basis,  $X_1 = 1000$ , is given so the column for  $X_1$  in Figure 5.13b is shaded to indicate that the value is known.

A row (equation) that has one unshaded dot (unknown variable) can be solved using the information at hand, namely  $X_1 = 1000$ . Such a row is equation 4.

$$X_3 = 0.7 X_1$$

$$X_3 = 0.7(1000) = 700$$

Shade the row for equation 4 and the column for  $X_3$  to indicate Eq. 4 has been used and  $X_3$  is known. This is Figure 5.13c.

Rows (equations) 2 and 5 now contain a single dot (variable). The next calculation can be  $X_2$  from equation 2 and  $X_5$  from equation 5. The final calculation is  $X_4$  from equation 3.

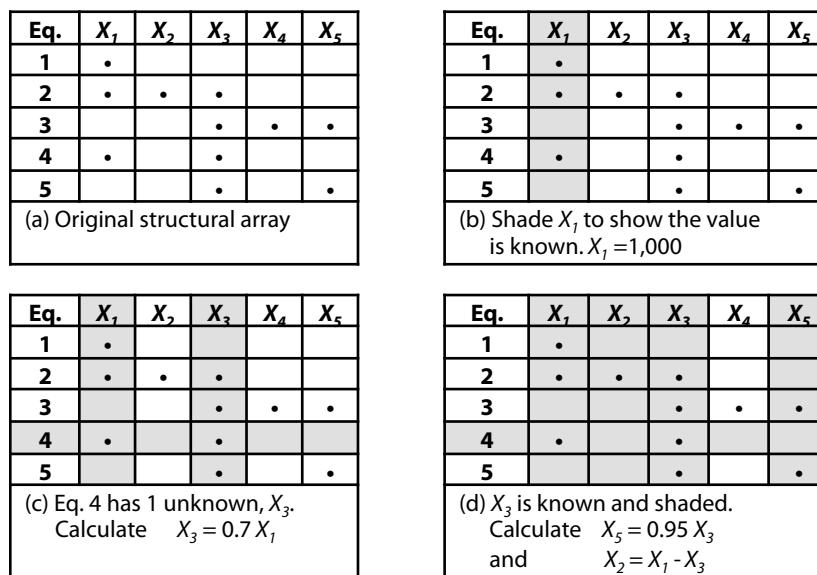


Figure 5.13. Structural array is used to analyze the equations for the system in Figure 5.5.

Very often the precedence order is not unique. The important result is finding a sequence of the needed information flow from one equation to the next, so they can be solved one by one. In this case, two sequences have been discovered.

In this case, two sequences have been discovered.

$$\begin{aligned} \text{Eq. 4} \quad X_3 &= 0.7 X_1 & X_3 &= 0.7(1000) = 700 \\ \text{Eq. 5} \quad X_5 &= 0.95 X_3 & X_5 &= 0.95(700) = 665 \\ \text{Eq. 2} \quad X_2 &= X_1 - X_3 & X_2 &= 1000 - 700 = 300 \\ \text{Eq. 3} \quad X_4 &= X_3 - X_5 & X_4 &= 700 - 665 = 35 \end{aligned}$$

and

$$\begin{aligned} \text{Eq. 4} \quad X_3 &= 0.7 X_1 & X_3 &= 0.7(1000) = 700 \\ \text{Eq. 5} \quad X_5 &= 0.95 X_3 & X_5 &= 0.95(700) = 665 \\ \text{Eq. 3} \quad X_4 &= X_3 - X_5 & X_4 &= 700 - 665 = 35 \\ \text{Eq. 2} \quad X_2 &= X_1 - X_3 & X_2 &= 1000 - 700 = 300 \end{aligned}$$

The algorithm we used to analyze the structural array can be run in reverse to select design variables that create a precedence order, when one exists. Figure 5.14 is used to illustrate the procedure.

Figure 5.14 shows a simple system with  $M = 7$  variables,  $N = 3$  material balance equations, and  $F = 7 - 3 = 4$  degrees of freedom. Assume that  $X_1$  and  $X_5$  are specified by external conditions, say  $X_1 = 100$  and  $X_5 = 2$ . This reduces the degrees of freedom from 4 to 2. It does matter which two variables are selected as design variables.

We start with  $X_1$  and  $X_5$  shaded out because they cannot be design variables. The purpose of the new column will become apparent as we run through the design variable selection algorithm.

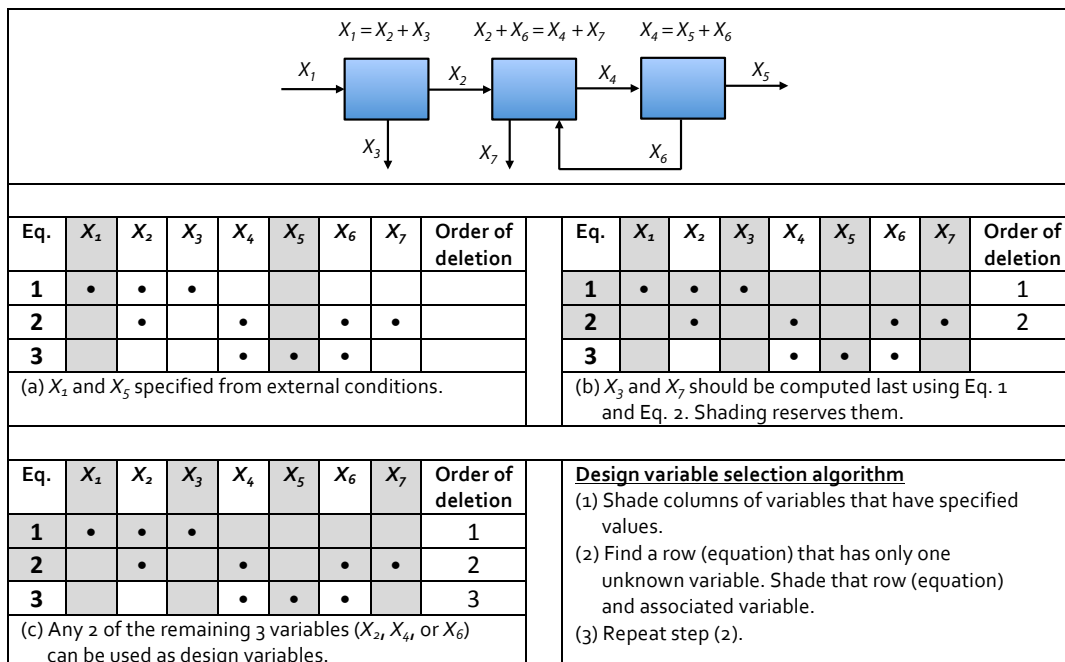



Figure 5.14 Design variable selection algorithm applied to Example 5.5, which has  $N = 3$ ,  $M = 7$  and  $F = 4$ .

One dot in a column identifies a variable that participates in only one equation. That variable should not be a design variable; it should be calculated later. Shade it out to protect it, along with the equation that will be used to calculate it. We can shade out  $X_3$  and  $X_7$ . Arbitrarily we select  $X_3$  and equation 1 to shade out first, and  $X_7$  with equation 2 second. (The reverse is equally good.) Keep track of the deletions in the column labeled 'Order of deletion'.

Any two of the unshaded variables, that is  $X_2$ ,  $X_4$  or  $X_6$  can be the design variables. Select one and delete equation 3.

The order of solving the equation is the reverse of the order in which they were deleted. Solve Eq. 3, then Eq. 2, and then Eq. 1. (Or, you could do Eq. 3, Eq. 1 and Eq. 2.)

It may happen, at some point in the algorithm, that all columns have two or more dots. This indicates information recycle that cannot be untangled simply by making an intelligent selection of design variables. There is no precedence order. Figure 5.15 is an example.  $X_1$  and  $X_5$  are known from external conditions.  $X_3$  is identified as a variable that should be calculated last, using equation 1. The algorithm can take us no further toward a precedence order. All remaining variables participate in two equations. Any two of  $X_2$ ,  $X_4$ ,  $X_6$  or  $X_7$  can be used as design variables. There may be some feature of the equations that makes one selection more attractive than another, but whatever the choice the solution will involve iteration or simultaneous equations.



**Empowering People. Improving Business.**

BI Norwegian Business School is one of Europe's largest business schools welcoming more than 20,000 students. Our programmes provide a stimulating and multi-cultural learning environment with an international outlook ultimately providing students with professional skills to meet the increasing needs of businesses.

BI offers four different two-year, full-time Master of Science (MSc) programmes that are taught entirely in English and have been designed to provide professional skills to meet the increasing need of businesses. The MSc programmes provide a stimulating and multi-cultural learning environment to give you the best platform to launch into your career.

- MSc in Business
- MSc in Financial Economics
- MSc in Strategic Marketing Management
- MSc in Leadership and Organisational Psychology

**BI NORWEGIAN BUSINESS SCHOOL**

EFMD **EQUIS ACCREDITED**

[www.bi.edu/master](http://www.bi.edu/master)



Eq.	$X_1$	$X_2$	$X_3$	$X_4$	$X_5$	$X_6$	$X_7$	Order of deletion
1	•	•	•					1
2		•		•		•	•	
3		•		•	•	•	•	
There is no precedence order								

Figure 5.15. A structural array that fails to yield a precedence order.

## 5.8 Computer-Aided Design

The concepts in this book are illustrated with examples that can be analyzed using simple algebra. Paper and pencil solutions with hand-drawn diagrams are often the best way to clarify concepts and stimulate new process arrangements. But, it is true that many problems benefit from more powerful methods, especially processes that can be arranged in many combinations and large systems with many pollutants and material recycle.

These are some of the available software systems.

CapdetWorks – Accurate and rapid preliminary design and cost estimating for wastewater treatment plant construction projects Extensive research went into checking and obtaining updated costs for all of the equipment and unit costs that are required when designing wastewater treatment plants. Costs were obtained from suppliers and manufacturers throughout North America (Hydromantis 2014, [www.hydromantis.com](http://www.hydromantis.com)).

Toxchem – Drag-and-drop creation of virtually any treatment plant configuration of unit processes with state-of-the-art models to simulate different volatilization, adsorption and biodegradation mechanisms. Toxchem includes a comprehensive contaminants database for compounds that are regulated by the U.S.EPA (Hydromantis 2014, [www.hydromantis.com](http://www.hydromantis.com)).

GPS-X – A modular, multi-purpose computer program for the modeling and simulation of municipal and industrial wastewater treatment plants. Whether you are designing a new facility, or simulating an existing plant, GPS-X will help you improve your design and operating efficiency. The software can be used, for example, to investigate the impact of increased organic and hydraulic loading on an existing plant, verify plant capacity under different loading conditions, temperatures and or operating strategies, compare alternatives for retrofitting an existing process and assess different diffused aeration design (e.g., diffuser design, taper and DO control), and investigate cost savings for proposed changes in process operation (Hydromantis 2014, [www.hydromantis.com](http://www.hydromantis.com)).

Aspen Plus is a comprehensive chemical process modeling system that is used to design and improve processing plants. Uses pinch technology to improve the efficiency of heat exchange energy systems (see chapters 8 and 11). (Aspen Technology Aspen Technology 2013)

Super Pro Design facilitates modeling, evaluation and optimization of integrated processes in a wide range of industries, including water purification, wastewater treatment, and air pollution control. Manufacturing and environmental operation models can be handled in the same package to concurrently design and evaluate manufacturing and end-of-pipe treatment processes and practice waste minimization via pollution prevention as well as pollution control. The software includes models for more than 140 unit operations. (Petrides 2014, Intelligen: [www.intelligen.com](http://www.intelligen.com))

## 5.9 Conclusion

Two interesting problems are (1) those that require an iterative solution, which includes many processes that use recycle, and (2) optimization problems, in which the designer can evaluate different solutions by manipulating one or more design variables.

An evaluation of the degrees of freedom of a problem and an understanding of the information flow from equation to equation is always helpful. Simple problems do not need this kind of attention, but many real designs involve dozens of equations and many variables. This chapter has introduced some of the tools that will be useful.



# 6 Material Balance with Chemical Reactions

## 6.1 The Design Problem

The interesting design problems go beyond mixing, splitting, or separating streams of non-reactive materials. More often chemical and biological transformations are used to make materials easy to separate from a bulk flow, or to make them safe for discharge. Chemical reagents are added or active biological agents (e.g. bacteria) are cultivated to initiate or accelerate the transformation.

The material balance must account for whatever is added and whatever is created or destroyed by chemical or biochemical reactions.

The rate at which the chemistry occurs is relevant for reactor design, which is selecting the reactor shape, mixing, operating conditions (pH, temperature, oxygen levels, etc.) and calculating the reactor volume and detention time. In this book we are concerned only with the extent of conversion or transformation, not with the speed of the reaction or physical details about the reactor. If a waste gas containing benzene is burned in a catalytic converter, the conversion of benzene to carbon dioxide happens in one second. The same oxidation may take an hour or more if it happens in a biological waste treatment process. To make the material balance we need to know, for example, that 99% of benzene that enters a reactor (whatever its internal details) is converted to carbon dioxide.

## 6.2 Material Balances with Chemical Reactions

The material balance, modified to account for chemical reactions, is

$$\left[ \begin{array}{c} \text{rate of inflow} \\ \text{of species } i \end{array} \right] - \left[ \begin{array}{c} \text{rate of outflow} \\ \text{of species } i \end{array} \right] + \left[ \begin{array}{c} \text{rate of} \\ \text{formation} \\ \text{of species } i \end{array} \right] = \left[ \begin{array}{c} \text{rate of} \\ \text{destruction} \\ \text{of species } i \end{array} \right] + \left[ \begin{array}{c} \text{rate of} \\ \text{accumulation} \\ \text{of species } i \end{array} \right]$$

Applying the concept over a stated period of time, say one minute, an hour, or a day, gives

$$\left[ \begin{array}{c} \text{mass inflow} \\ \text{of species } i \end{array} \right] - \left[ \begin{array}{c} \text{mass outflow} \\ \text{of species } i \end{array} \right] + \left[ \begin{array}{c} \text{mass of species } i \\ \text{formed} \\ \text{by reaction} \end{array} \right] = \left[ \begin{array}{c} \text{mass of species } i \\ \text{destroyed} \\ \text{by reaction} \end{array} \right] + \left[ \begin{array}{c} \text{accumulated} \\ \text{mass of species } i \end{array} \right]$$

The reference to *species i* indicates the need to keep track of the kinds and amounts of molecules and substances that are moved around and transformed. Atoms, of course, are not destroyed; they are just rearranged as molecules are broken apart and elements are recombined into new species. The material balance keeps track of what happens.

If common salt (NaCl) is added to water as it enters a reactor, the salt will dissolve into sodium ions ( $\text{Na}^+$ ) and chloride ions ( $\text{Cl}^-$ ). This is a simple change in physical form and not a chemical reaction, but the material balance must keep track of chloride. The mass of chloride going in equals the amount of coming out. The same must be for sodium. But it is not true for NaCl, the undissolved chemical compound, which may not exist in the effluent.

In a similar way, calcium chloride ( $\text{CaCl}_2$ ) will dissolve in water to give one calcium ( $\text{Ca}^{2+}$ ) and two chloride ions ( $\text{Cl}^-$ ). The chloride will exist as dissolved ions. If the water contains carbonate ( $\text{CO}_3^{2-}$ ) or sulfate ( $\text{SO}_4^{2-}$ ), some fraction of the calcium may form  $\text{CaSO}_4$  or  $\text{CaCO}_3$ , which are solids. The material balance must account for calcium in all the species where it may be found. The mass of calcium is conserved and the moles of calcium is conserved. The mass of  $\text{CaCl}_2$  is not.

The chemical reactants and products, and the masses of materials converted and produced, are described by a stoichiometric equation. When there is one or more reaction, add these steps to the guidelines in section 4.3 for organizing the material balance equations.

1. Write a separate stoichiometric equation for each reaction.
2. Do not include more than one reaction in an equation.
3. Calculate the mass of each reactant and product on the basis of the chemical reaction.

## Need help with your dissertation?

Get in-depth feedback & advice from experts in your topic area. Find out what you can do to improve the quality of your dissertation!

Get Help Now



Go to [www.helpmyassignment.co.uk](http://www.helpmyassignment.co.uk) for more info

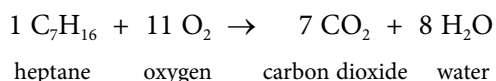
 **Helpmyassignment**

A brief explanation of this will be given. Readers who understand how to read a chemical reaction equation may wish to skip this section.

### 6.3 Reaction Stoichiometry

*Stoichiometry* is the science of deciphering chemical 'sentences' that give the end points of a chemical reaction. The sentence contains both qualitative and quantitative information.

This is the stoichiometric equation for the reaction of heptane ( $C_7H_{16}$ ) with oxygen ( $O_2$ ) to produce carbon dioxide ( $CO_2$ ) and water ( $H_2O$ ). By convention reactants are on the left and products are on the right.



The reaction equation gives the definite molecular proportions of the reaction. The stoichiometric coefficients (1 for heptane, 11 for oxygen, and so on) refer to molecular units. One heptane molecule reacts with eleven oxygen molecules to produce seven carbon dioxide molecules and eight water molecules.

The stoichiometry shows how many atoms are involved and how they are rearranged. The 7 carbon atoms in the heptane are incorporated into carbon dioxide. The hydrogen from the heptane appears in the water. The 22 atoms of oxygen appear as carbon dioxide ( $2 \times 7 = 14$  atoms) and water (8 atoms).

This is a *balanced reaction* because the number of carbon atoms in the reactants (left side) is the same as in the products (right side), and the same is true for the numbers of hydrogen and oxygen atoms.

The number of moles of products and reactants do not usually balance. Burning heptane (above) shows 12 moles of reactants forming 15 moles of products.

The balanced reaction equation is also a statement of the mass balance because the *masses* of reactants on the left side must equal the masses of products on the right. But the stoichiometric coefficients indicate moles of material. They do not directly indicate the masses involved. Because of this, the key to deciphering the reaction stoichiometry is the conversion of molecular units to mass units.

A *mole* is a measure of the number of atoms, molecules, or other specified particles. One *gram mole* (g-mole) contains about  $6 \times 10^{23}$  molecules, and one *pound mole* (lb-mole) contains about  $2.7 \times 10^{28}$  molecules.

The mole unit is defined as the mass of material divided by its *molecular mass*.

$$\text{g-mole} = \text{mass in grams per molar mass}$$

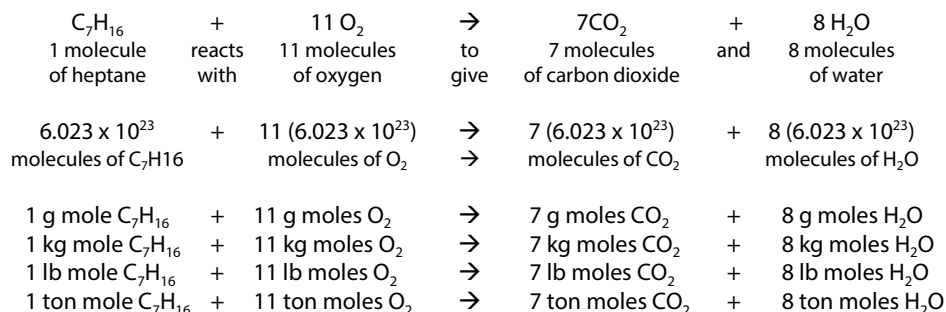
$$\text{lb-mole} = \text{mass in pounds per molar mass}$$

and so forth in any mass unit we wish to use.

The *molar mass* of a compound is assembled merely by summing the atomic masses of its constituents.

**Example 6.1 BURNING HEPTANE**

The reaction for the burning of heptane is



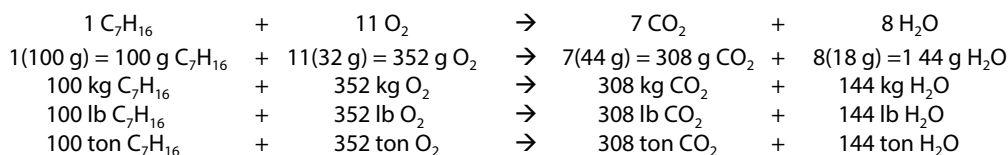
Use the molar mass of each compound to convert from a molar basis to a mass basis.

The atomic masses are C = 12, H = 1, and O = 16.

The molar masses are the sum of the atomic masses in the molecule:

$$\begin{aligned}
 C_7H_{16} &= 7(12) + 16(1) = 100 \text{ g/g mole} = 100 \text{ lb/lb mole} = 100 \text{ ton/ton mole} \\
 CO_2 &= 1(12) + 2(16) = 44 \text{ g/g mole} = 44 \text{ lb/lb mole} = 44 \text{ ton/ton mole} \\
 O_2 &= 2(16) = 32 \text{ g/g mole} = 32 \text{ lb/lb mole} = 32 \text{ ton/ton mole} \\
 H_2O &= 2(1) + 16 = 18 \text{ g/g mole} = 18 \text{ lb/lb mole} = 18 \text{ ton/ton mole}
 \end{aligned}$$

The mass in grams of substance reacting is calculated by multiplying the molar mass (grams per g-mole) of each substance by the number of moles. The proportions of reactants and products hold for any mass units.



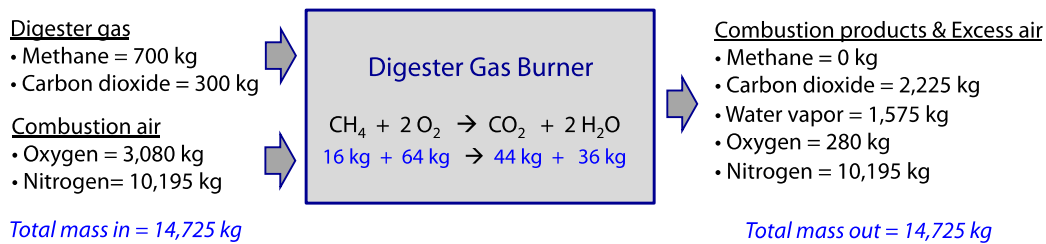
Notice that the mass of all reactants equals the mass of all products formed: 452 g of reactants yield 452 g of products.

**Example 6.2 BURNING SLUDGE DIGESTER GAS (METHANE)**

*Digester gas or biogas* is produced by anaerobic treatment of high-strength organic industrial wastewaters (e.g., food and brewing industries), municipal sewage sludge, agricultural waste (manure), and waste decomposition in landfills.

A municipal sludge digester produces gas that is about 70% methane (CH<sub>4</sub>) and 30% carbon dioxide (CO<sub>2</sub>), plus traces of other gases. This gas has about seventy percent the fuel value of natural gas and can be burned to heat processes or buildings, or to drive motors connected to electric generators, pumps, or blowers.

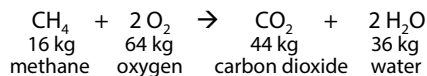
Calculate the material balance on the gases and water vapor entering and leaving the burner. Figure 6.1 shows the inputs and outputs of the combustion chamber. The entering nitrogen is unchanged in the burner and is not included in the stoichiometric equation.



**Figure 6.1** Combustion of gas from an anaerobic digester.

The *basis* will be an input of 1000 kg of dry digester gas, which contains 700 kg methane (70%) and 300 kg carbon dioxide (30%).

The combustion of methane produces carbon dioxide according to



That is  $16 \text{ kg CH}_4 + 64 \text{ kg O}_2 \rightarrow 44 \text{ kg CO}_2 + 36 \text{ kg H}_2\text{O}$

*Methane* (CH<sub>4</sub>) is completely combustible so its material balance is

$$700 \text{ kg input} = \left[ \begin{array}{l} 700 \text{ kg destroyed in} \\ \text{combustion reaction} \end{array} \right] + \left[ \begin{array}{l} 0 \text{ kg output in} \\ \text{exhaust gas} \end{array} \right]$$

*Carbon Dioxide* (CO<sub>2</sub>). The balanced chemical equation shows that 16 kg of methane burned produces 44 kg of carbon dioxide. Burning 700 kg methane yields

$$X = \left[ 700 \text{ kg CH}_4 \right] \left[ \frac{44 \text{ kg CO}_2}{16 \text{ kg CH}_4} \right] = 1,925 \text{ kg CO}_2 \text{ produced}$$

The material balance on carbon dioxide is

$$\left[ 300 \text{ kg input} \right] + \left[ \begin{array}{l} X \text{ kg produced} \\ \text{by combustion} \end{array} \right] = \left[ \begin{array}{l} \text{output with} \\ \text{exhaust gas} \end{array} \right]$$

$$300 \text{ kg} + 1925 \text{ kg} = 2,225 \text{ kg CO}_2$$

*Oxygen (O<sub>2</sub>).* Oxygen is supplied by blowing air into the burner chamber. Ten percent excess is provided to insure complete combustion. The stoichiometric requirement for oxygen is 64 kg oxygen for every 16 kg of methane burned, or four parts oxygen per part of methane. This gives

Stoichiometric demand: Burning 700 kg methane consumes  $4(700 \text{ kg}) = 2,800 \text{ kg}$  oxygen.  
 10% excess = 280 kg  
 Total input =  $2,800 + 280 = 3,080 \text{ kg}$   
 O<sub>2</sub> in exhaust gas =  $3,080 - 2,800 = 280 \text{ kg}$

*Nitrogen (N<sub>2</sub>)* is an inert gas that enters with the supplied air and exits, unreacted, in the exhaust gases. Air is 76.8% nitrogen and 23.2% oxygen by weight so each unit of oxygen brings along  $76.8/23.2 = 3.31$  units of nitrogen. The nitrogen carried into the burner with the 3,080 kg of oxygen will be  $(3.31)(3,080 \text{ kg}) = 10,195 \text{ kg}$  nitrogen. The same mass leaves in the exhaust gas.

*Water.* The digester gas and the incoming air will contain some water vapor. This may be important in an energy balance, because it will have to be heated in the gas burner, but it can be ignored in this example. The mass of water produced by the combustion is  $(700)(36/16) = 1,575 \text{ kg}$ . It leaves as vapor in the exhaust gas.

In summary, assuming dry digester gas and dry input air, the material balance is

	Input		Produced		Output		Destroyed
Methane (CH <sub>4</sub> )	700	+	0	=	0	+	700
Carbon dioxide (CO <sub>2</sub> )	300	+	1,925	=	2,225	+	0
Oxygen (O <sub>2</sub> )	3,080	+	0	=	280	+	2800
Nitrogen (N <sub>2</sub> )	10,195	+	0	=	10,195	+	0
Water vapor (H <sub>2</sub> O)	0	+	1,575	=	1,575	+	0

**Brain power**

By 2020, wind could provide one-tenth of our planet's electricity needs. Already today, SKF's innovative know-how is crucial to running a large proportion of the world's wind turbines.

Up to 25 % of the generating costs relate to maintenance. These can be reduced dramatically thanks to our systems for on-line condition monitoring and automatic lubrication. We help make it more economical to create cleaner, cheaper energy out of thin air.

By sharing our experience, expertise, and creativity, industries can boost performance beyond expectations. Therefore we need the best employees who can meet this challenge!

**The Power of Knowledge Engineering**

Plug into The Power of Knowledge Engineering.  
Visit us at [www.skf.com/knowledge](http://www.skf.com/knowledge)

**SKF**

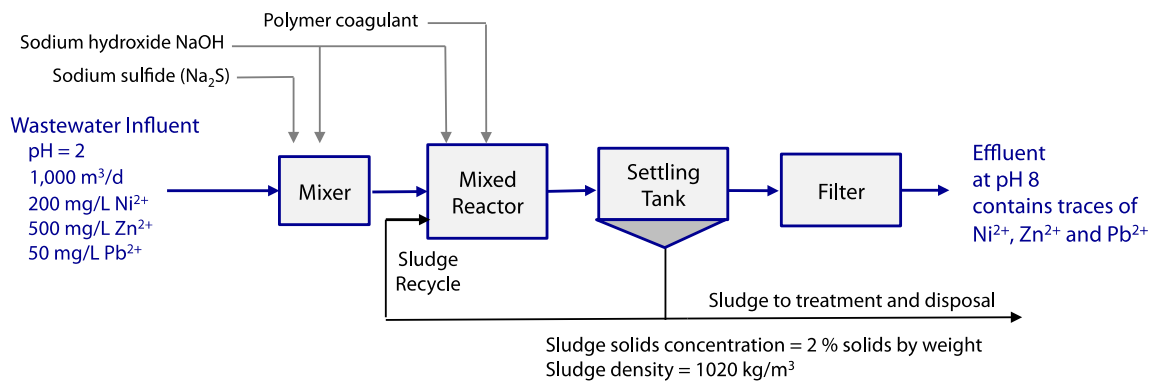


## 6.4 Case Study – Chemical Precipitation of Metals

Acidic wastewater (pH 2) from a metal fabricating shop contains 200 mg/L Nickel (Ni), 500 mg/L Zinc (Zn), and 50 mg/L Lead (Pb). These are total concentrations and the metals are 100% soluble at the acidic feed conditions. The wastewater flow is 1,000 m<sup>3</sup>/d.

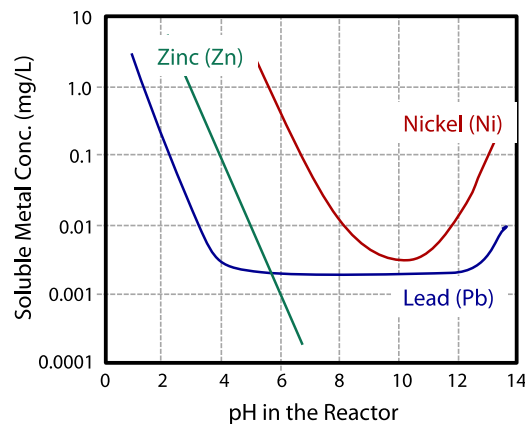
The metals can be precipitated as sulfides (NiS, ZnS, and PbS) by adding a soluble form of sulfide (S<sup>2-</sup>). Sodium sulfide (Na<sub>2</sub>S) will be used. The reactor will operate at pH 8 and sodium hydroxide (NaOH) will be added to neutralize the acidic influent. A polymer is also added to coagulate the fine sulfide precipitates and facilitate separation by settling and filtration. The process is shown in the block diagram of Figure 6.2.

The sludge density will be 1,020 kg/m<sup>3</sup> and the solids concentration will be 2% by weight (20 kg dry solids/m<sup>3</sup> wet sludge).



**Figure 6.2** Block diagram of a process to remove lead, zinc, and nickel as a solid sulfide precipitate by adjusting the wastewater pH and adding sodium sulfide. The mass of metals in the effluent and in the filter washwater are important environmentally, but are negligible in the mass balance. Therefore, the calculations assume that all the metals precipitate and are removed as sludge from the settler.

Figure 6.3 shows how the solubility of the metals depends on the pH of the wastewater (Lewis 2010). The difficult problem of calculating the minimum solubility is not discussed here. Empirical data from the graph will be used.



**Figure 6.3** Solubility of Lead (Pb), Zinc (Zn), and Nickel (Ni) as a function of pH (adapted from Lewis 2010).

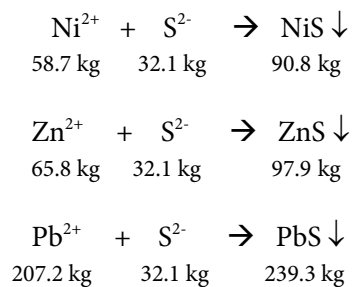


The maximum amount of all three metals will be removed if the reactor operates at pH 10, but an effluent of pH 10 would have to be brought into the range of 6-9 before discharge. Operating at pH 8 is a better choice, with an expected effluent quality of Zn = negligible, Ni = 0.01 mg/L and Pb = 0.002 mg/L.

For comparison, the human health water quality criteria are 0.61 mg/L Ni, 7.4 mg/L Zn, and 0 mg/L Pb. The acute aquatic life criteria for freshwater are 0.47 mg/L Ni, 0.12 mg/L Zn, and 0.065 mg/L Pb.

There are two obstacles to achieving these effluent levels. The first is that the precipitation reaction may not reach equilibrium. That is, the concentration of soluble metal may be higher than predicted by Figure 6.3. Second, the separation process may not remove all of the precipitate solids. A polymer is added to agglomerate the small solids so they are easier to remove, but 100% removal is unlikely. One reference says that the estimated achievable 30-day average for sulfide precipitation followed by filtration is 0.02 mg/L Zn, 0.1 mg/L Ni, and 0.05 mg/L Pb (Whang 2005).

The stoichiometry is simple. One atom of metal combines with one atom of sulfide. (The atomic and molecular masses are rounded to one decimal place.)



The superscripts indicate the ionic charge of the ions. Negative and positive ions combine to form neutral solids. Ions have the same atomic mass as the unionized atoms.

The arrow ( $\downarrow$ ) indicates a solid species that can be removed by settling or filtration. The details of the separation are omitted except to say that the treated water contains a negligible mass of particulate metal sulfides and the removed metals are contained in a sludge that has 2% solids concentration (2 kg dry solids per 100 kg of sludge) and a density of 1020 kg/m<sup>3</sup>.

Some empirical stoichiometry is needed to account for precipitates, such as calcium sulfate and iron hydroxides, that will form simultaneously with the sulfides. Experiments indicate that 2 kg of non-sulfide precipitates will be formed for each cubic meter of wastewater treated.

Assumptions:

- 1) The estimated volume and mass of sludge are nearly the same whether the final effluent concentration of zinc is 0.01mg/L or 0.1 mg/L. Sludge quantities will be calculated as though all the metals have been removed.
- 2) The mass of solids removed in the filter is negligible compared with the amount removed in the settler. Therefore, the sludge quantities are calculated assuming 100% of the solids are in the settler sludge.

The basis for material balance is 1,000 m<sup>3</sup>.

Mass of metals in the wastewater feed

$$\text{Mass Ni} = (1000 \text{ m}^3)(0.2 \text{ kg/m}^3) = 200 \text{ kg}$$

$$\text{Mass Zn} = (1000 \text{ m}^3)(0.8 \text{ kg/m}^3) = 800 \text{ kg}$$

$$\text{Mass Pb} = (1000 \text{ m}^3)(0.05 \text{ kg/m}^3) = 50 \text{ kg}$$



What do you want to do?

No matter what you want out of your future career, an employer with a broad range of operations in a load of countries will always be the ticket. Working within the Volvo Group means more than 100,000 friends and colleagues in more than 185 countries all over the world. We offer graduates great career opportunities – check out the Career section at our web site [www.volvogroup.com](http://www.volvogroup.com). We look forward to getting to know you!

**VOLVO**  
AB Volvo (publ)  
[www.volvogroup.com](http://www.volvogroup.com)

VOLVO TRUCKS | RENAULT TRUCKS | MACK TRUCKS | VOLVO BUSES | VOLVO CONSTRUCTION EQUIPMENT | VOLVO PENTA | VOLVO AERO | VOLVO IT  
VOLVO FINANCIAL SERVICES | VOLVO 3P | VOLVO POWERTRAIN | VOLVO PARTS | VOLVO TECHNOLOGY | VOLVO LOGISTICS | BUSINESS AREA ASIA



Formation of particulate metal sulfides

Nickel sulfide:  $90.8 \text{ kg NiS} / 58.7 \text{ kg Ni} = 1.55 \text{ kg NiS/kg Ni}$

$$(200 \text{ kg Ni})(90.8 \text{ kg NiS} / 58.7 \text{ kg Ni}) = 309.4 \text{ kg NiS}$$

Zinc sulfide  $(800 \text{ kg Zn})(97.9 \text{ kg ZnS} / 65.8 \text{ kg Zn}) = 1,190.3 \text{ kg ZnS}$

Lead sulfide:  $(50 \text{ kg Pb})(239.3 \text{ kg PbS} / 207.2 \text{ kg Pb}) = 57.7 \text{ kg PbS}$

$$M_s = \text{Metal sulfide precipitates} = 309.4 + 1,190.3 + 57.7 = 1,557 \text{ kg (rounded)}$$

$$M_{\text{other}} = \text{Mass of other precipitates} = (2 \text{ kg/m}^3)(1,000 \text{ m}^3) = 2,000 \text{ kg}$$

Sludge mass and volume

$$\text{Total mass of solids in sludge} = M_s + M_{\text{other}} = 3,557 \text{ kg}$$

$$\text{Mass of sludge, at 2\% solids} = 3,557 / 0.02 = 177,850 \text{ kg}$$

$$\text{Sludge density} = 1,020 \text{ kg/m}^3$$

$$\text{Volume of sludge} = 177,850 \text{ kg} / 1020 \text{ kg/m}^3 = 174 \text{ m}^3 \text{ (rounded)}$$

Figure 6.4 shows the material balance. About 17% of the influent leaves the process as metal-contaminated sludge that must be handled according to the regulations for hazardous waste disposal. The cost of disposal will be reduced by thickening the sludge. Doubling the concentration to 4% will reduce the volume by 50%, from 174 m<sup>3</sup> to 87 m<sup>3</sup>. Another doubling, to 8% solids, will halve the volume again to 43.5 m<sup>3</sup>. Reducing the volume to less than 10 m<sup>3</sup> should be possible.

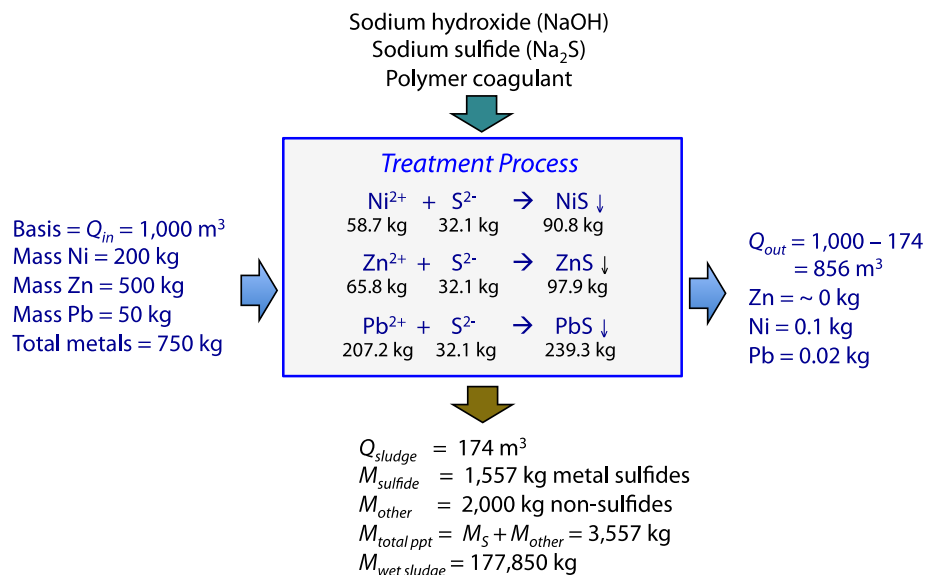


Figure 6.4 Overall mass balance on the metal precipitation process.

## 6.5 Empirical Stoichiometry in Wastewater Treatment

Biological transformations are used in wastewater treatment to remove biodegradable organic compounds. *Biodegradable* means 'able to be consumed or altered by a living organism'. The organisms of primary interest are bacteria. The organic compounds are mainly carbohydrates, fats and proteins, that contain carbon (C), hydrogen (H), oxygen (O), nitrogen (N), phosphorus (P), and traces of other elements.

It is impossible to write precise balanced stoichiometric equations for biological wastewater treatment because the kinds and amounts of the biodegradable organic compounds are not known. The empirical composition of the biodegradable organics in municipal wastewater can be obtained by analyzing for the common elements (C, H, O, N, P, S, etc.) but this is difficult and not useful unless one knows the fraction of the organics that become new bacterial cells.

Common practice is to measure the compositions of wastewater and sludge in 'lumped' or aggregated quantities, such as Chemical Oxygen Demand (COD), total solids and volatile solids. A 'lump' of COD contains many kinds of organic chemicals and we don't know or care what they are. We only need to know that COD can be changed into lumps of something else, like carbon dioxide or bacterial solids.

Unlike a mass of an element (Ca) or chemical compound ( $\text{CaCl}_2$ ), "lumped parameters" cannot be expressed in the traditional chemical units of g-moles or kg-moles. They are measured in mass units (mg/L or mg/kg) and the empirical stoichiometry is in the form of a statement like "1 kg COD  $\rightarrow$  0.65 kg suspended solids".

Most of the substances in wastewater that are measured as COD are biodegradable organic compounds, but COD also includes compounds that are not biodegradable.

This means that a biologically treated effluent may have a relatively large COD. It may happen that 98% of biodegradable organic compounds are removed but only 80% of COD is removed. The portion of the influent COD that is not touched by microbial action remains as COD in the effluent. Efficiency is best measured by the change in COD and not by the final concentration or the percent removal.

Organic solids are more precisely known as volatile solids because they are measured by burning (volatilizing) at 550°C. C, H, O, and N are volatilized when burned. Non-volatile substances remain as ash. Phosphorus is not volatile; it becomes part of the ash residue and is measured as an inert solid. The loss in mass (initial mass – ash residue) is the mass of the volatile solids.

An *aerobic* process (aerobic means that oxygen is required) will yield carbon dioxide and new bacterial cells. The hydrogen is converted to water. Nitrogen becomes ammonia or nitrate. Phosphorus is incorporated into new bacterial cells.

The empirical relations for an aerobic process are

- 1 kg BOD removed → 0.5 kg VSS (bacterial cells)
- 1 kg COD removed → 0.5 kg total suspended solids (TSS) produced
- 1 kg COD removed → 0.35–0.4 kg volatile suspended solids (VSS) produced

An *anaerobic* process (anaerobic means that oxygen is not required) will convert a fraction of the organic carbon to a gas that is typically 60-70% methane ( $\text{CH}_4$ ) and 30-40% carbon dioxide ( $\text{CO}_2$ ). Hydrogen is converted to water ( $\text{H}_2\text{O}$ ). The fate of nitrogen and phosphorus depends on the process.

The empirical relations for an anaerobic process are

- 1 kg Volatile Solids destroyed → 0.7–1.1 m<sup>3</sup> gas produced ( $\text{CH}_4 + \text{CO}_2$ )
- 1 kg Volatile Solids destroyed → 0.55–0.75 m<sup>3</sup>  $\text{CH}_4$  produced (assuming the gas is 70% methane)
- 1 kg COD destroyed → 0.30–0.45 m<sup>3</sup> methane produced

## 6.6 Case Study – Anaerobic Sludge Digestion

Figure 6.5 shows sludge entering an anaerobic digester at a total solids concentration of 4% solids by dry weight; 70% of the solids are organic and 30% are inert. This is typical of municipal sewage sludge. The digested sludge solids are 50% organic and 50% inert.

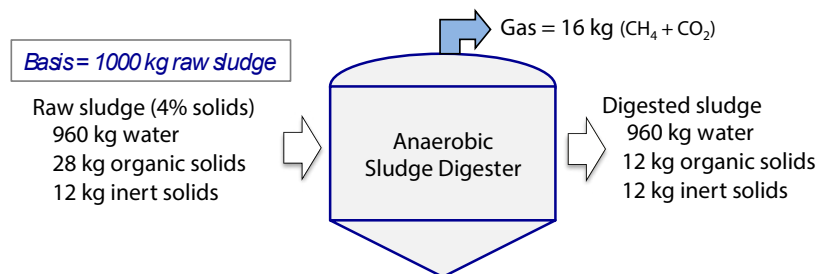


Figure 6.5 Anaerobic sludge digester.

Assume that

- The flow of sludge into and out of the digester is continuous and the volume of sludge in the digester does not change with time.
- The organic solids that do not leave in the digested sludge are converted into gas ( $\text{CH}_4$  and  $\text{CO}_2$ ).
- Water that evaporates from the sludge can be neglected.

The basis is 1000 kg of sludge. The tie components are inert solids (fixed solids) and water. All the inert solids leave in the digested sludge. Water entering with the sludge leaves with the sludge.

The sludge consists of 40 kg solids and 960 kg of water.

$$\left[ \begin{array}{c} \text{water in with} \\ \text{raw sludge} \end{array} \right] = \left[ \begin{array}{c} \text{water out with} \\ \text{digested sludge} \end{array} \right] = 960 \text{ kg}$$

The 40 kg of solids are divided into 28 kg (70%) of volatile solids (organic solids) and 12 kg (30%) of inert solids. The inert solids pass through the digester unchanged. The material balance on inert solids

$$\left[ \begin{array}{c} \text{inert solids in} \\ \text{with raw sludge} \end{array} \right] = \left[ \begin{array}{c} \text{inert solids out with} \\ \text{digested sludge} \end{array} \right] = 12 \text{ kg}$$

The solids in the digested sludge are 50% organic and 50% inert and

$$\left[ \begin{array}{c} \text{organic solids in} \\ \text{digested sludge} \end{array} \right] = \left[ \begin{array}{c} \text{inert solids in} \\ \text{digested sludge} \end{array} \right] = 12 \text{ kg}$$

$$\left[ \begin{array}{c} \text{organic solids} \\ \text{destroyed} \end{array} \right] = \left[ \begin{array}{c} \text{organic solids} \\ \text{in raw sludge} \end{array} \right] - \left[ \begin{array}{c} \text{organic solids out} \\ \text{in digested sludge} \end{array} \right] = 28 \text{ kg} - 12 \text{ kg} = 16 \text{ kg}$$

The 16 kg of gas produced can be burned to heat the digester or drive a gas engine. The composition is 70% methane (CH<sub>4</sub>) and 30% carbon dioxide (CO<sub>2</sub>), by volume percent.

**gaiTeye**  
Challenge the way we run

**EXPERIENCE THE POWER OF FULL ENGAGEMENT...**

**RUN FASTER.  
RUN LONGER..  
RUN EASIER...**

**READ MORE & PRE-ORDER TODAY  
WWW.GAITEYE.COM**



The solids concentration in the digested sludge =  $(100)(24)/(960 + 24) = 2.44\%$ . Digestion changes the physical properties of the solids so the digested sludge can be easily dewatered, while the raw sludge cannot. A thickening process that would double the solids from 2.44% to 4.88% will reduce the sludge volume by half.

## 6.7 Case Study – Aerobic Wastewater Treatment

An activated sludge process is an aerated reactor that converts COD to carbon dioxide and bacterial cells followed by a clarifier to remove the solids (mainly flocculated bacterial cells) from the effluent. The bacterial cells are the ‘activated sludge’. The clarifier also functions to concentrate the solids for recycle to the reactor (return activated sludge = RAS) or for removal for sludge treatment (waste activated sludge = WAS).

The next two sections explain the biological yield coefficient, first how it can be estimated from process operating data and, second, how the mass of biological solids produced in the process is estimated.

### 6.7.1 Biomass Yield Factor in an Activated Sludge Process

The activated sludge process shown in Figure 6.6 has measured values for all the flow rates, total suspended solids (TSS) and biochemical oxygen demand (BOD). These values can be used to calculate the biomass yield factor ( $Y$ ) for the process, in kg TSS/kg BOD removed.

WAS is waste activated sludge, which is intentionally removed from the activated sludge process to balance the new biomass that is produced by the treatment process.

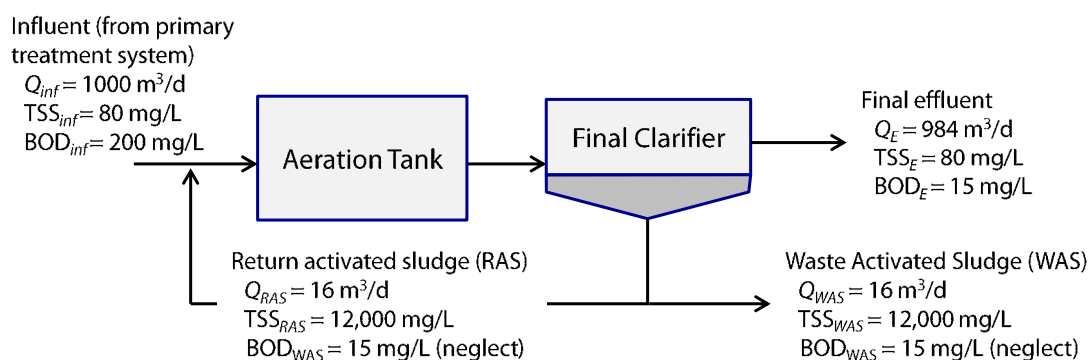


Figure 6.6 Activated sludge process with all inputs and outputs measured.

Overall Material Balance on Flow

Primary influent = Final effluent + Waste Activated Sludge (WAS)

$$Q_{inf} = Q_E + Q_{WAS}$$



### Overall Material Balance on Solids

$$\begin{aligned} & \text{Solids in primary influent} + \text{Solids yield from BOD removal} \\ & = \text{Solids in Final Effluent} + \text{Solids in Waste Activated Sludge} \\ & Q_{inf} \text{BOD}_{inf} + \text{Solids yield from BOD removal} = Q_E \text{BOD}_E + Q_{WAS} \text{BOD}_{WAS} \end{aligned}$$

$$\text{Solids in primary influent} = Q_{inf} \text{BOD}_{inf} = (1,000 \text{ m}^3/\text{d})(0.08 \text{ kg/m}^3 \text{ BOD}) = 80 \text{ kg/d}$$

$$\text{Solids in final effluent} = Q_E \text{BOD}_E = (984 \text{ m}^3/\text{d})(0.015 \text{ kg/m}^3 \text{ TSS}) = 14.8 \text{ kg/d TSS}$$

$$\text{Solids in waste activated sludge} = Q_{WAS} \text{BOD}_{WAS} = (16 \text{ m}^3/\text{d})(12 \text{ kg/m}^3 \text{ TSS}) = 192 \text{ kg/d TSS}$$

$$\text{Total solids out} = 192 \text{ kg/d} + 14.8 \text{ kg/d} = 206.8 \text{ kg/d}$$

$$\begin{aligned} \text{Solids yield from BOD removal} &= \text{Total solids out} - \text{Solids in primary influent} \\ &= 206.8 \text{ kg/d} - 80 \text{ kg/d} = 126.8 \text{ kg/d} \end{aligned}$$

$$\text{BOD removed} = (1,000 \text{ m}^3/\text{d})(0.2 - 0.015 \text{ kg/m}^3) = 185 \text{ kg/d}$$

$$\text{Yield factor} = (126.8 \text{ kg/d TSS produced}) / (185 \text{ kg/d BOD removed}) = 0.68 \text{ kg TSS/kg BOD removed}$$

### 6.7.2 Estimating the Waste Activated Sludge for an Activated Sludge Process

Figure 6.7 is the block diagram for an activated sludge process that will treat 24,000 m<sup>3</sup>/d with a COD = 0.5 kg/m<sup>3</sup> (500 mg/L). This is a daily load of 12,000 kg/d. Ninety percent of the influent COD is removed, so the effluent contains 0.05 kg/m<sup>3</sup> (50 mg/L), or 1,200 kg/d. The effluent contains 0.01 kg/m<sup>3</sup> of total suspended solids, or 10 mg/L TSS.

The empirical stoichiometry is

$$\begin{aligned} 1 \text{ kg COD removed} &\rightarrow 0.5 \text{ kg total suspended solids (TSS) produced} \\ 1 \text{ kg COD removed} &\rightarrow 0.35 - 0.4 \text{ kg volatile suspended solids (VSS) produced} \end{aligned}$$

The bacterial solids in the sludge coming off the bottom of the clarifier have a specific gravity just slightly larger than 1.0 and we assume the density of the waste activated sludge is 1000 kg/m<sup>3</sup>. The total solids concentration is 1% solids by weight, which is 10 kg/m<sup>3</sup> = 10,000 mg/L. The solids are 75% volatile and 25% fixed, or 7,500 mg/L volatile solids and 2,500 mg/L fixed solids. Another assumption is that the dissolved solids are negligible in comparison to the suspended solids (roughly 200 mg/L dissolved and 10,000 mg/L suspended solids).



**Figure 6.7** Block diagram for an activated sludge process.

The basis is 24,000 m<sup>3</sup> of wastewater and 12,000 kg COD.

The overall material balance on COD is:

$$COD_{inf} = COD_{removed} + COD_{eff} + COD_{WAS}$$

$$(24,000 \text{ m}^3)(0.5 \text{ kg}/\text{m}^3) = \text{COD removed} + (24,000 - Q_{WAS})(0.05 \text{ kg}/\text{m}^3) + (Q_{WAS})(0.05 \text{ kg}/\text{m}^3)$$

$$COD_{removed} = (24,000 \text{ m}^3)(0.5 \text{ kg}/\text{m}^3) - (24,000 \text{ m}^3)(0.05 \text{ kg}/\text{m}^3) = 10,800 \text{ kg COD}$$

This e-book  
is made with  
**SetaPDF**



**SETASIGN**

PDF components for PHP developers

[www.setasign.com](http://www.setasign.com)





The term  $Q_{\text{WAS}}$  ( $0.05 \text{ kg/m}^3$ ) is the mass of COD in the liquid that carries the waste activated sludge, assuming it is the same concentration as the effluent COD.

The empirical stoichiometry for the conversion of COD to biomass

0.5 kg TSS produced per 1 kg COD removed

TSS produced =  $(0.5 \text{ kg/kg})(10,800 \text{ kg COD removed}) = 5,400 \text{ kg TSS}$

VSS produced =  $0.75 \text{ TSS produced} = (0.75)(5,400 \text{ kg}) = 4,050 \text{ kg VSS}$

*Waste Activated Sludge Calculation.* The reactor is operated so the mass of total suspended solids and volatile suspended solids is constant. This means that all solids produced are removed, either in the effluent or as waste activated sludge (WAS).

TSS produced = TSS removed as WAS + TSS<sub>eff</sub>

$5,400 \text{ kg} = (10 \text{ kg/m}^3)(Q_{\text{WAS}}) + (0.01 \text{ kg/m}^3)(24,000 \text{ m}^3 - Q_{\text{WAS}})$

$5,400 \text{ kg} = 10 Q_{\text{WAS}} + 240 \text{ kg} - 0.01 Q_{\text{WAS}}$

$9.99 Q_{\text{WAS}} = 5,160$

$Q_{\text{WAS}} = 517 \text{ m}^3$

The waste activated sludge flow (WAS) is about 2% of the influent. The WAS must be further concentrated and stabilized before disposal. This can be done by gravity thickening and anaerobic digestion. The volume can be reduced by 75% by thickening the solids from 1% to 4%. The limit for gravity thickening or dissolved air flotation is 4–6% solids. More thickening requires special equipment and is not often economical. After anaerobic digestion the sludge volume can be reduced by a variety of economical treatments.

A short-cut approximation assumes that effluent suspended solids are negligible in comparison to WAS solids. The relative amounts calculated in this example were 240 kg effluent solids and 5,160 kg WAS solids. This assumption gives an approximate WAS volume of  $540 \text{ m}^3$  instead of  $517 \text{ m}^3$ . Approximations based on reasonable assumptions can be useful first approximations.

## 6.8 Hypothetical Case Study – Cutter Chemicals

This hypothetical case study is about the Cutter Chemicals Company's request for a permit from the Department of Environmental Protection to discharge treated wastewater into the Fox River. The chemistry is simplified and many details are omitted, but it illustrates a realistic problem analysis.

The company has proposed a new chemical manufacturing plant near Barstow on the Fox River. Figure 6.8 is a map of the region indicating several factors that must be assessed.

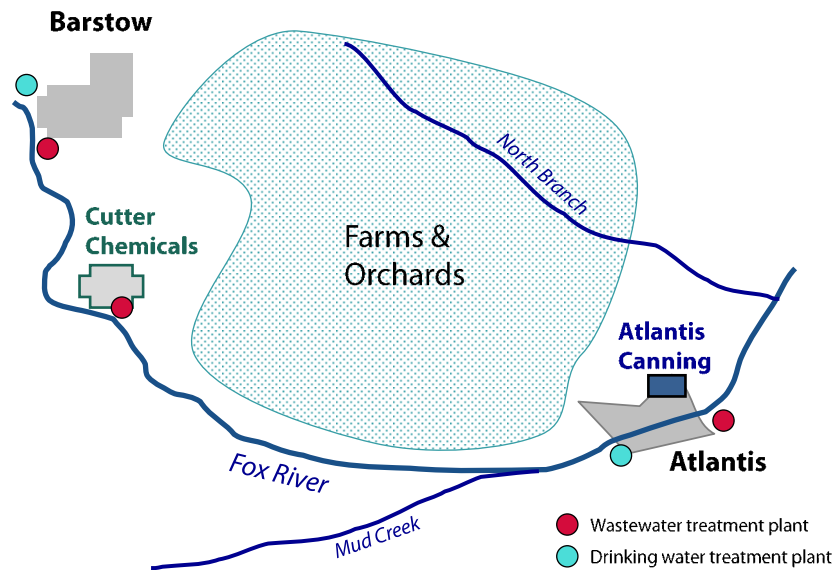


Figure 6.8 Map of the Fox River showing the proposed location of the Cutter Chemicals facility.

**Cutter Chemicals.** We propose to construct a chemical plant on the Fox River, south of the city of Barstow. The output will be 20 T/d of silicone polymer. About 100 new jobs will be created with an annual payroll of \$6,000,000. We need a permit to discharge small amounts of wastewater into the river.

An explicit requirement is that dissolved oxygen in the river shall not fall below 4 mg/L at any time or place. Discharge of grease or other floating materials is not permitted. Chloride concentration shall not exceed 250 mg/L. No toxic chemicals shall be discharged. The treated wastewater effluent BOD and the effluent suspended solids shall not exceed an average of 20 mg/L over any monthly period.

Those requirements are clear and we have no problem with compliance. Our difficulty is with another part of the state statute that uses the non-technical term ‘injurious’. We are not sure how to evaluate that.

The language is: “What is or may become injurious to public health, safety, and welfare; what is or may become injurious to recreational uses; what is or may become injurious to industrial or municipal water use; what is or may become injurious to fish, migratory bird life, or wild animal life shall be prohibited under water pollution control provisions of the State.”

**Environmental Protection Agency (EPA).** We can begin by helping you assemble the technical data that must be submitted in the application for a discharge permit. A public hearing will eventually be called to give all interested parties a chance to testify. These are some areas where there could be injury, which we would avoid by negotiating special conditions in your discharge permit.

We are particularly concerned about the down-river effects of the discharge.

1. The City of Atlantis, 10 miles downstream of Barstow, takes its drinking water from the river, which is an excellent source of municipal water. The calcium content is less than 40 mg/L. Calcium, along with magnesium, causes hardness, so it is obvious why Atlantis is interested in this water quality parameter. They would object to an increase in water hardness.
2. The Atlantic Canning Company cans vegetables during July, August, September, and October and uses water purchased from the Atlantis Municipal Water Utility. While the municipal water supplied is usually of high quality, there are problems during the low summer flow when the water has a slight musty odor. Thus far, this has caused no problem for the canning company, but we must be careful not to aggravate the odor problem. Obviously anything that affected the taste of the water would be objectionable as well.
3. The Fox River is used for recreation, and fish and wildlife are abundant.
4. The fruit and vegetable farms, located north and east of Atlantis, irrigate their crops with river water during the summer growing season. Table 6.1 gives guidelines for irrigation water quality.



www.sylvania.com

We do not reinvent  
the wheel we reinvent  
light.

Fascinating lighting offers an infinite spectrum of possibilities: Innovative technologies and new markets provide both opportunities and challenges. An environment in which your expertise is in high demand. Enjoy the supportive working atmosphere within our global group and benefit from international career paths. Implement sustainable ideas in close cooperation with other specialists and contribute to influencing our future. Come and join us in reinventing light every day.

Light is OSRAM

OSRAM  
SYLVANIA



Water Quality Parameter	Concentration at which problems may appear	Concentration that may reduce yield or require a crop change
Coliform organisms (MPN/100 mL)	1000	(a)
Total dissolved solids (mg/L)	500	1500
Conductivity ( $\mu\text{mhos}/\text{cm}^2$ )	750	2250
Range of pH	7.0–8.5	6.0–9.0
Sodium absorption ratio (SAR)	6.0 (b)	15
Arsenic (mg/L)	1.0	5.0
Boron (mg/L)	0.5	2.0
Chloride (mg/L)	100	350
Sulfate (mg/L)	200	1000
Copper (mg/L)	0.1	1.0

(a) Strict limits on land used to grow fruits and vegetables for human consumption  
 (b) Sodium renders soil impermeable to air and water. A Sodium Adsorption Ratio (SAR) > 20 is serious and requires special management practices such as application of gypsum.

$$SAR = Na^+ / \sqrt{0.5(Ca^{2+} + Mg^{2+})}$$

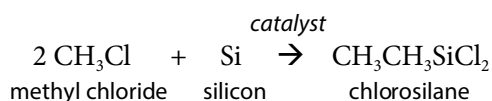
**Table 6.1** Guidelines for irrigation water quality.

Before going farther, help us understand how your manufacturing process, the kinds of wastes it will generate, and their sources in the factory.

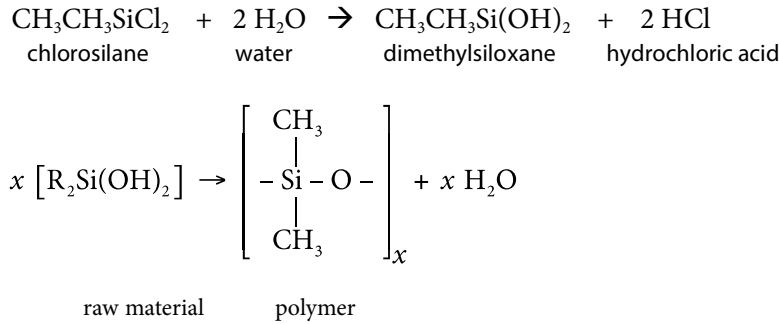
**Cutter.** We manufacture synthetic polymers that are composed of the elements silicon, carbon, hydrogen, and oxygen. They may take the form of oily liquids, resins, or rubbery solids (elastomers), depending on their chemical composition and the average size of the molecule. The product is able to withstand comparatively high temperatures without decomposing and it is chemically inert to dilute acids and most reagents, except strong alkalis and hydrofluoric acid, both of which can destroy their basic structure.

The starting material is silica in the form of sand or quartzite ( $\text{SiO}_2$ ). Silicon is vigorously attacked by gaseous chlorine, and hydrofluoric acid, nitric acid, or aqueous ammonia at ordinary temperatures. It stands just below carbon in the periodic table and is expected by simple analogy to form chain and ring compounds with hydrogen and halides (Cl, F), as well as to form complex hydrogen-oxygen compounds.

The process starts by reacting methyl chloride ( $\text{CH}_3\text{Cl}$ ) with silicon (Si) to make a simple chlorosilane compound. A catalyst is required.



Then water is added to replace the chloride with hydroxide. Sometimes this is done in a solvent. This yields dimethylsiloxane, a silicone resin that will condense to form a polymer. The process can be adjusted to manufacture polymers with different desirable properties.



The hydrochloric acid is a waste product. Each mole of dimethylsiloxane produced results in 2 moles of hydrochloric acid, or slightly less than 1 kg of HCl per kg of product resin.

About 250 m<sup>3</sup>/d of well water will be pumped into the factory and 230 m<sup>3</sup> of this will be discharged as wastewater.

The estimated wastewater quantities are given in Table 6.2. Table 6.3 gives the estimated pollutant concentrations of the waste streams. These waste streams leave the plant in separate drains and can be treated separately. Figure 6.9 shows the water flow through the proposed process.

Wastewater Source	Basis Estimate	for Volumetric Flow (m <sup>3</sup> /d)
Domestic wastewater	100 employees @ 200 L/d	20 m <sup>3</sup> /d
Process water	3 m <sup>3</sup> /T product	60 m <sup>3</sup> /d
Quench water	6 m <sup>3</sup> /T product	120 m <sup>3</sup> /d
Cooling water blowdown		30 m <sup>3</sup> /d
Total wastewater produced		230 m <sup>3</sup> /d

Table 6.2 Estimated wastewater flows.

Stream	Flow (m <sup>3</sup> /d)	Temp. (°C)	pH	BOD <sub>5</sub> (mg/L)	Chloride (mg/L)	Calcium (mg/L)	SS (mg/L)
Well water supply	250	15	7.0	0	120	50	0
Domestic sewage (1)	20	20	7.0	300	150	50	300
Cooling water blowdown	30	20	7.0	5	600	300	10
Process waste	60	15	3.0	5	130	50	0
Quench water	120	20	1.5	120	150,000	50	(2)
Quench water, neutralized (3)			7–8		150,000	84,625	
Combined wastewater	230	20	7.0 (3)	10 (4)	78,300	83	10 (4)

- (1) Bacterial count = 100,000 coliforms per 100 ml.  
 (2) Quench converts some silicone to silicon dioxide, SiO<sub>2</sub> (sand).  
 (3) After neutralization  
 (4) After treatment

Table 6.3 Water use and discharge by silicone plant.



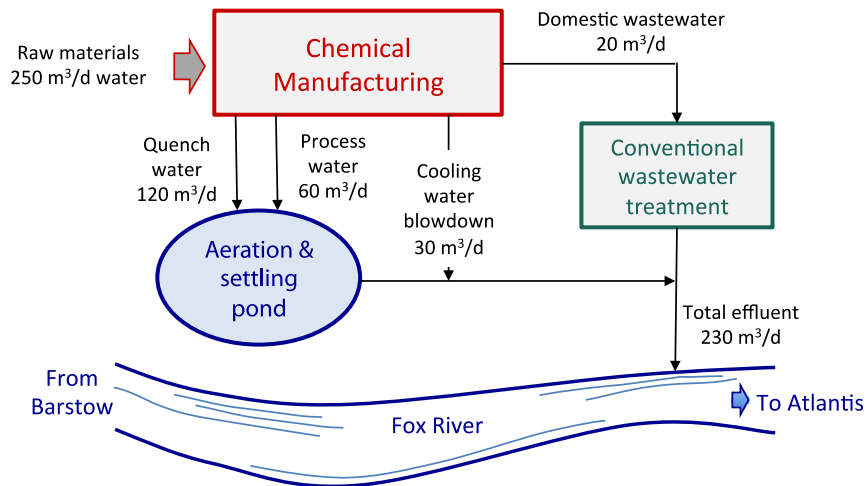


Figure 6.9 Water flow through the silicone rubber process.

The domestic wastewater will be treated using conventional methods. Aeration and settling will solve the BOD, suspended solids, and bacterial problems. The cooling tower blowdown carries only minerals; none are toxic. The quench water and process water will be neutralized and treated further in an aerated pond with a setting basin.

The estimated situation for the quench water is shown in Figure 6.10.



Discover the truth at [www.deloitte.ca/careers](http://www.deloitte.ca/careers)

**Deloitte.**

© Deloitte & Touche LLP and affiliated entities.



Click on the ad to read more

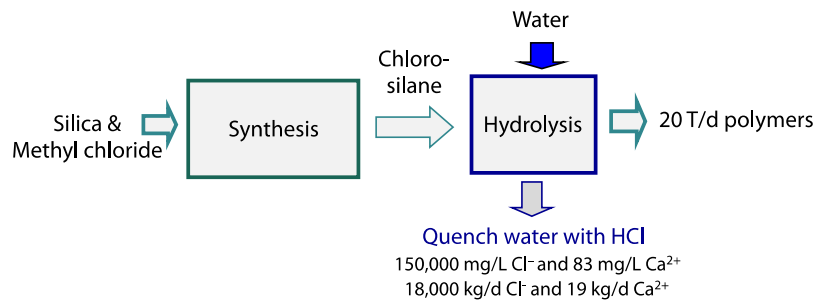


Figure 6.10 Proposed Silicone Synthesis Process with Wastewater Neutralization.

**EPA.** The acidic process and quench water cannot be discharged directly into the river. They will need to be neutralized and discharged into an aerated lagoon with a settling pond. The pond must be constructed to avoid groundwater contamination or seepage directly to the river. The clear water from this pond may be discharged to the river.

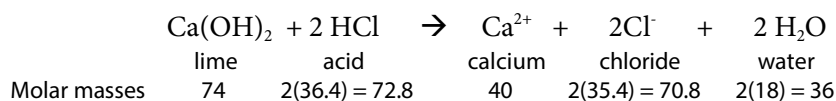
The 150,000 mg/L chloride content of the quench water is a problem. It raises the chloride concentration of the combined effluent to 78,000 mg/L.

The cooling water blowdown contains mineral salts and can be discharged directly to the river, if it is not contaminated with biocides, corrosion inhibitors, copper, or phosphates.

**Cutter.** The acidity of the quench and process water streams is caused by hydrochloric acid (HCl) which is formed in the hydrolysis reaction during the manufacturing. All we need to do is inject lime (Ca(OH)<sub>2</sub>) into these waste streams prior to aeration to bring the pH toward the 7 to 8 range.

**Environmental Protection Agency.** Neutralization does not change the chloride content, but it does increase the calcium, because lime is calcium hydroxide. The calcium and the chloride will be soluble in the river.

The balanced stoichiometric equation for the neutralization is

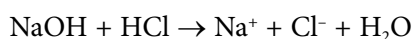


This shows that approximately 74 kg of lime is needed to neutralize 72.8 kg of HCl, or about 1 kg per kg. Each kg of acid neutralized results in 40/72.8 = 0.55 kg of calcium and about 1 kg of chloride (70.8/72.8 = 0.97 kg/kg). This is 1.55 kg of soluble minerals, Ca and Cl, put into the river for each kg of acid neutralized.

Hardness is expressed as calcium carbonate ( $\text{CaCO}_3$ ) and 40 g of calcium (Ca) is equivalent to 100 g of  $\text{CaCO}_3$ . Neutralization of 1 kg of HCl creates 1.38 kg of hardness.

Atlantis and the Atlantis Canning Company will argue that the higher levels of hardness and chloride are *injurious*.

The neutralization could be done with sodium hydroxide, NaOH, instead of calcium hydroxide but this would only put sodium into the river instead of calcium.



This does not increase the water hardness, but each 1 kg of NaOH adds almost 0.6 kg of  $\text{Na}^+$  and sodium is not good in irrigation water, so changing chemicals does not eliminate our concern.

**Cutter Chemicals.** The total effluent is only 230  $\text{m}^3/\text{d}$  and the river is large enough to provide substantial dilution. The concentrations in the river need to be calculated.

The theoretical stoichiometry for producing 20,000 kg/d dimethylsiloxane and 15,834 kg/d HCl predicts a chloride concentration in the quench water of 132,000 mg/L. The actual stoichiometry will be less efficient so we have based our analysis on a chloride concentration of 150,000 mg/L in 120  $\text{m}^3/\text{d}$  of quench water, which is 18,000 kg/d Cl.

We will use this higher value and assume that all the chloride comes from the production of HCl.

The 18,000 kg/d Cl contained in 18,508 kg HCl is

$$(18,508 \text{ kg HCl}) / (36.45 \text{ kg/kg-mol}) = 507.8 \text{ kg-mol HCl}$$

To neutralize 1 mole of HCl requires 0.5 moles of lime, or 253.9 kg-mol  $\text{Ca}(\text{OH})_2$ . The mass of lime is

$$(253.9 \text{ kg-mol}) (74.1 \text{ kg/kg-mole}) = 18,812 \text{ kg/d Ca}(\text{OH})_2$$

The mass of calcium is

$$(18,812 \text{ kg/d}) \left( \frac{40 \text{ kg Ca}^{2+}}{74.1 \text{ Ca}(\text{OH})_2} \right) = 10,155 \text{ kg Ca}^{2+}$$

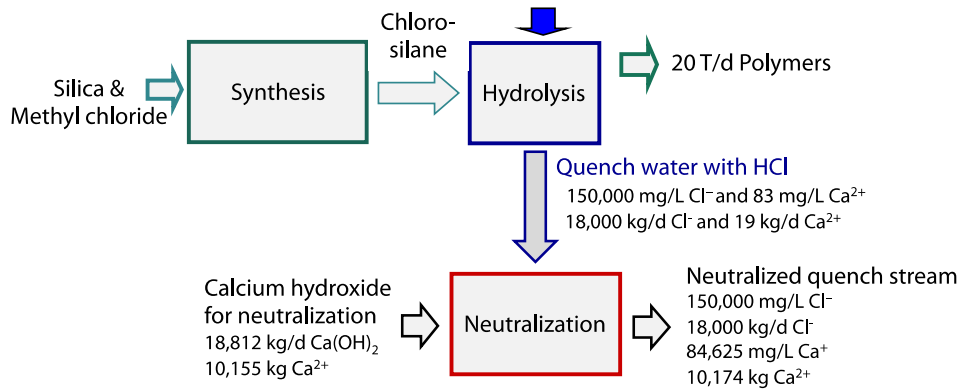
The calcium causes water hardness: 40 kg  $\text{Ca}^{2+} = 100 \text{ kg hardness expressed as CaCO}_3$ .

$$(10,155 \text{ Ca}^{2+}) \left( \frac{100 \text{ kg/mol CaCO}_3}{40 \text{ kg/kg mol Ca}^{2+}} \right) = 25,387 \text{ kg CaCO}_3 \text{ (Calcium hardness)}$$

The concentration of calcium in the neutralized quench water is

$$\frac{10,155 \text{ kg/d Ca}^{2+}}{120 \text{ m}^3/\text{d}} = 84,625 \text{ kg/m}^3 \text{ Ca}^{2+} = 84,625 \text{ mg/L Ca}^{2+}$$

Figure 6.11 shows the material balance for the neutralization process.



**Figure 6.11** Material flow in the quench water neutralization process.

SIMPLY CLEVER

ŠKODA



We will turn your CV into  
an opportunity of a lifetime



Do you like cars? Would you like to be a part of a successful brand?  
We will appreciate and reward both your enthusiasm and talent.  
Send us your CV. You will be surprised where it can take you.

Send us your CV on  
[www.employerforlife.com](http://www.employerforlife.com)



Click on the ad to read more

Table 6.4 gives representative historical river flows measured just below Cutter's proposed discharge. The lowest river flow occurs in September; the average flow for this month is 2.69 m<sup>3</sup>/s. The lowest recorded river flow is 1.30 m<sup>3</sup>/s. The chloride and calcium concentrations observed at the record low flow condition were 125 mg/L and 75 mg/L, respectively.

At the lowest flow ever recorded the effluent would be diluted by 1.30 m<sup>3</sup>/s = 112,320 m<sup>3</sup>/d with a chloride concentration of 125 mg/L. The dilution factor is 1000 to 1.

Calculate the chloride in the river below the discharge.

$$\begin{aligned} (\text{River Cl, mg/L})(112,550 \text{ m}^3/\text{d}) &= (78,300 \text{ mg/L})(230 \text{ m}^3/\text{d}) + (125 \text{ mg/L})(112,320 \text{ m}^3/\text{d}) \\ \text{River Cl} &= 285 \text{ mg/L} \end{aligned}$$

The estimated chloride concentration for each month, based on the average river flow, is given in Table 6.4. The concentrations are increased greatly by the industrial waste load and they reach worrisome levels, even at average flow conditions. At low flow the concentrations might be two or three times larger the estimates shown.

Month	J	F	M	A	M	J	J	A	S	O	N	D	Lowest Record
Ave. flow (m <sup>3</sup> /s)	6.94	10.45	18.78	16.03	9.80	5.58	4.33	3.12	2.69	4.62	6.51	6.60	1.3
<b>Concentrations with No Industrial Waste</b>													
Chloride (mg/L)	26	18	10	12	18	32	42	58	66	40	28	26	125
Calcium (mg/L)	14	10	6	6	10	18	24	26	38	22	16	14	75
<b>Concentrations with Industrial Wastewater, but without Neutralization</b>													
River Cl (mg/L)	56	38	21	25	39	69	90	125	143	85	60	58	285
River Ca (mg/L)	14	10	6	6	10	18	24	26	38	22	16	14	75
<b>Concentrations with Industrial Wastewater, after Neutralization</b>													
River Cl (mg/L)	54	36	20	24	38	66	86	119	137	81	57	55	272
River Calcium (mg/L)	31	21	12	13	22	39	51	64	82	47	34	32	165

**Table 6.4** Monthly discharge of the Fox River near Atlantis, based on 50 years of record.

**EPA.** Discharging this neutralized waste acid will definitely degrade the water quality. We will not grant a discharge permit for the proposed levels of chloride and the anticipated levels of calcium after neutralization.

The Atlantis Canning Company and Atlantis electric power utility use river water in their cooling system and boilers. The existing concentrations of 40–60 mg/L chloride and 20–40 mg/L calcium are excellent. The water can be recycled through the cooling towers and the boilers many times before the chloride levels increase to a problem level. The same is true for calcium because at the low natural levels there are no major scaling problems.

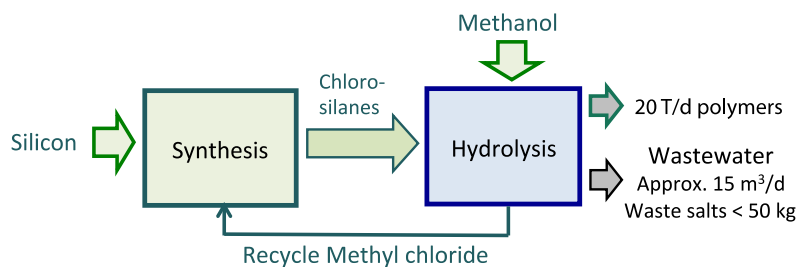
**Cutter.** This is a question of economics as well as technical feasibility. Both can be studied. We will redesign to reduce the waste production. We do not want to face the cost and embarrassment of building the process only to discover that it is a polluter and has to be extensively modified.

**EPA.** There may be other wastewater problems. We may ask you to remove at least 90 percent of the phosphorus from the sanitary sewage. Also, you will need to justify your assertion that the cooling water can be discharged directly. We also advise that you check on whether any material that enters the process contains a regulated toxic substance.

You will need similar evaluations in support of permits for gaseous emissions, solids waste disposal, and stormwater management.

In short, it is essential to assess the hazard potential of every step of the manufacturing process, including raw materials receiving and product shipping, to insure no problem has been overlooked.

**Cutter.** (A short time later). We have discovered a much better way of synthesizing silicone that eliminates most of the problems with chloride and calcium in the wastewater. Instead of adding water to hydrolyze the chlorosilanes, we can use methanol (methyl alcohol). The chlorosilane and methanol react to produce methyl chloride and silicone. The methyl chloride is recycled. This reaction eliminates the acid formation and the need for neutralization. The amount of wastewater is reduced by about 75 percent and the amount of salts going to the river is reduced by almost 99 percent. Figure 6.12 shows the proposed “river-friendly” silicone synthesis process. The wastewater output is approximately 0.75 T per 1 T of silicone produced, with less and 50 kg waste salts.



**Figure 6.12** Flow diagram for the revised process.

**Final Comments.** The material balance is an essential tool for assessing the potential impacts of industrial and domestic effluents on the environment. In this case the original effluent was too acidic. The proposed lime treatment would solve that problem, but it would do nothing to reduce the chloride emissions, and the calcium in the lime was itself a new pollutant. The high levels of calcium and chloride would degrade the river and disadvantage users of the river water and, as a result, were pollutants even though they were not toxic.

## 6.9 Conclusion

The balanced chemical equation that shows reactants and products, in their proper proportions, is a statement of a material balance. The mass of atoms in the reactants (inputs) must also appear as products (outputs). The process material balance with chemical transformations is how we keep track of the material as it moves through the system.

Empirical stoichiometry is often used in pollution control work. This stoichiometry is expressed as 'lumped' measurements of substances that cannot be expressed in the usual chemical units of moles. Total solids, suspended solids, BOD and COD are such substances. They are measured in mass units and the empirical stoichiometry in statements such as "1 kg COD  $\rightarrow$  0.65 kg suspended solids".

This introduction to the material balance showed how to work out a great deal of information about a process, but it did not determine the size of the processes. The volume and detention time of the reactors were not calculated. The implicit assumption was that the detention time, whatever its duration, was sufficient for the chemical transformations to run to completion. That is, all reactants became part of the products as shown in the balanced stoichiometric equation. The calculation of reaction rates and detention times will be explained in another book about chemical and biological transformations.

I joined MITAS because  
I wanted **real responsibility**

The Graduate Programme  
for Engineers and Geoscientists  
[www.discovermitas.com](http://www.discovermitas.com)



**Month 16**  
I was a construction supervisor in the North Sea advising and helping foremen solve problems

Real work  
International opportunities  
Three work placements





# 7 The Unsteady-State Material Balance

## 7.1 The Design Problem

Unsteady-state problems have changing inputs and/or outputs and/or changing operating conditions. Flows and concentrations may change, reactor temperatures may change, and so on.

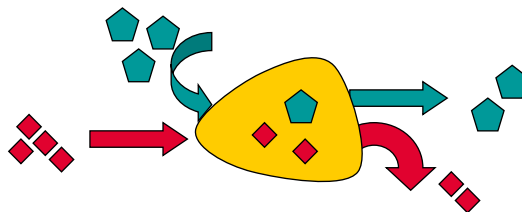
These issues can be handled during preliminary design by making a steady-state analysis for minimum, maximum, and average conditions. The later stages of detailed design may require more study of the process dynamics.

## 7.2 The Unsteady-State Material Balance

The unsteady-state material balance, shown in Figure 7.1, applied over a specified time interval is

$$[\text{total mass in}] - [\text{total mass out}] = \left[ \begin{array}{l} \text{accumulation of} \\ \text{mass in theregion} \end{array} \right]$$

This balance is maintained even when material species are being created or destroyed within the region.



**Figure 7.1** Accumulation of material within the region makes the process unsteady-state.

## 7.3 Unsteady-State Storage Systems

Some processes and operations are unsteady-state because material is being intentionally stored or discharged.

- A batch drying operation retains solids while water or solvent is lost by evaporation. The rate of evaporation decreases as the solids concentration increases, so this is an unsteady-state process.
- Pumping stations have a small reservoir (wet well) from which water is drawn into the pumps. The rate of inflow is variable so the volume of water in the wet well varies. If the reservoir is large enough the pump may be able to operate continuously at a uniform rate, which increases the efficiency. If the wet well is relatively small, pumps will operate intermittently, being switched off when the wet well is drawn down and turned on when the wet well is full.

- A storm water detention pond collects rainfall runoff and snowmelt at certain times and the accumulated volume is discharged in a pattern that controls sediment loss and avoids flooding.
- A run-of-river reservoir for flood control or drinking water supply has the same behavior. The reservoir volume, depth and surface area will change throughout the year as inflows fluctuate with rainfall and snow melt. Outflows may be controlled by hydroelectric turbine operations or water demand.
- Influent to wastewater treatment processes that are highly variable in pH or pollutant loading can be smoothed in mixed tanks of constant or variable volume. This can be economical and beneficial.



The advertisement features a background image of a man in a green jacket looking out over a city street. In the top left corner is the IE Business School logo. In the top right corner, a badge reads '#1 EUROPEAN BUSINESS SCHOOL FINANCIAL TIMES 2013'. A white speech bubble on the right contains the hashtag '#gobeyond'. The main text reads 'MASTER IN MANAGEMENT' followed by a paragraph: 'Because achieving your dreams is your greatest challenge. IE Business School's Master in Management taught in English, Spanish or bilingually, trains young high performance professionals at the beginning of their career through an innovative and stimulating program that will help them reach their full potential.' Below this is a bulleted list of three points: 'Choose your area of specialization.', 'Customize your master through the different options offered.', and 'Global Immersion Weeks in locations such as London, Silicon Valley or Shanghai.' At the bottom, it says 'Because you change, we change with you.' and provides contact information: 'www.ie.edu/master-management' and 'mim.admissions@ie.edu' along with social media icons for Facebook, Twitter, LinkedIn, YouTube, and Instagram.

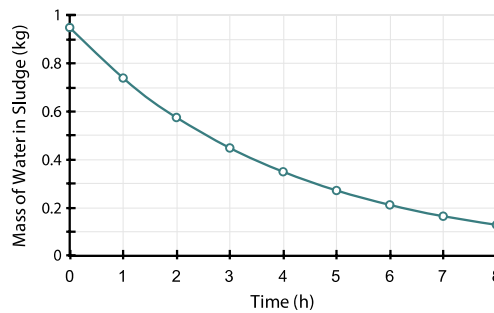


**Example 7.1 SLUDGE DRYING**

A 1 kg portion of sludge was dried in a shallow pans exposed to outdoor summer conditions. At the beginning of the experiment each pan contained 0.05 kg solids and 0.95 kg water. From time to time, a pan of drying sludge was weighed to obtain the results in Table 7.1, which shows the unsteady-state material balance for the sludge, solids, and water in the drying pans at one-hour intervals for 8 hours. Figure 7.2 shows the mass of water in the pan and the rate of evaporation. The rate of evaporation decreases over time because the water cannot migrate to the sludge surface as easily when the solids are more concentrated.

Time (hour)	0	1	2	3	4	5	6	7	8
Sludge mass (kg)	1.00	0.79	0.63	0.50	0.40	0.32	0.26	0.22	0.18
Solids mass (kg)	0.05	0.05	0.05	0.05	0.05	0.05	0.05	0.05	0.05
Solids conc. (%)	5.00	6.33	7.98	10.0	12.5	15.5	19.1	23.2	28.0
Water mass (kg)	0.95	0.74	0.58	0.45	0.35	0.27	0.21	0.17	0.13
Water Evap. (kg)	0.00	0.21	0.16	0.13	0.10	0.08	0.06	0.05	0.04

**Table 7.1** Material balance for sludge drying



**Figure 7.2** Mass of water remaining in the drying sludge and the rate of evaporation.

**Example 7.2 STORMWATER DETENTION POND**

A 25 hectare (ha) development will have a one hectare stormwater collection pond with a volume of 20,000 m<sup>3</sup>. (1 ha = 10,000 m<sup>2</sup> = 2.47 acres). There is no stream to feed the pond. The soil is sandy clay loam with an infiltration rate of  $I = 0.05$  m/day. The site is 75% impervious surfaces (roads, roofs, etc.). The runoff coefficient is 0.64, meaning that 64% of the precipitation onto the land will runoff, while 36% will infiltrate, evaporate, or be stored in depressions. Will the site support the proposed retention pond?

The change in volume of water in the detention pond is

$$\Delta V = \text{Runoff} + \text{Direct Precipitation} - \text{Evaporation} - \text{Infiltration}$$

*Direct Precipitation* falls directly onto the 1 ha surface of the pond. *Runoff* is calculated from precipitation that falls on the 24 ha land area. All quantities are seasonal except infiltration rate, which for convenience is assumed constant over the year.

The quantities in the material balance are calculated for January, using the values in Table 7.2.

$$\text{Runoff} = 0.64 (\text{Land Area})(\text{Rainfall}) = \frac{0.64(240,000 \text{ m}^2)(10.97 \text{ cm})}{100 \text{ cm/m}} = 16,850 \text{ m}^3 \text{ for January}$$

$$\text{Direct Precipitation} = (\text{Pond Area})(\text{Rainfall}) = \frac{(10,000 \text{ m}^2)(10.97 \text{ cm})}{100 \text{ cm/m}} = 1,097 \text{ m}^3 \text{ for January}$$

$$\text{Evaporation} = (\text{Pond Area})(\text{Evaporation Rate}) = \frac{(10,000 \text{ m}^2)(1.39 \text{ cm})}{100 \text{ cm/m}} = 139 \text{ m}^3 \text{ for January}$$

$$\text{Infiltration} = (\text{Pond Area})(\text{Infiltration Rate}) = \frac{(10,000 \text{ m}^2)(0.05 \text{ m/d})(31 \text{ d})}{100 \text{ cm/m}} = 15,500 \text{ m}^3 \text{ for January}$$

The proposed storage pond has a maximum volume of 20,000 m<sup>3</sup> so there are months when water can be stored in the pond and months when it overflows. The storage is calculated assuming a pond volume of 14,635 m<sup>3</sup> at the beginning of January. A pond volume of almost 29,000 m<sup>3</sup> would be required if no overflow is permitted.

	<b>Rainfall (cm)</b>	<b>Evap. (cm)</b>	<b>Runoff (m<sup>3</sup>)</b>	<b>Precip. (m<sup>3</sup>)</b>	<b>Evap. (m<sup>3</sup>)</b>	<b>Infil. (m<sup>3</sup>)</b>	<b>ΔV (m<sup>3</sup>)</b>	<b>Storage (m<sup>3</sup>)</b>
Jan	10.97	1.39	16,850	1,097	139	15,500	2,308	16,943
Feb	10.82	1.82	16,620	1,082	182	14,000	3,519	20,000
Mar	11.02	3.46	16,927	1,102	346	15,500	2,183	20,000
Apr	10.19	5.09	15,652	1,019	509	15,000	1,162	20,000
May	11.46	6.29	17,603	1,146	629	15,500	2,620	20,000
Jun	9.68	6.29	14,868	968	629	15,000	208	20,000
Jul	12.9	6.34	19,814	1,290	634	15,500	4,971	20,000
Aug	8.31	5.95	12,764	831	595	15,500	-2,500	17,500
Sep	8.23	4.70	12,641	823	470	15,000	-2,006	15,494
Oct	6.38	3.22	9,800	638	322	15,500	-5,384	10,110
Nov	10.19	1.97	15,652	1,019	197	15,000	1,474	11,584
Dec	11.43	1.49	17,556	1,143	149	15,500	3,051	14,635

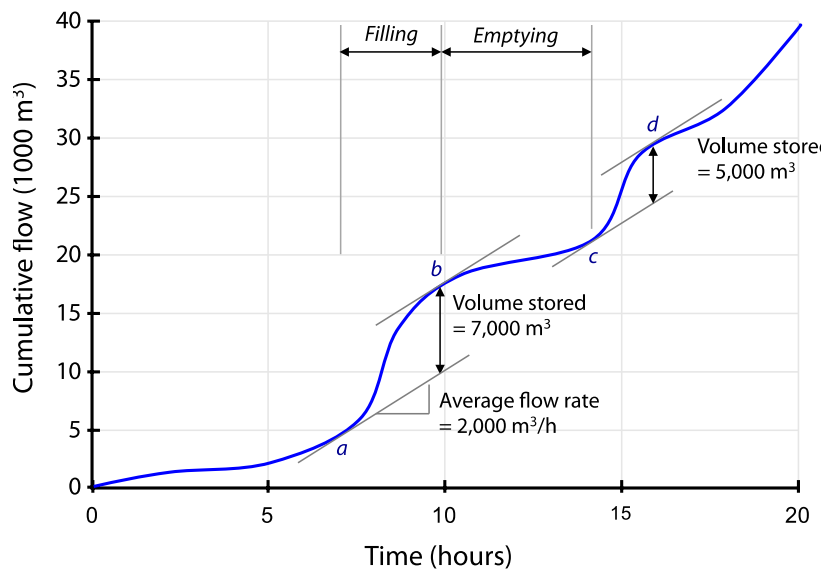
**Table 7.2** Water balance for a 1 hectare stormwater detention pond serving a development of 25 ha.

**Example 7.3 PUMPING STATION WET WELL**

Pumps draw their input from a reservoir (wet-well) that always contains a minimum depth of water so the pump will not run dry. The flow rate into the reservoir is variable so the reservoir inventory increases and decreases. The reservoir is an unsteady-state process and the material balance must account for that.

Figure 7.3 is a cumulative inflow diagram for a wet well that will equalize flow over short time periods. The goal is to pump from the reservoir at the average rate of inflow, which is  $40,000 \text{ m}^3/20 \text{ h} = 2,000 \text{ m}^3/\text{h}$  over the 20-hour period. The graph is a graphical solution for the amount of water that must be stored.

Lines with a slope of  $2000 \text{ m}^3/\text{h}$  have been drawn tangent to the cumulative inflow curve to identify the times when the rate of inflow is equal to the desired average rate of outflow. Point *a* is such a point. From about hours 7–10 hours the rate of inflow exceeds the rate of outflow and the reservoir is filling (the pumps are shut off). At point *b* inflow and outflow rates are again equal, the rate of inflow decreases, and the reservoir volume starts to decrease (the pumps are turned on). At point *c* there is another reversal in the fill-empty cycle. The volume of water that must be stored between points *a* and *b* (hours 7–10) is  $7,000 \text{ m}^3$ ; the volume of water that must be stored between points *c* and *d* is  $5,000 \text{ m}^3$ .



**Figure 7.3** Cumulative inflow diagram for a graphical solution for flow equalization. The average rate of inflow over the 20-hour interval is  $40,000 \text{ m}^3/20 \text{ h} = 2,000 \text{ m}^3/\text{h}$ .

For a wastewater pumping station the cumulative inflow curves would be constructed for a series of days that represent the average and the extreme conditions. Storage is beneficial because pumping efficiency is higher when the flow is more constant (see chapter 14). Flow equalization of the influent to a wastewater treatment plant is rare because the required storage volume is large and the benefits are not.

This cumulative flow analysis is most useful for inflows that have a continuous flow with a fairly regular seasonal or diurnal pattern. The cumulative curve is not so convenient for batch discharges, especially if they arrive randomly.

## 7.4 The Unsteady-State Material Balance – Batch Smoothing

Many industries produce product and waste in batches. Tanning, brewing, and pharmaceuticals are examples. Batches that are variable in volume and strength can create problems in wastewater treatment processes. Depending on the magnitude of the variation and the downstream processing, blending may be helpful to smooth the flow, the concentration and the mass load, or the flow and the mass load.

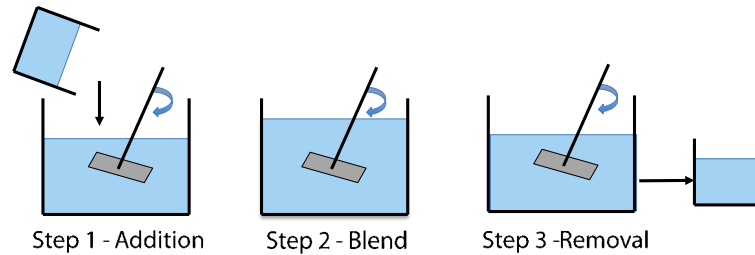


Figure 7.4 Three-steps for batch blending.

*Batch smoothing* and blending is done in three steps, shown in Figure 7.4. An incoming batch is dumped into a blender and mixed with the contents. Mixing makes the contents homogeneous and keeps particles from settling out. Then a batch is withdrawn. A material balance is made for each blending sequence.

**no.1**  
nine years  
in a row

Syden  
Stockholm

## STUDY AT A TOP RANKED INTERNATIONAL BUSINESS SCHOOL

Reach your full potential at the Stockholm School of Economics, in one of the most innovative cities in the world. The School is ranked by the Financial Times as the number one business school in the Nordic and Baltic countries.

Visit us at [www.hhs.se](http://www.hhs.se)

## 7.5 Smoothing the Flow Rate

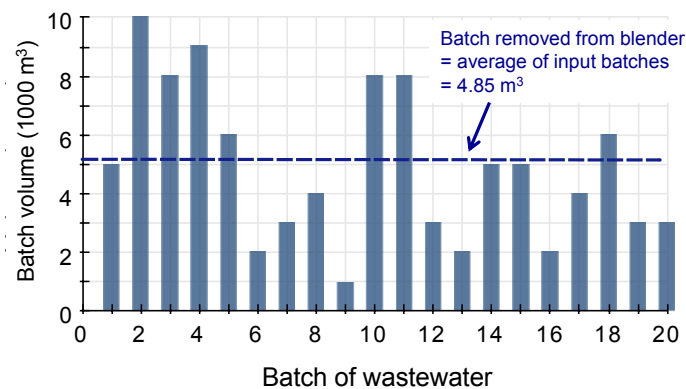
Batch dumps of wastewater vary randomly in volume and this creates an unacceptable condition in the receiving wastewater treatment process. The flows need to be smoothed or equalized. The problem is to determine the storage volume of the flow equalization tank. The solution is found by making a material balance for each batch.

Figure 7.5 shows 20 random batches of wastewater that have volumes ranging from 1,000 m<sup>3</sup> to 10,000 m<sup>3</sup>. The average volume of the 20 batches is 4,850 m<sup>3</sup>. Each arriving batch will be put into a mixed tank. Before the next batch arrives, 4,850 m<sup>3</sup> (the average batch size) will be withdrawn. The volume of liquid in the tank will increase or decrease after each fill-draw cycle.

The general material balance equation is

$$V_t = V_{t-1} + B_t - 4,850 \text{ m}^3$$

where  $V_t$  is the volume stored in the tank and  $B_t$  is the volume of an incoming batch. The subscripts indicate the sequence over time.



**Figure 7.5** Pattern of batch dumps from an industrial process. The average batch size is 4,850 m<sup>3</sup>.

Begin by assuming an initial volume of liquid in the blender, say  $V_0 = 5,000 \text{ m}^3$ . The material balances for the first three batches are

$$V_1 = V_0 + B_1 - 4,850 \text{ m}^3 = 5,000 + 5,000 - 4,850 = 5,150 \text{ m}^3$$

$$V_2 = V_1 + B_2 - 4,850 \text{ m}^3 = 5,150 + 10,000 - 4,850 = 10,300 \text{ m}^3$$

$$V_3 = V_2 + B_3 - 4,850 \text{ m}^3 = 10,300 + 8,000 - 4,850 = 13,450 \text{ m}^3$$



The results of the 20 step-wise calculations are in Table 7.3. The maximum volume in the blender is 18,750 m<sup>3</sup> and the minimum is 5,050 m<sup>3</sup>, for this load pattern and an initial volume of 5,000 m<sup>3</sup>. The maximum volume change is  $\Delta V = 18,730 - 5,000 = 13,750$  m<sup>3</sup>. Based on this admittedly short record of batch dumps, a reasonable volume for the tank would be 20,000 m<sup>3</sup> to prevent overflow and to be sure the tank is never pumped dry.

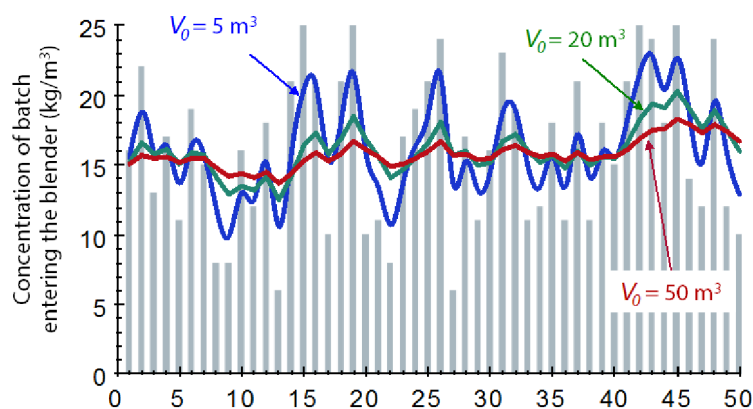
Batch	1	2	3	4	5	6	7	8	9	10
Batch volume (1,000 m <sup>3</sup> )	5	10	8	9	6	2	3	4	1	8
Batch concentration (kg/m <sup>3</sup> )	3	4	7	8	5	5	5	8	2	5
Vol. stored (1,000 m <sup>3</sup> )	5.15	10.30	13.45	17.60	18.75	15.90	14.05	13.20	9.35	12.50
Batch	11	12	13	14	15	16	17	18	19	20
Batch volume (1,000 m <sup>3</sup> )	8	3	2	5	5	2	4	6	3	3
Batch concentration (kg/m <sup>3</sup> )	5	2	3	2	8	3	8	4	4	2
Vol. stored (1,000 m <sup>3</sup> )	15.65	13.80	10.95	11.10	11.25	8.40	7.55	8.70	6.85	5.00

**Table 7.3** Calculation of the volume stored in a blender tank for a series of 20 dumped batches of wastewater.

## 7.6 Smoothing Concentrations

Figure 7.6 shows the results of smoothing the concentration of 50 random batches of wastewater, each of volume 5 m<sup>3</sup>, in blenders with initial volumes of 5 m<sup>3</sup>, 20 m<sup>3</sup> and 50 m<sup>3</sup>. The initial concentration in the blender is assumed at 15 kg/m<sup>3</sup>, giving initial stored inventories of 75 kg, 300 kg, and 750 kg. The larger blender volumes do more smoothing, but  $V_0 = 20$  m<sup>3</sup> is almost efficient as  $V_0 = 50$  m<sup>3</sup>.

Table 7.4 shows some calculations for an initial volume of 5 m<sup>3</sup>. The operation is to mix one batch into the blender until the contents are homogeneous and then to withdraw 5 m<sup>3</sup>. The initial volume of 5 m<sup>3</sup> increases to 10 m<sup>3</sup> and then goes back to 5 m<sup>3</sup>.



**Figure 7.6** Smoothed concentrations of batch dumps using blending tanks with initial volumes of 5 m<sup>3</sup>, 20 m<sup>3</sup> and 50 m<sup>3</sup>. The volume of each entering batch is 5 m<sup>3</sup> and 5 m<sup>3</sup> is removed at the end of each mixing cycle.

Batch	Conc. of batch (kg/m <sup>3</sup> )	Mass added (kg)	Mass in blender (kg)	Mass removed (kg)	Mass at cycle end (kg)	Concentration (kg/m <sup>3</sup> )
		Starting values =	75	--	--	15
1	16	80	155.0	77.5	77.5	15.5
2	22	110	187.5	93.8	93.8	18.8
3	13	65	158.8	79.4	79.4	15.9
4	17	85	164.4	82.2	82.2	16.4
5	11	55	137.2	68.6	68.6	13.7
...	...	...	...	...	...	...
49	12	60	157.9	79.0	79.0	15.8
50	10	50	129.0	64.5	64.5	12.9

**Table 7.4** Calculation for smoothing the concentration of batch wastewater dumps. Initial tank volume is  $V_0 = 5 \text{ m}^3$ .

### 7.7 Smoothing Mass Loads

Smoothing the flow rate to a treatment process will also smooth the mass load. The 20 random batch volumes in Table 7.3 vary from 1 to 10 m<sup>3</sup>. The pollutant concentrations of the batches vary from 2 to 8 kg/m<sup>3</sup> (2,000 to 8,000 mg/L). The mass of pollutant in a batch varies from 72 to 2 kg/m<sup>3</sup>. This 10 to 1 variation in volume and 35 to 1 variation in mass load would produce shock after shock to a waste treatment process. Smoothing will be beneficial.

**#1**  
in eco-friendly attitude

**STUDY AT LINKÖPING UNIVERSITY, SWEDEN**  
RANKED AMONG TOP 50 UNIVERSITIES UNDER 50

Interested in Strategy and Management in International Organisations? Kick-start your career with a master's degree from Linköping University, Sweden.

→ **Click here!**

 **Linköping University**



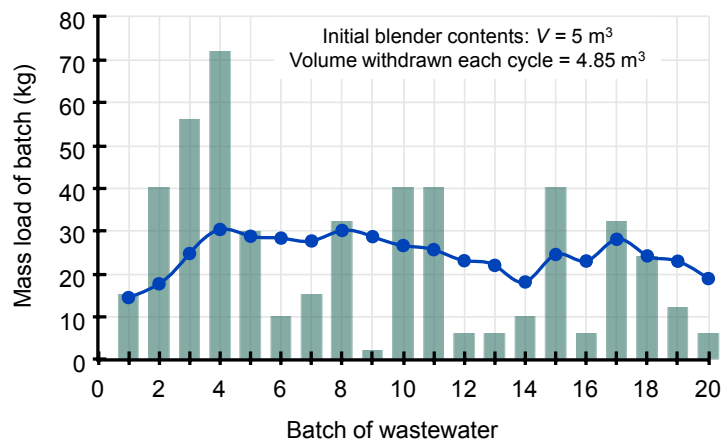
The total volume of the 20 batches is 97 m<sup>3</sup> and the total pollution mass load is 494 kg, giving an average mass load of 494 kg/20 = 24.7 kg per batch, or 494 kg/94 m<sup>3</sup> = 5.25 kg/m<sup>3</sup>.

Figure 7.7 shows the results for an initial blender volume = 5 m<sup>3</sup> and the initial blender contents concentration = 3 kg/m<sup>3</sup>, giving an initial mass of pollutant in the blender of (5 m<sup>3</sup>)(3 kg/m<sup>3</sup>) = 15 kg. The volume removed is a uniform 4.85 m<sup>3</sup> per batch.

Even a small blender is quite effective because the volumes and concentrations are both random, and random variation is the easiest kind to smooth. The 35/1 range in mass load has been reduced to about 3/1.

Batch	Volume Added (m <sup>3</sup> )	Mass Added (kg)	Volume in blender (m <sup>3</sup> )	Mass in Blender (kg)	Conc. in Blender (kg/m <sup>3</sup> )	Vol. at cycle end (m <sup>3</sup> )	Mass Removed (kg)	Mass at cycle end (kg)	Conc. at cycle end (kg/m <sup>3</sup> )
<i>Starting values =</i>						5		15	3
1	5	15	10.00	30.00	3.00	5.15	14.55	15.45	3.00
2	10	40	15.15	55.45	3.66	10.30	17.75	37.70	3.66
3	8	56	18.30	93.70	5.12	13.45	24.83	68.87	5.12
4	9	72	22.45	140.87	6.27	17.60	30.43	110.43	6.27
5	6	30	23.60	140.43	5.95	18.75	28.86	111.57	5.95
...	...	...	...	...	...	...	...	...	...
19	3	12	11.70	55.54	4.75	6.85	23.02	32.52	4.75
20	3	6	9.85	38.52	3.91	5.00	18.97	19.55	3.91

**Table 7.5** Summary of mass load smoothing calculations. The starting condition for the blender are  $V = 5 \text{ m}^3$ ,  $C = 3 \text{ kg/m}^3$ , and  $\text{Mass} = (5 \text{ m}^3)(3 \text{ kg/m}^3) = 15 \text{ kg}$ . The volume removed at the end of each cycle is the average batch size of 4.85 m<sup>3</sup>. The mass removed = (4.85 m<sup>3</sup>) (Conc. in blender after mixing the incoming batch).



**Figure 7.7** The smoothed mass load for 20 batches that have random volume and concentration. The mass load of each batch is shown by the bar. The smoothed mass output of the blender is shown by the line.

## 7.8 Dynamic Response of Continuous Flow Reactors

Batch operations, as discussed in the previous section, are common when relatively small volumes of material are processed, as one might see in pharmaceuticals, brewing, and tanning. Continuous-flow reactors are more common in water and wastewater treatment.

We use the term *reactor* even though the flow in these examples carries an inert tracer so there is no reaction. The focus is on the behavior of the reactor.

A *plug-flow reactor (PFR)* is a long tube or tank that has no mixing along the axis of the reactor. This is an idealization. Every real tank has some mixing, if only from the turbulence of the flowing fluid, but this can often be ignored, as we do here.

The theoretical *hydraulic detention time*,  $\theta$ , of a reactor is the volume,  $V$ , divided by the flow rate,  $Q$ .

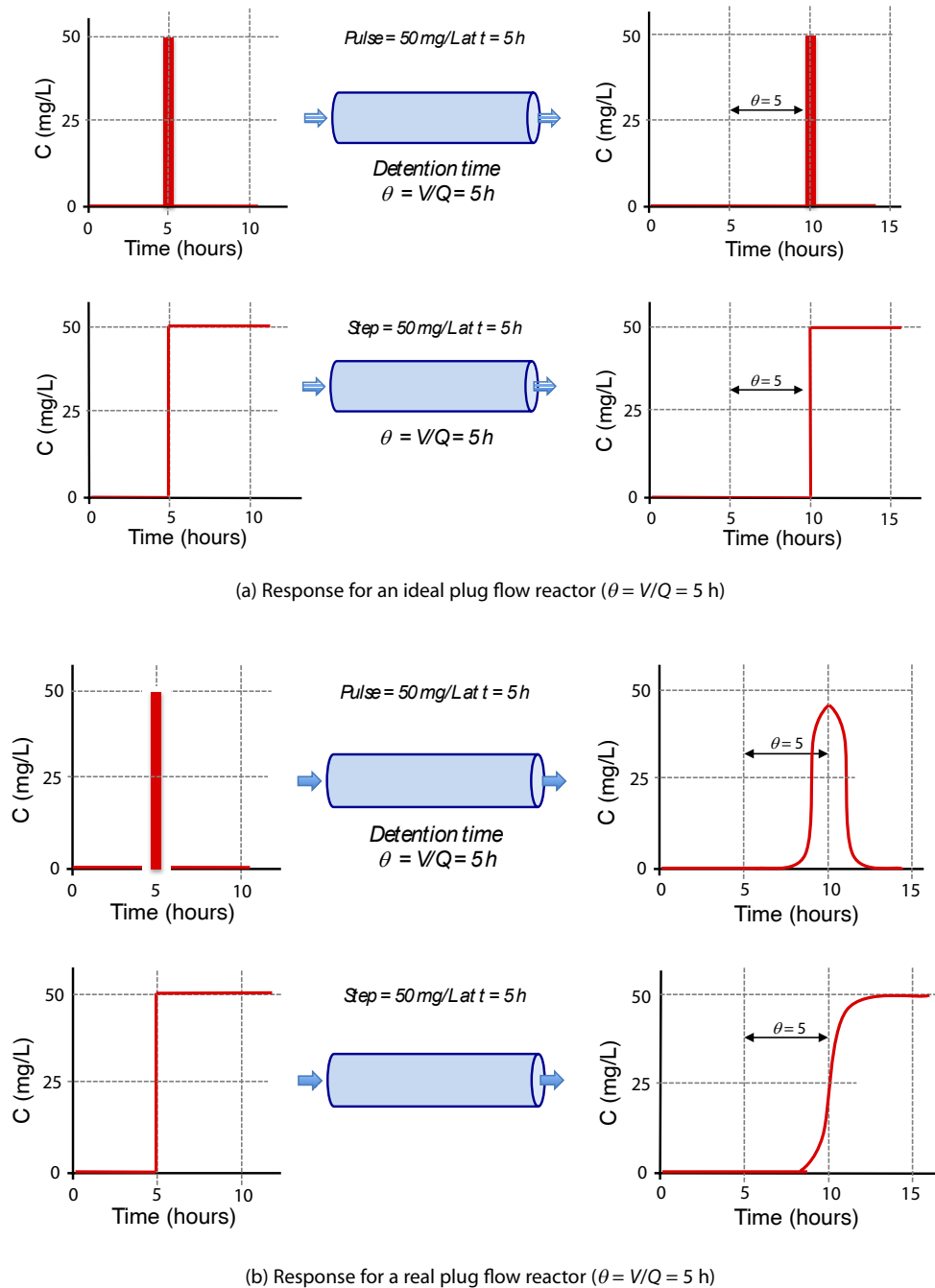
$$\theta = V/Q$$

This is the average length of time that a fluid element is held within the reactor volume.

In the examples that follow,  $\theta = V/Q = 5$  h, which is chosen arbitrarily. This could result when  $V = 10$  and  $Q = 2$ , or with many other values of  $V$  and  $Q$ . We will assume that  $V = 50 \text{ m}^3$  and  $Q = 10 \text{ m}^3/\text{h}$ .

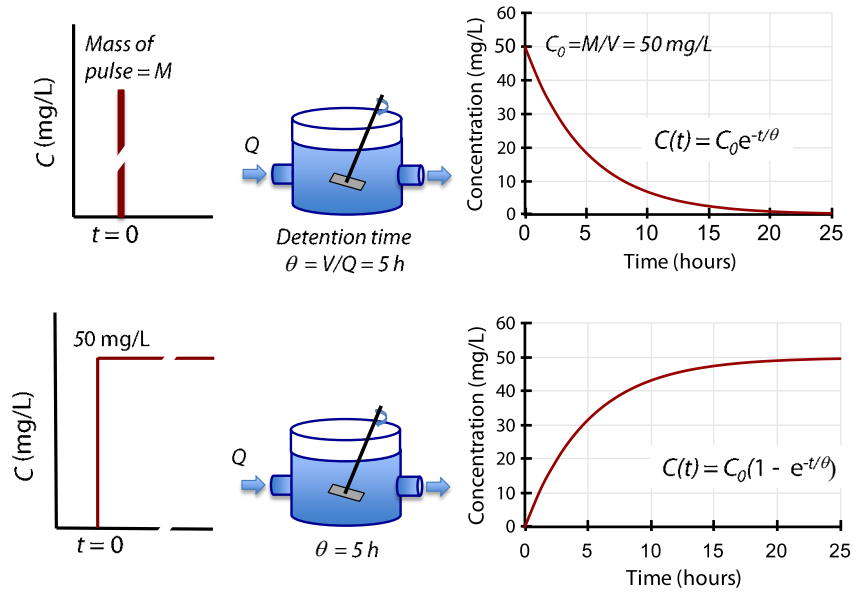
Figure 7.8(a) shows an ideal plug-flow reactor with detention time,  $\theta = 5$  h. Whatever enters the tank at time  $t$  leaves at time  $t + \theta$ . In the top panel, a pulse of 50 mg/L enters at  $t = 5$  h and exits at  $t = 5 + \theta$ . In the bottom panel the concentration steps from 0 mg/L to 50 mg/L and stays at that level indefinitely. The step at the inlet occurs at  $t = 5$  h and it appears at the reactor exit and at  $t = 5 + \theta = 10$  h.

Figure 7.8(b) shows a more realistic reactor that has some mixing along the direction of flow (i.e. axial mixing), as would result from natural turbulence. The slight distortion between the ideal and the more realistic effluent can usually be ignored. This is the case in the transport of material in rivers and pipelines. In estuaries and reservoirs, and in reactors that are aerated or otherwise mixed, plug flow is a poor reactor model.



**Figure 7.8** An ideal plug-flow reactor conveys material without intermixing along the reactor axis. A pulse that enters at time  $t = 5$  h leaves the reactor as an identical pulse one hydraulic detention time later. In this case the detention time is 5 hours. A more realistic reactor has some axial mixing, but this can often be ignored.

Figure 7.9 shows the behavior of an ideal continuous stirred tank reactor (CSTR), which is mixed so well that the contents are homogeneous. That is, whatever enters the tank is instantaneously mixed with the contents and the concentration is the same everywhere in the tank. It follows that the concentration of the effluent, no matter where it may be withdrawn, is the same as the concentration in the reactor.



**Figure 7.9** The response of an inert tracer in a stirred continuous-flow reactor that has constant volume and is stirred so the contents are homogeneous at any given time. The hydraulic detention time is 5 hours.

The model, for a CSTR of constant volume  $V$ , flow rate  $Q$ , and detention time  $\theta = V/Q$ , is

$$C(t) = C_0 \exp\left(-\frac{Q}{V}t\right) = C_0 \exp\left(-\frac{t}{\theta}\right)$$

“I studied English for 16 years but...  
...I finally learned to speak it in just six lessons”  
Jane, Chinese architect

ENGLISH OUT THERE

Click to hear me talking before and after my unique course download

The top panel of the diagram shows a pulse (or slug) of inert tracer coming into the CSTR in an amount that causes the concentration in the tank to immediately increase from zero to 50 mg/L. For a reactor volume of  $V = 50 \text{ m}^3$ , a 2.5 kg pulse of tracer will produce the 50 mg/L concentration.

After the sudden 2.5 kg input, the influent is free of tracer and the concentration of tracer in the tank decreases exponentially as it washes out. At one detention time (whatever value it may be), the concentration will be reduced by about two-thirds. For this example,  $C_0 = 50 \text{ mg/L}$  and  $\theta = 5 \text{ h}$ , and

$$C(t) = 50 \exp\left(-\frac{t}{\theta}\right) = 50 \exp(-1) = 50(0.3679) = 18.4 \text{ mg/L}$$

After three detention times the tracer in the reactor and in the effluent is 5% of the initial concentration. At five detention times the concentration is less than 1%.

A step input (lower panel of Figure 7.9) causes the concentration to increase from zero to the level of the step concentration, 50 mg/L in this series of examples. The model is

$$C(t) = C_0 \left[ 1 - \exp\left(-\frac{Q}{V}t\right) \right] = C_0 \left[ 1 - \exp\left(-\frac{t}{\theta}\right) \right]$$

For  $C_0 = 50$  and  $\theta = 5$

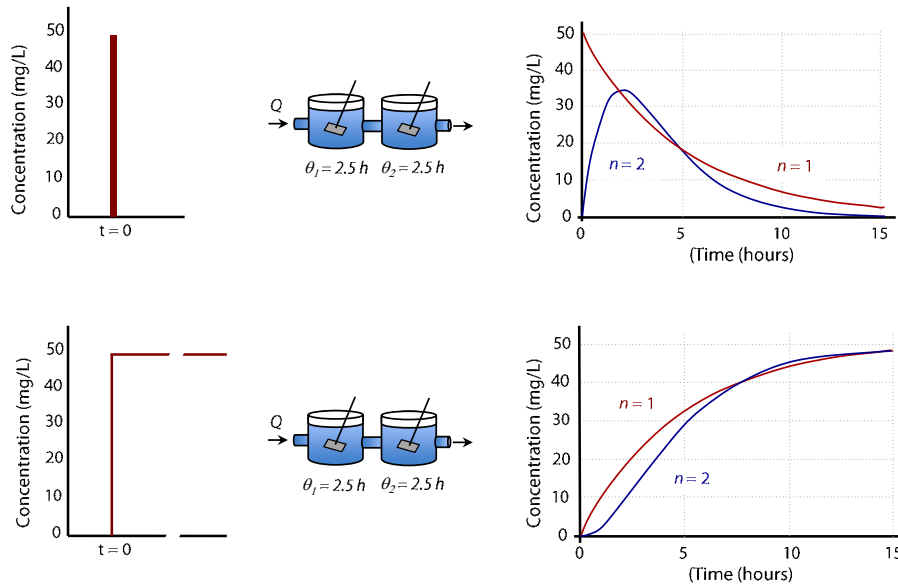
$$C(t) = 50 \left[ 1 - \exp\left(-\frac{t}{5}\right) \right]$$

For  $t = 5$ ,  $C(t=5) = 31.6$ ; for  $t = 10$ ,  $C(t=10) = 43.2$

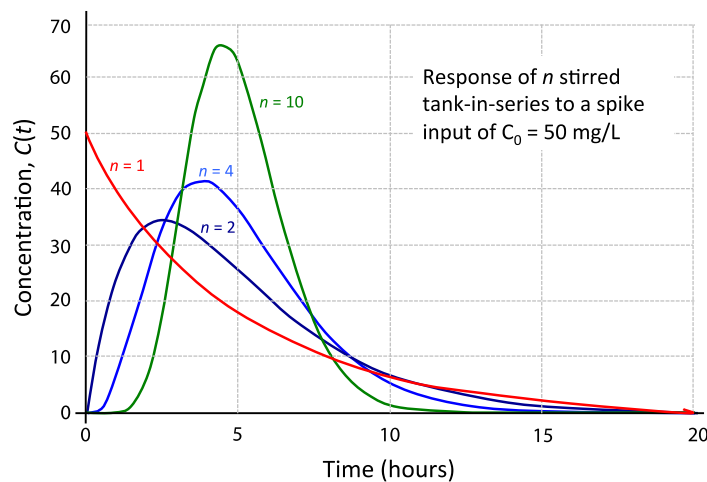
The CSTR is another idealization, but there are reactors that are vigorously mixed with mechanical agitators or aeration and do closely approximate the ideal.

- A neutralization tank may have a detention time of 10 to 30 minutes, compared with a time of 10-30 seconds to uniformly distribute the neutralizing chemicals throughout the tank. There is no significant error in treating the reactor as an ideal CSTR.
- Aeration tanks in the activated sludge biological treatment process are thoroughly mixed by the large volumes of air that are injected to sustain the aerobic bacteria that are cultured to degrade the waste. An ideal CSTR, or a series of two or three CSTRs, is an adequate model for the process.
- The wind-mixed upper layer (the epilimnion) of a stratified lake is often modeled as a CSTR. The same can be done for the virtually unmixed bottom layer (the hypolimnion), not because it is well mixed but because it is homogeneous. During turnover a deep lake or reservoir actually does become homogeneous.





**Figure 7.10** The response of an inert tracer in two CSTRs in series. Both reactors have constant volume and are stirred so the contents are homogeneous at any given time. The total hydraulic detention time is 5 hours, as in Figure 7.9.



**Figure 7.11** Response of  $n$  stirred tanks-in-series to a spike input of  $C_0 = 50$  mg/L.

Figure 7.10 shows the response of two CSTRs in series. The tanks are constant volume, each with a detention time of 2.5 h, so the total detention is 5 h, the same as the example in Figure 7.9. Figure 7.11 shows the behavior of  $n = 1, 2, 4$  and  $10$  tanks-in-series. The total detention time of the  $n$  tanks is  $\theta = 5$  h and the tanks have identical and constant volumes. It is interesting, and probably unexpected, that adding more tanks-in-series makes the system behave more and more like a plug flow reactor with axial mixing. This makes tanks-in-series models a convenient way to approximate many real reactor configurations.

The equation derivations have been omitted because, for most people, what is useful is to have a picture of the dynamics in your mind. This picture is a reminder that one or two stirred tanks reduce the ‘shock’ of sudden changes in the input.

## 7.9 Numerical Solutions

The response of any reactor to changes in input conditions can be approximated by using iterative calculations over small time intervals. Consider a step change in input to a CSTR (lower panel of Figure 7.9).

When the volume ( $V$ ) and the flow rate ( $Q$ ) are constant the model becomes

$$\frac{\Delta(VC)}{\Delta t} = QC_{in} - QC$$

Rate of change  
in mass
Rate of  
mass inflow
Rate of  
mass outflow

$C$  is the concentration of the reactor contents and the effluent.

For constant volume ( $V$ ), constant flow rate ( $Q$ ), and detention time ( $\theta = V/Q$ ), the model becomes

$$V \frac{\Delta C}{\Delta t} = QC_{in} - QC$$

$$\frac{\Delta C}{\Delta t} = \frac{Q}{V} C_{in} - \frac{Q}{V} C = \frac{1}{\theta} (C_{in} - C)$$

where  $\theta = V/Q$  is the hydraulic detention time.

Excellent Economics and Business programmes at:



**university of  
 groningen**





“The perfect start  
of a successful,  
international career.”

[www.rug.nl/feb/education](http://www.rug.nl/feb/education)

**CLICK HERE**  
to discover why both socially  
and academically the University  
of Groningen is one of the best  
places for a student to be



The change in concentration is

$$\Delta C = \frac{1}{\theta}(C_m - C)\Delta t$$

The concentration after one small time step of  $\Delta t$  is

$$C_{t+\Delta t} = C_t + \Delta C_t$$

Here are the first three time intervals for a step change in concentration from 0 mg/L to 50 mg/L, for the conditions  $V = 1$ ,  $Q = 5$ ,  $\theta = V/Q = 0.2$  and  $\Delta t = 0.1$ .

$$\Delta C_0 = \frac{1}{0.2}(50 - 0)0.1 = 1.00$$

$$C_{t=0.1} = 0 + \Delta C_0 = 0.1$$

$$\Delta C_{0.1} = \frac{1}{0.2}(50 - 0.1)0.1 = 0.9800$$

$$C_{t=0.2} = 0.1 + \Delta C_{0.1} = 0.1 + 0.9800 = 1.0800$$

$$\Delta C_{0.2} = \frac{1}{0.2}(50 - 1.08)0.1 = 0.9604$$

$$C_{t=0.3} = 1.0800 + \Delta C_{0.2} = 1.0800 + 0.9604 = 2.0404$$

This simple arithmetic was repeated 250 times to simulate 25 hours of flow through the stirred reactor. The partial results are in Table 7.6. The right hand column in Table 7.6 is the exact solution. The difference between the numerical approximation and the exact solution is unimportant in an application such as this.

Making  $\Delta t$  smaller will improve the accuracy of the estimation.

Time (h)	$C_{in}$ (mg/L)	$C_{out}$ (mg/L)	$\Delta C_t$ (mg/L)	$C_t = 50[1 - \exp(-t/\theta)]$ (mg/L)
-0.1	0	0	0	0
0	50	0	1	0
0.1	50	1	0.9800	0.99
0.2	50	1.9800	0.9604	1.96
0.3	50	2.9404	0.9412	2.91
0.4	50	3.8816	0.9224	3.84
0.5	50	4.80	0.9039	4.76
...	...	...	...	...
1	50	9.15	0.8171	9.06
...	...	...	...	...
2	50	16.62	0.6676	16.48
...	...	...	...	...
4	50	27.71	0.4457	27.53
...	...	...	...	...
5	50	31.79	0.3642	31.61
...	...	...	...	...
10	50	43.37	0.1326	43.23
...	...	...	...	...
25	50	49.68	0.0064	49.66

**Table 7.6** Numerical approximation of the response of a CSTR to a step change from 0 to 50 mg/L in the inlet concentration.  $V = 1$ ,  $Q = 5$ ,  $\theta = V/Q = 5$ , and  $\Delta t = 0.1$ .

A new term is added to the material balance equation when there is a chemical reaction. For the case of a chemical that disappears at a rate proportional to the concentration of the chemical in the reactor the term is  $(-kCV)$ , where  $k$  is a rate coefficient. The change in mass in the continuous-flow stirred tank reactor over a small time interval,  $\Delta t$ , is

$$\frac{\Delta(VC)}{\Delta t} = \underbrace{QC}_{\text{Change Inflow}} - \underbrace{QC}_{\text{Outflow}} - \underbrace{kCV}_{\text{Reaction}}$$


In the example above, the chemical was an inert material (a non-reactive tracer) so there was no reaction ( $k = 0$ ).

We have shown the numerical approximation that can be used by anyone who does not know calculus and differential equations. Also it can be adapted to more complicated systems where it may be difficult to find an analytical solution to the differential equations. (Anyone who is interested in the differential equations can find them in numerous books and on-line articles.)

## 7.10 Case Study – Municipal Activated Sludge Process

Figure 7.12 shows the flow, activated sludge process influent BOD and effluent BOD, measured at 2-hour intervals over a ten day period, at the Nine Springs Wastewater Treatment plant in Madison, WI. This data is for 1976, which is ancient history for this treatment plant, but the influent patterns today are the same and the levels are somewhat higher.

The maximum inflow every day is about twice the minimum flow, ranging from 23 mgd to 48 mgd. The day with the lowest flow is Sunday. The strength of the influent to the activated sludge aeration basin typically ranges daily between 125 mg/L BOD<sub>5</sub> at night to 200 mg/L BOD<sub>5</sub> during the day. The raw wastewater entering the treatment plant varied between 170 mg/L and 260 mg/L. This means that the mass load of BOD coming into the treatment process changes by a factor of about 4 every 24-h diurnal cycle.




In the past four years we have drilled  
**89,000 km**  
That's more than **twice** around the world.


**Who are we?**  
We are the world's largest oilfield services company<sup>1</sup>.  
Working globally—often in remote and challenging locations—we invent, design, engineer, and apply technology to help our customers find and produce oil and gas safely.

**Who are we looking for?**  
Every year, we need thousands of graduates to begin dynamic careers in the following domains:

- Engineering, Research and Operations
- Geoscience and Pettechnical
- Commercial and Business

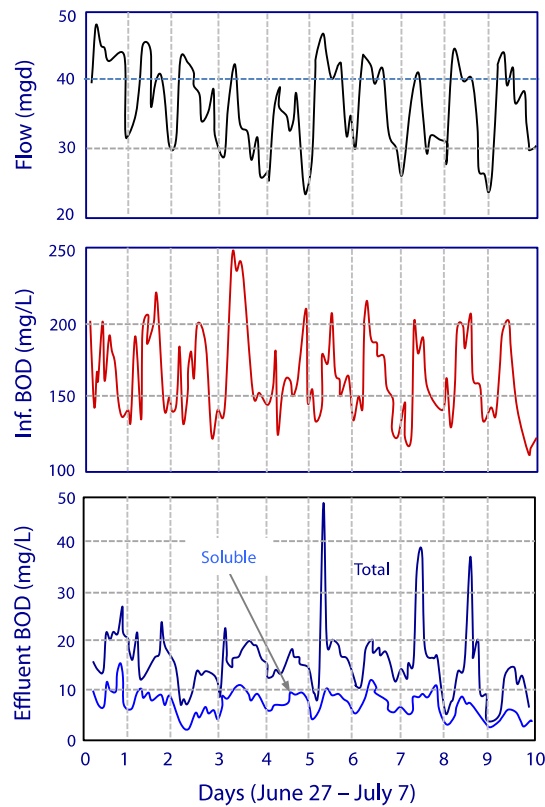
**What will you be?**

 careers.slb.com

 Schlumberger

<sup>1</sup>Based on Fortune 500 ranking 2011. Copyright © 2015 Schlumberger. All rights reserved.





**Figure 7.12** The dynamic behavior of a conventional activated sludge wastewater treatment plant (Madison, WI, 1976) before the process was modified for nitrification and biological phosphorus removal.

The bottom panel of Figure 7.12 shows the effluent BOD from the activated sludge process. The total effluent BOD varies between 10 and 20 mg/L, except for three spikes, and the soluble BOD varies between 5 and 10 mg/L. The spikes are caused ineffective removal of suspended solids and they correspond to high flow during the day.

This old conventional process did a good job of absorbing the four to five-fold fluctuations of the influent load ( $\text{flow} \times \text{BOD}$ ). There are three reasons for this. The process had a long detention time, about 10 hours, a high concentration of bacteria was maintained in the system, and the reactor was essentially three stirred tanks-in-series. Stirred tanks buffered changes in influent concentration and having several tanks in series increased the buffering and blending that occurred.

The plant was upgraded in the 1980s to do nitrification and again in the 1990s for biological phosphorus removal. Since then the average effluent SS and BOD are about 2 mg/L, despite the same diurnal influent loading change of at least four to one.

## 7.11 Conclusion

Unsteady-state dynamics are normal in real environmental systems. The behavior of many important real natural and constructed processes can be understood by analyzing ideal reactors.

It is often acceptable to assume steady-state conditions for design. Common practice is to analyze a system at a maximum, minimum, and average loading. If good performance is indicated at these conditions, the system is expected to handle the normal dynamic variations, unless the changes are shockingly fast and large.

Two exceptions are flow equalization and blending, which are strongly unsteady state and must be modeled that way. The analysis is easily done with a series of simple material balance calculations.

Numerical (iterative) procedures often give excellent approximate solutions when exact analytical solutions of differential equations are difficult or unavailable.



**American online**  
**LIGS University**  
is currently enrolling in the  
Interactive Online **BBA, MBA, MSc,**  
**DBA and PhD** programs:

- ▶ enroll **by September 30th, 2014** and
- ▶ **save up to 16%** on the tuition!
- ▶ pay in 10 installments / 2 years
- ▶ Interactive **Online education**
- ▶ visit [www.ligsuniversity.com](http://www.ligsuniversity.com) to find out more!

**Note: LIGS University is not accredited by any nationally recognized accrediting agency listed by the US Secretary of Education. More info [here](#).**





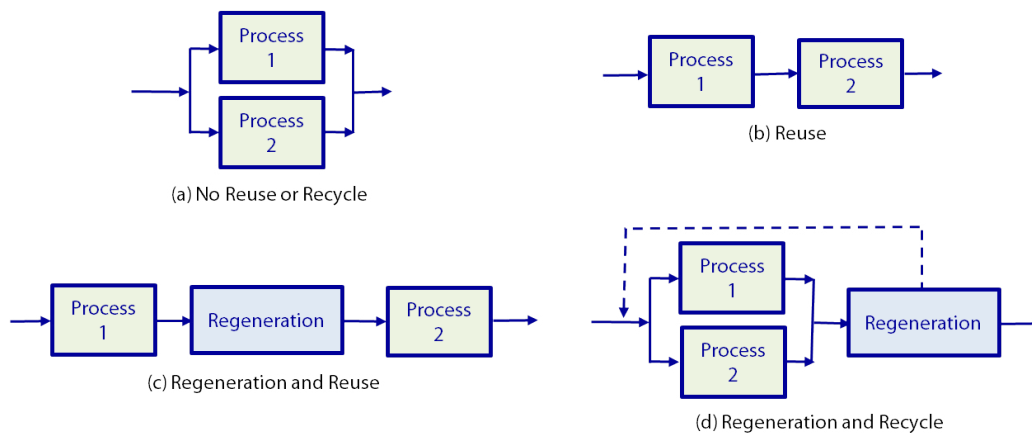
# 8 Water Conservation and Reuse

## 8.1 The Design Problem

Water conservation sustains the available water supply, protects fresh water habitats, reduces the need for building new storage reservoirs, eliminates or postpones the expansion of existing water and wastewater treatment plants, conserves energy, and stabilizes the price of water. Sustainability demands that the withdrawal of fresh water from an ecosystem should not exceed its natural replacement rate. Sadly, many parts of the world, and the United States, are operating at unsustainable rates of water use.

Figure 8.1 shows four ways that water use could be arranged in a simple two-process system. A common way is (a), which might be necessary because neither Process 1 nor Process 2 has an output that is suitable in terms of water quality or volume for use in the other.

Arrangement (b) will be attractive when the water quality leaving Process 1 makes a suitable input for Process 2. The water quantities do not need to be identical; the Process 1 effluent could be augmented or diluted with fresh water, or a portion of it could bypass Process 2. The processes might be in the same industry or in neighboring industries, or they might be a municipal wastewater treatment plant and a cooling tower or irrigation system.



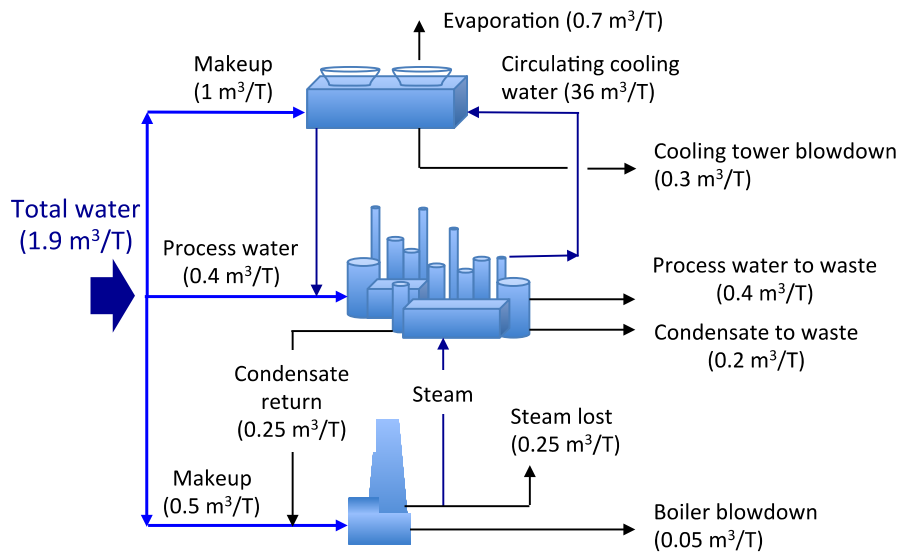
**Figure 8.1** Arrangements for water reuse, regeneration, and recycle.

It may be technically feasible to upgrade an effluent from one process for reuse in another. If so, the cost of regeneration will be weighed against the savings in fresh water and wastewater treatment cost. Arrangement (c) shows poor quality effluent from Process 1 being reused in Process 2 after regeneration, which might be to adjust the pH, or to remove dissolved salts, suspended solids, or an undesirable gas. An environmental system that has this same pattern is a wastewater effluent discharge to a river, which provides the regeneration, with subsequent withdrawal for irrigation or drinking water supply.

Panel (d) combines regeneration and recycle. Obviously there can be several combinations of these two strategies. This scheme could be used for two different industries, for example a power plant using high quality sewage effluent for cooling.

## 8.2 Industrial Water Cycle

Industry uses water in the manufacturing process, and for cooling and heating, as shown in Figure 8.2.



**Figure 8.2** The industrial water cycle includes process water, cooling water, and steam for heating.

Boilers and cooling towers are recirculating systems. With each cycle of reuse some water is lost, by evaporation in cooling towers and by steam losses in boilers. The evaporated water and lost steam carry no salts with them so the salt concentration of the recirculating water increases. The salt concentration is controlled by removing a portion of the salt-laden circulating water and replacing it with fresh water. The water that is removed is *cooling tower blowdown* or *boiler blowdown*. The fresh water that is added is called *makeup water*. Makeup will equal blowdown plus other losses, including evaporation. Table 8.1 indicates plausible quantities for three types of systems.

Type of System	Water circulation (gal/min)	Evaporation (gal/day)	Blowdown (gal/day)	Makeup (gal/day)
Air conditioner tower	10,000	200,000	70,000	270,000
Refinery	150,000	4,300,000	1,000,000	5,300,000
Large Power Plant	400,000	11,500,000	2,500,000	14,000,000

**Table 8.1** Industrial water use in cooling systems

### 8.3 Cooling Towers

Cooling towers may be natural draft or forced draft. Both use evaporative cooling. Natural draft cooling towers are dependent on temperature gradients between air and water and the wind forces. Forced draft cooling towers use fans and blowers to circulate air and control the evaporation. The efficiency of natural draft towers is more variable over time and in general lower.

Figure 8.3 shows a recycle cooling water system. Water pumped from the tower basin is the cooling water routed through the process coolers and condensers in an industrial facility. The cool water absorbs heat from the hot processes that need to be cooled or condensed, and the absorbed heat warms the circulating water.

The warm water returns to the top of the cooling tower and, as it trickles down the fill material in the tower, ambient air rises through the tower, either by natural draft or by forced draft. This causes a small amount of the water to be lost as drift ( $D$ ) and a large amount to evaporate ( $E$ ). The heat required to evaporate the water is derived from the water itself, which cools the water so it is ready to recirculate.

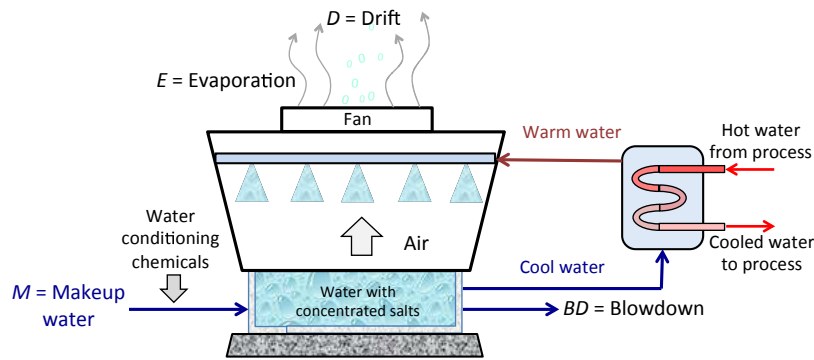
.....Alcatel-Lucent 

[www.alcatel-lucent.com/careers](http://www.alcatel-lucent.com/careers)

What if you could build your future and create the future?

One generation's transformation is the next's status quo. In the near future, people may soon think it's strange that devices ever had to be "plugged in." To obtain that status, there needs to be "The Shift".

 [Click on the ad to read more](#)



**Figure 8.3** The water balance for a fan-induced forced draft cooling tower.  $M = BD + E + D$

*Evaporation* removes heat from the circulating water, but it does not remove dissolved minerals. *Drift*, the uncontrolled blowing of water droplets from the tower, removes both water and minerals; it is functionally the same as blowdown. A new tower in good condition, with drift eliminators, loses about 0.005% of the recirculating water via drift.

*Blowdown* is the intentional, controlled removal of mineral-laden water from the cooling system. Blowdown is quantified by the term *cycles of concentration* or simply *cycles*. Cycles are equal to the ratio of make-up water volume to blowdown water volume, assuming that drift and spills are negligible.

*Fresh water makeup* ( $M$ ) is supplied to replace evaporation loss, drift loss, and blowdown.

Figure 8.3 is the basis for the material balance on a wet, evaporative cooling tower system. The flow rates and concentrations are:

$M$  = Makeup water ( $\text{m}^3/\text{h}$ )

$BD$  = Draw-off (blowdown) water ( $\text{m}^3/\text{h}$ )

$E$  = Evaporated water ( $\text{m}^3/\text{h}$ )

$D$  = Drift loss of water ( $\text{m}^3/\text{h}$ )

$TDS_{BD}$  = Blowdown concentration of TDS (or chlorides) (ppm or mg/L)

$TDS_M$  = Makeup water concentration of TDS (or chlorides) (ppm or mg/L)

The water balance is:

$$M = E + D + BD$$

For convenience, drift is considered as part of the blowdown.

$$M = E + BD$$

Since the evaporated water ( $E$ ) has no salts, the material balance on dissolved solids is simple. The dissolved solids entering with the makeup water must leave with the blowdown.

$$M \times TDS_M = BD \times TDS_{BD}$$

The average number of times the water is circulated through the cooling tower is the *cycles of concentration*, or simply *cycles*. If the mineral in the recirculating water were four times as concentrated as in the make-up water, the tower would be running at 4 cycles.

$$\text{Cycles} = \frac{TDS_{BD}}{TDS_M} = \frac{M}{BD} = \frac{M}{M - E} = 1 + \frac{E}{BD}$$

Most cooling towers operate in the range of 3 to 7 cycles. This depends on the quality of the makeup water supply. Well water usually has high levels of dissolved solids. On the other hand New York City has a surface rainwater source that is low in minerals and cooling towers in that city are often able to operate at 7 or more cycles.

Municipal wastewater effluent, or other reclaimed water, has been used to replace a portion of the makeup water in cooling systems.

#### Example 8.1 COOLING TOWER SYSTEM

An air conditioning cooling tower system uses 180m<sup>3</sup>/d of makeup water that is purchased from the city. Corrosion inhibitors and biocides are added and the makeup has a total dissolved solids (TDS) concentration of 500 mg/L. The blowdown has TDS = 3,000 mg/L. The makeup water will be changed to 50% city water plus 50% reclaimed water at 1,800 mg/L TDS. The 50-50 mixture will have TDS = (1,800 mg/L + 500 mg/L)/2 = 1,150 mg/L.

The original water balance for 100% city water makeup is

$$E = \text{Evaporation} = 150 \text{ m}^3/\text{d}$$

$$BD = \text{Blowdown} = 30 \text{ m}^3/\text{d} \text{ (drift is included in the blowdown)}$$

$$M = \text{Makeup} = 180 \text{ m}^3/\text{d}$$

$$\text{Cycles} = M/BD = 180/30 = 6 \quad \text{or} \quad \text{Cycles} = TDS_{BD} / TDS_{\text{city}} = 3,000/500 = 6$$

Operation with 50% reclaimed water has these characteristics

$$\text{TDS of makeup water mixture} = 1,150 \text{ mg/L}$$

$$\text{Cycles} = 3,000/1,150 = 2.6$$

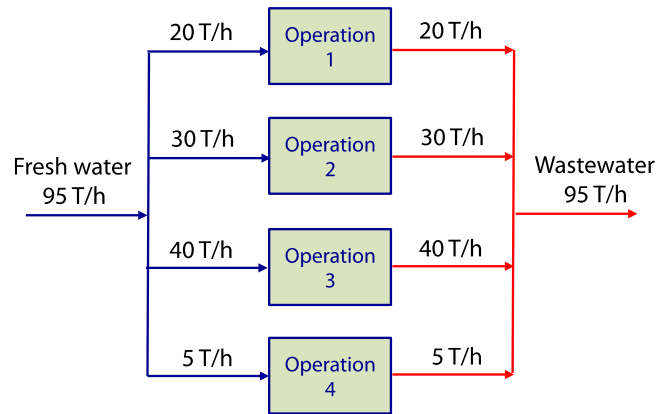
$$BD = E/(\text{cycles} - 1) = 150/1.6 = 94 \text{ m}^3/\text{d}$$

$$\text{Makeup} = E + BD = 150 + 94 = 244 \text{ m}^3/\text{d}$$

The new operation uses 122 m<sup>3</sup>/d reclaimed water plus 122 m<sup>3</sup>/d city water. This reduces city water purchases by 58 m<sup>3</sup>/d, or 20,000 m<sup>3</sup>/y, a substantial savings.

## 8.4 Process Water Reuse

The design goal is to move away from the wasteful approach shown in Figure 8.4, where water is used once and discarded. Reducing the intake of fresh water simultaneously reduces the output of wastewater, thus saving money at both ends of the system. This is not a process flow diagram; only the flow of water is being shown. The example is unrealistically simple because no water is lost or consumed.



**Figure 8.4** A system that has no water reuse or recycle (Source: (Foo, et al. 2006, Manan, et al. 2004).

'Fresh water' is a generic description of the supply that is available to service processes. It may be from a river (e.g. cooling water), a city water supply, a well, a water softening plant (boiler feed water), or a deionization plant (high purity water for electronics manufacture). A large industry may use 'fresh water' of different qualities in different sections of the plant.



Join the best at  
the Maastricht University  
School of Business and  
Economics!

**Top master's programmes**

- 33<sup>rd</sup> place Financial Times worldwide ranking: MSc International Business
- 1<sup>st</sup> place: MSc International Business
- 1<sup>st</sup> place: MSc Financial Economics
- 2<sup>nd</sup> place: MSc Management of Learning
- 2<sup>nd</sup> place: MSc Economics
- 2<sup>nd</sup> place: MSc Econometrics and Operations Research
- 2<sup>nd</sup> place: MSc Global Supply Chain Management and Change

Sources: Keuzegids Master ranking 2013; Elsevier 'Beste Studies' ranking 2012; Financial Times Global Masters in Management ranking 2012

**Maastricht University is the best specialist university in the Netherlands (Elsevier)**

**Visit us and find out why we are the best!**  
**Master's Open Day: 22 February 2014**

[www.mastersopenday.nl](http://www.mastersopenday.nl)



If water quality requirements are ignored and only the quantity of water is considered, the water leaving Operations 1, 2 or 3 could supply the 5 T/h needed in Operation 4. The 40 T/h from Operation 3 could supply Operation 1, Operation 2, Operations 1 and 4, or Operations 2 and 4. The 30 T/h of effluent from Operation 2 could supply Operations 1 or 4.

Some of these matches will not be feasible because of water quality requirements, but making the matches based on mass flow or volume flow is an interesting exercise.

Figure 8.5 shows two arrangements of water reuse that have a 60 T/h fresh water input and a 60 T/h wastewater output, which is 35 T/h less than the scheme in Figure 8.4. In one case, water from Operation 3 is reused in Operations 2 and 4. In the other, water from Operations 2 and 4 is reused in Operation 3. (There is at least one other arrangement that uses less water and we leave its discovery as an exercise for the reader.)

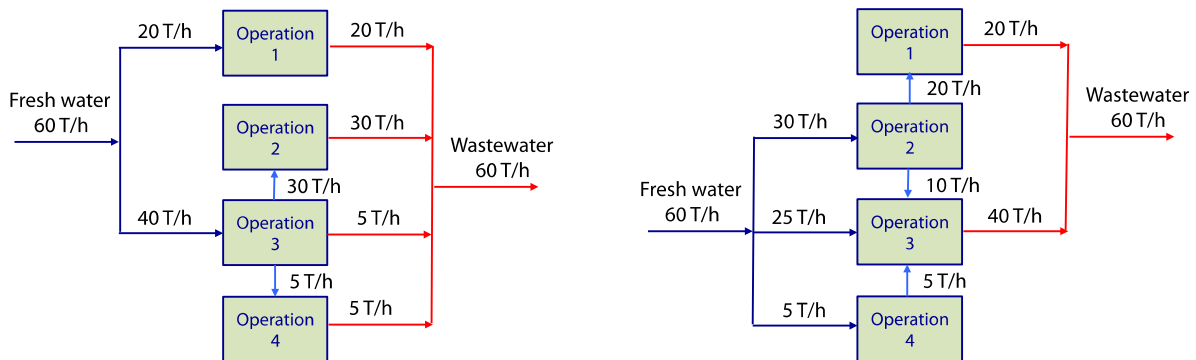


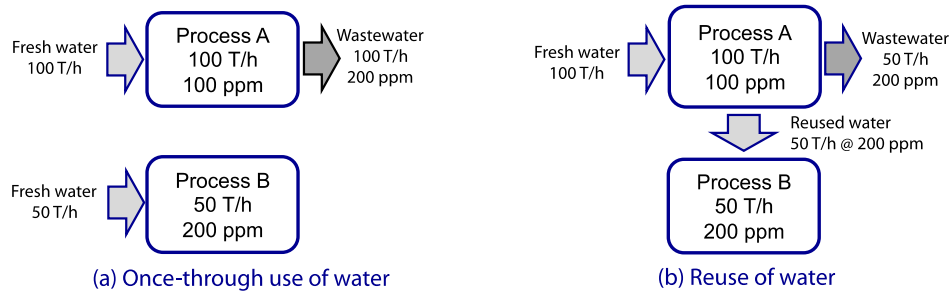
Figure 8.5 Two systems redesigned to incorporate water reuse with an almost 40% savings.

## 8.5 Water Reuse and Water Quality

Once-through water use can be reduced if one process can accept used effluent from another. Figure 8.6(a) shows a once-through system that uses 100 T/h in Process A and 50 T/h in process B, for a total of 150 T/h of fresh water. Process B fully consumes the 50 T/h input.

Process A can accept water with 100 ppm of pollutant (e.g., salts). It discharges water with 200 ppm pollutant. Process B can accept water with 200 ppm pollutant, so it can be supplied by the effluent from Process A. This scheme, shown in Figure 8.6(b), uses only 100 T/h and discharges half the amount of wastewater.





**Figure 8.6** Once-through water use can be reduced if one process can accept used water from another.

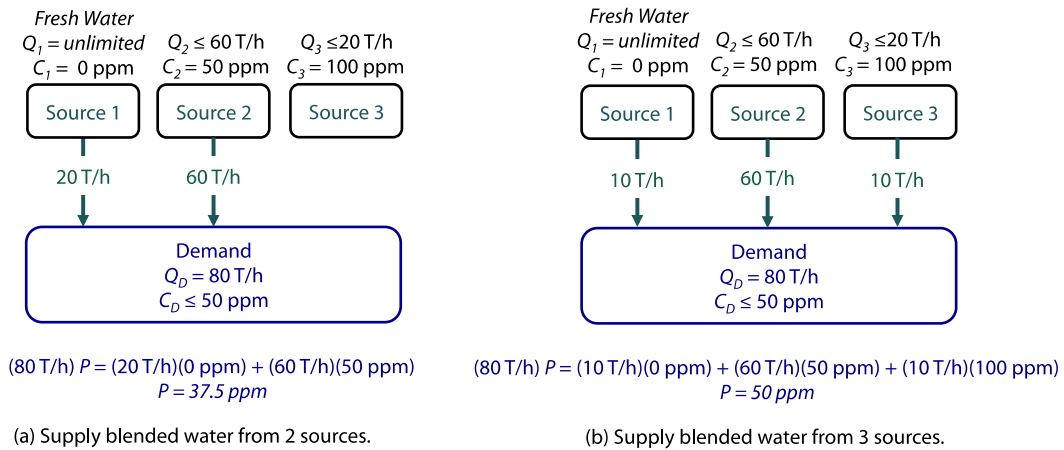
The nearest neighbor rule is a simple way to match water sources and demands when pollutant level is an issue. The rule is:

- Satisfy a demand by using water from the neighbor sources that are nearest to the demand in terms of the pollutant concentration.
- If a single preferred source cannot satisfy the demand, use all that is available from the preferred source and blend water from the next nearest neighbor to satisfy the remaining demand.
- A source that is just cleaner and a source that is just dirtier than the demand are mixed to satisfy the demand.

Figure 8.7 shows a demand for 80 T/h of water that has a pollutant concentration not to exceed 50 ppm ( $C_D \leq 50$  ppm). One possibility is to supply 80 T/h of fresh water, but the goal is to reuse water from sources 2 and 3, which have pollutant concentrations of  $C_2 = 50$  ppm and  $C_3 = 100$  ppm.

The neighbor source that is nearest the demand specification is Source 2, which has a pollutant concentration  $C_2 = 50$  ppm, but it can supply only 60 T/h of the required 80 T/h. Adding 20 T/h fresh water give an 80 T/h supply with pollutant level 37.5 ppm, as shown in Figure 8.7(a). This leaves  $Q_3 = 20$  T/h of the most highly polluted water going to wastewater.

A better option is to use  $Q_2 = 60$  T/h,  $Q_3 = 10$  T/h and  $Q_1 = 10$  T/h. This is the scheme in Figure 8.7(b). The mixture of  $Q_1 + Q_3 = 20$  T/h has a concentration of 50 ppm and so does the mixture of  $Q_1 + Q_2 + Q_3 = 80$  T/h. This scheme uses less fresh water and discharges only 10 T/h of wastewater.



**Figure 8.7** Illustration of the nearest neighbor rule to match water supply and demand (water sources and sinks).

## 8.6 Mass Exchange Operations

There is a class of processes that chemical engineers call *mass-exchange operations*. Mass-exchange operations have in common a transfer of mass from a rich stream to a lean stream. Figure 8.8 shows three examples of some substance being added or removed from water.

**> Apply now**

REDEFINE YOUR FUTURE  
**AXA GLOBAL GRADUATE PROGRAM 2015**

redefining / standards **AXA**

agence.cdg. © Photonistop

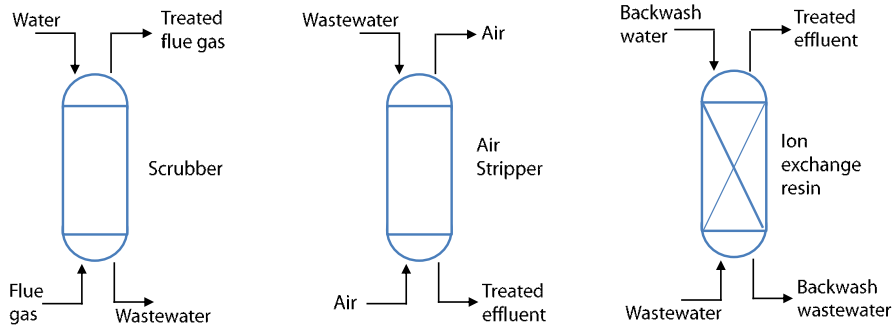


Figure 8.8 Three examples of mass-exchange operations.

Figure 8.9 describes a mass exchange process in terms of the inlet and outlet concentrations, and as a function of the mass transferred from one stream to the other. The right-hand panel is a diagram of this information with the  $x$ -axis in units of mass load,  $m$ , and the  $y$ -axis in units of concentration,  $C$ . Only the stream that gains pollutant is shown in these diagrams.

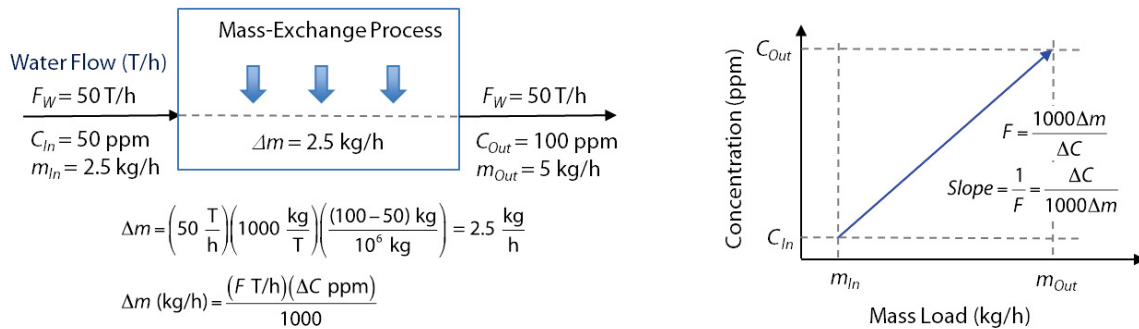


Figure 8.9 Contaminant mass transfer in water

The mass load is

$$m = \frac{FC}{1,000}$$

where  $m$  = mass flow (kg/h)

$F$  = Flow rate (T/h)

$C$  = concentration (ppm = kg/10<sup>6</sup> kg)

The change in mass across a process is

$$\Delta m = \frac{F \Delta C}{1,000}$$

where  $\Delta m$  = change in mass across the process (kg/h)

$\Delta C$  = change in concentration across the process (ppm = kg/10<sup>6</sup> kg)

The slope of the line in the  $C$  vs.  $m$  plot, right-hand panel of Figure 8.9, is the inverse of the flow rate.

$$\text{Slope} = \frac{1}{F} = \frac{\Delta C}{1,000 \Delta m}$$

The flow rate of water determines the concentration of contaminant exiting from the operation. This is shown in Figure 8.10. Figure 8.10a shows the condition when the water flow rate is reduced, and the contaminant concentration at the outlet increases. Figure 8.10b shows the condition where the inlet concentration and flow rate are reduced, while maintaining the outlet concentration.

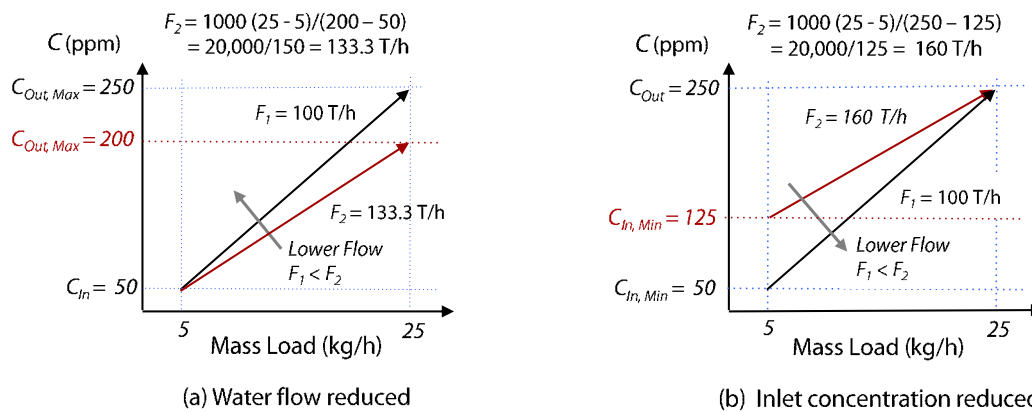


Figure 8.10 Concentration of contaminant is a function of flow rate.

## 8.7 The Composite Mass-Concentration Curve

The system from Figure 8.4 will be used to illustrate these ideas (Foo, et al. 2006, Manan, et al. 2004). Information about the maximum allowable inlet concentrations,  $C_{In, Max}$ , and output concentrations,  $C_{Out}$ , are given in Table 8.2. The input concentration can be less, but not more, than the maximum concentration. The increase in mass across the process,  $\Delta m$ , is fixed and will be added to the mass that enters the process.

Operation 1 has an input of fresh water ( $C_{In} = 0$ ). The mass entering is 0 kg/h and the mass exiting is 2 kg/h. The flow rate that will carry 2 kg/h at a concentration of 100 ppm is 20 T/h.

Operation	$\Delta m$ (kg/h)	$C_{Out}$ (ppm)	$F = \text{Flow rate}$ when $C_{In} = 0$ (T/h)	$C_{In, Max}$ (ppm)	$\Delta C$ $= C_{Out} - C_{In, Max}$ (ppm)	$F = \text{Flow rate}$ when $C_{In} = C_{In, Max}$ $F = 1000\Delta m/\Delta C$
			$F = 1000\Delta m/(C_{Out})$			$F = 1000\Delta m/(C_{out} - C_{In, Max})$
1	2	100	20	0	100	$2000/100 = 20$
2	6	200	30	50	150	$6000/150 = 40$
3	10	800	12.5	100	700	$10000/700 = 14.3$
4	2	800	2.5	400	400	$2000/400 = 5$

Table 8.2 Water quality constraints for the system shown in Figure 8.4.

For Operation 2, the input of fresh water that will carry 6 kg/h with an output concentration of 200 ppm is 30 T/h. If the input has the maximum allowable concentration of 50 ppm, and an output concentration of 200 ppm, the flow rate must increase to 40 T/h. If the input concentration is somewhere between freshwater ( $C = 0$  ppm) and the maximum allowed (50 ppm), the flow rate must be between 30 T/h and 40 T/hr.

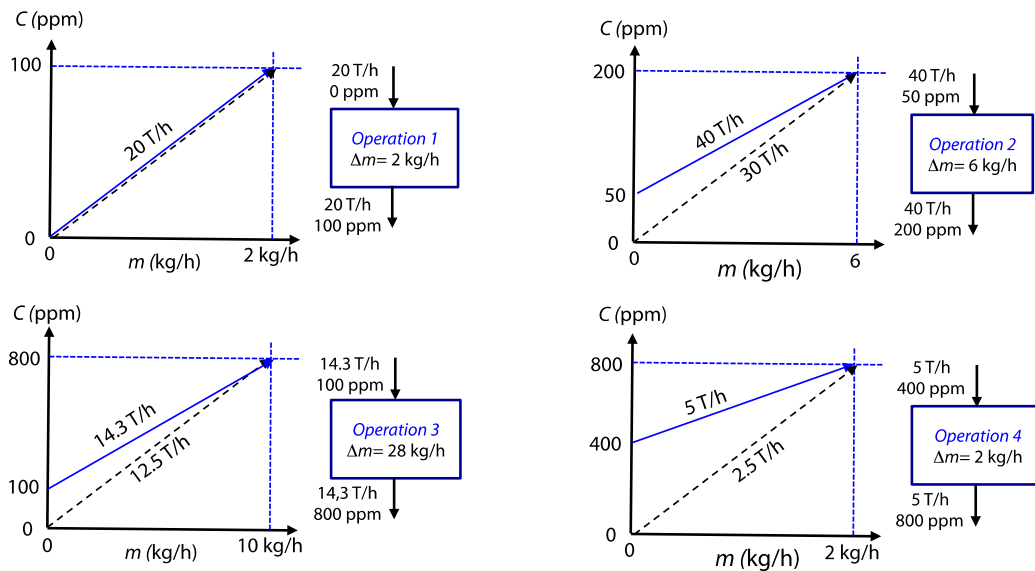


Figure 8.11 Mass-concentration plots for four example operations.

**BI** NORWEGIAN BUSINESS SCHOOL

EFMD EQUIS ACCREDITED

## Empowering People. Improving Business.

BI Norwegian Business School is one of Europe's largest business schools welcoming more than 20,000 students. Our programmes provide a stimulating and multi-cultural learning environment with an international outlook ultimately providing students with professional skills to meet the increasing needs of businesses.

BI offers four different two-year, full-time Master of Science (MSc) programmes that are taught entirely in English and have been designed to provide professional skills to meet the increasing need of businesses. The MSc programmes provide a stimulating and multi-cultural learning environment to give you the best platform to launch into your career.

- MSc in Business
- MSc in Financial Economics
- MSc in Strategic Marketing Management
- MSc in Leadership and Organisational Psychology

[www.bi.edu/master](http://www.bi.edu/master)



The dashed arrows in Figure 8.11 show the mass-concentration diagrams for the four operations with fresh water input ( $C_{in} = 0$  ppm) and at the outlet concentration determined by the mass transfer that occurs within the operation.

The *maximum flow rates* (blue arrows) corresponding to the *maximum* input concentrations can be used to construct the *composite concentration curve* shown in Figure 8.12(a). It is a *composite curve* because it collects the information for all operations into one graph. This curve gives a graphical solution for the minimum possible fresh water input.

These are the steps to construct the composite mass-concentration curve.

1. Order, from low to high, the operations on the basis of the maximum allowable input concentration.
2. For each operation, plot a line that covers the range ( $C_{In, Max}$ ,  $C_{Out}$ ) and  $\Delta m$ .
  - The quantities of  $\Delta m$  accumulate on the horizontal axis. The lines for the 4 operations are shown with blue arrows from the input condition to the output condition.
  - Red horizontal dotted lines show the intervals of concentration and  $\Delta m$  for each operation. For this problem there are 5 concentration levels, 1–50 ppm, 50–100 ppm, 100–200 ppm, 200–400 ppm, and 400–800 ppm.
3. The red-arrows in Figure 8.12(b) go upward from one concentration level to the next to cover the full range of concentrations and the full range of the accumulated transported mass flow. They are constructed, starting with the lowest concentration interval, by drawing a line covering the range of concentrations in each interval and the range of mass flows from each operation active in that interval, and repeating this over all concentration intervals.

Thus for the first concentration interval (0–50 ppm), only Operation 1 is active, and the composite line goes from [0,0] to [1,50]. For the second interval (50–100ppm), Operations 1 and 2 are active and the composite line goes from [1,50] to [4,100]. For the third interval (100–200 ppm), Operations 2 and 3 are active and the composite line goes from [4,100] to [~9.4, 200]. The process is repeated over all concentration intervals to get the complete composite concentration diagram in Figure 8.12(b).

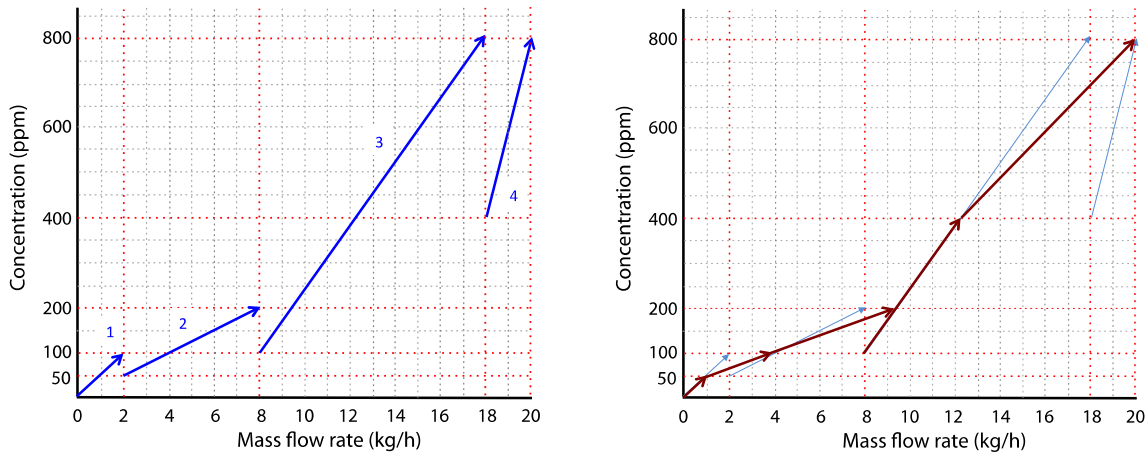


Figure 8.12 (a) Mass-concentration curves for the four operations and (b) the composite mass-concentration curve.

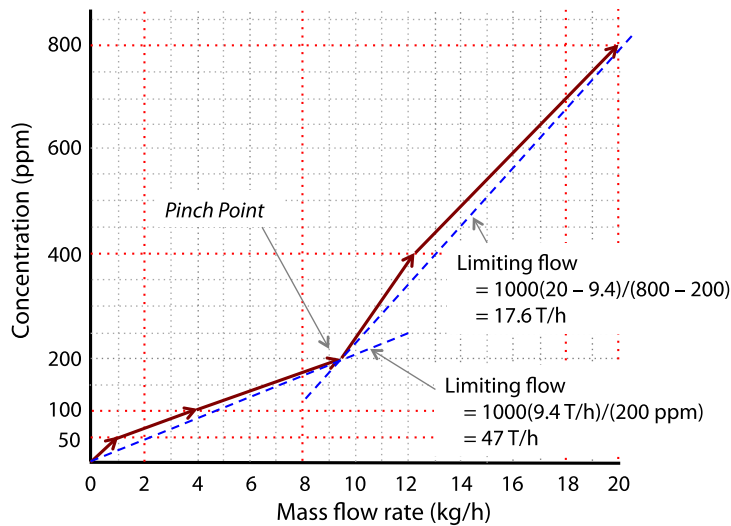


Figure 8.13 Graphical solution of the composite mass-concentration curve for the minimum fresh water input of 47 T/h.

Figure 8.13 is the graphical solution for the minimum fresh water input. Draw a straight line from the origin to locate the vertex (intersection of two lines) with the largest mass flow that can be intersected without going above the mass-concentration composite curve.

This vertex is called the *pinch point*. The location of the pinch point is important because the process does not require fresh water above this point. Water from elsewhere in the system can be reused above the pinch point. Therefore, the minimum water flow rate with water reuse is the flow rate required to reach the pinch point.



This line from the inlet concentration through the pinch point has a slope of  $1/F_{Min}$ , where  $F_{Min}$  is the minimum flow rate with water reuse.

$$F_{min} = 1000 \left( \frac{\Delta m}{C_{Pinch} - C_{In}} \right)$$

For this example the construction identifies the vertex at a mass flow rate of 9.4 T/h and a concentration of 200 ppm. The inverse slope of this line is the water flow rate

$$\text{Limiting flow (T/h)} = \frac{1000(9.4 \text{ kg/h})}{200 \text{ ppm}} = 47 \text{ T/h}$$

Figure 8.14 shows the implementation. The water requirement, when worked out more exactly than the graphical solution gives, is 47.14 T/h. Fresh water must supply Operation 1 because the input concentration is specified to be  $C_{In} = 0$ . The Operation 1 output, with concentration 100 ppm, can be diluted with fresh water to supply Operation 2, which accepts a pollutant level of 50 ppm. This means that Operation 1 is zero discharge and Operation 2 uses 50% less fresh water, both desirable outcomes.

Operation 3 can accept Operation 2 effluent when it is diluted with fresh water.

Operation 4 can accept Operation 2 effluent directly to satisfy its water demand.

## Need help with your dissertation?

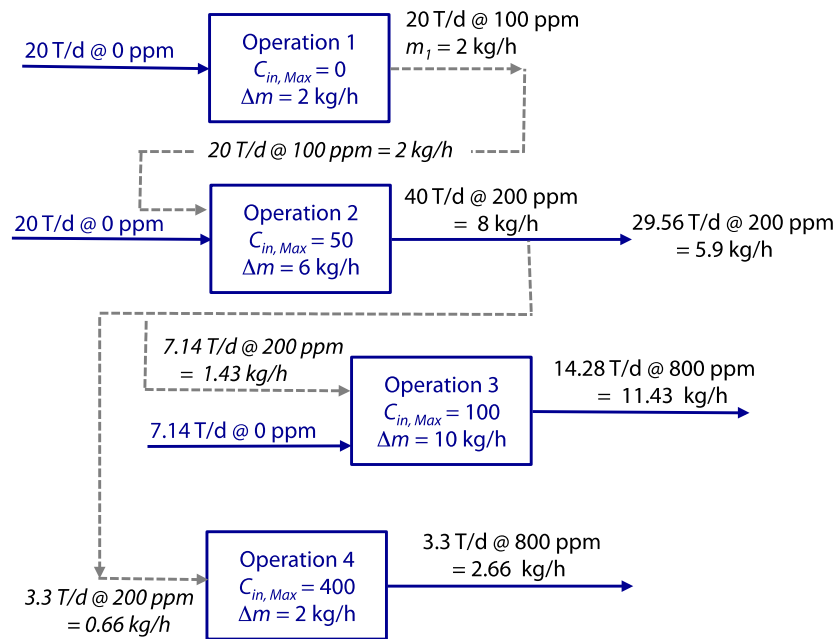
Get in-depth feedback & advice from experts in your topic area. Find out what you can do to improve the quality of your dissertation!

Get Help Now



Go to [www.helpmyassignment.co.uk](http://www.helpmyassignment.co.uk) for more info

 **Helpmyassignment**



**Figure 8.14** Water reuse scheme. Fresh water input = 47.14 T/h; Wastewater output = 47.14 T/h. Pollutant transferred in the four operation is  $\Delta m = 20 \text{ kg/h}$ ; pollutant in the wastewater = 20 kg/h.

## 8.8 Conclusion

Recirculating systems, cooling towers for example, conserve water by increasing the cycles of reuse before discharge. The conservation efficiency is increased if once-used water from other sources, such as a municipal wastewater treatment plants, can be used for makeup water.

An industry often can find opportunities to reduce the intake of fresh water by recycling used water from one process to another. The composite mass-concentration diagram is a tool for analyzing these possibilities. The examples in this chapter consider only a single contaminant. Extending the formal analysis to multiple contaminants is complicated, but the strategy of cascading water from process to process, so long as the water quality does not interfere with the processing, is sound.

# 9 Accounting for Energy

## 9.1 The Design Problem

Designing systems to manage the flow of energy is much like designing systems to manage the flow of materials. In existing systems we can measure temperatures, electrical use, steam flow, and fuel burned and make a balance on the energy entering and leaving the system. The energy flow of systems on the drawing board (in the CAD system) cannot be measured, so it is calculated. Because energy is not lost, the amount entering a system or process equals the amount leaving. The energy balance is the designer's counterpart to the material balance.

The energy balance is based on an empirical principle called the first law of thermodynamics, which states that heat and work are convertible. Energy in a system can change from one form to another (e.g., from mechanical to electrical), but the total amount of energy does not change. No exception to the first law has ever been observed so the energy balance principle applies to all natural and engineered processes and systems.

Much of our concern with energy has to do with converting it from one form to another. Chemical energy in natural gas is converted to thermal energy in steam, which is converted to mechanical energy in a turbine, which is converted into electrical energy. Each conversion is inefficient, due in part to restrictions imposed by Nature and in part to technology. This needs to be understood to make predictions about how much heat can be obtained from burning different kinds of fuels, and how much useful energy can be obtained from machinery.

The energy balance is used to answer such questions as:

- How much heat energy can be obtained from one ton of fuel oil?
- How much steam can be produced from one ton of fuel oil?
- How much electricity can be produced from one ton of fuel oil?
- How much energy is required to pump water into an elevated tank?
- How much heat energy can be recovered from the hot exhaust gas from a gas engine?
- Does a sludge digester produce enough biogas to heat the sludge that is fed to the digester?

In many problems the changes in energy are inconsequential, like the change in heat energy (temperature) of water as it flows through a settling tank, so an energy balance is not needed. The reverse is not true. Whenever an energy balance for a process is needed, material flow information will be needed, such as the mass of water converted to steam, the mass of oil entering a boiler, and the volume and mass rate of flow of flue gas and its components.

For example, most energy and water conservation problems involve the flow of heat energy in water or steam that are used for heating and cooling. The simultaneous flow of heat and mass explains why reducing water use usually reduces energy use, and using less energy often allows a reduction in water.

This and the following chapters deal with the law of conservation of energy and the basic principles of thermodynamics, but only in simple situations. We will be able to account for the flow of energy as materials flow through a processing system and to approximate the heat available from burning different fuels, including waste materials. More complicated problems are in the realm of the mechanical and chemical engineer.

## 9.2 Conservation of Energy – The First Law of Thermodynamics

There are many forms of energy: gravitational, kinetic, heat, elastic, electrical, chemical, radiant, nuclear, and mass energy. Energy can be changed into various forms, but a balance can always be made to account for it. This is the first law of thermodynamics – the principle of conservation of energy.

“There is no known exception to the law of conservation of energy ... It is not a description of a mechanism, or of anything concrete; it is just a strange fact that we can calculate some number and when we finish watching nature go through her tricks and calculate the number again, it is the same. (Feynman 1996).”



**Brain power**

By 2020, wind could provide one-tenth of our planet's electricity needs. Already today, SKF's innovative know-how is crucial to running a large proportion of the world's wind turbines.

Up to 25 % of the generating costs relate to maintenance. These can be reduced dramatically thanks to our systems for on-line condition monitoring and automatic lubrication. We help make it more economical to create cleaner, cheaper energy out of thin air.

By sharing our experience, expertise, and creativity, industries can boost performance beyond expectations. Therefore we need the best employees who can meet this challenge!

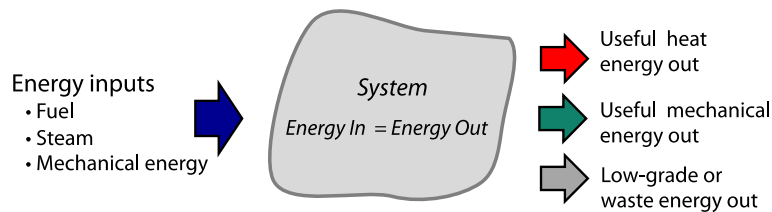
The Power of Knowledge Engineering

Plug into The Power of Knowledge Engineering.  
Visit us at [www.skf.com/knowledge](http://www.skf.com/knowledge)

**SKF**

The law of conservation of energy is analogous to the law of conservation of mass. The law of conservation of energy is the basis for an energy balance.

Figure 9.1 shows an enclosed volume or system over which the energy balance is to be made. We are not concerned with the internal details, only with the passage of energy across the system boundaries. Energy crossing the boundary may be associated with a mass of flowing material, or it can cross the boundary as the flow of heat, for example, transferred across the surface of a heat exchanger. Or, it could enter in the form of fuel that releases its energy upon combustion, or as chemicals that react to consume or release heat.



**Figure 9.1** All energy that enters an enclosed volume of the system must accumulate in or leave the system.

We will study energy balances that involve heating, cooling, and combustion processes that operate at constant pressure. In constant pressure processes the energy balance is analogous to the material balance, with enthalpy (kJ/kg or kJ/L) taking on the role of concentration (mg/kg or mg/L). If the process is not at constant pressure, vapors and gases expand and contract and a thermodynamic function called entropy must be used in the analysis. These processes are important but they will not be covered in this book.

For the case where no energy accumulates within the process boundary, the energy balance is

$$\text{Total energy in} = \text{Total energy out}$$

Each term in the equation must have the same units (Joule, kWh, Btu, etc.).

**Example 9.1 ENERGY RECOVERY IN INTERNAL COMBUSTION ENGINES**

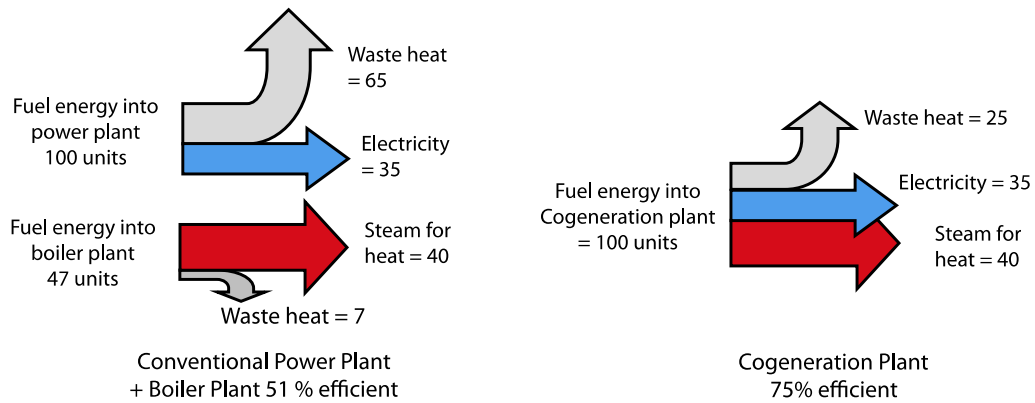
The chemical energy released from fuel that is burned in an internal combustion engine leaves the engine in these ways.

Useful mechanical work	30–38%
Hot jacket water	20–26%
Hot lubricating oil	2–8%
Hot exhaust gas	30–37%
Radiation from metal parts	1–10%

If the hot jacket water is passed through a radiator that cools the water by dumping heat to the air, the energy in the jacket water is wasted. In stationary installations such as engines that drive pumps, generators, compressors, it is possible to recover about 20 percent of the heat from the jacket water, about 13 percent from the exhaust, and perhaps some more from the hot lubricating oil, to bring the overall thermal efficiency from 30 – 38% up to the range of 50 to 70%.

**Example 9.2** COMBINED HEAT AND POWER (CHP)

Combined Heat and Power (CHP), also called Cogeneration, is the generation of electricity plus the recovery of heat. A typical CHP system is 70–80% efficient, while the separate generation of electricity and heat has a combined efficiency of about 50%. The comparison is shown in Figure 9.2, where separate power generation and steam heating plants have a combined energy input of  $100 + 47 = 147$  units to produce 35 units of electricity and 40 units of heat. The cogeneration plant has an input of 100 units to produce the same amount of electricity and steam heat, and is thus 75% efficient.



**Figure 9.2** Comparison of a conventional power plant and a cogeneration plant (CHP).

**What do you want to do?**

No matter what you want out of your future career, an employer with a broad range of operations in a load of countries will always be the ticket. Working within the Volvo Group means more than 100,000 friends and colleagues in more than 185 countries all over the world. We offer graduates great career opportunities – check out the Career section at our web site [www.volvogroup.com](http://www.volvogroup.com). We look forward to getting to know you!

**VOLVO**  
AB Volvo (publ)  
[www.volvogroup.com](http://www.volvogroup.com)

VOLVO TRUCKS | RENAULT TRUCKS | MACK TRUCKS | VOLVO BUSES | VOLVO CONSTRUCTION EQUIPMENT | VOLVO PENTA | VOLVO AERO | VOLVO IT  
VOLVO FINANCIAL SERVICES | VOLVO 3P | VOLVO POWERTRAIN | VOLVO PARTS | VOLVO TECHNOLOGY | VOLVO LOGISTICS | BUSINESS AREA ASIA



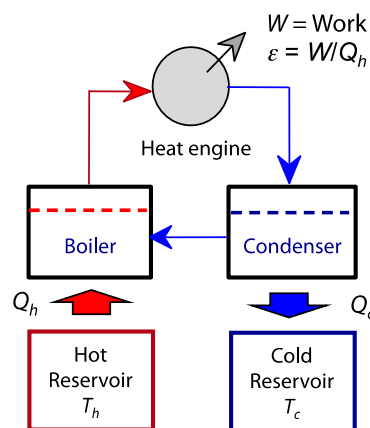


### 9.3 The Heat Trap – The Second Law of Thermodynamics

The laws of thermodynamics are:

- *First law:* Energy can be changed into various forms, but the total amount of energy is unchanged and a balance can always be made to account for it. This is the principle of conservation of energy.
- *Second law:* No machine is one hundred percent efficient in converting energy input into work output. It is impossible to devise a machine which working in a cycle shall produce no other effects than the extraction of heat from a reservoir and the performance of an equal amount of work.
- *Third law:* It is impossible to reduce the temperature of a system to absolute zero in a finite number of steps.

The second law explains the efficiency, or lack of efficiency, of energy conversions in heat engines. A heat engine converts thermal energy to mechanical energy, as in a fossil fuel power plant or internal combustion engine. The application to heat engines is shown in Figure 9.3, in which heat energy ( $Q_h$ ) is withdrawn from a hot reservoir and converted into work ( $W$ ) and waste heat ( $Q_c$ ). Work is energy which can in principle be quantitatively converted to the lifting of a weight. Heat is that part of total energy flow that is caused by a temperature difference.



**Figure 9.3** General heat engine.

The efficiency of the heat engine,  $\varepsilon$ , is the useful work produced per unit of energy withdrawn from the hot reservoir.

$$\varepsilon = W/Q_h$$



The inefficient conversion of thermal energy is a consequence of the second law of thermodynamics and not of inept engineering. The thermodynamic limit of the heat engine is a heat trap that cannot be avoided in any energy conversion scheme that involves operations with thermal energy. No heat engine can be more efficient than the theoretical Carnot engine and the efficiency of the Carnot engine is determined by the temperatures of the hot and cold reservoirs,  $T_h$  and  $T_c$ , measured in kelvins ( $K = ^\circ C + 273$ ).

$$\epsilon_{Carnot} = \frac{T_h - T_c}{T_h}$$

In theory the efficiency of a Carnot heat engine can be 100 percent only if the temperature reservoir to which heat is ejected is at absolute zero. (Scientists have been able to reach a temperature of 1 nanokelvin, which is one-billionth of a degree Kelvin. At this temperature it takes an atom half a minute to move one inch. The average temperature of the universe is 2.73 K.)

To improve the efficiency the temperature at which an engine receives its energy must be as high as possible and the temperature at which it rejects its waste heat must be as low as possible. The upper limit is determined by the endurance of materials of construction and is on the order of 600°C. The lower limit of the cold reservoir for most applications (power plants, automobiles, etc.) is the temperature of the surrounding air, land, or water, which is usually 10 to 20°C. These conditions give a Carnot efficiency of

$$\epsilon_{Carnot} = \frac{(600 + 273) - (15 + 273)}{(600 + 273)} = 0.67$$

**gaiTeye**  
*Challenge the way we run*

**EXPERIENCE THE POWER OF FULL ENGAGEMENT...**

**RUN FASTER.  
RUN LONGER..  
RUN EASIER...**

**READ MORE & PRE-ORDER TODAY  
WWW.GAITEYE.COM**

This describes a theoretical heat engine that must reject one-third of its energy as waste heat. Real engines reject as much as two-thirds of their input as waste heat.

Any real device that converts heat into work must be less efficient than a Carnot engine that operates over the same temperature range:

$$\varepsilon = \frac{W}{Q_h} < \frac{T_h - T_c}{T_h}$$

**Example 9.3 POWER PLANT WASTE HEAT**

A thermal electric power plant, Figure 9.4, burns 1,000,000 kg /day of coal that has a heating value of 9.35 kWh/kg (33.66 MJ/kg). The thermal efficiencies of the boiler, turbine, and generator are 80%, 45%, and 98%, respectively. The losses are waste heat.

Coal input = (1,000,000 kg/day coal)(9.35 kWh/kg) = 9,350,000 kWh (33,660,000 MJ)

Boiler efficiency = 80%

Energy transmitted to the turbine = (0.80)(9,350,000 kWh) = 7,480,000 kWh (26,930,000 MJ)

Energy lost with the exhaust gas = 1,870,000 kWh (6,730,000 MJ)

Turbine efficiency = 45%

Energy transmitted to the generator = (0.45)(7,480,000) = 3,366,000 kWh (12,120,000 MJ)

Energy lost with cooling water = 4,114,000 kWh (14,810,000 MJ)

Generator efficiency = 98%

Energy produced = (0.98)(3,366,000) = 3,300,000 kWh (11,880,000 MJ)

Energy lost as waste heat = 66,000 kWh (240,000 MJ)

About 100(3,300,000/9,350,000) = 35.3 % of the energy input is converted to electricity. Almost two-thirds of the energy input is lost from the power plant to the environment, mostly by rejection to cooling water in the condensers. The waste heat absorbed by the cooling water is subsequently dissipated in the river or to the atmosphere via evaporation in a cooling tower.

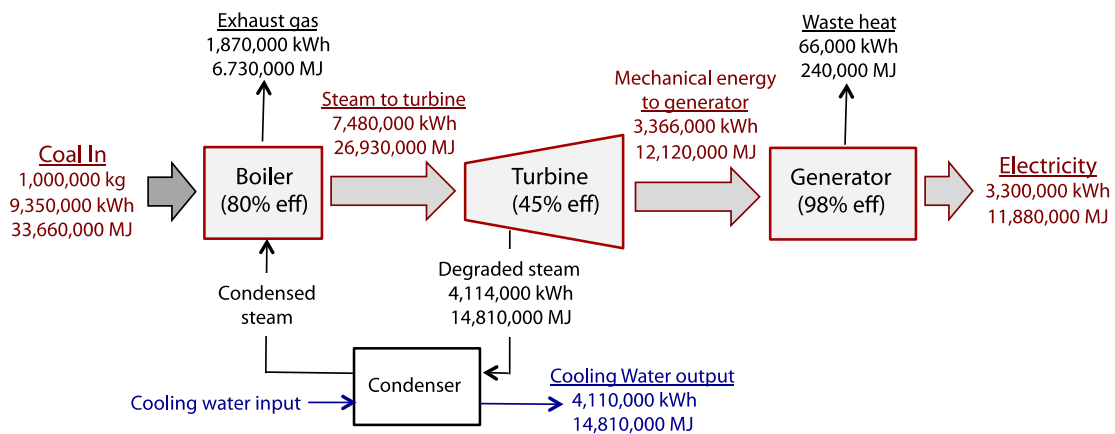


Figure 9.4. Thermal electric power plant.

## 9.4 Energy Units

The energy stored in water trapped behind a dam is called potential energy and is converted to kinetic energy as the water is released through the raceway of a hydroelectric plant. Kinetic energy is converted to mechanical energy by the water driven turbine and then to electric energy in a generator. The electric energy is converted to mechanical energy in electric motors, into chemical energy in charging batteries, and into heat for cooking and heating. The measurement units for these energy flows and transformations are varied because they involve units of force, mass, distance, time, and temperature.

Energy is defined as the capacity to do work. In physical terms

$$\text{Energy (work)} = \text{Force} \times \text{Displacement}$$

The *Newton* is that force which will give an acceleration of one meter per second per second to a mass of one kilogram. The *Joule* is the work done by a force of one Newton when its point of application is moved through a distance of one meter in the direction of the force. The Joule is used for the measurement of every kind of energy, including heat. The Newton-meter (N-m) and Joule (J) are identical in value.

Mechanical work energy has units of N-m = Joule (J) or foot-pound (ft-lb). Heat energy may be Joule, British thermal unit (Btu), kilocalorie (kcal).

Power is the rate of expending energy, or the rate of energy flow

$$\text{Power} = \text{change in (or flow of) Energy per unit time}$$

The *Watt* is the power experienced by an energy flow of one Joule per second. The Watt is used for the measurement of every kind of power. Power has units of J/s, = Watt (W), kilowatt (kW), ft-lb/sec, or horsepower (hp). Electric power is typically measured in kilowatts (kW) or megawatts (MW).

Mechanical power in the U.S. is normally reported as horsepower (hp), where  $1 \text{ hp} = 550 \text{ ft-lb/s} = 0.7457 \text{ kW} = 2.685 \text{ MJ}$ .

Finally, energy is often expressed as

$$\text{Energy} = (\text{Power})(\text{Time})$$

which has units of Watt-second (W-s), kilowatt-hour (kWh) or horsepower-hour (hp-h)

## 9.5 Arithmetic Equivalence of Energy Units

The arithmetic equivalence of energy units indicates how numerical values are converted from one set of units to another. It provides no useful information about the conversion of energy from one form to another. Table 9.1 lists some frequently needed energy and power equivalence factors.

Energy unit		Btu	kWh	Joules
1 kilowatt-hour (kWh)	=	3412	1	$3.6 \times 10^6$
1 Joule (J)	=	$9.478 \times 10^{-4}$	$2.778 \times 10^{-7}$	1
1 kilocalorie (kcal)	=	3.968	$1.163 \times 10^{-3}$	4184
1 British thermal unit (Btu)	=	1.0	$2.931 \times 10^{-4}$	1055
1 horsepower-hour (hp-h)	=	2544	0.7457	$2.685 \times 10^6$

Fuel Unit		Btu	kWh	Joules
1 barrel petroleum (bbl) [42 US gal]	=	$5.8 \times 10^6$	1700	$6.117 \times 10^9$
1 cubic foot of natural gas	=	1050	0.308	$1.108 \times 10^6$
1 gallon of gasoline	=	126,000	36.92	$133 \times 10^6$

Power Unit		kW	hp	Btu/h
1 kW	=	1.0	1.341	3,412
1 hp	=	0.7457	1.0	2,544
1 Btu/h	=	$2.931 \times 10^{-4}$	$3.930 \times 10^{-4}$	1.0

**Notes:** 1 Btu raises the temperature of 1 pound of water 1°F  
4184 J raises the temperature of 1 kg of water by 1°C

Table 9.1 Energy and Power Arithmetic Equivalence Factors

This e-book  
is made with  
**SetaPDF**





**SETASIGN**

PDF components for PHP developers

[www.setasign.com](http://www.setasign.com)



Most of the world measures energy in Joules and kilowatt-hours. The Joule is a small amount of energy. One Joule raises the temperature of 1 g of water by 0.239°C and it takes 4184 J to raise the temperature of 1 kg of water by 1°C. Also, 1 kWh = 3,600,000 J = 3,412 Btu. KiloJoules (kJ) or megaJoules (MJ) are more convenient units in most engineering problems.

The most commonly used units in the U.S. are kWh, Btu, and horsepower. Horsepower is widely used to measure the mechanical power of a motor or engine. Btu is a convenient measure of energy when mass is measured in pounds (lb), as one Btu will raise the temperature of one pound of water by one degree Fahrenheit (°F).

The examples in this book will use both metric units (Joules, Watt, °C) and Customary U.S. units (horsepower, Btu, °F).

**Example 9.4 HEAT ENERGY AND ELECTRIC ENERGY**

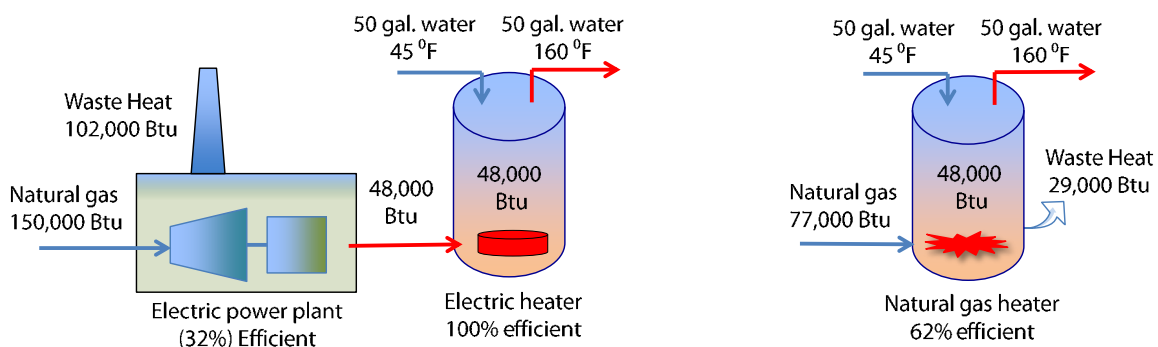
The energy released by burning one kilogram of West Virginia bituminous coal (4.5% ash, 1% S) is  $33.66 \times 10^6$  J. The arithmetic equivalent of electrical energy, using  $1 \text{ kWh} = 3.6 \times 10^6$  J from Table 9.1 is

$$(33.66 \times 10^6 \text{ J}) (1 \text{ kWh} / 3.6 \times 10^6 \text{ J}) = 9.35 \text{ kWh}$$

The heat energy released by the combustion of one kilogram of coal is arithmetically equivalent to the operation of a 100 W light bulb for 93.5 hr. Unfortunately, the efficiency of converting coal to electrical energy is only about 35%. The amount of electricity delivered from the generator is closer to 3.3 kWh. Some of that is used in the power plant and some (about 6%) is lost in transmission from the plant to the consumer. Therefore, the more realistic yield from 1 kg of coal is enough electrical energy to operate a 100 W light bulb for less than 30 hours.

**Example 9.5 WATER HEATING EFFICIENCY**

Water can be heated by burning natural gas for direct heating or by using natural gas to make electricity to heat a resistance element, as shown in Figure 9.5. In each case the end result is enough heat to warm 50 gallons of water from 45°F to 160°F. Electrical heating consumes substantially more gas even though the efficiency of the electric heater is nearly 100 percent. The amount of energy needed to raise the temperature of water from 45°F to 160°F is 48,000 Btu. The 48,000 Btu input to the electric heater requires 150,000 Btu in the form of natural gas into the electric power plant. Delivering natural gas directly to the water heater consumes only 77,000 Btu of energy.

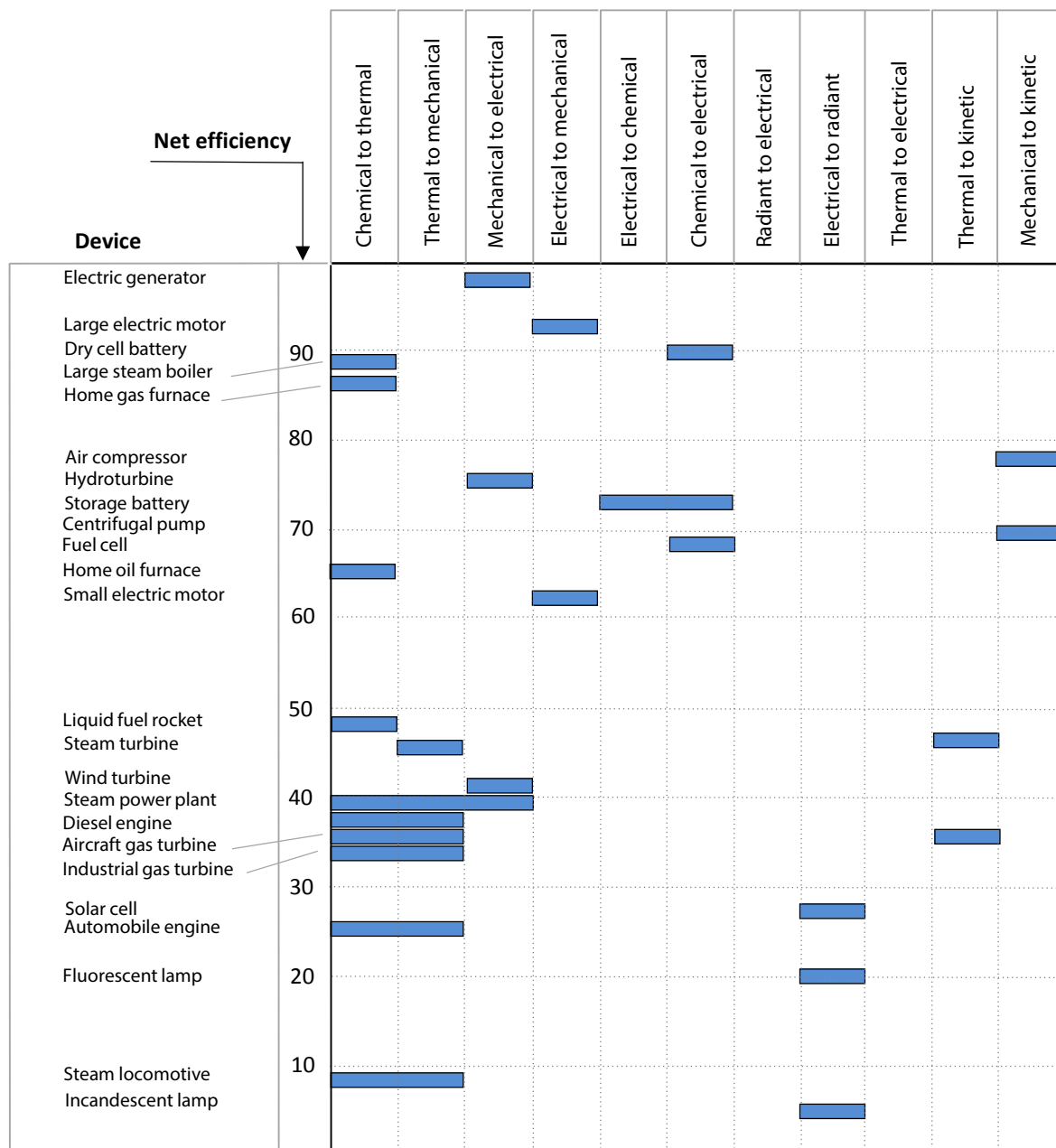


**Figure 9.5** Two methods of heating water.

### 9.6 Energy Conversion Efficiency

Energy can be converted from one form to another, for example the chemical energy in natural gas can be converted to thermal energy to make steam, which can be converted to mechanical energy in a turbine-generator to make electrical energy. Each conversion degrades some energy to a form that is not useful. We say that this energy is 'lost' or 'wasted'. (It is not lost. It still exists, but in some other form.)

Figure 9.6 shows the energy conversion efficiencies of a variety of devices. New technologies, such as wind turbines, photovoltaic solar cells, etc., will become more efficient in the future.



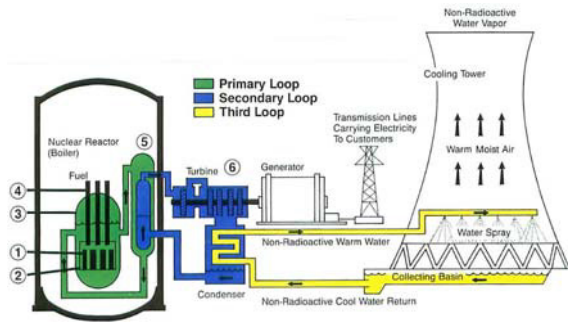
**Figure 9.6** Efficiency of energy conversion runs from less than 10 percent to 99 percent for large generators. The efficiency of each device has a wider range than shown in the graph, which is useful to rank the devices and not to precisely evaluate their performance.



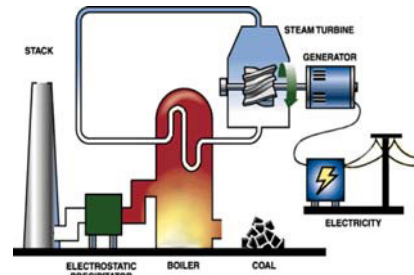
Hydro-turbine



Gas turbine (courtesy of Siemens)



Nuclear power plant



Coal-fired steam power plant

**Figure 9.7** Four traditional methods of converting energy into electricity:  
Hydro-turbine, Gas turbine, Nuclear energy, Fossil fuel combustion.

Figure 9.7 shows the four traditional methods of producing electricity. A hydro-turbine converts about 75 percent of the potential energy of the passing water into electricity.

A fossil fuel plant converts only 35–40% percent of the heat generated by burning fossil fuel into electrical energy. The conversion of chemical energy in coal to thermal energy in a large boiler is 88% efficient; the conversion of thermal energy into mechanical energy in a steam plant is about 45% efficient, and the conversion of mechanical energy into electricity by a generator is 98% efficient. The complete conversion of chemical energy to electric energy has an efficiency of  $(0.88)(0.45)(0.98) = 0.388$ , or 39%. About two-thirds of the chemical energy stored in the coal is released to the environment, primarily as hot gases and cooling water. The laws of thermodynamics indicate that it is impossible to do much better than this.

A nuclear plant makes steam by controlled fission of Uranium 235. In nuclear reactors, an extra layer of protection against leaks is provided by the heat exchanger between the reactor and the steam-driven turbine. The cooling water for steam condensation does not contact the cooling fluid that has passed through the reactor.



## 9.7 Renewable Energy

### 9.7.1 Wind Energy

A wind turbine, Figure 9.8, operates 75–80% of the time and converts about 30% of the kinetic energy of wind to electric energy. The wind-driven rotor drives an electric generator. The available wind power is much greater than the rated efficiency of the wind turbine for several reasons. The velocity of the wind leaving the rotor cannot be zero so it is impossible to extract all of the wind energy. According to Betz's Law no turbine can capture more than 59.3% of the kinetic wind energy. This could be achieved only with an ideal propeller operating at a very high rotor tip speed.

If the incoming air has 100 units of energy (kinetic energy), about 40 units will be transferred into mechanical energy by the rotor blades. Friction in the brake and gearbox reduces the mechanical energy delivered to the generator to 35 units. The electrical output from the generator will be about 33 units and the final output is about 30 units, due to energy loss in voltage conversion and distribution.



www.sylvania.com

We do not reinvent  
the wheel we reinvent  
light.

Fascinating lighting offers an infinite spectrum of possibilities: Innovative technologies and new markets provide both opportunities and challenges. An environment in which your expertise is in high demand. Enjoy the supportive working atmosphere within our global group and benefit from international career paths. Implement sustainable ideas in close cooperation with other specialists and contribute to influencing our future. Come and join us in reinventing light every day.

Light is OSRAM

OSRAM  
SYLVANIA





Figure 9.8 Installation of wind turbines

**Example 9.6 WIND ENERGY TO ELECTRICAL ENERGY**

As of January, 2013, the world's largest wind turbine, built by Vestas, has a rotor diameter of 164 m and a rated capacity of 10 MW (Wikipedia). Calculate the power for a wind velocity of 14 m/s and an air density of  $\rho = 1.2 \text{ kg/m}^3$ .

The rotor swept area is

$$A = \pi D^2/4 = \pi(164 \text{ m})^2/4 = 21,124 \text{ m}^2$$

The wind power is calculated using

$$P = 0.5 \rho AV^3$$

$$P = 0.5(1.2 \text{ kg/m}^3)(21,124 \text{ m}^2)(14 \text{ m/s})^3 = 34.8 \text{ MW}$$

The turbine can deliver about 30-35% of this total wind power as electricity, hence the rated capacity of 10 MW.

### 9.7.2 Solar Energy

Insolation is the rate of solar energy arriving on a specific flat surface perpendicular to the line of the sun. The average rate of solar energy arriving at the outer edge of the earth's atmosphere, before any losses is  $1.366 \text{ kW/m}^2$  ( $429 \text{ Btu/h-ft}^2$ ). At sea level, the least possible loss is 29 to 30 percent. The maximum possible insolation is therefore about 70% of the incident value, or  $0.956 \text{ kW/m}^2$  ( $320 \text{ Btu/ft}^2\text{-h}$ ). An actual solar collector will deliver a fraction of this, say 10–30%, depending on the technology used, the geographic location of the collector, and local conditions such as shade and snow cover.

Solar heating of water is relatively simple. A solar absorber, usually a flat black surface with high absorbance, receives the radiant energy from the sun and converts it to heat. Water is warmed as it passes through the absorber.

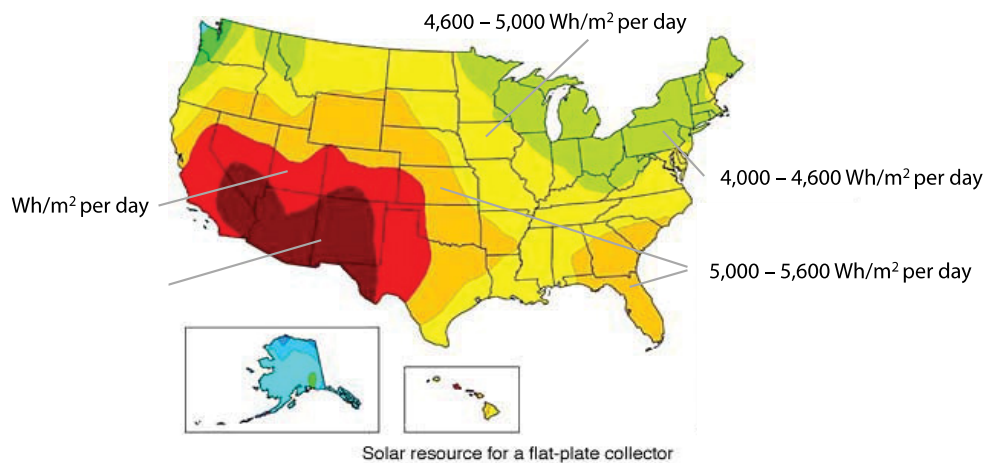
Solar electric or photovoltaic cells convert sunlight directly into electricity. A 1 kW solar electric system will generate one kilowatt hour (1 kWh) of electricity after exposure to one hour of sunlight. In Wisconsin, an unshaded 1-kW panel, facing south and inclined between  $25^\circ$  and  $50^\circ$ , will generate about 1,200 kW per year. A 1-kW pole-mounted tracking panel that constantly faces the sun will generate about 1,600 kWh/yr.

**Example 9.7 PHOTOVOLTAIC CONVERSION OF SOLAR ENERGY TO ELECTRICAL ENERGY**

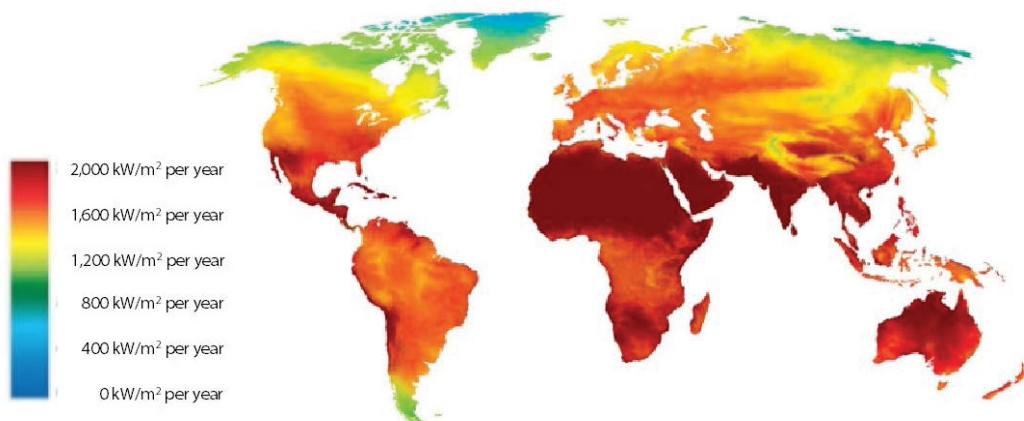
Solar electric power will be installed in house that receives an average of 4 hours of sun per day to provide an output of 1,500 Watt-h/day (Wh/d). The wattage output is 80% of the collected solar energy, so the collection requirement is  $1,500/0.8 = 1,825$  Wh/d. Divide the daily power requirement by the average of 4 h/d of sun to get the required system output of  $(1,825 \text{ Wh})/(4 \text{ h}) = 470 \text{ W}$  (rounded up). The proposed installation is four 120 W panels or eight 60 W panels.

The Watt-peak (Wp) or kilowatt peak (kWp) is a standardized measure that excludes solar conditions. This must be translated into a kWh value that takes account of the solar conditions at the particular location of the solar collector. As a rough idea, a 1 kWp system will produce 1,800 kWh/year in Southern California and 850 kWh/year in Northern Germany. The average Wisconsin home consumes 8,500 kWh of electricity per year, which would require a 10 kWp system.

The map in Figure 9.9 shows the average watt-hours per square meter per day ( $\text{Wh/m}^2\text{-d}$ ) available to a flat-plate solar collector in the United States. Figure 9.10 shows a NASA map of world solar energy potential (incident solar radiation or insolation), with units of  $\text{kW/m}^2\text{-year}$ .



**Figure 9.9** Map shows solar energy available on a flat-plate collector, measured in Watt-hours per square meter per day.



**Figure 9.10** Map of world solar energy potential (incident solar radiation or insolation), measured in  $\text{kW/m}^2$  per year. (Source: NASA)

## 9.8 Conclusion

This chapter has introduced the concept of the energy balance, the units commonly used to measure energy and power, the efficiency of converting energy from one form to another, and a few ways of producing electricity.

The law of conservation of energy is analogous to the law of conservation of mass. The energy balance is analogous to the material balance. Furthermore, making an energy balance requires knowledge of the material balance in order to account for energy carried with materials as they move through the system. Understanding the conservation of energy guides design decisions that are effective in energy conservation.



Discover the truth at [www.deloitte.ca/careers](http://www.deloitte.ca/careers)

**Deloitte.**

© Deloitte & Touche LLP and affiliated entities.



Click on the ad to read more

# 10 The Energy Balance and Enthalpy

## 10.1 The Design Problem

A method is needed to quantify the energy that is associated with the flow of a mass of material. Enthalpy is a measure of the amount of energy stored in material. This energy is stored in chemical bonds that hold a molecule together, by the internal forces that hold solids and liquids as a cohesive mass, by the random motion of molecules in a gas, and by other internal phenomena. The enthalpy changes during processing, as the temperature and form of material changes, and by computing the enthalpy change we can estimate the amount of energy consumed or generated.

Because Btu and °F are still widely used in the U.S., in contrast to the rest of the world, these units are used in some examples, while others will use metric units, and some examples will give both units. This should not confuse understanding of the underlying concepts and general methods for making the energy balance.

## 10.2 Enthalpy

In a simple batch operation in which a mass of material is being changed from state 1 to state 2, the difference between the heat energy added to the material, and the mechanical work done on the material, is

$$Q - W = mH_2 - mH_1$$

where  $Q$  = heat energy (kJ, Btu)

$W$  = mechanical work (kJ, Btu)

$m$  = mass of material (kg, lb)

$H_1$  and  $H_2$  = enthalpy of the material at states 1 and 2 (kJ/kg, Btu/lb)

The energy balance is

$$[\text{Total enthalpy in}] + [\text{Heat in}] = [\text{Total enthalpy out}] + [\text{Heat out}]$$

Each term must have the same units (e.g. kJ, Btu, or kWh).

The accounting for energy flow rates (kJ/m, kJ/h, Btu/h, or kW) is

$$\left[ \begin{array}{c} \text{Rate of} \\ \text{enthalpy in} \end{array} \right] + \left[ \begin{array}{c} \text{Rate of} \\ \text{heat in} \end{array} \right] = \left[ \begin{array}{c} \text{Rate of} \\ \text{enthalpy out} \end{array} \right] + \left[ \begin{array}{c} \text{Rate of} \\ \text{heat out} \end{array} \right]$$

where the units are kJ/min, kJ/h, BTU/h, or kW.

It is not correct to speak of the heat content of a substance because from the thermodynamic point of view it is heat only when it is being transferred. Something is needed which is a property of the material and this is enthalpy.

*Enthalpy* ( $H$ ) is a thermodynamic quantity that is used to describe the change in heat energy when a material changes from one temperature to another. It cannot be detected directly and it has no absolute value. Only changes in enthalpy can be measured, and the change is calculated relative to some initial condition or standard reference condition, with units of kJ/kg, kJ/g-mol, Btu/lb, or Btu/lb-mol.

Enthalpy increases or decreases depending on the direction of the temperature change. If the enthalpy of a substance is known at different temperatures it is simple to calculate the heat required to bring the substance from one condition to another.

The change in enthalpy is referenced to an arbitrarily chosen standard state or reference state. At the standard state the enthalpy is assumed to be zero. For gases, 25°C (77°F) and 1 atm pressure is commonly used as the standard state, and will be used here. For steam the standard state is liquid water at 0°C (32°F). Obviously the choice of a standard state affects the number assigned to the enthalpy, but it does not affect the change in enthalpy for a given process.

The enthalpy for liquids and solids depends on the temperature and mass of the material. The value of  $H$  for gases or vapor depends on pressure, temperature, and mass. This dependency (for gases) is a subject for a more advanced course.

### 10.3 Specific Heat

Sensible heat effects are changes in temperature that can be sensed, say, by the touch of the hand, and for this reason the energy involved with temperature change is called *sensible heat*.

The amount of sensible heat,  $Q$ , that must be added (or removed) to change mass  $m$  from temperature  $T_1$  to temperature  $T_2$  is

$$Q = c_p m (T_2 - T_1)$$

where  $c_p$  is the specific heat (or heat capacity) of the substance.

The *specific heat* of a substance is the amount of heat per unit mass required to raise its temperature by one degree. It is the basis of the definition of the Btu (British thermal unit) and the calorie. In the SI system of units, the calorie is rarely used, and has been largely replaced by the Joule.



- 1 Btu will raise the temperature of 1 lb of water by 1°F
- 1 calorie will raise the temperature of 1 g of water by 1°C
- 4.184 kJ will raise the temperature of 1 kg of water by 1°C.

Thus, the specific heat of water is 1 Btu/lb°F, 1 cal/g°C, or 4.184 kJ/kg°C:

Derived quantities that specify heat capacity as an *intensive* property (independent of the size of the sample) are the molar heat capacity (heat capacity of a mole of pure substance) and the specific heat, which is the heat capacity per unit mass of material. The *specific heat* is sometimes called the *heat capacity*,  $c_p$ , and is measured in units of J/g°C, kJ/kg°C, or Btu/lb°F.

When substances melt, evaporate, or change from one crystalline phase to another, there is a heat effect known as the *heat of fusion* or *heat of transition*. Sometimes this heat effect is called *latent heat* to distinguish it from *sensible heat*. Latent heat is that required to cause a change in state with no change in temperature.

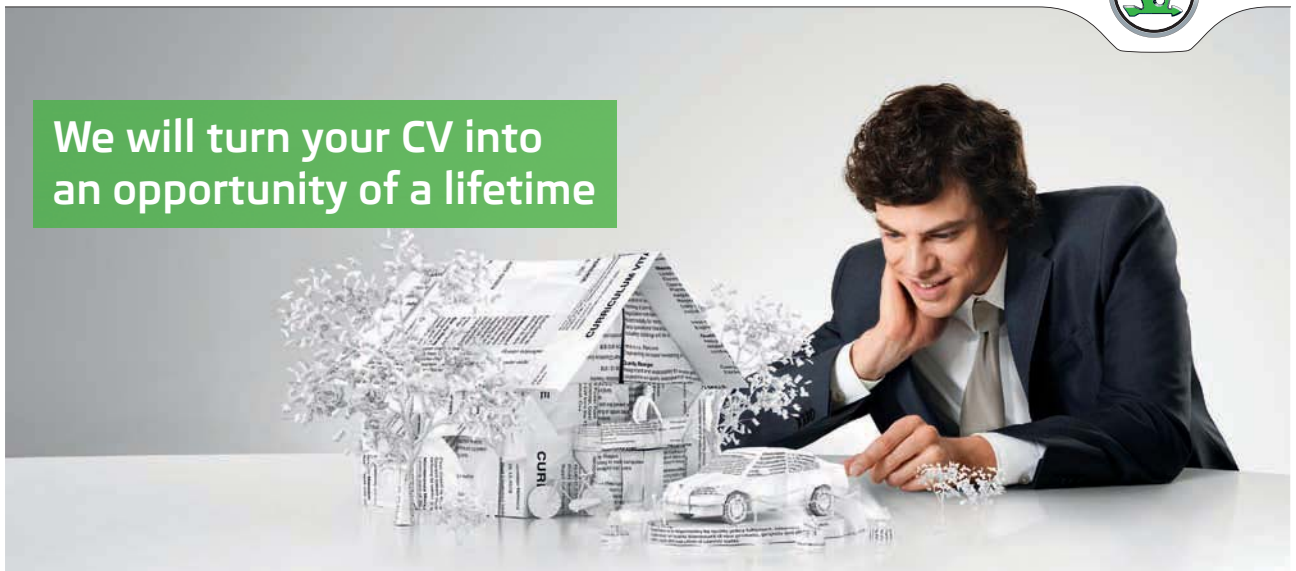
The heat effect when a substance changes from a solid to a liquid or from a liquid to a vapor is the *latent heat of fusion* or *latent heat of evaporation*. The latent heats of fusion and evaporation are always positive. For pure substances this heat effect takes place at constant temperature; with mixtures the temperature changes. In calculating the enthalpy of a substance, the latent heat must be added if there is a change of phase.

SIMPLY CLEVER

ŠKODA



We will turn your CV into  
an opportunity of a lifetime



Do you like cars? Would you like to be a part of a successful brand?  
We will appreciate and reward both your enthusiasm and talent.  
Send us your CV. You will be surprised where it can take you.

Send us your CV on  
[www.employerforlife.com](http://www.employerforlife.com)



Click on the ad to read more



For example, water at 100°C (212°F) can be changed to steam by adding 2,257 kJ/kg (970 Btu/lb) of water. If this is done at constant pressure, the temperature of the steam is 100°C. Adding an amount of heat equal to the heat of vaporization (2,257 kJ/kg or 970 Btu/lb) changes the liquid to vapor but does not change the temperature. Likewise, changing 100°C steam to 100°C water requires the removal of 2,257 kJ/kg (970 Btu/lb) of heat.

Because of the importance of steam for heating, its enthalpy has been calculated for various temperatures and pressures, based on liquid water at 0°C (32°F). Tables of the thermodynamic properties of steam list vapor pressure (usually absolute pressure), specific volume (ft<sup>3</sup>/lb or m<sup>3</sup>/kg) of liquid and vapor, enthalpy (Btu/lb or kJ/kg) of liquid and vapor, and entropy (Btu/lb°R or kJ/kg-K) of liquid and vapor. The boiling point of a liquid depends on the pressure. The heat of vaporization decreases as the pressure increases and therefore as the temperature increases. Appendix 5 gives some data for saturated water and steam.

Table 10.1 gives the specific heat of air, water vapor and some common gases at different temperatures. The heat capacity of gases varies with pressure, but only slightly with temperature. The specific heat of air is about 1.00 kJ/kg°C (0.24 Btu/lb°F) from 0°C–260°C (0°F–500°F). Several other gases, with the notable exception of hydrogen, have a similar value. Water vapor has a higher specific heat, about 1.88 kJ/kg°C (0.45 Btu/lb°F) over a wide range. All these values will increase if the gases are pressurized.

Table 10.2 gives the specific heat and heat of vaporization of selected liquids. The specific heat for liquid organic chemicals is about 0.5 Btu/lb°F (2.1 kJ/kg°C). Water is the exceptional liquid, with a much higher specific heat.

Temp (°F)	Air	H <sub>2</sub>	O <sub>2</sub>	N <sub>2</sub>	CO	CO <sub>2</sub>	H <sub>2</sub> O vapor
0	0.239	3.364	0.218	0.248	0.248	0.190	
32	0.240	3.390	0.218	0.248	0.248	0.195	
100	0.240	3.425	0.220	0.248	0.248	0.205	
250	0.242	3.455	0.224	0.249	0.250	0.222	0.454
500	0.247	3.469	0.234	0.254	0.256	0.247	0.457
Conversion Factor: 1 Btu/lb°F = 4.187 kJ/kg							

**Table 10.1** Specific heats (Btu/lb°F) of gases at constant pressure (1 atm) for various temperatures.  
Source: National Bureau of Standards Circular 461C (1947), p. 298.

Substance	Specific heat, $c_p$		Boiling point		Heat of vaporization	
	Btu/lb°F	kJ/kg°C	°C	°F	Btu/lb	kJ/kg
Acetic acid	0.522	2.186				
Acetone	0.514	2.152	56.2	133.2	224.0	521
Benzene	0.419	1.754	80.1	176.2	169.5	394.3
n-Butanol	0.582	2.437	116.8	242.2	254.4	591.7
Carbon tetrachloride	0.201	0.842	76.8	170.2	83.6	194.5
Ethyl alcohol	0.68	2.85	78.3	172.9	367.8	855.5
Toluene	0.44	1.84	110.6	231.1	156.3	363.6
Water	1.00	4.187	100	212	970.3	2,257

Conversions: 1 Btu/lb°F = 4.187 kJ/kg°C ; 1 Btu/lb = 2.326 kJ/kg

**Table 10.2** Specific heat and heat of vaporization for some liquids

### Example 10.1 MAKING STEAM

Five thousand pounds per hour of water at 100°F is heated to make steam at 212°F and 1 atmosphere pressure. The amount of heat required will be calculated in two ways.

*Method 1. Use the specific heat (1 Btu/lb-°F) and the latent heat of vaporization (970 Btu/lb)*

Basis:  $m = 5,000$  lb

- Heating the water from 100°F to 212°F requires  
 $Q = mc_p(T_2 - T_1) = (5000 \text{ lb/h})(1 \text{ Btu/lb}^\circ\text{F})(212^\circ\text{F} - 100^\circ\text{F}) = 560,000 \text{ Btu/h}$
- Changing the 212°F water to 212°F steam requires  
 $Q = mH_v = (5000 \text{ lb/h})(970 \text{ Btu/lb}) = 4,850,000 \text{ Btu/h}$
- The total heat required is  
 $560,000 + 4,850,000 = 5,410,000 \text{ Btu/h}$

*Method 2. Use enthalpy.*

The amount of heat required is equal to the change in enthalpy of the incoming water and the exiting steam.

From Appendix 5

Enthalpy of liquid water at 100°F and 1 atm  $H_1 = 67.97 \text{ Btu/lb}$   
 Enthalpy of water vapor (steam) at 212°F and 1 atm  $H_2 = 1,150.4 \text{ Btu/lb}$

- Change in enthalpy and the total amount of heat required to make the steam  
 $Q = m(H_2 - H_1) = (5000 \text{ lb/h})(1,150.4 \text{ Btu/lb} - 67.97 \text{ Btu/lb}) = 5,412,000 \text{ Btu/h}$

This answer is slightly different than the 5,410,000 Btu/h calculated by Method 1 because the enthalpy values from the steam tables are more precise than we calculate using a specific heat of 1.00 Btu/lb°F and a latent heat of 970 Btu/lb. The difference is not important in our understanding of the basic principles of making an energy balance.

**Example 10.2 ENTHALPY OF HUMID AIR**

Calculate the enthalpy of moist air at 100% and 50% relative humidity (RH).

Air saturated with water vapor air at 25°C, has a mass fraction water vapor of  $x = 0.0203$  kg H<sub>2</sub>O/kg air. The enthalpy of dry air at  $T = 0^\circ\text{C}$  is 0.0 kJ/kg.

$H$  for saturated air at 25°C

$$H_{Sat,25^\circ\text{C}} = c_{p,air}\Delta T + x(c_{p,air}\Delta T + H_{water,25^\circ\text{C}})$$

$$H_{Sat,25^\circ\text{C}} = \left(1.006 \frac{\text{kJ}}{\text{kg } ^\circ\text{C}}\right)(25^\circ\text{C}) + \left(0.0203 \frac{\text{kg H}_2\text{O}}{\text{kg air}}\right) \left[ \left(1.84 \frac{\text{kJ}}{\text{kg } ^\circ\text{C}}\right)(25^\circ\text{C}) + 2,442 \frac{\text{kJ}}{\text{kg}} \right]$$

$$= 25.15 + 0.93 + 49.57 = 75.65 \frac{\text{kJ}}{\text{kg}}$$

The first term in the brackets is the sensible heat due to heating water vapor, and is often neglected.

At 50% RH,  $x = 0.01$  kg H<sub>2</sub>O/kg air, and the enthalpy is

$$H_{RH=50\%,25^\circ\text{C}} = \left(1.006 \frac{\text{kJ}}{\text{kg } ^\circ\text{C}}\right)(25^\circ\text{C}) + \left(0.01 \frac{\text{kg H}_2\text{O}}{\text{kg air}}\right) \left[ \left(1.84 \frac{\text{kJ}}{\text{kg } ^\circ\text{C}}\right)(25^\circ\text{C}) + 2,442 \frac{\text{kJ}}{\text{kg}} \right]$$

$$= 25.15 + 0.46 + 24.42 = 50.03 \frac{\text{kJ}}{\text{kg}}$$

**Example 10.3 SPECIFIC HEAT OF AIR**

The specific heat of air at ambient conditions is 0.240 Btu/lb°F (4.187 kJ/kg). This can be calculated from the specific heats of the three principal components of air, i.e. nitrogen, oxygen and argon.

	<b>Nitrogen</b>	<b>Oxygen</b>	<b>Argon</b>
Specific heats (Btu/lb°F)	0.249	0.218	0.124
Volume fraction	0.7808	0.2095	0.0093
Molar mass	28	32	40
Mass	21.86	6.704	0.372
Total mass = 21.86 + 6.704 + 0.372 = 28.94			
Mass Fractions	0.755	0.232	0.013
Notes: Mass fraction = mass of element/total mass Example: Nitrogen 21.86/28.94 = 0.755			

Specific heat of mixture

$$0.755(0.249) + 0.232(0.218) + 0.013(0.124) = 0.1880 + 0.05088 + 0.0016 = 0.240 \text{ Btu/lb}^\circ\text{F}.$$

**Example 10.4 HEAT RECOVERY**

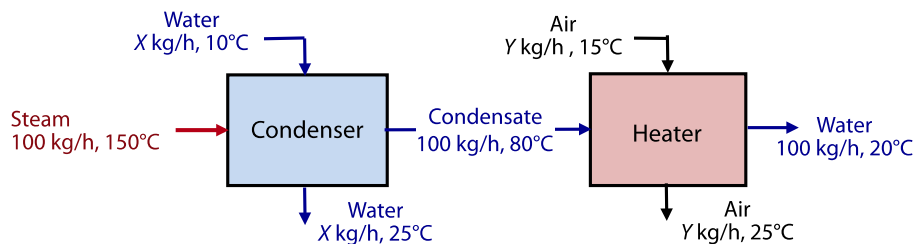
Steam that has been used in a process or a boiler is condensed and the condensate is used to heat air. The arrangement shown in Figure 10.1

The cooling water entering the condenser is 10°C. The steam entering the condenser is at 150°C. The system is designed to have 25°C cooling water leave the condenser. The condensate enters the heater at 80°C and leaves at 20°C. Calculate the amount of cooling water,  $X$ , that is needed and the amount of air,  $Y$ , that can be heated.

There are two unknowns so two energy balance equations are needed. The possibilities are

1. energy balances on the condenser and on the heater
2. overall energy balance plus an energy balance on the condenser
3. overall energy balance plus an energy balance on the heater.

Ignore any loss of heat from the walls of the condenser, air heater, or piping.



**Figure 10.1** Heating air with heat recovered from a steam condenser.

The enthalpies of water and steam are found in Appendix 5.

Water at 10°C	$H = 42.02 \text{ kJ/kg}$
Water at 20°C	$H = 83.92 \text{ kJ/kg}$
Water at 25°C	$H = 104.84 \text{ kJ/kg}$
Water at 80°C	$H = 334.95 \text{ kJ/kg}$
Steam at 150°C	$H = 2745.9 \text{ kJ/kg}$

The heat capacity of air, from Table 10.1, is  $c_p = 0.24 \text{ Btu/lb}^\circ\text{F} = 1.005 \text{ kJ/kg}^\circ\text{C}$

Energy balance on the condenser will give the cooling water flow rate,  $X$

$$\begin{aligned} \text{Enthalpy absorbed by water} &= \text{enthalpy given up from steam} \\ (X \text{ kg/h})(104.84 \text{ kJ/kg} - 42.02 \text{ kJ/kg}) &= (100 \text{ kg/h})(2745.9 \text{ kJ/kg} - 334.95 \text{ kJ/kg}) \\ X &= (100 \text{ kg/h})(2411 \text{ kJ/h}) / (62.82 \text{ kJ/h}) = 3,838 \text{ kg/h water} \end{aligned}$$

Energy balance on the heater will give the air flow rate,  $Y$ .

$$\begin{aligned} \text{Enthalpy absorbed by air} &= \text{enthalpy given up from condensate} \\ (1.005 \text{ kJ/kg}^\circ\text{C})(Y \text{ kg/h})(25^\circ\text{C} - 15^\circ\text{C}) &= (100 \text{ kg/h})(334.95 \text{ kJ/kg} - 83.92 \text{ kJ/kg}) \\ Y &= (25,103 \text{ kJ/h}) / 10.05 \text{ kJ/kg} = 2,498 \text{ kg/h air} \end{aligned}$$

**Example 10.5 CONDENSING ETHANOL**

A flow of 1000 kg/h of Ethyl alcohol (ethanol) vapor at 78.3°C is to be condensed and cooled to 20°C. The boiling point of ethanol is 78.3°C so the vapor does not need additional cooling before condensation will occur. The latent heat of vaporization is 855.5 kJ/kg and this is the amount of heat that must be removed to accomplish the phase change from vapor to liquid. The specific heat of liquid ethanol is  $c_p = 2.85$  kJ/kg°C. Cooling water is available at 10°C.

Energy balance on ethanol:

$$(1000 \text{ kg/h})(2.85 \text{ kJ/kg } ^\circ\text{C})(78.3^\circ\text{C} - 20^\circ\text{C}) + (1000 \text{ kg/h})(855.5 \text{ kJ/kg}) = 166,155 \text{ kJ/h}$$

Energy balance on water, assuming the water is heated to 65°C.  $\Delta T$  is 65 – 10 = 55°C

$$(X \text{ kg/h})(65 - 10^\circ\text{C})(4.187 \text{ kJ/kg } ^\circ\text{C}) = 166.155 \text{ kJ/h}$$

$$X = (166.155 \text{ kJ/h}) / (65^\circ\text{C} - 10^\circ\text{C})(4.187 \text{ kJ/kg}) = 722 \text{ kg/h}$$

**Example 10.6 POWER PLANT COOLING WATER**

Consider the thermal electric power plant of Example 9.3. The plant discharges waste heat to cooling water that is used to condense the steam so it can be returned to the boiler after passing through the turbine. Calculate the amount of cooling water required for a once through cooling system if the increase in cooling water temperature is 15°C.

From Figure 9.4, the waste heat that the cooling water must dissipate is  $4.11 \times 10^6$  kWh. The mass of cooling water required to achieve this is

$$m = \frac{Q}{c_p \Delta T} = \frac{4.11 \times 10^6 \text{ kWh}}{(4.185 \text{ kJ/kg}^\circ\text{C})(15^\circ\text{C})} \times \frac{3.6 \times 10^3 \text{ kJ}}{\text{kWh}} = 2.36 \times 10^8 \text{ kg}$$

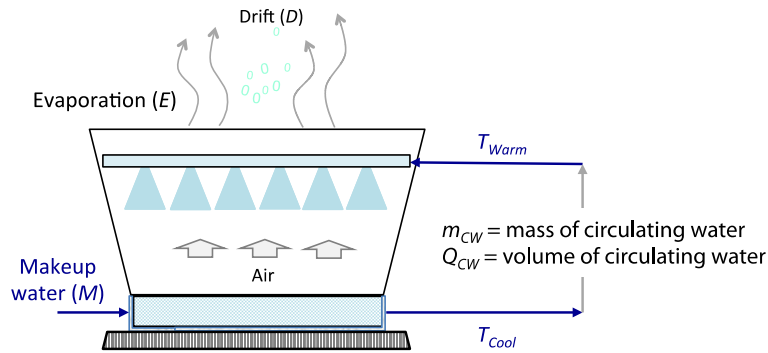
$$= (2.36 \times 10^8 \text{ kg}) \left( \frac{\text{m}^3}{1000 \text{ kg}} \right) = 2.36 \times 10^5 \text{ m}^3$$

This volume of water (62.3 million gallons) would meet the daily water demand of a city of about 400,000 people, assuming 600 L/cap-day (150 gal/cap-d). A much smaller flow of water would be used in a recirculating cooling system.

## 10.4 Cooling Tower Energy Balance

The material balance around a wet, evaporative cooling tower system in Figure 8.2 and Section 8.3 explained how the evaporation that cools the recirculating water causes the salt content to increase with each cycle of use. This section uses an energy balance on the cooling tower to explain how the recirculating water is cooled by the evaporation. Figure 10.2 defines the variables.

Warm water, at temperature  $T_{\text{Warm}}$ , is returned to the top of the cooling tower. An amount of water,  $E$ , evaporates as it falls or trickles down through the tower. The heat required to evaporate the water is derived from the water itself, which is cooled to the original water temperature,  $T_{\text{Cool}}$  and the water is once again ready for cooling service.



**Figure 10.2** The water balance for a fan-induced draft counter-flow cooling tower circuit.  $M = BD + E + D$

*Dry-bulb temperature* ( $T_{DB}$ ) is the property of air that is most commonly used. When people refer to the air temperature, they are normally referring to its dry-bulb temperature. The *wet-bulb temperature* ( $T_{WB}$ ) is the lowest temperature that can be reached by evaporation of water only. Cooling towers can achieve water temperatures below the *dry bulb temperature* of the cooling air.

I joined MITAS because  
I wanted **real responsibility**

The Graduate Programme  
for Engineers and Geoscientists  
[www.discovermitas.com](http://www.discovermitas.com)



**Month 16**  
I was a construction  
supervisor in  
the North Sea  
advising and  
helping foremen  
solve problems

Real work  
International opportunities  
Three work placements







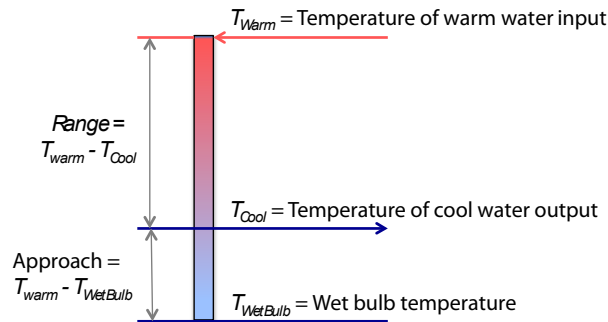


Figure 10.3 Definition of Range and Approach of a cooling tower.

Cooling towers are rated in terms of *range* and *approach*, as shown in Figure 10.3. The *range* is the temperature difference of the warm water entering the cooling tower and the cool water that is leaving. The *approach* is the difference in temperature between the cooled-water temperature and the entering-air *wet bulb temperature*. It is impossible for the cooled water temperature to be less than the wet bulb temperature and uneconomical to approach it too closely.

$$\text{Range} = T_{Warm} - T_{Cool}$$

$$\text{Approach} = T_{Cool} - T_{WB}$$

where  $T_{Warm}$  = inlet temperature of water to the tower ( $^{\circ}\text{C}$ ,  $^{\circ}\text{F}$ )

$T_{Cool}$  = outlet temperature of water from the tower ( $^{\circ}\text{C}$ ,  $^{\circ}\text{F}$ )

$T_{WB}$  = wet bulb temperature of entering air ( $^{\circ}\text{C}$ ,  $^{\circ}\text{F}$ )

The *range* is normally  $6^{\circ}\text{C}$  to  $16^{\circ}\text{C}$  (approx.  $10\text{--}30^{\circ}\text{F}$ ).

The approach is a good indicator of cooling tower performance. The lower the approach, the better the cooling tower performance. A larger cooling tower (that is, more air or more fill) will produce a closer approach (colder outlet water) for a given heat load, flow rate and entering air condition. The lower the wet-bulb temperature, which indicates either cool air, low humidity or a combination of the two, the lower the cooling tower can cool the water.

The cooling tower efficiency,  $\eta_{CT}$ , is defined by the temperatures shown in Figure 10.3 and is usually 70–75%.

$$\eta_{CT} = \frac{100(T_{Warm} - T_{Cool})}{T_{Warm} - T_{WB}} = \frac{100(\text{Range})}{T_{Warm} - T_{WB}}$$

Cooling tower *effectiveness* is quantified by the ratio of the actual range to the ideal range, that is, the difference between cooling water inlet temperature and ambient wet-bulb temperature. It is defined in terms of percentage.

$$\text{Effectiveness (\%)} = 100 \left( \frac{\text{Range}}{\text{Range} + \text{Approach}} \right) = 100 \left( \frac{T_{Warm} - T_{Cool}}{T_{Cool} - T_{WB}} \right)$$



The *cooling capacity* of a tower is the heat rejected in kJ/h or Btu/h.

$$\text{Cooling capacity} = m_{CW} c_p (T_{Warm} - T_{Cool})$$

where  $m_{CW}$  = mass flow rate of water (kg/h, lb/h)  
 $c_p$  = specific heat of water (kJ/kg °C, Btu/lb °F)  
 $T_{Warm}$  = inlet temperature of water to the tower (°C, °F)  
 $T_{Cool}$  = outlet temperature of water from the tower (°C, °F)

Air conditioning and refrigeration equipment capacity in the U.S. and much of North America is often specified in “tons” of refrigeration. Many manufacturers also specify Btu/h, especially for smaller equipment.

A ton of refrigeration (commonly abbreviated as *TR*) is a unit of power that describes the heat extraction capacity of cooling equipment. It is equivalent to the consumption of one ton (2000 lb) of ice per day and originated during the transition from stored natural ice to mechanical refrigeration. More precisely, it is the heat of fusion (144 Btu/lb or 333kJ/kg) absorbed by melting 1 ton (2,000 lb or 907 kg) of pure ice per day at 0°C (32°F). A ton of cooling is the removal of 12,000 Btu/h (3,517 W = 12,660 kJ/h = 12.66 MJ/h) from water.

$$TR = mH_f = (2000 \text{ lb/day of ice})(144 \text{ Btu/lb})(\text{d}/24\text{h}) = 12,000 \text{ Btu/h}$$

where  $H_f$  = heat of fusion

A mechanical chiller adds approximately 3,000 Btu/h (879 W or 3.165 MJ/h) of parasitic heat load. Therefore, a ton of cooling in a cooling tower is the removal of 15,000 Btu/h (4,396 W or 15.83 MJ/h). An absorption chiller generates 18,000 Btu of heat for each ton of chilled water produced. Thus a cooling tower for an absorption chiller must remove 30,000 Btu/h (8,792 W or 31.65 MJ/h).

From a simplified heat balance around the cooling tower, the energy required for evaporation must equal the energy supplied from cooling the circulating stream (as shown in Figure 10.2):

$$EH_v = m_{CW} c_p \Delta T \text{ or } E = m_{CW} c_p \Delta T / H_v$$

where  $E$  = evaporation rate (lb/h or kg/h)  
 $m_{CW}$  = mass flow rate of circulating water (lb/h or kg/h)  
 $H_v$  = latent heat of vaporization of water (970 Btu/lb or 2260 kJ/kg)  
 $\Delta T$  = water temperature difference from tower top to tower bottom (°F or °C)  
 $c_p$  = specific heat of water (1 Btu/lb°F or 4.184 kJ/kg°C)

*Rule-of-thumb 1.* One ton of cooling means that 15,000 Btu/h of heat must be removed from the water, and for a  $\Delta T = 10^\circ\text{F}$ , that requires a 3 gal/min flow of water (1 gal water = 8.34 lb).

$$15,000 \text{ Btu/h} = m_{CW} c_p \Delta T = m_{CW} (1 \text{ Btu/lb-}^\circ\text{F})(10^\circ\text{F})$$

$$m_{CW} = (15,000 \text{ Btu/h}) / (10 \text{ Btu/lb}) = 1,500 \text{ lb/h} = 25 \text{ lb/min} = 3 \text{ gal/min}$$

*Rule of thumb 2.* Removing 15,000 Btu/h requires evaporating 1.85 gal/h. Evaporation of 1 lb of water takes about 970 Btu of heat.

$$15,000 \text{ Btu/h} = (E) H_v = (E) (970 \text{ Btu/lb})$$

$$E = (15,000 \text{ Btu/h}) / (970 \text{ Btu/lb}) = 15.5 \text{ lb/h} = 1.85 \text{ gal/h}$$

Operating an absorption chiller requires the removal of twice the amount of heat and twice the amount of water must be evaporated.

### 10.5 Boiler Efficiency and Water Use

Water absorbs more heat for a given temperature rise than any other common inorganic substance. It expands 1600 times as it evaporates to form steam at atmospheric pressure. The steam is capable of carrying large quantities of heat. These unique properties of water, and its ready availability, make it an ideal raw material for heating and power generating processes.

**ie business school**

#1 EUROPEAN BUSINESS SCHOOL  
FINANCIAL TIMES 2013

**#gobeyond**

**MASTER IN MANAGEMENT**

**Because achieving your dreams is your greatest challenge.** IE Business School's Master in Management taught in English, Spanish or bilingually, trains young high performance professionals at the beginning of their career through an innovative and stimulating program that will help them reach their full potential.

- Choose your area of specialization.
- Customize your master through the different options offered.
- Global Immersion Weeks in locations such as London, Silicon Valley or Shanghai.

*Because you change, we change with you.*

www.ie.edu/master-management | mim.admissions@ie.edu | Facebook | Twitter | LinkedIn | YouTube | Instagram



The power output of a boiler, ignoring adjustment for steam pressure, is

$$BHP = \frac{S \times F_E}{34.5}$$

where  $BHP$  = boiler horsepower (hp)

$S$  = Steam production (lb/h)

$$F_E = \frac{H_{SH} + H_v}{970.3} = \text{factor of evaporation}$$

$H_{SH}$  = sensible heat (Btu/lb)

$H_v$  = latent heat of evaporation of water (970.3 Btu/lb at 212°F and 1 atm).

34.5 = conversion factor (1  $BHP$  = 34.5 lb/h steam, at 212°F and 1 atm)

The boiler fuel consumption depends on the feedwater temperature, steam temperature and pressure, boiler efficiency, and the fuel heating value.

$$F = \frac{S(H_S - H_{FW})}{\eta_{boiler} F_{HV}}$$

where  $F$  = fuel consumption (gal)

$S$  = steam production (lb/h)

$H_S$  = enthalpy of steam @ stated temperature and pressure (Btu/lb)

$H_{FW}$  = enthalpy of feedwater @ saturation temperature (Btu/lb)

$\eta_{boiler}$  = boiler efficiency (typically 80%)

$F_{HV}$  = fuel heating value (Btu/gal)

#### Example 10.7 BOILER HORSEPOWER

A boiler generating 21,500 lb/h of steam at 155 lb/in<sup>2</sup> has a factor of evaporation of  $F_E = 1.02$ . The boiler horsepower is

$$BHP = \frac{(21,500 \text{ lb/hr})(1.02)}{34.5} = 636 \text{ hp}$$

#### Example 10.8 FACTOR OF EVAPORATION

Water enters a boiler at 225°F. The boiler pressure is 100 lb/in<sup>2</sup> and the boiler water temperature is 338°F. The latent heat is 881 Btu/lb. The factor of evaporation is

$$F_E = \frac{H_{SH} + H_{LH}}{970.3} = \frac{(338^\circ\text{F} - 225^\circ\text{F})(1 \text{ Btu/lb}^\circ\text{F}) + 881 \text{ Btu/lb}}{970.3 \text{ Btu/lb}} = 1.02$$

**Example 10.9 BOILER FUEL CONSUMPTION**

A boiler produces 10,000 lb/h of steam using diesel fuel ( $F_{HV} = 130,000$  Btu/gal) with a feedwater temperature of 154°F. The enthalpy of the steam is 1190 Btu/lb at 100 lb/in<sup>2</sup>.

$$F = \frac{S(H_S - H_{FW})}{\eta_{boiler} F_{HV}} = \frac{(10,000 \text{ lb/h})(1,190 - 122 \text{ Btu/lb})}{0.8(130,000 \text{ Btu/gal})} = 103 \text{ gal/h}$$

All natural waters contain varying amounts of dissolved and suspended matter and dissolved gases the amount of minerals dissolved in water varies from 30 g/L in sea water to anything from 50 mg/L to 1500 mg/L in fresh water supplies. Since water impurities cause boiler problems, careful consideration must be given to the quality of the water used for generating steam. Table 10.3 gives the American Society of Mechanical Engineers (ASME) guidelines for water quality in modern industrial water tube boilers for reliable continuous operation.

The boiler feed water must be of such quality that it can be concentrated a reasonable number of times inside the boiler, without exceeding the tolerance limits of the particular boiler design. If the feed water does not meet these requirements it must be treated to remove impurities. The impurities need not be completely removed in all cases, however, since chemical treatment inside the boiler can effectively and economically counteract them.



**no.1**  
nine years  
in a row

## STUDY AT A TOP RANKED INTERNATIONAL BUSINESS SCHOOL

Reach your full potential at the Stockholm School of Economics, in one of the most innovative cities in the world. The School is ranked by the Financial Times as the number one business school in the Nordic and Baltic countries.

Visit us at [www.hhs.se](http://www.hhs.se)





Drum pressure (psi)	Iron (ppm Fe)	Copper (ppm Cu)	Total hardness (ppm CaCO <sub>3</sub> )	Silica (ppm SiO <sub>2</sub> )	Total alkalinity (ppm CaCO <sub>3</sub> )	TDS (mg/L)
0-300	0.100	0.050	0.300	150	149-700	700-3500
301-450	0.050	0.025	0.300	90	120-600	600-3000
451-600	0.030	0.020	0.200	40	100-500	500-2500
601-750	0.025	0.020	0.200	30	40-200	200-1000
751-900	0.020	0.015	0.100	20	30-150	150-750
901-1000	0.020	0.015	0.050	8	25-125	125-625
1001-1800	0.010	0.010	0.0	2	100	100
1800-2350	0.010	0.010	0.0	1	50	100

Source: American Society of Mechanical Engineers (ASME)

**Table 10.3** Guidelines for water quality in modern industrial water tube boilers for reliable continuous operation.

Boiler blowdown is the intentional removal of boiler water to control the level of total dissolved solids (TDS) in the boiler during the steam production. The blowdown material balance was covered in an example in Chapter 8.

The blowdown rate of a boiler depends on

- 1) steam consumption (steam used in the process and not returned as condensate to the boiler)
- 2) concentration of impurities in the feed water, and
- 3) maximum allowable TDS in the boiler.

From the view of the boiler, feed water enters, steam and blowdown exit. The boiler adds fuel energy to the steam and blowdown that exit the boiler. Blowdown is expressed as a fraction of feedwater mass flow and can range from less than 1% to more than 10% depending on water chemistry, boiler operating pressure, and other factors. However, a 10% blowdown rate does not mean 10% energy loss because it is moderate-energy water and not high-energy steam. The energy added to the blowdown stream is blowdown flow rate times the difference in the enthalpy of the blowdown and the feedwater. Therefore, 10% blowdown rate can translate into 5% fuel energy input.

The fraction of energy loss associated with blowdown,  $L_{BD}$ , is the heat energy lost divided by the fuel energy put into the boiler.

$$L_{BD} = \frac{m_{BD}(H_{BD} - H_{FW})}{m_{Fuel}(HHV)}$$

where  $L_{BD}$  = loss due to blowdown (%)

$m_{BD}$  = mass flowrate of blowdown (lb/h)

$m_{Fuel}$  = mass flow rate of fuel (lb/h)



$H_{BD}$  = enthalpy of blowdown (Btu/lb)

$H_{FW}$  = enthalpy of feedwater at saturation temperature (Btu/lb)

$HHV$  = higher heating value of fuel (Btu/lb)

## 10.6 Conclusion

The law of conservation of energy is analogous to the law of conservation of mass. The energy balance is analogous to the material balance. Furthermore, making an energy balance requires knowledge of the material balance in order to account for energy carried with materials as they move through the system.

*Enthalpy*,  $H$ , is a thermodynamic quantity that is used to describe the change in heat energy when the temperature of a material changes from one temperature to another. Enthalpy cannot be detected directly and it has no absolute value. What can be measured is the change in enthalpy relative to some initial condition or to a standard reference condition. It is measured in units of kJ/kg, kJ/kg-mol, Btu/lb, or Btu/lb-mol.

**#1**  
in eco-friendly  
attitude

**STUDY AT  
LINKÖPING UNIVERSITY, SWEDEN**  
RANKED AMONG TOP 50 UNIVERSITIES UNDER 50

Interested in Strategy and Management in International Organisations? Kick-start your career with a master's degree from Linköping University, Sweden.

→ **Click here!**

 **Linköping University**



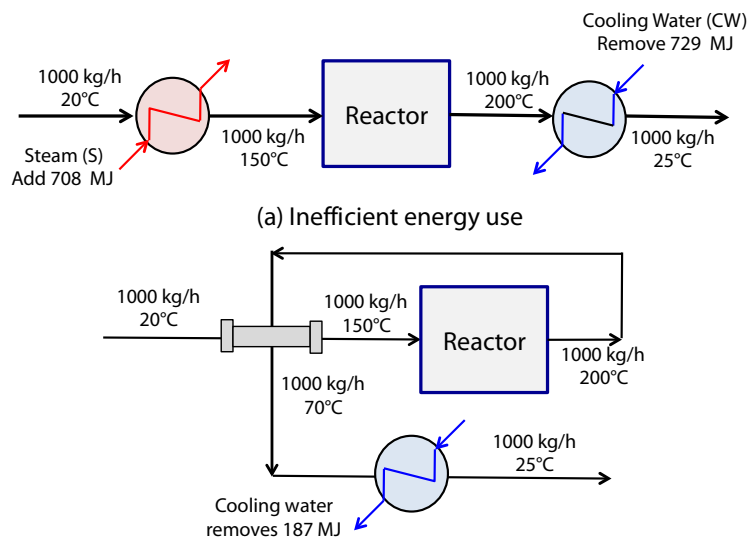
# 11 Energy Conservative Design

## 11.1 The Design Problem

Conserving energy use usually conserves water use and that reduces the demand for waste treatment. This is a win-win-win situation.

One way to reduce energy use is to use more efficient devices to transform energy, e.g., buy high efficiency motors and pumps or install more efficient lighting systems. Another is to be more efficient in the exchange and recovery of heat by designing efficient heat exchanger networks.

Energy can be recovered by transferring heat from a hot stream to a colder stream by means of a heat exchanger. The real significance of the second law is often directional, as well as quantitative. Even without calculations, the second law can give insights into the design of a process, or to the improvement of an existing design.



**Figure 11.1.** A simple energy integration system conserves energy.

Figure 11.1(a) shows a reactor that uses feedstock that is available at 20°C and a product stream that must be delivered at 25°C (to stop further reaction or to assist a following process). To improve the conversion in the reactor, the input is heated from 20°C to 150°C by adding steam in the amount of 708 MJ. Chemical reactions inside the reactor release heat and the output leaves at 200°C. Cooling water is used to remove 729 MJ from the output stream. This wastes energy by dumping heat energy from the reactor into cooling water.



Figure 11.1(b) shows how the hot reactor output can be used to heat the input stream. In the heat exchange, the same 708 MJ provided by steam in the original design is transferred from the hot reactor output stream to the cold input stream. Cooling water use is four times smaller because only 187 MJ needs to be removed.

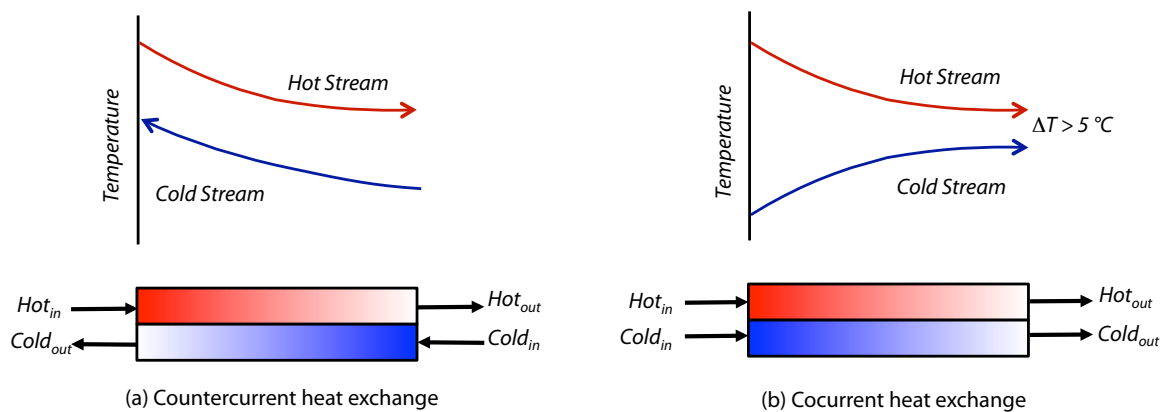
## 11.2 Heat Exchangers

Heat exchangers are the essential element in energy system integration. Two incoming flows, which may be gas or liquid, are separated by a metal surface and heat moves across the surface from the warmer flow to the colder one. The internal geometry of the heat transfer surface, its material (corrosion resistance is important in most applications), and other construction details exist in many variations and combinations. These details will be overlooked in order to focus on how much heat can be exchanged and how heat exchangers are networked for energy recovery efficiency.

Figures 11.2 shows countercurrent and cocurrent flow through an idealized heat exchanger. The cost of a heat exchanger depends on the surface area across which the heat energy moves from the hot stream to the cold stream. The greater the temperature difference between the two streams, the faster heat is transferred and the smaller the heat exchanger can be. This is accomplished by having counter-current flow of the hot and cold streams.

In a co-current flow heat exchanger, the benefit of a large initial temperature difference is quickly lost as the two streams approach a common temperature mid-way between the temperatures of the entering hot and cold streams. In countercurrent flow, the exiting hot stream can be cooled to near the entering cold stream temperature and the exiting cold stream temperature can approach the incoming hot stream temperature. This gives a larger ‘average’ temperature difference and makes a countercurrent heat exchanger more efficient than the cocurrent design.

The practical operating difference for effective heat exchange is  $\Delta T = 5^\circ\text{C}$ ; working at a smaller  $\Delta T$  wastes investment in the heat exchanger.



**Figure 11.2** Countercurrent heat exchange is much more efficient than a cocurrent arrangement.

The general heat transfer equation for a heat exchanger is

$$Q = U A \Delta T_m$$

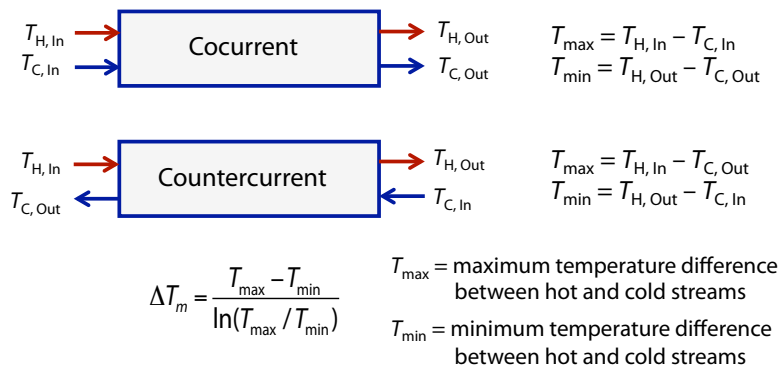
where  $Q$  is the amount of heat transferred (MJ/h, W, or Btu/h)

$U$  is the overall heat transfer coefficient (MJ/h-m<sup>2</sup>°C, W/m<sup>2</sup>°C, or Btu/h-ft<sup>2</sup>°F)

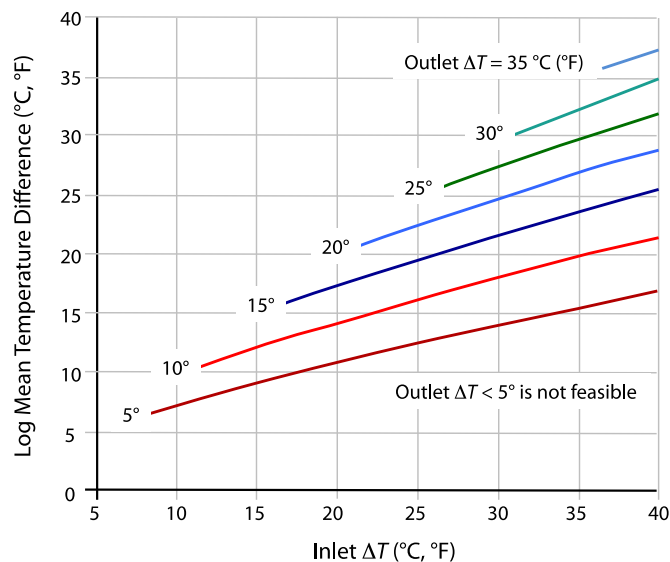
$A$  is the area of the heat transfer surface (m<sup>2</sup> or ft<sup>2</sup>), and

$\Delta T_m$  is the log mean temperature difference (°C or °F) between the hot and cold streams.

The log mean temperature difference,  $\Delta T_m$ , is calculated using the temperature difference at the two ends of the heat exchanger for both concurrent or countercurrent flow, as shown in Figure 11.3. The larger difference is defined as  $T_{max}$  and smaller difference is  $T_{min}$ . The hot stream is identified by the subscript  $H$ , as in  $T_H$ . Likewise the cold stream is labeled  $T_C$ . Figure 11.4 is a graphical estimation of  $\Delta T_m$ .



**Figure 11.3** Definition of the log-mean temperature difference in heat exchangers. (Note: These equations are modified for condensers and boilers.)



**Figure 11.4** Graphical estimation of the log mean temperature difference. Horizontal axis is the temperature difference at the heat exchanger inlet. The numbers beside the curves are the temperature difference at the heat exchanger outlet. An outlet difference less than 5°C is not feasible. (adapted from The Engineering Toolbox)

The value of the overall heat transfer coefficient depends on the physical arrangement and material, and the hot and cold fluids. As a rough guide ( $1 \text{ BTU/h-}^\circ\text{F-ft}^2 = 5.67 \text{ W/m}^2\text{-}^\circ\text{C} = 20 \text{ kJ/h-m}^2\text{-}^\circ\text{C}$ ).

Gas-gas exchange	$U = 10 - 100 \text{ W/m}^2\text{-}^\circ\text{C}$ $U = 40 - 400 \text{ kJ/h-m}^2\text{-}^\circ\text{C}$ $U = 2 - 20 \text{ Btu/h-}^\circ\text{F-ft}^2$
Liquid-liquid exchange	$U = 500 - 5000 \text{ W/m}^2\text{-}^\circ\text{C}$ $U = 2000 - 20,000 \text{ kJ/h-m}^2\text{-}^\circ\text{C}$ $U = 100 - 1000 \text{ Btu/h-}^\circ\text{F-ft}^2$
Boiling liquids or condensing vapors	$U = 1000 - 100,000 \text{ W/m}^2\text{-}^\circ\text{C}$ $U = 4000 - 400,000 \text{ kJ/h-m}^2\text{-}^\circ\text{C}$ $U = 200 - 20,000 \text{ Btu/h-}^\circ\text{F-ft}^2$



"I studied English for 16 years but...  
...I finally learned to speak it in just six lessons"

Jane, Chinese architect

ENGLISH OUT THERE

Click to hear me talking before and after my unique course download

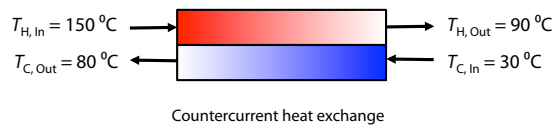
**Example 11.1 HEAT EXCHANGER AREA CALCULATION**

A heat exchanger will transfer  $Q = 1,000 \text{ MJ/h}$  and operates with  $U = 1.4 \text{ MJ/h}\cdot\text{m}^2\cdot^\circ\text{C}$ .

*Countercurrent heat exchange*

$$\begin{aligned} T_{H, \text{In}} &= 150^\circ\text{C} & T_{H, \text{Out}} &= 90^\circ\text{C} \\ T_{C, \text{Out}} &= 80^\circ\text{C} & T_{C, \text{In}} &= 30^\circ\text{C} \end{aligned}$$

$$\begin{aligned} T_{\text{max}} &= T_{H, \text{In}} - T_{C, \text{Out}} = 150^\circ\text{C} - 80^\circ\text{C} = 70^\circ\text{C} \\ T_{\text{min}} &= T_{H, \text{Out}} - T_{C, \text{In}} = 90^\circ\text{C} - 30^\circ\text{C} = 60^\circ\text{C} \end{aligned}$$



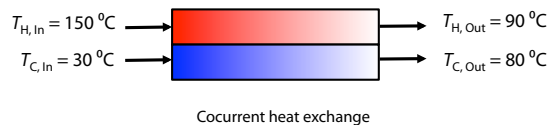
$$\Delta T_m = \frac{T_{\text{max}} - T_{\text{min}}}{\ln(T_{\text{max}}/T_{\text{min}})} = \frac{70 - 60}{\ln(70/60)} = 64.9^\circ\text{C}$$

$$A = Q/UA\Delta T_m = (1000 \text{ MJ/h})/(1.4 \text{ MJ/h}\cdot\text{m}^2\cdot^\circ\text{C})(64.9^\circ\text{C}) = 11 \text{ m}^2$$

*Cocurrent heat exchange*

$$\begin{aligned} T_{H, \text{In}} &= 150^\circ\text{C} & T_{H, \text{Out}} &= 90^\circ\text{C} \\ T_{C, \text{In}} &= 30^\circ\text{C} & T_{C, \text{Out}} &= 80^\circ\text{C} \end{aligned}$$

$$\begin{aligned} T_{\text{max}} &= T_{H, \text{In}} - T_{C, \text{In}} = 150^\circ\text{C} - 30^\circ\text{C} = 120^\circ\text{C} \\ T_{\text{min}} &= T_{H, \text{Out}} - T_{C, \text{Out}} = 90^\circ\text{C} - 80^\circ\text{C} = 10^\circ\text{C} \end{aligned}$$



$$\Delta T_m = \frac{T_{\text{max}} - T_{\text{min}}}{\ln(T_{\text{max}}/T_{\text{min}})} = \frac{120 - 10}{\ln(120/10)} = 44.4^\circ\text{C}$$

$$A = Q/UA\Delta T_m = (1000 \text{ MJ/h})/(1.4 \text{ MJ/h}\cdot\text{m}^2\cdot^\circ\text{C})(44.4^\circ\text{C}) = 16 \text{ m}^2$$

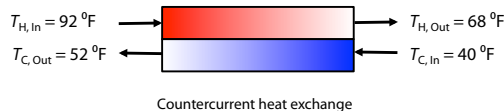
The cocurrent heat exchanger is 45% larger than the countercurrent exchanger that does the same work.

**Example 11.2 HEAT TRANSFER**

Calculate the heat transfer surface area of a heat exchanger that must transfer 1000 Btu/min if the heat transfer coefficient is  $U = 25 \text{ Btu/h}\cdot\text{ft}^2\cdot^\circ\text{F}$ . The temperature of the liquid to be cooled is  $92^\circ\text{F}$  at the inlet and the inlet cooling water temperature is  $40^\circ\text{F}$ . The temperatures of the exiting liquid and cooling water are  $68^\circ\text{F}$  and  $52^\circ\text{F}$ , respectively. Assume countercurrent flow of the liquid and the cooling water.

$$\begin{aligned} T_{H, \text{In}} &= 92^\circ\text{F} & T_{H, \text{Out}} &= 68^\circ\text{F} \\ T_{C, \text{Out}} &= 52^\circ\text{F} & T_{C, \text{In}} &= 40^\circ\text{F} \end{aligned}$$

$$\begin{aligned} T_{\text{max}} &= T_{H, \text{In}} - T_{C, \text{Out}} = 92^\circ\text{F} - 52^\circ\text{F} = 40^\circ\text{F} \\ T_{\text{min}} &= T_{H, \text{Out}} - T_{C, \text{In}} = 68^\circ\text{F} - 40^\circ\text{F} = 28^\circ\text{F} \end{aligned}$$



$$\Delta T_m = \frac{T_{\text{max}} - T_{\text{min}}}{\ln(T_{\text{max}}/T_{\text{min}})} = \frac{40 - 28}{\ln(40/28)} = 33.6^\circ\text{F}$$

$$A = Q/UA\Delta T_m = (1000 \text{ Btu/min})(60\text{min/h})/(25 \text{ Btu/h}\cdot\text{ft}^2\cdot^\circ\text{F})(33.6^\circ\text{F}) = 71.4 \text{ ft}^2$$

**Example 11.3 ODOR CONTROL**

A packinghouse rendering process vents 25,000 kg/h of steam at 2300 kJ/kg heat energy. Odorous compounds emitted with the steam can be removed by condensing the steam and cooling the condensed water below 70°C. A condenser with  $A = 420 \text{ m}^2$  heat exchange area and a heat transfer coefficient  $U = 2,400 \text{ kJ/h}\cdot\text{m}^2\cdot^\circ\text{C}$  can operate at a log mean temperature difference  $\Delta T_m = 60^\circ\text{C}$ .

The heat transferred in the heat exchanger is:

$$Q = UA\Delta T_m = \left(2,400 \frac{\text{kJ}}{\text{h}\cdot\text{m}^2\cdot^\circ\text{C}}\right)(420 \text{ m}^2)(60^\circ\text{C}) = 60,500 \text{ MJ/h}$$

Condensing the steam to water (at 100°C) requires 2257 kJ/kg, for a heat requirement of

$$Q = mH_v = (25,000 \text{ kg})(2,257 \text{ kJ/kg}) = 56,426 \text{ MJ/h}$$

The additional heat transferred cools the 100°C water to  $T_{out}$

$$\left(25,000 \frac{\text{kg}}{\text{h}}\right)\left(4.184 \frac{\text{kJ}}{\text{kg}\cdot^\circ\text{C}}\right)(100^\circ\text{C} - T_{out}) = 60,500 \text{ MJ/h} - 56,426 \text{ MJ/h} = 4,075 \text{ MJ/h}$$

$$100^\circ\text{C} - T_{out} = \frac{4,075,000 \text{ kJ/h}}{(25,000 \text{ kg/h})(4.184 \text{ kJ/kg}\cdot^\circ\text{C})} = 39^\circ\text{C}$$

$$T_{out} = 100^\circ\text{C} - 39^\circ\text{C} = 61^\circ\text{C}$$

Condensation will solve the odor problem.

### 11.3 Heat Exchanger Networks (HENs)

A process may have several streams that need to be heated or cooled and the maximization of heat recovery requires that a network of heat exchangers should be used. This section shows what can be done with an intelligent arrangement, but without explaining the design strategy.

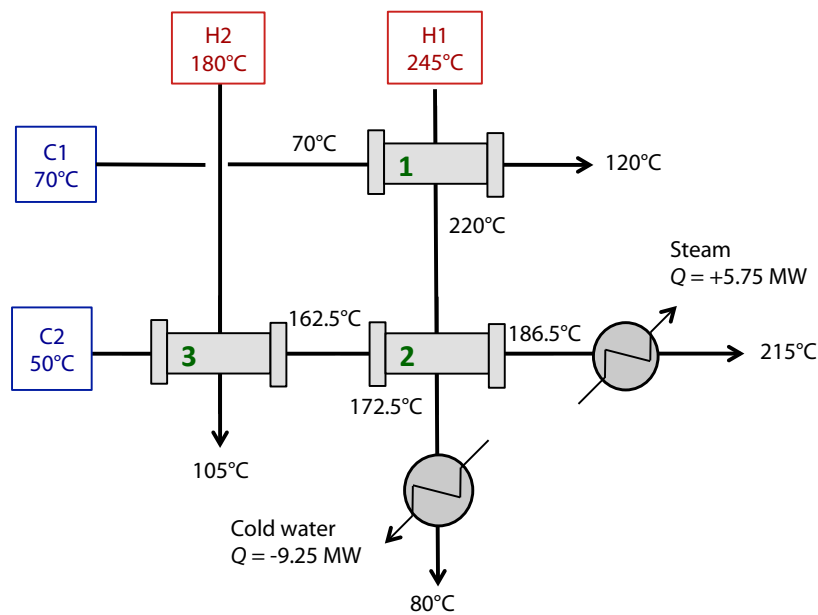
Figure 11.5 shows a heat exchange network (HEN) with three heat exchangers (labeled 1, 2, and 3), two hot streams (H1 and H2) and two cold streams (C1 and C2). The relative mass flows are  $C1 = 1$ ,  $C2 = 4$ ,  $H1 = 2$ , and  $H2 = 3$ .

The objective is to achieve target temperatures for the hot and cold streams with the least use of steam or cold water. Table 11.1 shows initial and target stream temperatures, the heat to be added (+) or removed (–) and the ratio of the flow heat capacities ( $mc_p$ ) between the hot and cold streams. The sum of the required heat additions and removals is  $(2.5 + 33.0 - 16.5 - 22.5) = -3.5 \text{ MW}$ .

A practical technical limitation is that the minimum temperature difference between a hot stream and a cold stream is 5°C. This limit is reached in exchanger number 2: the temperature difference is 10°C ( $172.5^\circ\text{C} - 162.5^\circ\text{C}$ ). Steam provides 5.75 MW heat and cooling water removes 9.25 MW. Furthermore, an energy balance (first law of thermodynamics) requires that any heat added from steam be accompanied by a commensurate increase in cooling water duty. The use of 5.75 MW of steam in the proposed initial HEN requires  $5.75 + 3.5 = 9.25 \text{ MW}$  of cooling water.

Stream	Supply temp. (°C)	Target temp. (°C)	$mc_p$ MW/°C	Heat to be added (+) or removed (-)	Ratio of $mc_p$ Hot to Cold stream	
H1	245	80	0.1	-16.5		
H2	180	105	0.3	-22.5		
C1	70	120	0.05	2.5	2	6
C2	50	215	0.2	33.0	0.5	1.5

**Table 11.1** Data for the heat exchanger network problem (energy units are megawatts, MW).



**Figure 11.5** Original heat exchanger network (Sama 1995).  
(Relative mass flows are  $C1 = 1$ ,  $C2 = 4$ ,  $H1 = 2$ , and  $H2 = 3$ .)

The guidelines in Table 11.2 may not lead to the optimal design, but they are instructive for a general understanding of how to improve a heat exchanger network.

Design Guideline

1. The larger the mass flow, the larger the opportunity to save (or waste) energy.
2. Minimize the mixing of streams with differences in temperature, pressure, or chemical composition.
3. Do not discard heat at high temperatures to the ambient, or to cooling water.
4. Do not heat refrigerated streams with hot streams or with cooling water.
5. When choosing streams for heat exchange, try to match streams where the final temperature of one is close to the initial temperature of the other.
6. When exchanging heat between two streams, the exchange is more efficient if the flow heat capacities of the streams are similar. If there is a big difference between the two, consider splitting the stream with the larger flow heat capacity.
7. Minimize the use of intermediate heat transfer fluids when exchanging heat between two streams.
8. Heat (or refrigeration) is more valuable when its temperature is farther from ambient.
9. Do not use excessively large or excessively small thermodynamic driving forces in process operations.
10. The economic optimum  $\Delta T$  at a heat exchanger decreases as the temperature decreases and, vice versa.

Table 11.2 Some Common Sense Second Law Guidelines (Sama 1995)

The guidelines in Table 11.2 identify three important design decisions and potential improvements in the network in Figure 11.4.

Excellent Economics and Business programmes at:



university of  
 groningen



“The perfect start  
of a successful,  
international career.”

**CLICK HERE**  
to discover why both socially  
and academically the University  
of Groningen is one of the best  
places for a student to be

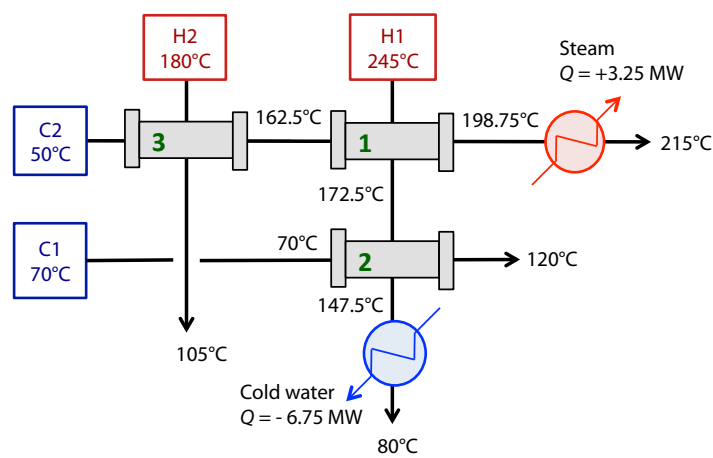
[www.rug.nl/feb/education](http://www.rug.nl/feb/education)



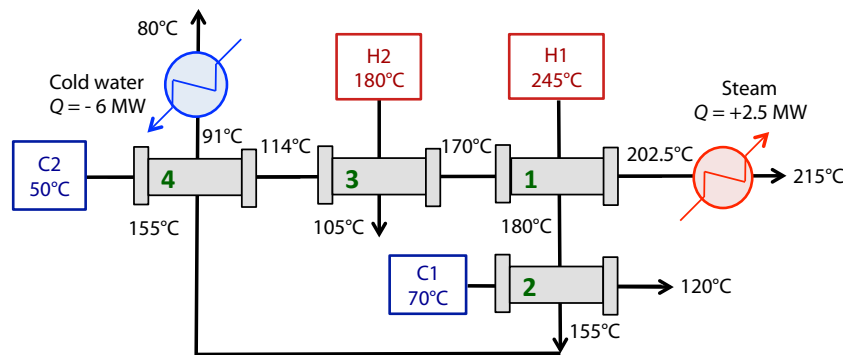
**Guideline #5.** The first heat exchange match for stream H1 (the hottest stream) at 245°C should be with C2, the cold stream that needs to be heated to the highest temperature, 215°C. For stream C2, this should be its final match before its need for heat from steam.

**Guideline #6.** The ratio of the flow heat capacity between streams H1 and C1 is 2, while that ratio between H2 and C1 is 6. This indicates that H1 should be used to heat C1 and that a match between stream H2 and C1 should be avoided. If a match between H2 and C1 cannot be avoided, the possibility of splitting stream H2 should be considered.

**Guideline #3** says “Do not discard heat at high temperature to the ambient, or to cooling water.” In the original network, heat is discarded to cooling water from stream H1 at 172.5°C .



(a) Improved network



(b) Maximum energy recovery network

**Figure 11.6** (a) An improved heat exchanger network. (b) Maximum energy recovery heat exchanger network (Sama 1995). (The relative mass flows are C1 = 1, C2 = 4, H1 = 2, and H2 = 3.)

Improved networks for energy recovery are shown in Figure 11.6. The system in 11.6(a) reduces steam and cooling water by 43% and 27%, respectively, from the original design. In this network, stream C2, after cooling stream H2, is used to cool stream H1 first, as suggested by guidelines 5 and 6. Using guideline 3, stream C1 then further cools H1 to a lower temperature than the original design (147.5 vs. 172.5) in heat exchanger 2.

The network in 11.6(b), which is an optimal energy recovery scheme, requires only 2.5 MW of heat from steam and reduces steam and cooling water by 57% and 35%, respectively.

## 11.4 Pinch Analysis for Heat Exchanger Network Design

The use of a composite mass-concentration diagram to identify water reuse opportunities was outlined in Chapter 8. *Pinch analysis* is a similar method for analyzing efficient heat exchanger networks that uses an enthalpy-temperature diagram on which are plotted curves for the hot streams and the cold streams. Pinch analysis will find the most effective network, whereas the more intuitive analysis in the previous section may not, even in fairly small networks.

Heat exchanger network (HEN) design falls within the realm of chemical and mechanical engineers. Work on systematic design of networks was established years ago (Holman 1971, Linhoff & Hindmarsh 1983, Rudd et al 1973). Later work has improved the methods and provided computer-aided design software and a vast literature can be found on-line.

Two freeware programs that use thermodynamic pinch analysis for heat exchanger network design are THEN (Knopf 2009) and HINT (Martin and Mato 2008). They integrate networks of heat exchangers, boilers, condensers and furnaces for best energy utilization. Grand composite curves (analogous to the mass-composite curve for water reuse system analysis) can be plotted to show the enthalpy of the process streams as a function of temperature. They also show the heat exchanger network design in a graphical form as a grid diagram for visualization of the network configuration.

## 11.5 Conclusion

Recovery of heat within the processing system is essential for energy and water conservation. Heat that is removed to cooling water and dumped to the environment is wasted energy. The goal is to minimize this by designing efficient heat exchange networks.

Energy conservative design is important because heating and cooling are expensive. The pumps, heat exchangers, and cooling towers are expensive to maintain because of problems with scaling and corrosion.

Countercurrent heat exchangers are the most efficient design because they have the highest average temperature difference and this translates to the minimum exchange surface area.

# 12 Combustion of Municipal Refuse and Biogas

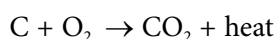
## 12.1 The Design Problem

When a waste material, such as municipal refuse or landfill gas, is considered as a fuel the design problems are to determine its composition so the pollution potential of the end products are known and to determine how much useful energy will be released so the economics can be calculated.

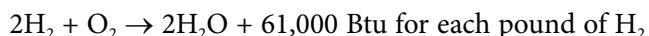
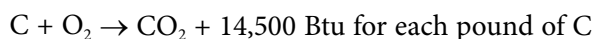
Combustion products may be completely harmless or harmful, and this is often determined by the combustion conditions. Carbon will burn to carbon monoxide (CO) or carbon dioxide (CO<sub>2</sub>). For many years we thought CO<sub>2</sub> was harmless, but the increasing amount of CO<sub>2</sub> in the atmosphere is causing climate change. Combustion can convert nitrogen to nitrous oxides (NO<sub>x</sub>), which are air pollutants and contribute to smog formation. Sulfur burns to form sulfur dioxide (SO<sub>2</sub>) and sulfate (SO<sub>4</sub><sup>2-</sup>).

## 12.2 Combustion Stoichiometry

The simplest possible description of combustion is

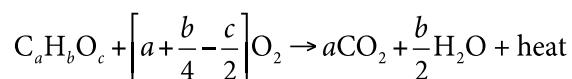


The most important product is the heat. The basic combustion reactions for carbon and hydrogen are:



The amount of heat released cannot be calculated from the stoichiometry but data are available on the heating value of liquids and solids that can be used as fuels. Section 12.4 is an introduction to the available data.

A combustible waste can be analyzed for carbon, hydrogen, oxygen, and other elements. A simplified empirical formula of the main constituents of a dry material is C<sub>a</sub>H<sub>b</sub>O<sub>c</sub> and a generic reaction is



The end products are carbon dioxide (CO<sub>2</sub>), a greenhouse gas, and water vapor (H<sub>2</sub>O).

The stoichiometric equation must be balanced. That is, it must satisfy the law of conservation of mass. The stoichiometric coefficients (*a*, *b*, *c*) must take on values so that the number of atoms of C, H, and O are equal for reactants and products.

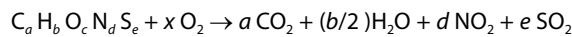
All of the carbon goes to  $\text{CO}_2$  so  $a$  atoms of carbon in the fuel create  $a$  molecules of  $\text{CO}_2$ . This requires  $2a$  atoms of oxygen. The hydrogen from the fuel forms water. Specifically,  $b$  atoms of H are used to create  $b/2$  molecules of  $\text{H}_2\text{O}$ . This requires  $b/2$  atoms of oxygen. The stoichiometric coefficient for oxygen must make the number of atoms of oxygen on the reaction side equal the number of atoms on the products side. The atoms of oxygen coming from  $\text{O}_2$  is  $(2a + b/2 - c)$ . Each molecule of oxygen gas provides 2 atoms of O and the coefficient is  $(2a + b/2 - c) / 2 = a + b/4 - c/2$ .

More directly, say the coefficient of  $\text{O}_2$  is  $x$ . The equation is balanced when

$$2x + c = 2a + b/2 \text{ and } x = a + b/4 - c/2$$

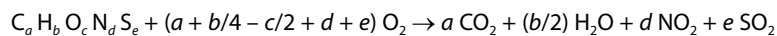
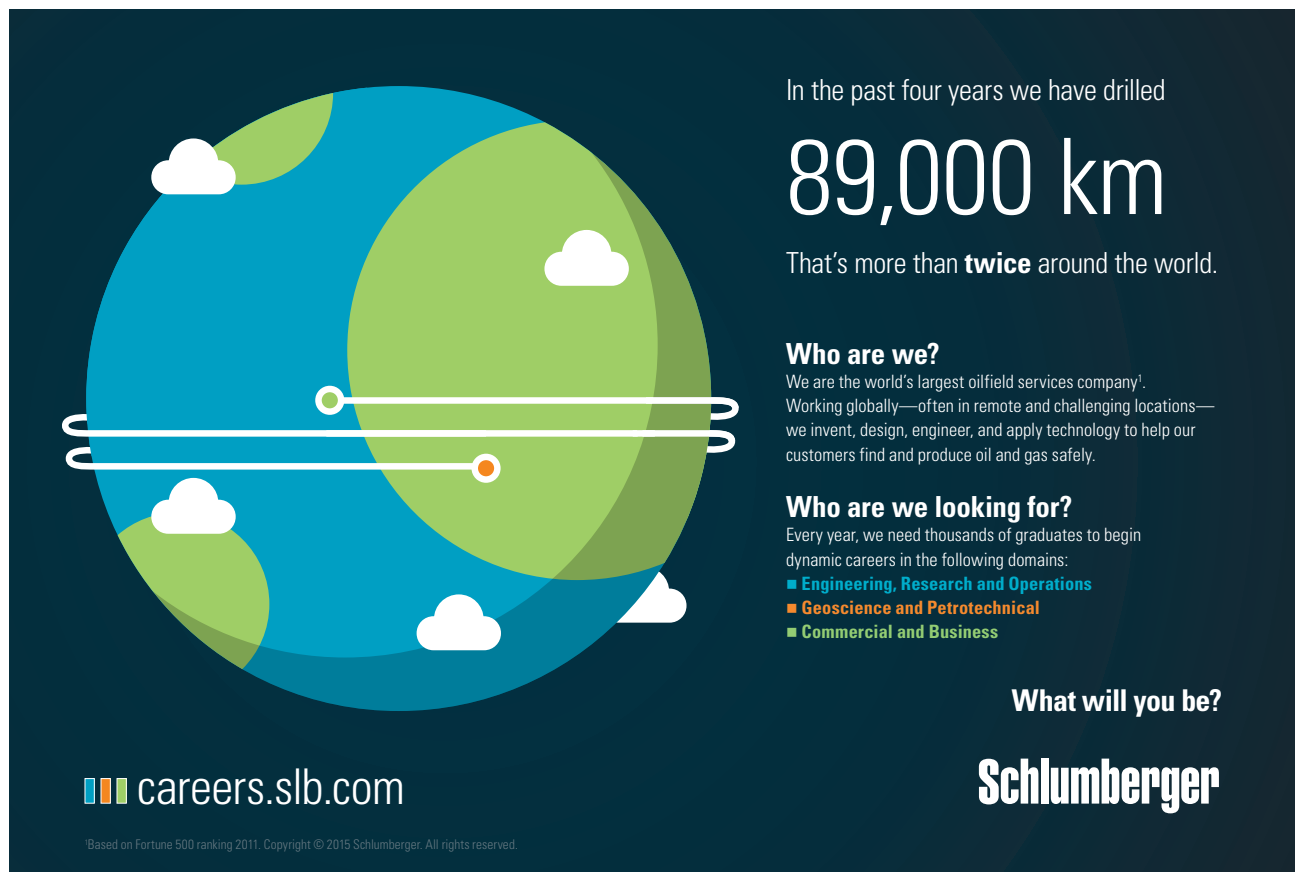
**Example 12.1** COMBUSTION OF ORGANICS

An organic material consisting of carbon, hydrogen, oxygen, nitrogen and sulfur has an empirical chemical formula  $\text{C}_a\text{H}_b\text{O}_c\text{N}_d\text{S}_e$ . Write a balanced reaction for the complete combustion of this material.



Balance the oxygen:  $2x + c = 2a + b/2 + 2d + 2e$

$$x = a + b/4 - c/2 + d + e$$

In the past four years we have drilled

# 89,000 km

That's more than **twice** around the world.

**Who are we?**  
We are the world's largest oilfield services company<sup>1</sup>. Working globally—often in remote and challenging locations—we invent, design, engineer, and apply technology to help our customers find and produce oil and gas safely.

**Who are we looking for?**  
Every year, we need thousands of graduates to begin dynamic careers in the following domains:

- Engineering, Research and Operations
- Geoscience and Petrotechnical
- Commercial and Business

**What will you be?**

[careers.slb.com](https://careers.slb.com)

**Schlumberger**

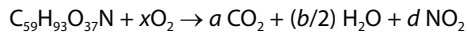
<sup>1</sup>Based on Fortune 500 ranking 2011. Copyright © 2015 Schlumberger. All rights reserved.



**Example 12.2** COMBUSTION OF MUNICIPAL REFUSE

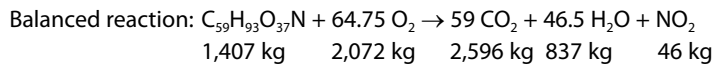
A dried municipal refuse has the following empirical chemical composition,  $C_{59}H_{93}O_{37}N$ . Find the mass of oxygen required to completely combust 1000 kg/h of this material.

The balanced combustion reaction is



where  $a = 59$ ,  $b = 93$ ,  $c = 37$ , and  $d = 1$

$$x = a + b/4 - c/2 + d = 59 + 93/4 - 37/2 + 1 = 64.75$$



The stoichiometric oxygen requirement is

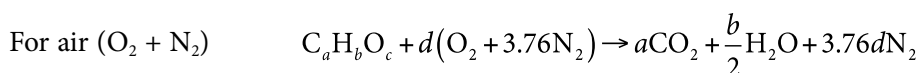
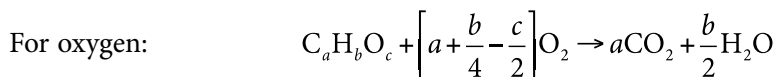
$$\text{mass } O_2 = \left( \frac{1000 \text{ kg/h refuse}}{1407 \text{ kg refuse/kg-mol refuse}} \right) \left( 2072 \frac{\text{kg } O_2}{\text{kg-mol refuse}} \right) = 1773 \text{ kg } O_2/\text{h}$$

The mass of air that will supply this amount of oxygen, assuming air is 23.2%  $O_2$  by weight, is

$$\text{mass of air} = (1773 \text{ kg } O_2/\text{h})/0.232 = 7,642 \text{ kg/h}$$

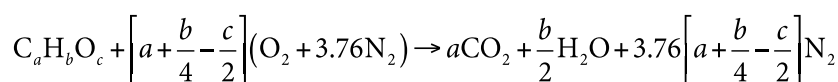
Some excess air beyond the stoichiometric requirement will be needed to have complete combustion.

The convention for writing balanced stoichiometric equations is that non-reactive substances are not included. Some overlook this convention for combustion stoichiometry because air is always added to the process. Most of the oxygen in the air is consumed by the fuel oxidation, but there is some excess. The operating targets for some equipment include a percentage of oxygen in the exhaust gas to make sure combustion is complete. Including air in the stoichiometry links this percentage to the excess air that is provided.

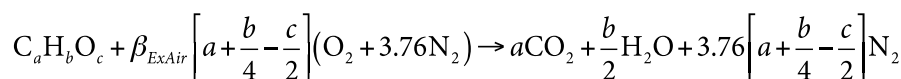


The 3.76 factor for  $N_2$  comes from the ratio of nitrogen to oxygen in air. The volume fractions are 79%  $N_2$  and 21%  $O_2$ . The molar fractions are the same, 79% and 21%, and  $79/21 = 3.76$ . That is, 3.76 moles of nitrogen accompany each mole of oxygen in the air.

Once again it is required that  $c + 2d = 2a + b/2$  and  $d = a + b/4 - c/2$  and

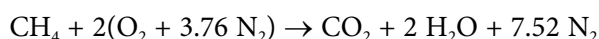


This can be modified with a factor,  $\beta_{ExAir}$ , that accounts for excess air

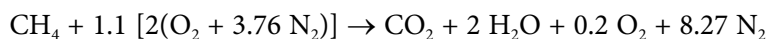


For 10% excess air  $\beta_{ExAir} = 1.1$ ; for 25% excess air  $\beta_{ExAir} = 1.25$ .

Burning methane (CH<sub>4</sub>) in air is



Burning methane with 10% excess air gives



The *stoichiometric ratio* is the ideal fuel ratio where all fuel and air are consumed without any excess left over. In practice, burning conditions are never ideal and more air than ideal must be supplied for complete combustion. The amount of air above the theoretical requirement is referred to as *excess air*.

Insufficient air supply to the burner causes unburned fuel, soot, smoke, and carbon monoxide exhausts, and other problems that result in heat transfer surface fouling, pollution, lower combustion efficiency, flame instability and a potential for explosion.

Boilers and high temperature process furnaces usually incorporate a modest amount of excess air, about 10 to 20% more than what is needed to burn the fuel completely. Power plant boilers normally run about 10 to 20 percent excess air. Natural gas-fired boilers may run as low as 5 percent excess air. Pulverized coal-fired boilers may run with 20 percent excess air. Gas turbines run very lean with up to 300 percent excess air.

The stoichiometric reaction does not show impurities and inert substances in the fuel, such as trace elements (i.e., Hg and Cl), moisture or ash. Trace elements (<1% of total by dry weight) may become gases, acids, fumes, or ash.

If the fuel (C<sub>a</sub>H<sub>b</sub>O<sub>c</sub>) contains a few elements that form gases, such as N, or S, these will be liberated from the parent molecule and the combustion products will include SO<sub>2</sub>, SO<sub>3</sub>, NO<sub>2</sub>, NO<sub>x</sub>. Sulfuric acid (H<sub>2</sub>SO<sub>4</sub>) and nitric acid (HNO<sub>3</sub>) are formed when these products react with water vapor.

Elements such as mercury (Hg), chlorine (Cl), fluorine (F), copper (Cu) can form toxic metal fumes (Hg and Cu) and acids (HCl and HF). Elements such as iron (Fe), phosphorus (P), calcium (Ca) do not form gases or fumes and they become part of the ash.

Knowing the combustion products is important for selecting materials of construction to avoid corrosion, and in selecting additional air pollution control equipment to neutralize the acidic compounds. The chemistry of combustion is complicated by inefficiencies and side reactions. These complications are handled by specialists.

### 12.3 Composition of Solid Waste

The composition of residential, municipal, commercial, or industrial solid waste is highly variable with season, city, state and country. Even so, it is helpful to have an idea of the composition of the most common components in residential solid waste. This information is in Table 12.1. The percentages for carbon, hydrogen, etc. apply to the dry weight fraction of the solid waste component. Example 12.3 shows how these data are used to calculate the empirical stoichiometric formula for a mixed waste.

Component	Dry solids content (%)	Water Content (%)	Elemental Composition of Dry Waste (mass %)					Ash
			Carbon (C)	Hydrogen (H)	Oxygen (O)	Nitrogen (N)	Sulfur (S)	
<b>Organic</b>								
Food wastes	30	70	48.0	6.4	37.6	2.6	0.4	5.0
Paper	94	6	43.5	6.0	44.0	0.3	0.2	6.0
Cardboard	95	5	44.0	5.9	44.6	0.3	0.2	5.0
Plastics	99	1	66.0	7.2	22.8	--	--	10.0
Textiles	90	10	55.0	6.6	31.2	4.6	0.15	2.5
Rubber	100	0	78.0	10.0	--	2.0	--	10.0
Leather	80	20	60.0	8.0	--	2.0	--	10.0
Yard wastes	35	65	47.8	38.0	3.4	0.3	4.5	4.5
Wood	80	20	49.5	42.7	0.2	0.1	1.5	1.5
<b>Inorganic</b>								
Glass	97	3	0.5	0.1	0.4	<0.1	--	98.9
Metals	97	3	4.5	0.6	4.3	<0.1	--	90.5
Dirt, ash, etc.	97	3	26.3	3.0	2.0	0.5	0.2	68.0

**Table 12. 1** Empirical composition of the combustible components of residential solid waste in the U.S. (Source: Vesiland et al. 2001, Reinhart 2004).



**Example 12.3** EMPIRICAL STOICHIOMETRIC FORMULA FOR A MIXED SOLID WASTE

Large quantities of mixed solid waste are available as a fuel. A representative sample of the waste has this as-delivered (wet) composition: 40 kg paper, 10 kg cardboard, 15 kg plastics, and 10 kg wood. The moisture content for each component, given in Table 12.2, is used to calculate the kilograms of dry solids and water in the sample that are found in columns 5 and 6.

The elemental composition of each component is calculated using the percentages in Table 12.1.

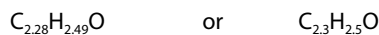
Composition of solid waste	Wet mass (kg)	Moisture Content %	Dry solids (kg)	Water (kg)	Elemental Composition of Dry Solids (kg)					
					C	H	O	N	S	Ash
Paper	40	6	37.6	2.4	16.356	2.256	16.544	0.1128	0.075	2.256
Cardboard	10	5	9.5	0.5	4.180	0.5605	4.237	0.028	0.019	0.475
Plastics	15	1	14.85	0.15	8.910	1.0692	3.386	0	0	1.485
Wood	10	20	8	2	3.960	0.480	3.416	0.016	0.008	0.12
Total	75	5.05	69.95	5.05	33.406	4.366	27.583	0.1573	0.102	4.336

**Table 12.2** Calculation of the elemental composition of a waste mixture

Element	Mass (kg)	Atomic Mass (kg/mol)	Moles	Mole Ratios		
				C = 1	N = 1	S = 1
C	33.406	12.01	2.279	2.28	59.2	654.9
H	4.366	1.01	3.575	2.49	92.9	1027.4
O	27.583	16.00	1.434	1.00	37.3	412.2
N	0.157	14.01	0.0385		1.0	11.1
S	0.102	32.07	0.0035			1.0

**Table 12.3** Calculation of mole ratios for the stoichiometric formulation

The empirical stoichiometric compositions are



Including nitrogen and sulfur gives  $C_{59.2}H_{92.9}O_{37.3}N$  and  $C_{654.9}H_{1027.4}O_{412.2}N_{11.1}S$ . The sulfur and nitrogen content is irrelevant to the combustion of this material and the simplest formulation is sufficient.

## 12.4 Heating Value of Waste Materials

The production of municipal solid waste (MSW) in the U.S. in 2010 was about 225 million tons ( $2.25 \times 10^{11}$  kg). The composition of this waste is about 13% inert material (metal, glass, etc.), 25% moisture, and 50% combustible paper, wood, rubber, and plastic. By definition, municipal solid waste does not include industrial, agricultural, medical wastes or sewage sludge.

Table 12.4 lists the net heating value of several fuels, including some waste materials. The U.S. EPA considers any material with a minimum heating value of 5,000 to 8,000 Btu/lb (12,000–18,000 kJ/kg) to be a bona fide fuel.

Fuel	Btu/lb	kWh/lb	kJ/kg	kWh/kg
<b>Carbon</b>	14,100	4.13	32,800	9.61
<b>Coal</b>				
Illinois bituminous (8 % ash, 4% S)	11,500	3.37	26,700	7.84
Pennsylvania anthracite (8 % ash, 0.5% S)	13,500	3.96	31,400	9.20
West Virginia bituminous (4.5 % ash, 1% S)	14,500	4.25	33,700	9.89
<b>Liquids</b>				
Fuel oil (87.3% carbon)	18,000	5.28	41,900	12.27
Crude oil	19,000	5.57	44,200	12.95
Gasoline	20,000	5.86	46,500	13.64
<b>Gases</b>				
Landfill gas (50% methane)	11,500	3.37	26,700	7.84
Sludge digester gas (70% methane)	16,000	4.69	37,200	10.91
Natural gas	20,300	5.95	47,200	13.84
Methane	21,500	6.30	50,000	14.66
Ethane	20,300	5.95	47,200	13.84
Propane	19,800	5.80	46,100	13.50
Butane	20,000	5.86	46,500	13.64
<b>Waste materials (dry weight basis)</b>				
Unsorted raw municipal refuse (moist)	3,000-5,000	0.88-1.46	7,000-11,600	2.05-3.41
Dry combustibles from municipal refuse	8,000	2.34	18,600	5.45
Newsprint	7,800	2.29	18,100	5.32
Digested sewage sludge (40% ash)	5,300	1.55	12,300	3.61
Wastewater grease and scum (12% ash)	16,700	4.89	38,800	11.39
Rags (10% moisture, 2.5 % ash)	7,650	2.24	17,800	5.22
Waste sulfite liquor solids	7,900	2.32	18,400	5.39
Dry bagasse	8,000	2.34	18,600	5.45
Vinyl scrap	11,400	3.34	26,500	7.77
Foam, scrap	12,290	3.60	28,600	8.38
Tires	15,000	4.40	34,900	10.23
Used oil	18,000	5.28	41,900	12.27
Polyethylene film	19,160	5.62	44,600	13.06

Conversion Factors: 1 Btu/lb = 2.931 x 10<sup>-4</sup> kWh/lb = 6.463 x 10<sup>-4</sup> kWh/kg = 2.326 kJ/kg

**Table 12.4** Lower heating value of selected fuels and waste materials.

Water is a product of combustion. This water must be heated to the boiling point, vaporized, and the vapor must be heated to the temperature of the combustion gas. This consumes some of the heat released by the fuel. The *net heating value* is the amount of enthalpy (kJ/kg, Btu/lb) available after adjusting for water vapor produced during combustion. This value is sometimes called the *lower heating value*, to distinguish it from a *higher heating value* that would be available if water vapor were not involved.

**Example 12.4 REFUSE AS FUEL**

A refuse processing plant shreds 980 T/d of raw refuse in a hammermill. Metals are removed at the rate of 74 T/d. The remaining 906 T/d of solid material is mixed with coal according to heating value in proportions of 10% refuse and 90% coal and burned in an electric generating plant boiler. The refuse heating value is 5000 Btu/lb and the coal heating value is 12,000 Btu/lb. In order to burn all the processed refuse, the total daily energy input to the boiler is:

Refuse:  $(906 \text{ T/d})(2000 \text{ lb/T})(5000 \text{ Btu/lb}) = 9,060 \times 10^6 \text{ Btu}$   
Coal:  $(9 \text{ Btu coal/Btu refuse}) (9060 \times 10^6 \text{ Btu/d}) = 81,540 \times 10^6 \text{ Btu}$   
Total:  $90,600 \times 10^6 \text{ Btu}$

At 40% energy conversion, this should generate about

$$0.4(90,600 \times 10^6 \text{ Btu}) / (3412 \text{ Btu/kWh}) = 10.6 \times 10^6 \text{ kWh}$$

of electricity over a 24-h day. The energy from the refuse, accounts for ten percent of this total. The true energy yield of the refuse is lower because of the energy consumed in the shredding, sorting, and hauling.

## American online LIGS University

is currently enrolling in the  
Interactive Online **BBA, MBA, MSc,**  
**DBA and PhD** programs:

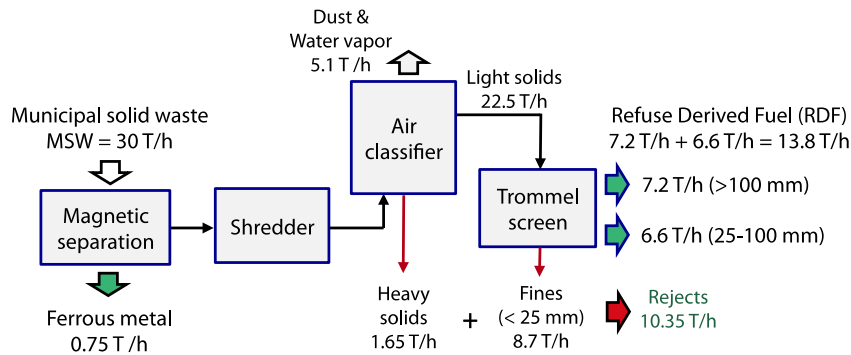
- ▶ enroll **by September 30th, 2014** and
- ▶ **save up to 16%** on the tuition!
- ▶ pay in 10 installments / 2 years
- ▶ Interactive **Online education**
- ▶ visit [www.ligsuniversity.com](http://www.ligsuniversity.com) to find out more!

Note: LIGS University is not accredited by any nationally recognized accrediting agency listed by the US Secretary of Education. More info [here](#).



**Example 12.6 UPGRADING THE FUEL VALUE OF SOLID WASTE**

Figure 12.1 shows the material flow in a 30,000 kg/h (30 T/h) municipal solid waste (MSW) test processing facility. Ferrous metals are removed by magnetic separation before the waste is shredded. Air classification separates lighter and heavier particles. The lighter material, which has a high organic content, is further separated into three size fractions with a trommel screen. The trommel overflow (material larger than 100 mm) is the lightest and has the highest organic content. This is the most desirable material for sale to power plants as *refuse derived fuel* (RDF). The mid-size fraction (25–100 mm) also can be used as RDF.



**Figure 12.1** Municipal solid waste sorting process.

The RDF yield from a 30 T/h input is the two larger size fractions discharged from the trommel screen. That is  
 $RDF = 7.2\text{ T/h} + 6.6\text{ T/h} = 13.8\text{ T/h}$

The sorting has produced these changes from MSW to RDF:

- Plastics content increased from 26% in the MSW to 68% in the RDF, on a dry weight basis.
- Food waste, metal, glass, and ceramics are almost zero in the trommel overflow.
- Water content of the trommel overflow decreased to 40% from 51% in the air classifier feed.
- Combustible content increased from 20% in the MSW to 29% in the RDF.
- Sulfur content decreased from 0.8% to 0.05%.
- Chlorine content increased from 0.18% to 0.23% because plastics have been concentrated in the RDF.
- Higher heat value increased from 2.65 kWh/kg in the MSW to 4.32 kWh/kg in the RDF.

The power requirement for the 30 T/h test facility was measured as:

Shredder = 825 kW	Magnetic separator = 5 kW
Trommel screen = 12 kW	Air classifier = 33 kW
Conveyors = 15 kW	Cyclone = 65 kW (air pollution control)

Energy used to produce 13.8 T/h (13,800 kg/h) of RDF, assuming an 8-hour operating day, is approximately  
 $= (955\text{ kW})(8\text{ h}) = 7,640\text{ kWh}$

Energy used per kg of RDF produced is  
 $= (955\text{ kW})(8\text{ h}) / (13,800\text{ kg}) = 0.554\text{ kWh/kg}$  of RDF produced.

Energy content of the 13.8 T/d of RDF, assuming an 8-hour operating day and a fuel value of 4.32 kWh/kg  
 $(13,800\text{ kg/h})(8\text{ h})(4.32\text{ kWh/kg}) = 477,000\text{ kWh}$

Net energy output of the process = 477,000 kWh – 7,640 kWh = 469,360 kWh

Net energy output per kg RDF produced = 4.32 kWh/kg – 0.554 kWh/kg = 3.765 kWh/kg

The energy used was less than 13% of the 4.32 kWh/kg fuel value of the RDF.

## 12.5 Incineration of Solid Waste and Sludge

Incineration is controlled combustion to reduce the volume and weight of waste. In Europe, most municipal refuse is incinerated. In the U.S. certain toxic chemicals and hospital wastes are incinerated, but municipal refuse generally is not, largely because the commonly held image of inefficient old-style systems, but also because of cost. New technology makes it possible to operate at higher temperatures with better control of combustion conditions. Also, new incinerators have highly efficient air pollution control systems. Burning wastes for heat recovery should be technically feasible in many situations. Economic feasibility is a separate question.

The heart of an incinerator system is the combustion chamber. The energy released by the combustion of the organics in the waste may not be sufficient to reach the desired reactor temperature, especially if the material is moist, and an auxiliary fuel such as natural gas must be added. Auxiliary air also may be needed to get complete combustion.

Incineration produces bottom ash, slag, and fly ash. Depending on the methods used for air pollution control, there may also be wastewater from ash handling and flue gas scrubbing.

## 12.6 Energy Recovery from Landfill Gas

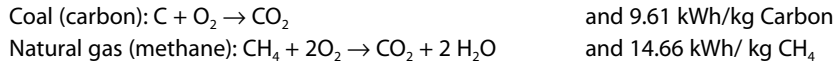
Biogas comes from anaerobic fermentation of organic compounds in municipal sludge digesters, agricultural manure digesters, anaerobic treatment of strong organic industrial wastes, and landfills. Biogas can be used directly or it can be converted to pipeline quality methane gas by removing most of the carbon dioxide and hydrogen sulfide.

Natural gas has the highest energy/carbon ratio of any fossil fuel, and thus produces less carbon dioxide per unit of energy. The primary component of natural gas is methane ( $\text{CH}_4$ ), the lightest hydrocarbon molecule, but it may also contain ethane ( $\text{C}_2\text{H}_6$ ), propane ( $\text{C}_3\text{H}_8$ ), butane ( $\text{C}_4\text{H}_{10}$ ) and other gases in lesser amounts. Combustion of one cubic meter of natural gas yields 38 MJ (10.6 kWh or 36,000 Btu).

**Example 12.7 CLEAN ENERGY**

Natural gas is often touted as the 'clean energy' alternative to coal. Both fuels produce the same amount of CO<sub>2</sub> per mass of carbon burned, but natural gas yields more energy per mass of CO<sub>2</sub> produced.

Natural gas is about 95% methane and coal is about 95% carbon. For simplicity, use 100% carbon and methane as surrogates for coal and natural gas. The balanced chemical reactions and fuel values (from Table 12.1) are



Coal (carbon) combustion releases 44 kg CO<sub>2</sub> for every 12 kg carbon burned, so the energy released is  
(9.61 kWh/kg C) (12 kg C/44 kg CO<sub>2</sub>) = 2.62 kWh released/ kg CO<sub>2</sub> produced


Natural gas (methane) combustion produces 44 kg CO<sub>2</sub> for every 16 kg methane burned, so the energy released is  
(14.66 kWh/kg CH<sub>4</sub>)(16 kg CH<sub>4</sub>/44 kg CO<sub>2</sub>) = 5.33 kWh released/kg CO<sub>2</sub> produced

Natural gas combustion releases about twice the energy per mass CO<sub>2</sub> produced and is, thus, the 'cleaner' of the two. Burning coal also has associated problems with sulfur and particulate emissions as well as disposal of ash (from the 5% or so of coal that is not carbon).

The U.S. EPA estimated that the approximately 6,000 landfills in the U.S. produce an estimated 13–18 billion m<sup>3</sup> (450–650 billion ft<sup>3</sup>) of methane annually.

.....Alcatel-Lucent

www.alcatel-lucent.com/careers



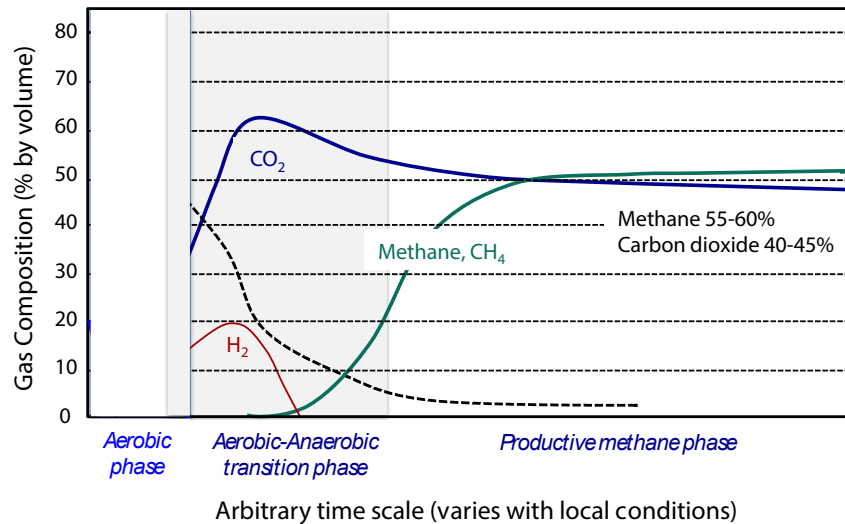
What if  
you could  
build your  
future and  
create the  
future?

One generation's transformation is the next's status quo. In the near future, people may soon think it's strange that devices ever had to be "plugged in." To obtain that status, there needs to be "The Shift".





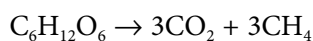
Methane gas has twenty times the global warming potential (GWP) of carbon dioxide, so collecting it for use as fuel is beneficial in terms of energy produced and reduction of green house gases. Just over half of landfill-produced CH<sub>4</sub> is recovered and burned through flaring or electricity generation. The number of landfill gas projects using the methane gas from decomposing refuse went from 399 in 2005 to 594 in 2011 (USEPA).



**Figure 12.2** Conceptual model of the development of methane production in a landfill.

Figure 12.2 is a conceptual model of the development of methane production in a landfill. When the refuse is first placed and covered, the gas within the buried material is essentially air (oxygen and nitrogen). Within a fairly short time the oxygen is consumed and the initial aerobic conditions turn anaerobic, the pH and moisture content become tolerable for the methane forming bacteria and fermentation starts to produce organic acids (acetic, etc.). The economically interesting phase has useful volumes of methane being produced continuously over a number of years. Finally, the organic substrate necessary for methane production is exhausted, the volume of gas produced and the methane content of the gas decline below useful levels. This phase is not shown in Figure 12.2.

A simplified and very approximate reaction for landfill gas production, using C<sub>6</sub>H<sub>12</sub>O<sub>6</sub> as an empirical 'refuse molecule' is



The predicted yield is 3 moles of CO<sub>2</sub> and 3 moles of CH<sub>4</sub>. The mixture is, by volume percent, 50% methane and 50% carbon dioxide. Landfill gas from the productive phase is approximately 50% to 60% methane, with the remainder being mostly carbon dioxide. When the landfill is young or very old, the methane content may be only 10–20%.



The methane makes it a valuable resource and modern practice is to extract it from the landfill and use it. Landfill gas also contains varying amounts of nitrogen, oxygen, water vapor, hydrogen sulfide, and other contaminants.

Fuel	Natural gas	Landfill gas	Catalytic cracker offgas	Steam with hydrocarbon	Hydrogen purge gas
<b>Lowest heating value</b>					
Btu/scf (a)	913	439	132	46.8	354
MJ/Nm <sup>3</sup> (b)	36	17.3	5.2	1.84	13.9
kWh/Nm <sup>3</sup>	129	62.2	18.7	6.63	50.2
Specific gravity	0.59	1.02	0.85	0.65	0.22
scf/1000 Btu	1.10	2.28	7.58	21.4	2.82
Nm <sup>3</sup> /1000 MJ	27.8	57.8	192	543	71.7
Nm <sup>3</sup> /1000 kWh	7.73	16.1	53.4	151	19.9
<b>Combustion products (15% excess air)</b>					
moles/10 <sup>6</sup> Btu	8.5	15.4	15.6	90.4	32.8
moles/MJ	806	1460	14,800	85,700	3,090
moles/kWh	224	405	4,120	23,800	860
<b>Combustion products (mol %)</b>					
CO <sub>2</sub>	8.5	15.4	15.6	4.57	4.49
H <sub>2</sub> O	16.5	15.9	10.5	65.7	24.8
O <sub>2</sub>	2.5	2.3	1.66	1.03	2.37
N <sub>2</sub>	72.5	6.44	72.3	28.7	68.3
Flame temp. (°F)	3,330	3,040	2,870		
Flame temp. (°C)	1830	1670	1580		
<b>Fuel composition (volume %)</b>					
CH <sub>4</sub>	93.4	48.25	1.4	5% mixed hydro-carbons in steam	12.6
CO <sub>2</sub>	0.7	48.25	6.7		5
C <sub>2</sub> H <sub>6</sub> , C <sub>3</sub> H <sub>8</sub> & C <sub>4</sub> H <sub>10</sub>	3.5	--	--		0.97
CO	--	--	23.7		0.42
N <sub>2</sub>	2.4		49.7		81
H <sub>2</sub> O	--	3.5	2.8		

(a) scf = standard cubic feet = 1 ft<sup>3</sup> at 60 °F and 1 atmosphere and 0% relative humidity  
(b) Nm<sup>3</sup> = normal cubic meter = 1 m<sup>3</sup> at 0°C, 1 atmosphere, and 0% relative humidity  
Volumetric conversion factor for gases: 1 Nm<sup>3</sup> = 37.326 scf

**Table 12.5** Fuel value of waste gases

In 1991, the USEPA identified 94 non-methane organic compounds (NMOCs), including toxic chemicals like benzene, toluene, chloroform, vinyl chloride, and carbon tetrachloride. At least 41 of the non-methane organic compounds contain chlorine, fluorine, or bromine. These compounds usually make up less than one percent of landfill gas but they cannot be neglected.

Table 12.5 compares the composition of landfill gas with natural gas and a few other industrial waste gases.

Landfill gas can be managed by flaring (wasting by burning) or it can be used as fuel for boilers, internal combustion engines, gas turbines, or fuel cells. Methane can be converted to methyl alcohol, or it can be cleaned and piped to other industries or into natural gas lines. Hydrogen sulfide ( $H_2S$ ) must be removed prior to most uses so sulfuric acid is not formed during combustion.

**Example 12.8 DIGESTER GAS (METHANE) FOR MICROTURBINE ELECTRICITY GENERATION**

A Wisconsin Department of Natural Resources survey of methane use in wastewater treatment plants reports the following details for the Village of Grafton. Digester gas is to be used in a microturbine that will generate 30 kW at a digester gas feed rate of 13.13 ft<sup>3</sup>/min (0.374 m<sup>3</sup>/min). The microturbine will operate 90 percent of the time and has an O&M cost of \$0.025/kWh. Electric energy is worth \$0.08 kWh and recovered heat energy is worth \$6 per million Btu. Considering only operating costs, calculate the payback time for installing a microturbine.

Total solids to digester = 1,714 kg/d (3,773 lb/d)  
 Volatile solids fraction = 75%  
 Volatile Solids to digestion = 0.75(1,714 kg/d TS) = 1,286 kg/d VS (2,834 lb/d VS)  
 VSS reduction by digestion = 50%  
 VSS Destroyed = (0.5)(1,286 kg/d VS) = 643 kg/d VS destroyed (1,417 lb/d VS destroyed)

Digester gas yield factor = 0.93 m<sup>3</sup>/kg VS destroyed (15 ft<sup>3</sup>/lb VS destroyed)  
 Gas Production = (0.93 m<sup>3</sup>/kg VS destroyed)(643 kg/d VS destroyed) = 598 m<sup>3</sup>/d (21,100 ft<sup>3</sup>/d)  
 Methane production (gas = 70% methane) = (0.7)(598 m<sup>3</sup>/d) = 419 m<sup>3</sup>/d  
 Energy value of methane = (419 m<sup>3</sup>/d)(9.33 kWh/m<sup>3</sup>) = 3,909 kWh/d = 14,070,000 kJ/d (13,340,000 Btu/d)

Microturbine (Capstone C30 Biogas) power generating potential = 30 kW  
 Microturbine electricity generating potential = 720 kWh/d  
 Annual utilization at 90% = (0.9)(24 h/d)(365 d/y) = 7884 h/y (use 7900 h/y)  
 Value of electricity generated at 7,900 h/y and \$0.08/kWh = (30 kW)(7,900 h/y)(\$0.08/kWh) = \$18,960/y (use \$19,000/y)  
 Heat recovered from the microturbine at 25% efficiency = (0.25)(14,070,000 kJ/d) = 3,518,000 kJ/d (3,334,000 Btu/d)  
 Value of heat recovered from the microturbine at 7,900 h/y utilization and \$6/1,000,000 Btu  
 = (3,334,000 Btu/d)(d/24h)(7,900 h/y)(\$6/1,000,000 Btu) = \$6,584/y (use \$6,600/y)

Annual O&M costs of operating a microturbine at \$0.025/kWh = (\$0.025/kWh)(30 kW)(7,900 h/y) = \$5,925/y (use \$5,900)  
 Microturbine purchase and installation = \$140,000  
 Payback period = \$140,000/(\$19,000 + \$6,600 - 5,900) = \$140,000/\$19,700 = 7.1 years.

**Example 12.9 LANDFILL GAS**

Gas will be collected from a landfill that receives the solid waste from a city of 200,000 people. Assuming 900 kg of refuse per year per person, the landfill has been receiving 180,000,000 kg/y, or about 500,000 kg/d. Each kg of municipal refuse put into a landfill yields 0.41 m<sup>3</sup> of landfill gas that is about 50 percent methane and 50 percent carbon dioxide. The heating value of methane is about 50,000 kJ/kg, or 33.6 MJ/m<sup>3</sup> (9.33 kWh/m<sup>3</sup>).

Expected gas production = (500,000 kg/d)(0.41 m<sup>3</sup>/kg) = 205,000 m<sup>3</sup>/day  
 Heating value of methane = 9.33 kWh/m<sup>3</sup>  
 Landfill gas is approximately 50% methane  
 Approximate heating value of the landfill gas = 4.67 kWh/m<sup>3</sup>  
 Heating value of the gas produced is (205,000 m<sup>3</sup>/day)(4.67 kWh/m<sup>3</sup>) = 9.57 x 10<sup>5</sup> kWh/d

Constant gas production increases the pressure within the landfill and causes lateral and vertical gas migration. Migration to the surface adds to the inventory of atmospheric greenhouse gases, which should be prevented. Landfills are capped with an impervious layer to reduce the entry of water. This also reduces the emission of gas.

Lateral gas migration can cause environmental, hygiene, and security problems. Accidents have occurred when gas moved out of the landfill and into nearby buildings and houses. There have been explosions that destroyed property and killed people.

The best way to control gas migration is extraction. The extracted gas needs to be burned in a flare or put to use as a fuel. Figure 12.3 shows the layout of a system for recycling landfill off-gas. Instead of using natural gas, a Dow chemical plant pipes methane from a local landfill to its manufacturing plant in Dalton, GA. The gas is used to generate steam for the manufacture of latex carpet backing. This site is expected to use approximately 169 million MJ (160 billion Btu) per year of landfill gas (the energy equivalent of 5.3 million liters of gasoline (1.4 million gallons)).



**Join the best at  
the Maastricht University  
School of Business and  
Economics!**

**Top master's programmes**

- 33<sup>rd</sup> place Financial Times worldwide ranking: MSc International Business
- 1<sup>st</sup> place: MSc International Business
- 1<sup>st</sup> place: MSc Financial Economics
- 2<sup>nd</sup> place: MSc Management of Learning
- 2<sup>nd</sup> place: MSc Economics
- 2<sup>nd</sup> place: MSc Econometrics and Operations Research
- 2<sup>nd</sup> place: MSc Global Supply Chain Management and Change

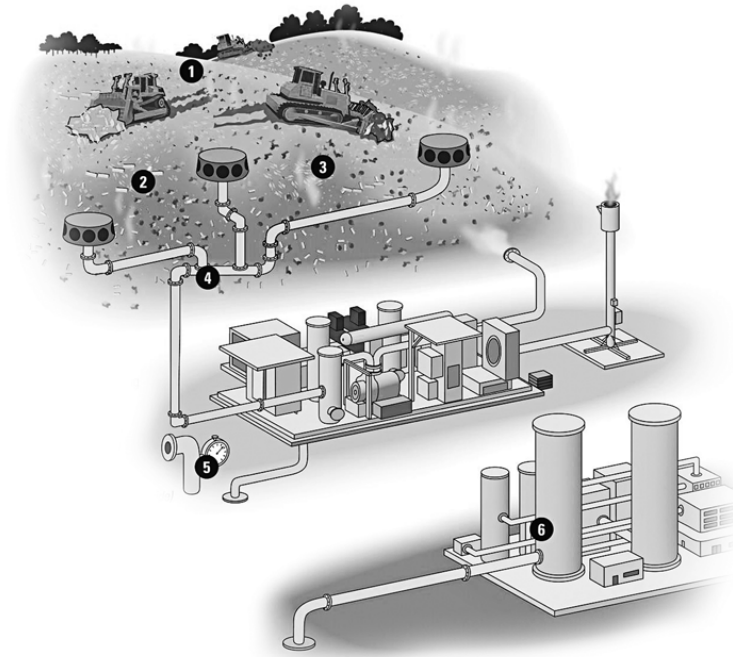
Sources: Keuzegids Master ranking 2013; Elsevier 'Beste Studies' ranking 2012; Financial Times Global Masters in Management ranking 2012

**Maastricht  
University is  
the best specialist  
university in the  
Netherlands  
(Elsevier)**

**Visit us and find out why we are the best!  
Master's Open Day: 22 February 2014**

[www.mastersopenday.nl](http://www.mastersopenday.nl)





**Figure 12.3** Landfill gas is extracted from wells and piped to a processing station where it is cleaned of hydrogen sulfide and other corrosive or harmful compounds and burned to produce heat or electricity. The landfill gas system for energy in Dalton, Georgia is shown in this diagram. (1) Landfill waste is structured. (2) Anaerobic bacteria decompose the municipal solid waste. (3) Methane off-gas is generated. (4) A system of pipes and blowers collects gas and delivers it to a central location. (5) Gas is used as fuel to make steam. (6) Steam is used by the Dow emulsion polymers plant to manufacture latex carpet backing. (Patt & Banholzer, 2009)

## 12.7 Energy Recovery from Anaerobic Sludge Digestion

Wastewater treatment plants use *anaerobic sludge digestion* to stabilize sludge that is highly offensive and unhealthful. Digestion makes the sludge easier to dewater so the volume can be reduced before composting, drying, or spreading on farmland.

An important by-product of the digestion process is biogas, which is 50–70% methane and 30–50% carbon dioxide, with traces of hydrogen sulfide (1–3%), small amounts of nitrogen and hydrogen, and traces other gases (mercaptans, etc.). The gas is used to heat raw sludge as it enters the digester and to maintain the desired internal temperature of the digester, which is 35°C or 55°C, depending on the type of process that is used. Excess gas can be used to heat buildings, to fuel pump or blower engines, or to generate electricity.

The conventional *mesophilic* anaerobic sludge digester (MAD) operates at 35°C with a detention time of 20–30 days and achieves 45–50% volatile solids reduction. Gas production is 0.8–1.1 m<sup>3</sup>/kg of volatile solids destroyed.

*Thermophilic* anaerobic digestion (TAD) at a temperature of 55°C and a detention time of 20 days has been gaining favor over the traditional mesophilic process because it accomplishes more solids destruction, yields more biogas, greatly reduces pathogenic organisms in the sludge, and the digested sludge is more easily dewatered.

TAD and MAD can be combined to create a two-stage digestion process called *temperature-phased anaerobic digestion* (TPAD).

**Example 12.10 ENERGY BALANCE FOR MESOPHILIC ANAEROBIC DIGESTION**

The three digestion systems are compared in Figure 12.4. In each case the digester feed is 1,000 m<sup>3</sup>/d = 1,000 T/d. The volume of the sludge leaving the digester is 1,000 m<sup>3</sup>/d, but the mass is less than 1,000 T/d because some volatile solids are converted to gas.

The sludge is 3% solids by weight and the volatile solids fraction is 0.7, giving 30,000 kg/d of total solids, 21,000 kg/d of volatile solids and 9,000 kg/d of fixed solids. The fixed solids pass through the digesters. The volatile solids are reduced by 40% or 50% as shown in Figure 12.4.

The assumed values for methane production and heating value are

$$\text{Methane production} = 0.7 \text{ m}^3 \text{ CH}_4/\text{kg VS destroyed}$$

$$\text{Lower heating value of methane (CH}_4\text{)} = 0.037 \text{ GJ/m}^3$$

The energy balances for the entering and exiting sludge streams are

$$\text{Sludge heating requirement (GJ/d)} = c_p m_{\text{sludge}} \Delta T_{\text{heating}}$$

$$\text{Heat recovery (GJ/d)} = c_p m_{\text{sludge}} \Delta T_{\text{recovery}}$$

where specific heat capacity of sludge =  $c_p = 0.0042 \text{ GJ/T}\cdot\text{°C}$

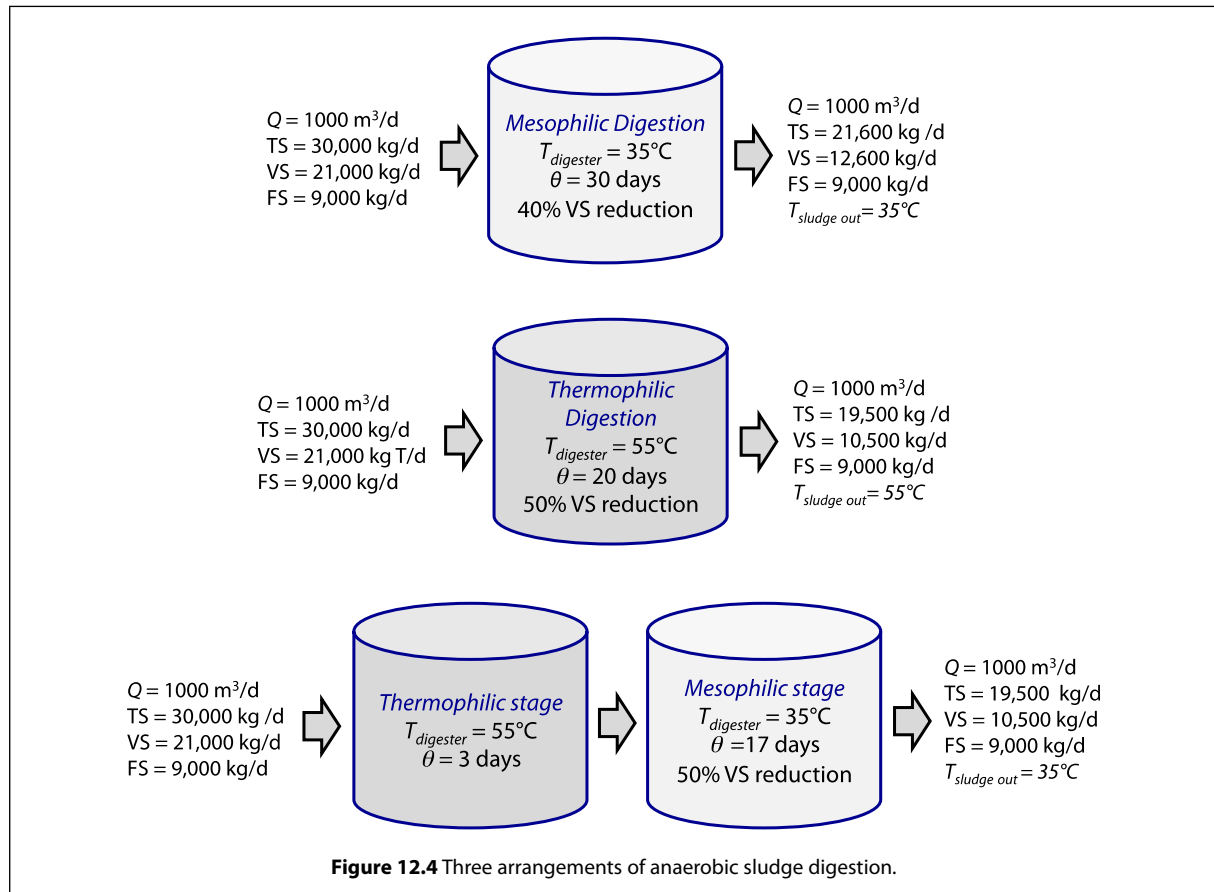
$\Delta T_{\text{heating}}$  applies to the sludge that is heated as it enters the digester

$\Delta T_{\text{recovery}}$  applies to the digested sludge that flows through the heat exchanger

The overall energy balance summarized in Table 12.6 gives the energy value of the biogas, the energy requirement to heat the sludge, the heat energy recovered from the exiting warm sludge, and the heat losses through the walls, floor and cover of the digesters. The recovered energy is used to partially heat the feed sludge. Energy recovered from beneficial use of the methane gas is not included in the heat recovery values.

Energy Balance Component	Mesophilic (MAD)	Thermophilic (TAD)	Two-stage (MAD + TAD)
Energy from biogas	+218	+272	+272
Heat energy recovered	+84	+168	+168
Sludge heating	-105	-189	-189
Heat losses	-16	-28	-18
Overall energy balance	+181	+223	+272

**Table 12.6** Energy Balance comparison for three anaerobic digestion systems.



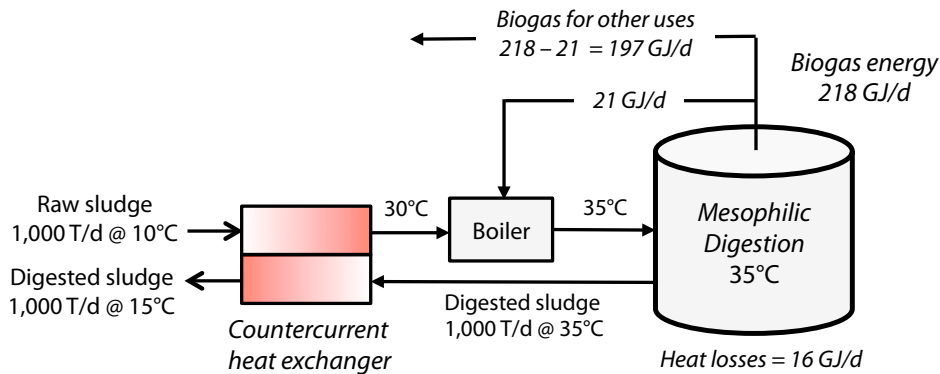
Heat is lost through the floor, cover, and walls of the digester in proportion to these areas and the difference between the ambient temperature of the air and earth and the temperature of the digester contents. They are small in comparison with the quantities of the energy balance so the details can be omitted.

The energy loss from the thermophilic digester is larger than the mesophilic digester because the internal temperature is higher. This is based on an assumption that the wall, floor, and cover construction is the same for both kinds of digesters; that is, no special insulation was added for the thermophilic process.

Local conditions (air temperatures, sludge quality, etc.) do affect the energy balances and may cause the most favorable digestion arrangement to differ from place to place. The air and earth temperatures used were  $10^{\circ}\text{C}$ , which is appropriate for northern regions. Obviously higher temperatures would be more suitable in many parts of the world (Puchajda & Oleszkiewicz 2008).

**Example 12.11 ENERGY BALANCE FOR MESOPHILIC ANAEROBIC DIGESTION**

This example explains the heat recovery energy balance for the mesophilic digester in Figure 12.4. Figure 12.5 shows raw sludge at 10°C heated to 30°C in a countercurrent heat exchanger, using digested sludge at 35°C as the heating fluid. A boiler raises the sludge temperature from 30°C to 35°C. A portion of the 216 GJ/d biogas energy is used in the boiler and 197 GJ/d is available for other uses (e.g. electricity generation)



**Figure 12.5** Energy balance with heat recovery for a mesophilic anaerobic digester.

Total heating requirement ( $T = 10^\circ\text{C}$  to  $T = 35^\circ\text{C}$ )  
 $= (1000 \text{ T/d})(0.0042 \text{ GJ/T}^\circ\text{C})(35^\circ\text{C} - 10^\circ\text{C}) = 105 \text{ GJ/d}$

Energy supplied from boiler ( $T = 30^\circ\text{C}$  to  $T = 35^\circ\text{C}$ )  
 $= (1000 \text{ T/d})(0.0042 \text{ GJ/T}^\circ\text{C})(35^\circ\text{C} - 30^\circ\text{C}) = 21 \text{ GJ/d}$

Energy supplied from heat recovery =  $(1000 \text{ T/d})(0.0042 \text{ GJ/T}^\circ\text{C})(35^\circ\text{C} - 15^\circ\text{C}) = 84 \text{ GJ/d}$

Biogas production =  $(8,400 \text{ kg/d VS destroyed})(0.7 \text{ m}^3 \text{ CH}_4/\text{kg VS destroyed})(0.037 \text{ GJ/m}^3 \text{ CH}_4) = 218 \text{ GJ/d}$

Heat losses = 16 GJ/d

(Note: Heat is lost through the floor, cover, and walls of the digester in proportion to these areas and the difference between the ambient temperature of the air and earth and the temperature of the digester contents. The loss is small in comparison with the quantities of the energy balance so the calculations are omitted.)

Overall energy balance = Energy from biogas + Heat recovered – Sludge heating – Heat Losses  
 $= 218 + 84 - 105 - 16 = +181 \text{ GJ/d}$

## 12.8 Conclusion

Materials once considered wastes are now seen as sources of useful energy. Municipal refuse has been used for fuel in boilers and power plants since the 1970s. Landfill gas is extracted and used for heating and power generation instead of being vented to the atmosphere and waste gas flares. Biogas from anaerobic wastewater treatment processes, in particular municipal and agricultural sludge digesters, allows many treatment facilities to be self-sufficient for heating with excess biogas energy for powering gas engines to run air blowers and pumps.



# 13 Thermal Incineration of Waste Gas

## 13.1 The Design Problem

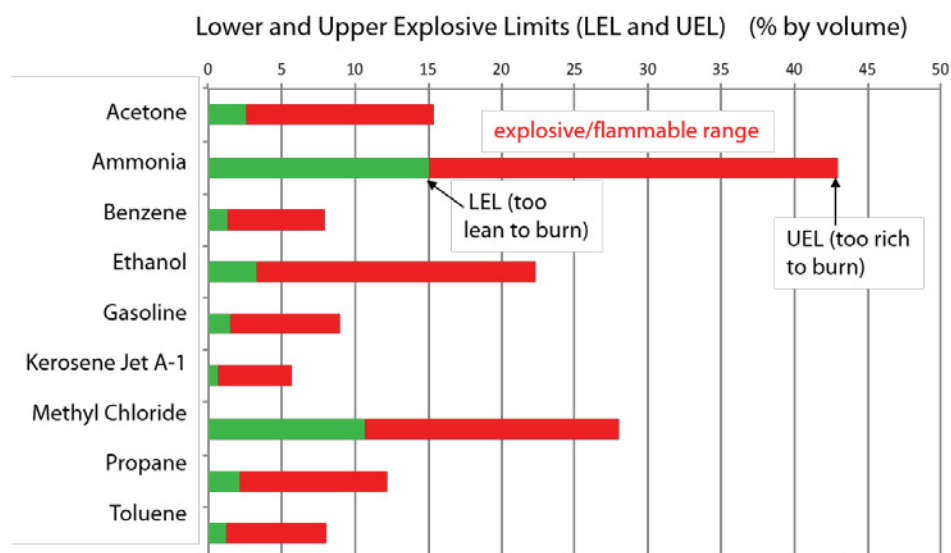
Waste gases that contain solvents and other hazardous organic compounds are regulated under air pollution rules. There are several ways to remove organic chemicals from a gas, but it is also possible to recover energy by burning the organic material.

## 13.2 Safety – The Explosive Limits

The workplace, ventilation systems, and the area around a thermal or catalytic incinerator are at risk of explosion if the concentration of volatile organic chemicals (VOCs) is too high. Before a fire or explosion can occur, fuel and oxygen (air) must exist in certain proportions, along with an ignition source, such as a spark or flame. The ratio of fuel and oxygen that is explosive varies with each combustible gas or vapor.

The minimum concentration of a particular combustible gas or vapor necessary to support its combustion in air is defined as the *Lower Explosive Limit* (LEL). Below this LEL, the mixture is too *lean* to burn because there is not enough fuel value.

The maximum concentration of a gas or vapor that will burn in air is defined as the *Upper Explosive Limit* (UEL). Above this level, the mixture is too *rich* to burn because there is not enough oxygen. The range between the LEL and UEL, shown in Figure 13.1, is the flammable range.



**Figure 13.1** The lower explosive limit (LEL) and upper explosive limit (UEL) form nine common substances. The range between the LEL and the UEL is the explosive/flammable range. Below the LEL the mixture is too lean to burn (not enough fuel value). Above the UEL the mixture is too rich to burn (not enough oxygen).

Waste gases are usually dilute and that makes the LEL the important factor. Safety regulations limit VOC concentrations in an exhaust or vent stream to a fraction, typically 25%, of the Lower Explosive Limit (LEL). If the gas is a mixture of VOCs, the gas with the lowest VOC controls. Table 13.1 gives the limiting concentration for some commonly used VOCs and dusts.

VOC	Butane	Ethane	Ethylene	Acetone	Benzene	Xylene	Toluene
Conc. (ppmv)	4,750	7,500	7,750	7,500	3,500	2,500	3,500
Dust	Polystyrene	Urea	Grain dust	Sugar	Coal	Sewage sludge	Sulfur
Conc. (g/m <sup>3</sup> )	400	125	125	100	60	250	280

**Table 13.1** Volatile Organic Compound (VOC) concentrations corresponding to 25% of Lower Explosive Limits (LELs)

Dust clouds can be flammable and explosive. The lower explosive limits for some flammable dusts are given in Table 13.1. The most violent explosions are produced when the proportion of oxygen present is not far from that which will result in complete combustion. The range of explosive concentrations of a dust cloud is not simply a function of the chemical composition of the dust. The limits vary with the size and shape of the particles in the dust cloud, with smaller sizes generally being more dangerous.

> **Apply now**

REDEFINE YOUR FUTURE  
**AXA GLOBAL GRADUATE  
PROGRAM 2015**

redefining / standards

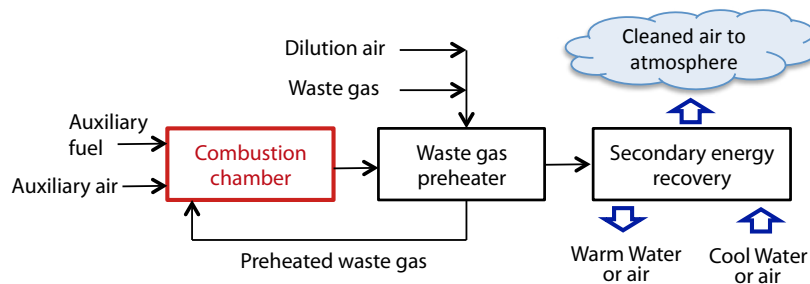


**Example 13.1** LOWER EXPLOSIVE LIMIT OF VOCs

Solvent vapors are drawn from workplace ventilation hoods at concentrations of 7,000 ppmv toluene and 7,500 ppmv acetone. The 25% LELs are 3,500 ppmv for toluene and 7,500 ppmv for acetone. For safety in the ventilation system, the waste air stream must be diluted with fresh air so the toluene concentration is 3,500 ppmv. This will double the volume of contaminated air that must be handled and double the size of the incinerator or any other process that is used to clean the gas. It will also increase the amount of fuel needed to heat the incoming air. The alternative is to somehow reduce the toluene concentration at the source.

### 13.3 Thermal Incineration

*Thermal incineration*, sketched in Figure 13.2, is the combustion of gaseous mixtures in a refractory lined vessel that raises the temperature of the waste gas from its inlet temperature, about 20–35°C (approx. 68–100°F), to the required reactor temperature. The reactor temperature varies from 650–1100°C (1200–2000°F) for different compounds and is determined empirically to get sufficient destruction within the 1–5 second residence time of the combustion chamber.



**Figure 13.2** Thermal incinerator with heat recovery for treating waste gas.

The temperature required in the combustion chamber to get 99.99% destruction with a one second residence time is about 700°C for toluene and about 870°C for methyl chloride. Higher temperatures give faster oxidation and a higher degree of destruction. Longer residence times give a higher degree of destruction. The gas pre-heater is a heat exchanger that heats the inlet gas by recovering energy from the exiting hot gas.

The required volume of the combustion chamber and the residence time are calculated using the actual volumetric flow rate of the combustion gases.

$$V_{chamber} = (T_R)(F_{actual}) \quad \text{and} \quad T_R = V_{chamber} / F_{actual}$$

where  $V_{chamber}$  = volume of the combustion chamber (m<sup>3</sup>)

$T_R$  = residence time (sec)

$F_{actual}$  = actual volumetric flowrate of the waste gas (m<sup>3</sup>/s)

The necessary residence time depends on the chemicals that are incinerated and the operating conditions (temperature, turbulence, etc.). 'Actual' means the volume at the temperature in the combustion chamber. Since volume is proportional to the temperature, the gas volume is very large and the equipment may be surprisingly large to engineers who are accustomed to working with water.

The energy balance for the combustion chamber of a thermal incinerator is

$$\begin{aligned} & \left[ \text{enthalpy of} \right] + \left[ \text{enthalpy of} \right] + \left[ \text{enthalpy of} \right] + \left[ \text{heat released by} \right] + \left[ \text{heat released by} \right] \\ & \text{waste gas} \quad \text{auxiliary fuel} \quad \text{auxiliary air} \quad \text{combustion of waste} \quad \text{combustion of fuel} \\ & = \left[ \text{enthalpy of} \right] + \left[ \text{enthalpy of} \right] + \left[ \text{heat lost} \right] \\ & \text{combustion products} \quad \text{exhaust air} \quad \text{through refractory} \end{aligned}$$

### 13.4 Catalytic Incineration of Waste Gases

*Catalytic incineration*, shown in Figure 13.3, is attractive for treating gaseous emissions when the organic concentration is in the range of 50 ppmv to 10,000 ppmv and the flow is less than 3,000 m<sup>3</sup>/min (about 100,000 scfm). The catalyst increases the reaction rate, which allows the reactor temperature to be reduced.

The waste stream is usually heated with auxiliary fuel, but it can be preheated by heat exchange with the incinerator's effluent gas or some other process stream. The heated gas is then passed through the catalyst bed in which the reaction between the oxygen in the carrier air and the gaseous pollutants takes place.

The typical minimum temperature at the catalyst bed inlet is about 320°C (600 °F) and the temperature at the catalyst bed outlet is 550–650°C, depending on the compounds being burned and the catalyst used.

Efficiency increases as the residence time increases and can reach 98 percent. Typical residence times are 0.05 to 0.25 second.

$$\begin{aligned} T_{R, \text{empty}} &= V/F_{\text{actual}} \\ T_{R, \text{actual}} &= V_{\text{void}}/F_{\text{actual}} \end{aligned}$$

where  $T_{R, \text{empty}}$  = empty-bed residence time (sec)  
 $V$  = volume of the empty catalytic chamber (m<sup>3</sup>)  
 $T_{R, \text{actual}}$  = actual residence time (sec)  
 $V_{\text{void}}$  = void volume of the catalytic bed (m<sup>3</sup>)  
 $F_{\text{actual}}$  = actual volumetric flowrate of the waste gas (m<sup>3</sup>/s)

Gases containing chlorine, sulfur, and certain other atoms can deactivate (poison) noble metal catalysts (e.g., platinum and palladium). Lead, arsenic, and phosphorous should be considered poisons for most oxidation catalysts, though if their concentration is low enough the catalyst deactivation rate is economically acceptable. Particulate matter, including aerosols, can also foul and inactivate a catalyst surface.

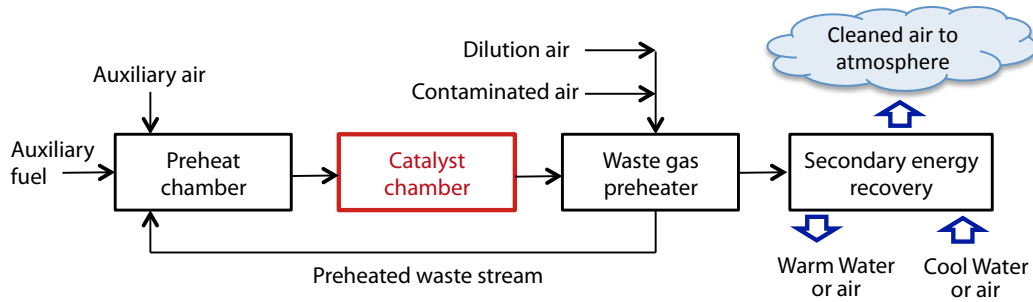


Figure 13.3 Catalytic oxidation with heat recovery for treating waste gas

## 13.5 Case Study – Recovery of Heat from Combustion of Waste Gases

### 13.5.1 The Problem

An industry proposes to destroy a mixture of waste gases in air and a liquid waste using thermal oxidation at 900°C with a 1 second residence time. Heat energy from the combustion will be used to generate steam (Straltz 1993).

The liquid waste is 500 kg/h of pinene ( $C_{10}H_{16}$ ), more commonly known as turpentine. The heating value of this waste is very high.



## Empowering People. Improving Business.

BI Norwegian Business School is one of Europe's largest business schools welcoming more than 20,000 students. Our programmes provide a stimulating and multi-cultural learning environment with an international outlook ultimately providing students with professional skills to meet the increasing needs of businesses.

BI offers four different two-year, full-time Master of Science (MSc) programmes that are taught entirely in English and have been designed to provide professional skills to meet the increasing need of businesses. The MSc programmes provide a stimulating and multi-cultural learning environment to give you the best platform to launch into your career.

- MSc in Business
- MSc in Financial Economics
- MSc in Strategic Marketing Management
- MSc in Leadership and Organisational Psychology

[www.bi.edu/master](http://www.bi.edu/master)

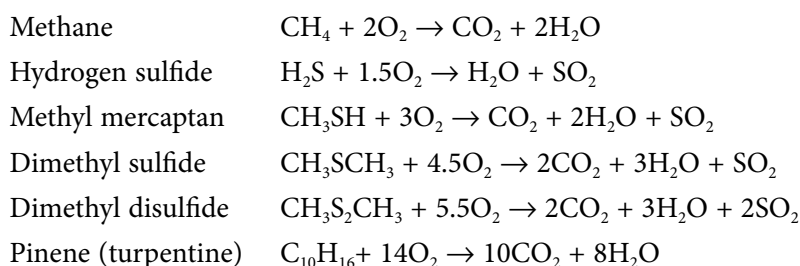


Click on the ad to read more

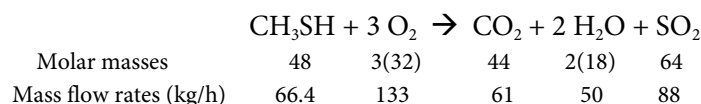
The waste gas is 3,100 normal cubic meters per hour (Nm<sup>3</sup>/h) that contains 2,962 Nm<sup>3</sup>/h of air and 138 Nm<sup>3</sup>/h (243 kg/h) of odorous sulfur compounds and methane. Normal cubic meters per hour (Nm<sup>3</sup>/h) is the volumetric flow rate for gases at standard conditions: T = 0°C and 1 atm (101.325 kPa).

### 13.5.2 Stoichiometric Oxygen Requirement

A material balance on oxygen will determine whether the oxygen in the waste gas stream will meet the stoichiometric demand for combustion. The balanced combustion equations for the five waste gas components and the waste pinene are:



The balanced stoichiometric reaction for the combustion of methyl mercaptan (CH<sub>3</sub>SH) is



The reaction shows that combustion of 48 kg/h of methyl mercaptan consumes 3(32) = 96 kg/h of oxygen and produces 44 kg/h carbon dioxide, 36 kg/h water, and 64 kg/h sulfur dioxide.

The mass flow rate of methyl mercaptan in the waste gas is 66.4 kg/h and the actual quantities, obtained by simple proportion, are 133 kg/h O<sub>2</sub>, 61 kg/h CO<sub>2</sub>, 50 kg/h H<sub>2</sub>O, and 88 kg/h SO<sub>2</sub>. These values are shown below the reaction equation.

Table 13.2 is a summary of the volumetric and mass flow rates for the six waste inputs, the gaseous combustion products, and the stoichiometric oxygen requirements.

The stoichiometric oxygen demands calculated using the balanced chemical reactions are given in Table 13.2. The waste gas stream requires 598 kg/h and the pinene waste demands 1647 kg/h, for a total oxygen requirement of 2,245 kg/h. The air in the waste gas stream contains only 888 kg/h oxygen. An additional 1356 kg/h is needed for stoichiometric combustion of all six compounds and this must come from an auxiliary blower supply.

The calculation of the additional air requirement is also in Table 13.2. In this calculation we assume a volumetric composition of blower air of 79.1% nitrogen and 20.9% oxygen. The corresponding mass flow rates are 76.9% nitrogen and 23.1% oxygen. For example, blower air containing 1361 kg/h oxygen must have a mass flow of  $1361/0.231 = 5890$  kg/h. The stoichiometric airflow contributes no oxygen to the output gas stream because all of the oxygen it carries is consumed by the combustion. The nitrogen output equals the nitrogen input because it is inert.

Normally a small amount of excess air (typically 10%) is added to insure complete oxidation. Before adding this in, the energy balance is checked to see if a larger volume is needed to control the combustion temperature at 900°C

Component	Inputs			Component	Outputs	
	Flow rate (Nm <sup>3</sup> /h)	Flow rate (kg/h)	Oxygen Required (kg/h)		Flow rate (Nm <sup>3</sup> /h)	Flow rate (kg/h)
CH <sub>4</sub>	60	42.8	171.4	CO <sub>2</sub>	1001	1965
H <sub>2</sub> S	4	6.1	8.6	H <sub>2</sub> O	974	782
CH <sub>3</sub> SH	31	66.4	132.8	SO <sub>2</sub>	84	240
CH <sub>3</sub> SCH <sub>3</sub>	37	102.3	237.8			
CH <sub>3</sub> S <sub>2</sub> CH <sub>3</sub>	6	25.2	47.1			
C <sub>10</sub> H <sub>16</sub> (liquid)	82 (a)	500	1647			
Air in Waste Gas (b)	2962	3812				
O <sub>2</sub> in waste gas	619	884		O <sub>2</sub>		0 (a)
N <sub>2</sub> in waste gas	2343	2927		N <sub>2</sub>	2343	2927
Stoichiometric Air from auxiliary blower	4,578	5890				
O <sub>2</sub> in blower air	953	1361		O <sub>2</sub>		0 (b)
N <sub>2</sub> in blower air	3625	4530		N <sub>2</sub>	3625	4530
<b>Total</b>	<b>7,760</b>	<b>10,445</b>	<b>2245</b>			<b>10,444</b>

(a) Volume if pinene existed as a vapor at Normal conditions (0°C and 101.325kPa)

(b) Calculations made assuming air is 20.9% oxygen and 79.1% nitrogen by volume.

**Table 13.2** Material balance to determine stoichiometric oxygen requirements for a thermal incineration process that will burn odorous sulfur compounds and a liquid organic waste (turpentine).



### 13.5.3 The Energy Balance

The heat energy released by the combustion, taking CH<sub>3</sub>SH as an example is

$$\text{Heat energy released (kJ/h)} = (m)(\text{HHV}) = (66.4 \text{ kg/h})(23,518 \text{ kJ/kg}) = 1,562,000 \text{ kJ/h}$$

The heat energy increase in the output gas stream, using CO<sub>2</sub> as an example is

$$\text{Heat energy increase} = m c_p \Delta T = (1965 \text{ kg/h})(1.2728 \text{ kJ/kg}^\circ\text{C})(900^\circ\text{C} - 25^\circ\text{C}) = 2,189,000 \text{ kJ/h}$$

The heat energy yield of the waste gas stream is 6,730,000 kJ/h. The pinene (C<sub>10</sub>H<sub>16</sub>) fuel releases an additional 22,349,000 kJ/h. The combined fuel energy of 29,079,000 kJ/h makes the process self-supporting. Auxiliary fuel will not be needed. In fact, the pinene has so much heating value that careful control of its feed rate will be needed to avoid damage to the equipment.

The very large heat energy release is summarized in Table 13.3.

INPUTS				
Component	Flow rate (Nm <sup>3</sup> /h)	Flow rate (kg/h)	HHV (kJ/kg)	Total heat released (kJ/h)
CH <sub>4</sub>	60	42.8	50,090	2,146,000
H <sub>2</sub> S	4	6.1	15,231	92,000
CH <sub>3</sub> SH	31	66.4	23,518	1,562,000
CH <sub>3</sub> SCH <sub>3</sub>	37	102.4	23,267	2,382,000
CH <sub>3</sub> S <sub>2</sub> CH <sub>3</sub>	6	25.2	21,767	548,000
<b>Waste Gas Subtotal</b>				<b>6,730,000</b>
C <sub>10</sub> H <sub>16</sub> (liquid)	82 <sup>a</sup>	500	44,699	22,349,000
Waste Gas Air	2,962	3,812	NA	NA
Stoichiometric Air	4,578	5,890	NA	NA
<b>Totals</b>	<b>7,760</b>	<b>10,445</b>		<b>29,079,000</b>
OUTPUTS <sup>b</sup>				
Component	Flow Rate (Nm <sup>3</sup> /h)	Flow Rate (kg/h)	C <sub>p</sub> (kJ/kg°C)	Total heat increase (kJ/h)
CO <sub>2</sub>	1001	1,965	1.2728	2,189,000
H <sub>2</sub> O	974	782	2.4032	1,645,000
SO <sub>2</sub>	84	240	0.6155	129,000
O <sub>2</sub>	0	0	1.1095	0
N <sub>2</sub>	5,968	7457	1.2058	7,868,000
<b>Totals</b>	<b>8,027</b>	<b>11,014</b>		<b>11,831,000</b>

(a) volume if pinene existed as a vapor at Normal conditions  
(b) Inlet temperature of gases = 25°C; outlet temperature = 900°C, ΔT = 900-25 = 875°C

**Table 13.3** The preliminary energy balance for the inputs and outputs for a thermal incineration process that will burn odorous sulfur compounds and a liquid organic waste (turpentine).

Inputs				
Component	Flow rate (Nm <sup>3</sup> /h)	Flow rate (kg/h)	HHV (kJ/kg)	Total heat (kJ/h)
CH <sub>4</sub>	60	42.8	50,090	2,146,000
H <sub>2</sub> S	4	6.1	15,231	92,000
CH <sub>3</sub> SH	31	66.4	23,518	1,562,000
CH <sub>3</sub> SCH <sub>3</sub>	37	102.4	23,267	2,382,000
CH <sub>3</sub> S <sub>2</sub> CH <sub>3</sub>	6	25.2	21,767	548,000
C <sub>10</sub> H <sub>16</sub> (liquid)	82 <sup>a</sup>	500	44,699	22,349,000
Waste Gas Air	2,962	3,811	NA	NA
Auxiliary (Stoichiometric) Air	4,578	5,890	NA	NA
Dilution Air	12,943	16,655	NA	NA
<b>Totals</b>	<b>20,703</b>	<b>27,099</b>		<b>29,079,000</b>
Outputs <sup>b</sup>				
Component	Flow Rate (Nm <sup>3</sup> /h)	Flow Rate (kg/h)	c <sub>p</sub> (kJ/kg-°C)	Total Heat (kJ/h)
CO <sub>2</sub>	1001	1965	1.2728	2,189,000
H <sub>2</sub> O	974	782	2.4032	1,645,000
SO <sub>2</sub>	84	240	0.6155	129,000
O <sub>2</sub>	2,694	3,847	1.1095	3,735,000
N <sub>2</sub>	17,522	20,265	1.2058	21,381,000
<b>Totals</b>	<b>20,704</b>	<b>27,099</b>		<b>29,079,000</b>

(a) volume if pinene existed as a vapor at Normal conditions  
(b) Inlet temperature of gases = 25°C; outlet temperature = 900°C,  $\Delta T = 900 - 25 = 875^\circ\text{C}$

**Table 13.4** Revised energy and material balance for the inputs and outputs for a thermal incineration process that will burn odorous sulfur compounds and a liquid organic waste (turpentine).

There is more heat energy released in the inputs than is carried away by 900°C exhaust gases: (29,079,000 – 11,831,000 = 17,248,000 kJ/h). Dilution air must be added to the input stream to carry away the extra heat energy. This will protect the equipment from overheating.

The mass flow of dilution air required to maintain the 900°C exhaust temperature is

$$\begin{aligned}
 \text{Dilution air (kg/h)} &= Q/c_p \Delta T \\
 &= (17,248,000 \text{ kJ/h}) / [(1.1836 \text{ kJ/kg}^\circ\text{C})(900^\circ\text{C} - 25^\circ\text{C})] \\
 &= 16,655 \text{ kg/h}
 \end{aligned}$$

The revised energy and material balances with the excess air added are shown in Table 13.4

A fraction of the approximately 29,000MJ/h of energy generated in this combustion will be used to preheat the waste gas, as shown in Figure 13.3, and some can be used to generate steam and/or heat process flow streams for beneficial use elsewhere in the industrial plant.

#### 13.5.4 Combustion Chamber Volume

The volume of the combustion chamber is calculated using the actual volumetric gas flowrate through the combustion chamber. The combustion reaction is extremely fast and the gas temperature everywhere in the combustion chamber is 900°C. Therefore the actual gas flow through the incinerator is the total rate of carbon dioxide, water vapor, sulfur dioxide gas, oxygen and nitrogen, which is 20,989 Nm<sup>3</sup>/h = 350 Nm<sup>3</sup>/min = 5.83 Nm<sup>3</sup>/s

The conversion from standard conditions ( $T = 0^\circ\text{C} = 273\text{K}$  and 1 atm) to actual conditions (900°C and 1.2 atm) is

$$F_{actual} = F_s \frac{P_s T_a}{P_a T_s}$$

where  $F_{actual}$  = actual volumetric flow rate (m<sup>3</sup>/s)

$T$  = temperature (K = 273 + °C)

$P$  = pressure (atm)

Subscripts  $a$  and  $s$  indicate actual and standard conditions.

## Need help with your dissertation?

Get in-depth feedback & advice from experts in your topic area. Find out what you can do to improve the quality of your dissertation!

Get Help Now



Go to [www.helpmyassignment.co.uk](http://www.helpmyassignment.co.uk) for more info



Helpmyassignment

The actual volume for  $P_a = 1.2$  atm is

$$F_{actual} = F_s \frac{P_s T_a}{P_a T_s} = (5.83 \text{ m}^3/\text{s}) \frac{(1 \text{ atm})(1173 \text{ K})}{(1.2 \text{ atm})(273 \text{ K})} = 20.9 \text{ m}^3/\text{s}$$

The required volume of the thermal oxidizer chamber for a residence time of  $T_R = 1$  second is

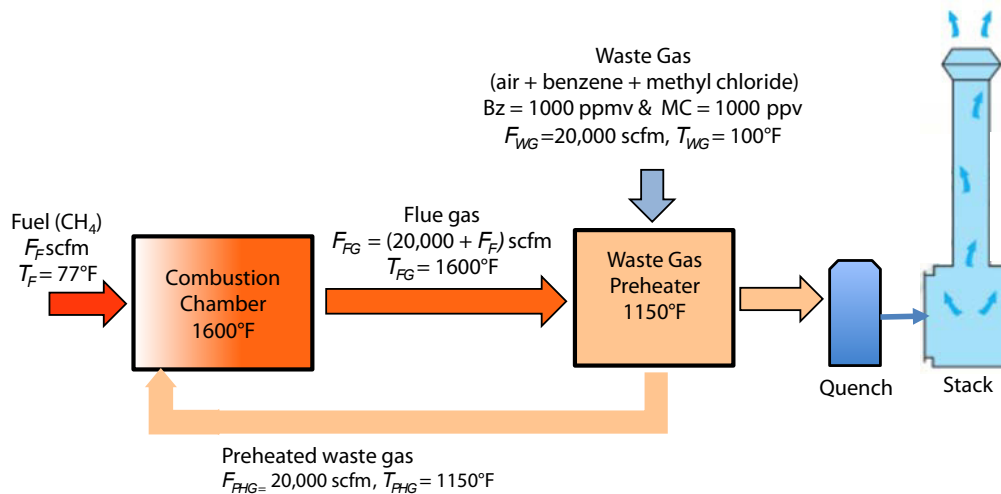
$$V = (20.9 \text{ m}^3/\text{s})(1 \text{ s}) = 20.9 \text{ m}^3$$

## 13.6 Case Study – Energy Balance on a Regenerative Thermal Oxidizer

### 13.6.1 The Problem

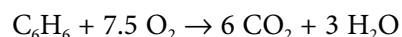
Thermal oxidation will be investigated as a means of meeting a requirement of 98% volatile organic chemical destruction of a 20,000 scfm waste gas flow (standard cubic feet per minute; standard conditions are 77°F and 1 atm). The waste gas contains two volatile organic chemicals: 1000 ppmv benzene (BZ) and 1000 ppmv methyl chloride (MC).

The combustion chamber exhausts into a waste gas preheater so energy can be recovered. The desired thermal energy recovery efficiency is 70%. Figure 13.4 shows some of the known data and the calculated preheater temperature of 1150°F.

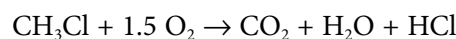


**Figure 13.4** Thermal oxidation with a waste gas preheater for the destruction of benzene and methyl chloride.

Benzene is a hydrocarbon,  $\text{C}_6\text{H}_6$ , and the combustion products are carbon dioxide and water



Methyl chloride (also known as chloromethane) contains a chloride atom and hydrochloric acid vapor will be formed during combustion.



The lower explosive limits are  $LEL_{BZ} = 14,000$  ppmv and  $LEL_{MC} = 82,500$  ppmv. The VOC concentrations of 1000 ppmv do not present any risk of explosion or accidental fires in the ventilation system.

The concentration of benzene and methyl chloride are both 1,000 ppmv. The volume fractions are both 0.1%.

$$\text{volume fraction} = 100(1000 \text{ volumes of Benzene}) / (1,000,000 \text{ volumes of gas}) = 0.1\%$$

The gas composition is

$$\text{Volume fractions: } \quad 0.1\% \text{ benzene} \quad 0.1\% \text{ methyl chloride} \quad 99.8\% \text{ air}$$

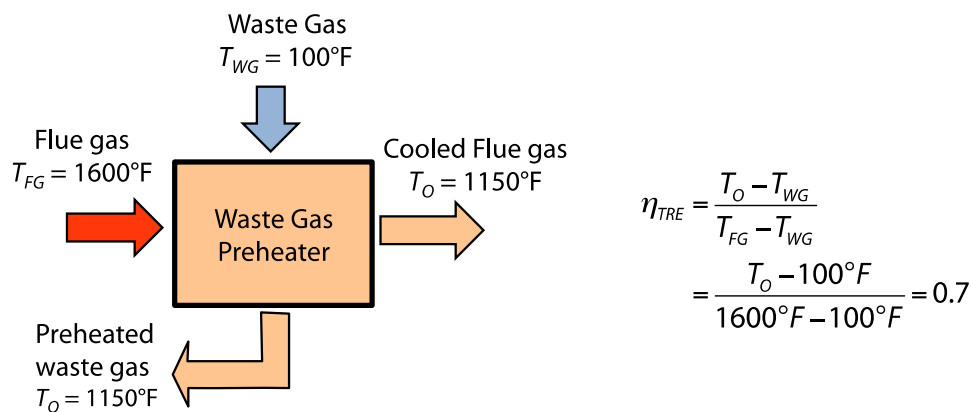
The heating values are 3,475 Btu/scf benzene and 705 Btu/scf methyl chloride.

Thus the heating value of the waste gas is  $(3,475 + 705)(0.001) = 4.18$  Btu/scf

Methane ( $CH_4$ ) will be used as an auxiliary fuel. It has a heating value of 877.3 Btu/scf. The amount will be calculated by making an energy balance on the combustion chamber.

### 13.6.2 The Thermal Recovery Efficiency

The energy balance, shown in Figure 13.5, defines the *thermal recovery efficiency* ( $TRE$ ) and shows that the preheater exit temperature of  $1150^\circ F$  will give the desired 70% efficiency. The temperature in the preheater cannot rise too close to the ignition temperature and it cannot drop below the acid dew point.



**Figure 13.5** Energy balance on the waste gas heat exchanger defines the *thermal recovery efficiency*

The thermal recovery efficiency of the heat transfer unit (the preheater) is

$$\eta_{TRE} = \frac{\text{Actual heat transferred}}{\text{Maximum possible heat transfer @ 100\% efficiency}}$$

The maximum possible heat transfer at 100% efficiency would be when the exiting flue gas (being cooled) and the exiting waste gas (being heated) reach the same temperature. This condition is physically impossible to achieve. It is, however, a convenient simplification for making the calculation and Figure 13.5 shows the cooled flue gas and the preheated waste gas with the same temperature of 1150°F.

The actual heat transfer to the waste gas is:

$$Q_{actual} = \rho_{WG} F_{WG} c_{p,WG} (T_O - T_{WG})$$

The maximum possible heat transfer is:

$$Q_{max\ possible} = \rho_{FG} F_{FG} c_{p,FG} (T_{FG} - T_{WG})$$

where  $\rho$  = gas density (lb/scf)

$F$  = gas volumetric flowrate (scfm)

$c_p$  = specific heat of the gas (Btu/lb°F)

$T_O$  = temperature of gas output exiting the heat exchanger (°F)

$T$  = gas temperature (°F)

Subscripts indicate waste gas (WG) and flue gas (FG)

The density, specific heat and flow rate are assumed equal for the waste gas and flue gas because both are 99.8% air (i.e. the presence of the other gases is negligible).

**Brain power**

By 2020, wind could provide one-tenth of our planet's electricity needs. Already today, SKF's innovative know-how is crucial to running a large proportion of the world's wind turbines.

Up to 25 % of the generating costs relate to maintenance. These can be reduced dramatically thanks to our systems for on-line condition monitoring and automatic lubrication. We help make it more economical to create cleaner, cheaper energy out of thin air.

By sharing our experience, expertise, and creativity, industries can boost performance beyond expectations. Therefore we need the best employees who can meet this challenge!

The Power of Knowledge Engineering

Plug into The Power of Knowledge Engineering.  
Visit us at [www.skf.com/knowledge](http://www.skf.com/knowledge)

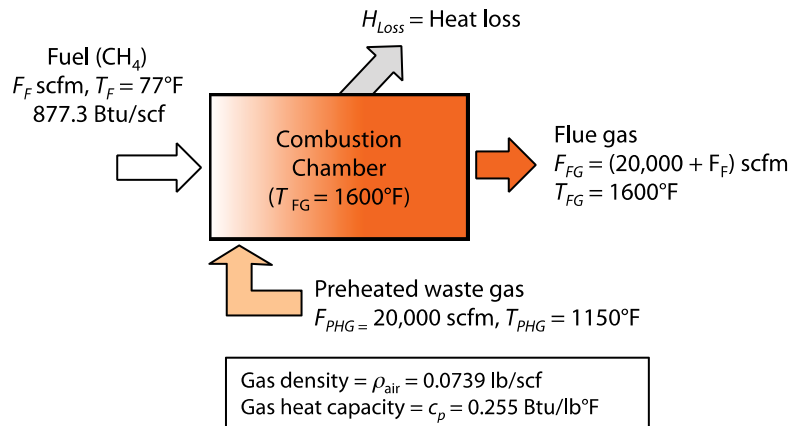
**SKF**

For the desired thermal recovery efficiency of 70% ( $\eta_{TRE} = 0.7$ )

$$\eta_{TRE} = \frac{Q_{actual}}{Q_{max\ possible}} = \frac{\rho_{WG} F_{WG} c_{p,WG} (T_O - T_{WG})}{\rho_{FG} F_{FG} c_{p,FG} (T_{FG} - T_{WG})} = \frac{(T_O - T_{WG})}{(T_{FG} - T_{WG})} = \frac{T_O - 100^\circ F}{1600^\circ F - 100^\circ F} = 0.7$$

and  $T_O = 1150^\circ F$

### 13.6.3 Overall Energy Balance and the Methane Fuel Requirement



**Figure 13.6** Definition diagram for the energy balance on the combustion chamber to calculate the fuel requirement.  $F$  denotes a volumetric flow rate (scfm).

The overall energy balance for the combustion chamber is

$$H_{WG} + H_{Fuel} = Q_{FG} + H_{Loss}$$

where  $Q_{FG}$  = sensible heat flow in the flue gas (Btu/min)

$H_{WG}$  = heat supplied by combustion of benzene and methyl chloride (Btu/min)

$H_{Fuel}$  = heat supplied by the methane fuel (Btu/min)

Subscripts indicate waste gas (WG), flue gas (FG), and fuel (F)

The heat loss ( $H_{Loss}$ ) is assumed as 10% of the heat energy in the combustion chamber flue gas, so the energy balance simplifies to

$$H_{WG} + H_{Fuel} = 1.1Q_{FG}$$

The quantities are

$$H_{WG} = (20,000 \text{ scfm})(4.18 \text{ Btu/scf}) = 83,600 \text{ Btu/min}$$

$$H_{Fuel} = (F_{Fuel} \text{ scfm})(877.3 \text{ Btu/scf}) = 877.3F_{Fuel} \text{ Btu/min}$$

$$\begin{aligned} Q_{FG} &= (20,000)(0.0739 \text{ lb/scf})(0.255 \text{ Btu/lb}^\circ F)(1600^\circ F - 1150^\circ F) \\ &\quad + (F_{Fuel})(0.0739 \text{ lb/scf})(0.255 \text{ Btu/lb}^\circ F)(1600^\circ F - 77^\circ F) \\ &= 169,600 + 28.7F_{Fuel} \end{aligned}$$

$$H_{Loss} = 0.1Q_{FG} = 16,960 + 2.87F_{Fuel}$$

where  $F_{Fuel}$  = volumetric flow rate (scfm) of methane and other variables are as defined above.



These values are used in the energy balance equation

$$H_{WG} + H_{Fuel} = Q_{FG} + H_{Loss}$$

$$83,600 + 877.3F_{Fuel} = 169,600 + 28.7F_{Fuel} + 16,960 + 2.87F_{Fuel}$$

$$F_{Fuel} = 102,960/845.7 = 122 \text{ scfm}$$

Without heat recovery about five times more methane fuel would need to be added to raise the temperature of the waste gas from 100°F to 1600°F. The reader may wish to calculate the savings as a practice exercise.

### 13.6.4 Power and Electricity Costs

The power needed for the fan to move the gas through the incinerator is

$$\text{Power}_{fan} (\text{kW}) = \frac{1.17 \times 10^{-4} F_{WG} \Delta P}{\eta}$$

where  $F_{WG}$  is the flow rate (acfm) of the waste gas input to the incinerator  
 $\Delta P$  is the pressure drop (inches of water) through the system  
 $\eta$  is the combined efficiency of the motor and fan

Typically  $\eta = 0.4\text{--}0.7$ . The total pressure drop depends on the equipment elements and the details of the installation.

What do you want to do?

No matter what you want out of your future career, an employer with a broad range of operations in a load of countries will always be the ticket. Working within the Volvo Group means more than 100,000 friends and colleagues in more than 185 countries all over the world. We offer graduates great career opportunities – check out the Career section at our web site [www.volvogroup.com](http://www.volvogroup.com). We look forward to getting to know you!

**VOLVO**  
 AB Volvo (publ)  
[www.volvogroup.com](http://www.volvogroup.com)

VOLVO TRUCKS | RENAULT TRUCKS | MACK TRUCKS | VOLVO BUSES | VOLVO CONSTRUCTION EQUIPMENT | VOLVO PENTA | VOLVO AERO | VOLVO IT  
 VOLVO FINANCIAL SERVICES | VOLVO 3P | VOLVO POWERTRAIN | VOLVO PARTS | VOLVO TECHNOLOGY | VOLVO LOGISTICS | BUSINESS AREA ASIA



**Example 13.2 POWER REQUIREMENT AND ELECTRICITY COST**

Calculate the power requirement of fan that will move  $F_{WG} = 30,000$  acfm through an incinerator system that has a pressure drop of 19 inches of water. The efficiency is 60%.

$$\text{Power}_{\text{fan}} (\text{kW}) = \frac{1.17 \times 10^{-4} (30,000 \text{ acfm})(19 \text{ inches water})}{0.6} = 111.1 \text{ kW}$$

The cost of electricity, assuming 8,000 hours of operation per year and a cost of \$0.07/kWh is

$$\text{Electricity cost } (\$/\text{yr}) = (111.1 \text{ kW})(8,000 \text{ h/yr})(\$0.07 \text{ kWh}) = \$62,200$$

13.6.5 A Preliminary Cost Estimate

These design calculations are sufficient for making preliminary cost estimates in the early stages of a project evaluation. The accuracy of these estimates is  $\pm 30\%$ . Preliminary cost estimates start with the purchased equipment costs (EC) of the major equipment, in this case a recuperative thermal incinerator. Other costs are estimated as percentages of the EC.

**Example 13.3 ECONOMY OF SCALE**

The cost of two units of different capacities can be compared using

$$\frac{C_A}{C_B} = \left( \frac{F_A}{F_B} \right)^{0.25}$$

The exponent (0.25) is a measure of the economy of scale. It is the slope of the line in the log-log graph, Figure 13.7.

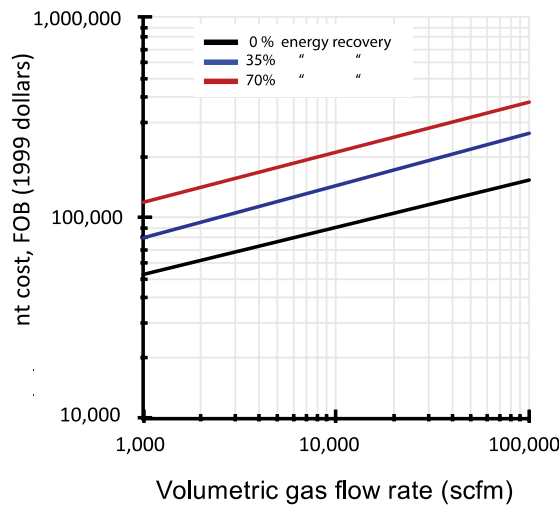
For  $\frac{F_A}{F_B} = 2$        $\frac{C_A}{C_B} = 2^{0.25} = 1.19$

The economy-of-scale for this equipment is impressive. Doubling the size of the unit causes a modest (<20%) increase in the cost.

The cost estimating equations given below for recuperative thermal incinerator equipment (Vatavuk 2002) were used to make Figure 13.7. The cost estimates are in 1999 US dollars.

$$\begin{aligned} EC_{TRE=0\%} &= 10,294 F^{0.25} \\ EC_{TRE=35\%} &= 17,056 F^{0.25} \\ EC_{TRE=70\%} &= 21,342 F^{0.25} \end{aligned}$$

where  $F$  = capacity measured in standard cubic feet per minute (scfm)  
 $EC$  = estimated equipment cost (1999 US\$)  
 $TRE$  = thermal recovery efficiency (%)



**Figure 13.7** The capital cost (in 1999 US\$) of thermal incinerators, with and without heat recovery. The cost does not include installation. FOB (Free on board) means the equipment is loaded for shipment but shipping cost is not included.

The purchased equipment cost (PEC) for a capacity of 20,000 scfm is  $EC = \$254,000$ . The other costs in Table 13.5 come from this value. The total cost, not including site preparation or new building, is \$662,400.

**gaiteye**  
Challenge the way we run

EXPERIENCE THE POWER OF FULL ENGAGEMENT...

RUN FASTER.  
RUN LONGER..  
RUN EASIER...

READ MORE & PRE-ORDER TODAY  
[WWW.GAITEYE.COM](http://WWW.GAITEYE.COM)

Cost Item	Factor	Cost (1999 \$)
<b>Direct Costs</b>		
<b>Purchased Equipment Costs (PEC)</b>		
• Thermal incinerator equipment cost (EC)	From Figure 13.7	\$254,000
• Auxiliary equipment	0.4 EC	\$101,600
• Instrumentation	0.1 EC	\$25,400
• Sales taxes & freight	<u>0.1 EC</u>	<u>\$25,400</u>
<b>Purchased Equipment Cost, PEC</b>	<b>1.6 EC</b>	<b>\$406,400</b>
<b>Direct Installation Costs (DIC)</b>		
• Foundations & supports	0.08 PEC	\$32,500
• Handling & erection	0.14 PEC	\$56,900
• Electrical	0.04 PEC	\$16,300
Piping & other	<u>0.06 PEC</u>	<u>\$24,400</u>
<b>Direct Installation Costs (DIC)</b>	<b>0.32 PEC</b>	<b>\$130,100</b>
<b>Total Direct Costs, DC</b>	<b>DC = PEC + DIC</b>	<b>\$536,500</b>
<b>Indirect Costs (IC)</b>		
• Engineering	0.10 PEC	\$40,600
• Construction and field expenses	0.05 PEC	\$20,300
• Contractor fees	0.10 PEC	\$40,600
• Start-up & performance test	0.03 PEC	\$12,200
• Contingencies	<u>0.03 PEC</u>	<u>\$12,200</u>
<b>Total Indirect Costs, IC</b>	<b>0.31 PEC</b>	<b>\$125,900</b>
<b>Total Capital Investment = DC + IC</b>		<b>\$662,400</b>

**Table 13.5** Preliminary cost estimate for a thermal incineration. Amounts are 1999 US dollars (Vatavuk 2002). Cost does not include site preparation or buildings.

## 13.7 Conclusion

Ventilation air and waste gases from industries and a variety of manufacturing processes contain regulated organic chemicals, usually solvents. The first option is source control – change the manufacturing process to eliminate the emission or to substitute a non-toxic chemical or an unregulated solvent. When the contaminated air/gas stream cannot be eliminated at the source, the contaminant must be removed or destroyed.

Removal of organic chemicals can be accomplished by adsorption, for example onto activated carbon. This may allow for solvents to be recovered for sale or reuse.

Destruction is usually accomplished by incineration or catalytic oxidation. This removes the option of recovering solvent or some other organic chemicals, but instead heat energy can be recovered.



This e-book  
*is made with*  
**SetaPDF**

**SETASIGN**

PDF components for **PHP** developers

[www.setasign.com](http://www.setasign.com)

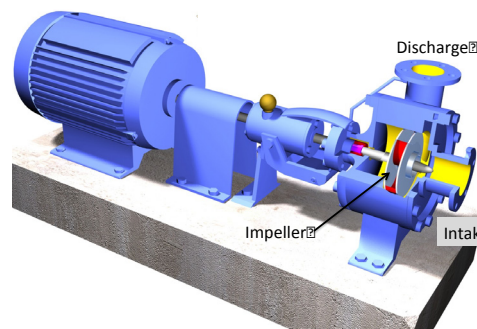


# 14 Energy Consumption by Pumping

## 14.1 Water and Energy

Water and energy share a critical interdependency. It takes energy to treat, pump and prepare water for end-use, and water is needed to produce electricity and liquid fuels. Success in conserving water almost always conserves energy, and vice versa.

Pumping systems account for nearly 20% of the world's energy use by electric motors and 25-50% of the total electrical usage in certain industrial facilities. Energy used in pumping, treating, delivering, and preparing water for end uses accounts for about 13% of the U.S. total annual energy consumption. Each pump installation will provide an opportunity to either waste energy or save energy.



**Figure 14.1** Single-stage radial centrifugal pump (Source: Wikipedia)

There are many kinds of pumps (Wikipedia has an animated catalog of pump types.) Most pumps used for water are *centrifugal pumps*, such as shown in Figure 14.1. The cutaway shows an impeller (the disk with red vanes) that will be rotated by the drive motor. The quantity of water discharged depends on the diameter of the impeller (the size of an impeller in a pump can be changed), the speed of rotation, and the shape of the impeller.

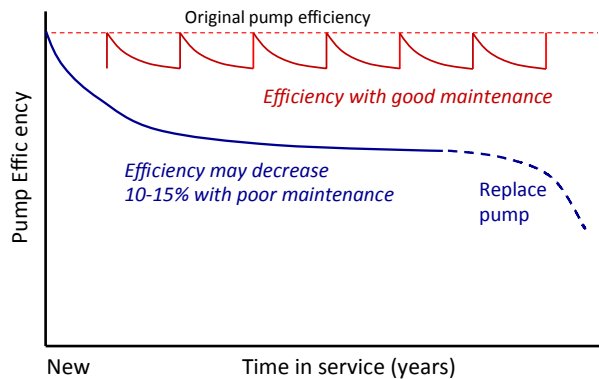
## 14.2 Pump Efficiency

The efficiency of any machine refers to how well it can convert one form of energy into another. The efficiency is 50% if one unit of energy supplied to a machine yields an output of one-half unit.

Pumping systems involve two extremely simple, yet efficient machines – the centrifugal pump and the AC induction motor. The centrifugal pump converts mechanical energy into hydraulic energy (flow, velocity, and pressure) and the AC motor converts electrical energy into mechanical energy. Many medium and larger centrifugal pumps operate at 75–90% efficiency and even smaller ones usually fall into the 50–70% range. Large AC motors, on the other hand, can approach an efficiency of 97% and any motor, five hp (4 kW) and above, can be designed to break the 90% barrier.

Most pumps will operate at peak efficiency only intermittently because the discharge is frequently changing, and the pipe networks change over time either by aging or by intentional modifications. The pumps themselves may be poorly maintained so they drift away from optimal performance.

A well-maintained centrifugal pump can provide excellent service for 30 years. A pump that is abused or poorly maintained will need replacement in a much shorter time, as suggested by Figure 14.2.



**Figure 14.2** A well maintained centrifugal pump will have a long life. Poor maintenance will lead to premature replacement.

### 14.3 The Pump Curve and Efficiency Curve

Pressure is the resistance a pump works against. It is measured as kPa, kg/m<sup>2</sup>, or lb/ft<sup>2</sup>.

$$\text{Pressure} = (\text{water density}) (\text{water depth})$$

$$P = \rho d$$

A water depth of 2 m is equivalent to

$$P \text{ (kg/m}^2\text{)} = (1000 \text{ kg/m}^3)(2 \text{ m}) = 2000 \text{ kg/m}^2 = 0.2 \text{ kg/cm}^2$$

A water depth of 2 ft is equivalent to

$$P \text{ (lb/ft}^2\text{)} = (62.4 \text{ lb/ft}^3)(2 \text{ ft}) = 124.8 \text{ lb/ft}^2 = 0.867 \text{ lb/in}^2$$



Another common term for this resistance – curious term called *head* ( $h$ ) – needs to be defined. *Head* is pressure expressed as an equivalent water depth and it is measured in meters or feet. This is convenient because the main job of a pump is to lift water, and it is natural to think of the lift as so many meters or feet.

*Pressure* and *head* measure the same quantity, but in different units; they are interchangeable.

Other equivalencies are:

1 atmosphere of pressure =  $14.7 \text{ lb/in}^2 = 2,116 \text{ lb/ft}^2 = 10,330 \text{ kg/m}^2 = 101.35 \text{ kPa}$

1 atmosphere of pressure =  $33.9 \text{ ft} = 10.33 \text{ m}$  of water

A water depth of  $1 \text{ m} = 1,000 \text{ kg/m}^2 = 9.807 \text{ kPa}$

A water depth of  $1 \text{ foot} = 62.4 \text{ lb/ft}^2 = 0.433 \text{ lb/in}^2$  (psi)

The *pump curve* and the *efficiency curve* are characteristics of the pump: the type of pump, the diameter of the pump impellor, and the speed of rotation. Figure 14.3 is a pump curve for a centrifugal pump. As the operating head, or the pumping resistance, increases the pump discharge decreases.



www.sylvania.com

We do not reinvent  
the wheel we reinvent  
light.

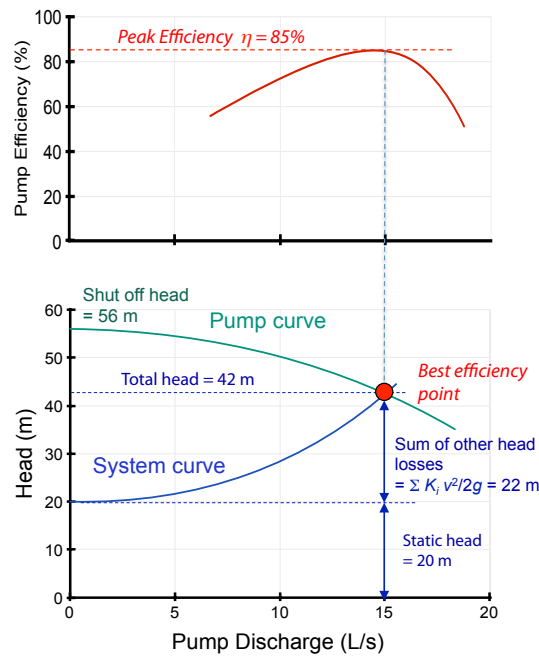
Fascinating lighting offers an infinite spectrum of possibilities: Innovative technologies and new markets provide both opportunities and challenges. An environment in which your expertise is in high demand. Enjoy the supportive working atmosphere within our global group and benefit from international career paths. Implement sustainable ideas in close cooperation with other specialists and contribute to influencing our future. Come and join us in reinventing light every day.

Light is OSRAM

OSRAM  
SYLVANIA



Click on the ad to read more



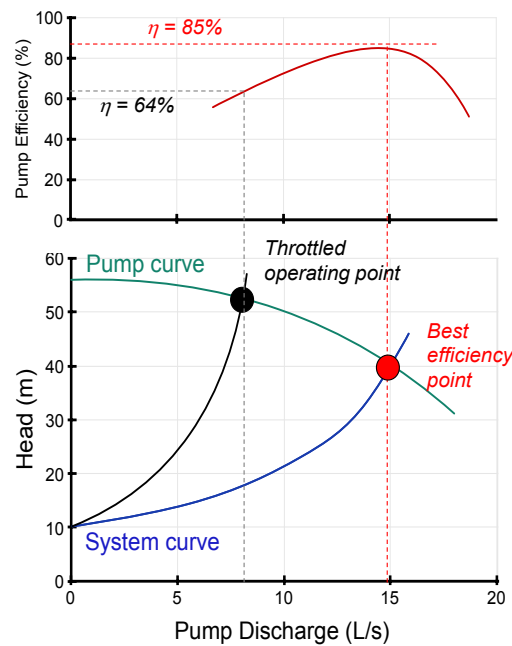
**Figure 14.3** The pump head-discharge curve with the efficiency curve (top). These are determined by type of pump, pump speed, and type of pump impeller. The system curve is quadratic with flow. The duty point is at the intersection of the curves. If the duty point is at the peak efficiency it is called the best efficiency point. This curve shows a correspondence of the duty point and best efficiency point (85% efficiency) at flow  $Q = 15$  L/s and total head  $h = 42$  m.

The system curve shows the operating head as a function of the discharge. It is defined by the system of piping, valves, filters, heat exchangers, and other devices the through which the fluid must be pumped. The upward curving shape is because the friction resistance increases as the flow increases.

The height to which a fluid must be lifted is called the *static head*. This is the value of the system curve at  $Q = 0$ . If a pipe from the pump discharge were directed straight up the pump could lift the fluid to some height and no higher. That height is the *shut-off head* – the head at a flow of zero.

The resistance to flow caused by the pipe, fittings, and devices is proportional to the *kinetic energy* of the fluid,  $v^2/2g$ . For a fixed pipe diameter ( $D$ ), the velocity increases with the discharge:  $Q = vA = v\pi D^2/4$  and  $v = 4Q/\pi D^2$ . When this quantity is expressed in meters (or feet) it is called the *velocity head*.

The *duty point* is at the intersection of the pump curve and the system curve. If the duty point is at the peak efficiency it is called the best efficiency point. This curve shows a correspondence of the duty point and best efficiency point at flow  $Q = 15$  L/s and total head  $H = 42$  m. The design flow is usually at the best efficiency point, although the flow under actual operation may be more or less.



**Figure 14.4** If the discharge is shifted from 15 L/s to 8 L/s the pump efficiency drops from 85% to 64%.

Operating away from the best efficiency point increases operating costs and stress on the pump. Figure 14.4 shows that the pump efficiency drops from 85% to 64% when the discharge shifts from 15 L/s to 8 L/s. This shift could be caused by closing a valve to reduce the flow, or it might be caused by blockage or severe corrosion in a pipe.

If the normal operating point were to be changed from 15 L/s to 8 L/s, the pump should be changed, the pump impeller should be changed, or the operating speed should be changed. The reasons go beyond the efficiency of energy use. Continuous running below the best efficiency point will reduce the life of bearings, seals, and impellers. (Running above the best efficiency point carries similar risks to the equipment.)

A variable speed pump might be a better solution when the discharge needs to fluctuate to meet changing conditions. Changing the speed essentially produces a new pump curve with a higher efficiency. Another possibility is to install two pumps of different capacities so each could operate at its peak efficiency.

### 14.4 Power Requirements

The power required depends on the efficiency of the drive motor and the pump. The power delivered by the pump to the fluid is

$$\begin{aligned}
 \text{Power in horsepower } P_o &= \rho g H Q / 550 \\
 &= 32.2 \rho H Q / 550 \\
 \text{Power in kW } P_o &= 0.0437 \rho H Q \quad (1 \text{ kW} = 0.7457 \text{ hp}) \\
 \text{Power in kW } P_o &= \rho g H Q / 1000 \quad P_o = 9.81 \rho Q / 1000
 \end{aligned}$$

where  $P_o$  = power delivered by the pump (kW, hp)  
 $\rho$  = density of water (kg/m<sup>3</sup>, lb/ft<sup>3</sup>)  
 $g$  = acceleration of gravity (9.81 m/s<sup>2</sup>, 32.2 ft/s<sup>2</sup>)  
 $H$  = total head loss (m, ft)  
 $Q$  = flow rate (m<sup>3</sup>/s, ft<sup>3</sup>/s)

The power that must be supplied by the drive motor to the pump is  $P_s$ , where

$$P_s = P_o / \eta_p$$

The power input that must be supplied to the motor is  $P_i$ , where

$$P_i = P_s / \eta_m = P_o / \eta_p \eta_m$$

where  $P_s$  = power delivered to the pump (kW)  
 $\eta_p$  = pump efficiency  
 $P_i$  = input power to the pump motor (kW)  
 $\eta_m$  = efficiency of the motor

$P_o$  is sometimes called the *water power*.  $P_s$  is also known as the 'shaft' or 'brake' power.  $P_i$  is the power value used to estimate the pump power costs.



Discover the truth at [www.deloitte.ca/careers](http://www.deloitte.ca/careers)

**Deloitte.**

© Deloitte & Touche LLP and affiliated entities.



Click on the ad to read more

## 14.5 Calculating Head Losses from $K$ Values

The pressure loss through pipes and pipe fittings is a multiple of the quantity  $v^2/2g$ ,

where  $v$  = fluid velocity (m/s)

$g$  = gravitational constant = 9.81 m/s<sup>2</sup> or 32.2 ft/s<sup>2</sup>

This is a measure of the kinetic energy of the moving fluid and can be measured in meters (or feet) or in pressure units (kPa or lb/in<sup>2</sup>). It is called the *velocity head* when it is measured in meters (or feet).

The *head loss for straight pipe* is

$$h_L = K \frac{v^2}{2g} \quad \text{where} \quad K = f \frac{L}{D} \quad \text{and} \quad h_L = f \frac{L}{D} \frac{v^2}{2g}$$

where  $f$ , the pipe *friction factor*, depends on the velocity, fluid viscosity, pipe diameter and pipe roughness.

The *head loss for pipe fittings* (elbows, valves, etc.) is

$$h_L = K \frac{v^2}{2g}$$

A few values of  $K$  are:

Standard 45° elbow:  $K = 0.35$

Standard 90° elbow:  $K = 0.75$

Gate valve: Fully open:  $K = 0.17$     ¼ closed:  $K = 0.9$

½ closed:  $K = 4.5$     ¾ closed:  $K = 24$

The head loss can be written in terms of flow instead of velocity. The flow in a pipe is

$$Q = vA \quad \text{and} \quad v = Q/A$$

and 
$$h_L = K \frac{Q^2}{2gA^2}$$

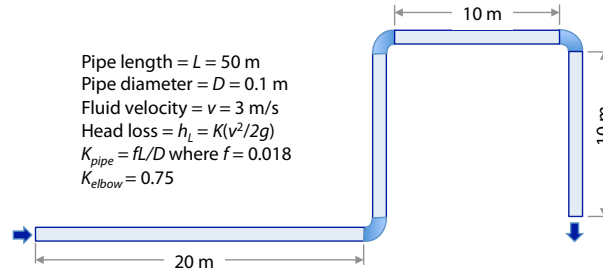
where  $A$  = cross-sectional area of the pipe (m<sup>2</sup>)

The system head curve can be developed as a quadratic equation

$$h = a + bQ + cQ^2$$

**Example 14.1 HEAD LOSS IN A PIPE WITH THREE ELBOWS**

Figure 14.5 a hypothetical pipe that is 50 m long and has three elbows. The friction loss is the same if this is a plan view (looking down) or an elevation view. The calculation is for the pipe alone, and does not include the static head due to change in elevation.



**Figure 14.5** Simple pipe section with  $L = 50$  m, 3 elbows, and  $v = 3$  m/s has a head loss of 5.16 m.

The quantity  $h_L = K \frac{v^2}{2g}$  will be used to calculate the head loss in every element of the piping system. For simplicity, in this piping system the diameter of pipe and the elbows is  $D = 0.1$  m. The velocity of water flowing in the system is  $v = 3$  m/s. The gravitational constant,  $g = 9.81$  m/s<sup>2</sup>. The headloss of any element can be calculated using

$$\frac{v^2}{2g} = \frac{(3 \text{ m/s})^2}{2(9.81 \text{ m/s}^2)} = 0.4587 \text{ m}$$

For the pipe friction factor use  $f = 0.018$ . The head loss due to pipe friction is

$$h_L = f \frac{Lv^2}{2gD} = 0.018 \left[ \frac{(50\text{m})(3 \text{ m/s})^2}{2(9.81 \text{ m/s}^2)(0.1\text{m})} \right] = 4.128 \text{ m}$$

The head losses for one elbow and 3 elbows are

$$h_{\text{elbow}} = K \frac{v^2}{2g} = 0.075 \left[ \frac{(3 \text{ m/s})^2}{2(9.81 \text{ m/s}^2)} \right] = 0.075(0.4587) = 0.344 \text{ m}$$

$$h_{3 \text{ elbows}} = 3 \left( K \frac{v^2}{2g} \right) = 3(0.075)(0.4587) = 1.032 \text{ m}$$

Now put a gate valve in the piping system (it does not matter where in the system). The fully open gate valve has  $K = 0.17$  and the head loss is

$$h_{\text{valve (100\% open)}} = 0.17(0.4587) = 0.078 \text{ m}$$

For a half-closed gate valve,  $K = 4.5$  and the head loss is

$$h_{\text{valve(50\% closed)}} = 4.5(0.4587) = 2.064 \text{ m}$$

For a 3/4-closed gate valve the head loss is

$$h_{\text{valve(75\% closed)}} = 24(0.4587) = 11.009 \text{ m}$$

The total friction head losses for some possible systems are:

- 50 m pipe + 3 elbows = 4.128 + 1.032 = 5.16 m
- 50 m pipe + 3 elbows + fully open gate valve = 4.128 + 1.032 + 0.078 m = 5.238 m
- 50 m pipe + 3 elbows + 50%-closed gate valve = 4.128 + 1.032 + 2.064 m = 7.221 m
- 50 m pipe + 3 elbows + 75%-closed gate valve = 4.128 + 1.032 + 11.009 m = 16.169 m

**Example 14.2 OPERATING HEAD FOR A PUMP**

The general expression for the energy balance of a hydraulic system is

$$\frac{p_1}{\gamma} + \frac{v_1^2}{2g} + z_1 + h_{pump} - h_{fittings} = \frac{p_2}{\gamma} + \frac{v_2^2}{2g} + z_2$$

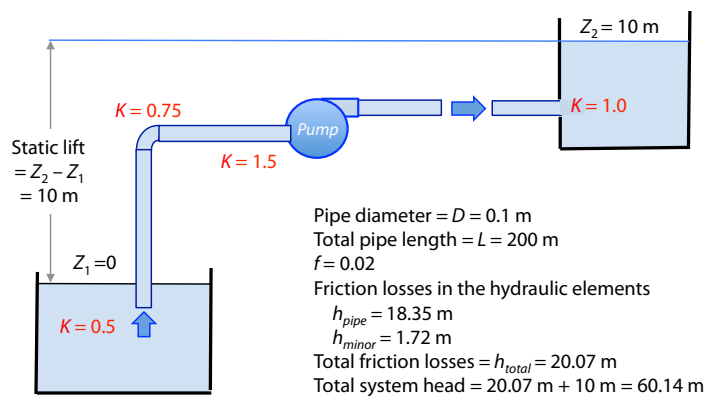
For the system in Figure 14.6, points 1 and 2 are at the surface of the two reservoirs. where  $z$  is elevation and  $p/\gamma$  is pressure expressed as meters. The diameter of the pipe is constant,  $D = 0.1$  m, so  $v_1 = v_2$ . The pressures at points 1 and 2 are atmospheric, so  $p_1 = p_2$ . Define the water surface elevation of the lower tank as  $z_1 = 0$  so  $z_2 = 10$  m. The head loss equation simplifies to  $h_{pump} = h_{fittings} + z_2$ .

As in the previous example, the pipe diameter is  $D = 0.1$  m and the velocity is 3 m/s, giving

$$\frac{v^2}{2g} = \frac{(3 \text{ m/s})^2}{2(9.81 \text{ m/s}^2)} = 0.4587 \text{ m}$$

The head loss in the pipe for a pipe friction factor of  $f = 0.02$  is

$$h_{pipe} = f \frac{L}{D} \frac{v^2}{2g} = 0.02 \left( \frac{200 \text{ m}}{0.1 \text{ m}} \right) 0.4587 \text{ m} = 18.35 \text{ m}$$



**Figure 14.6** The total system head of the pump is 30.07 m, which is a static lift of 10 m plus the friction loss in 200 m of 0.1 m diameter pipe, plus four minor losses (pipe inlet, pipe outlet, elbow, and pump intake).

There are four minor head losses:

- Inlet to the suction pipe  $K = 0.5$
- Outlet to the upper tank  $K = 1.0$
- Inlet to the pump  $K = 1.5$
- 90° elbow  $K = 0.75$

The total head loss for these four elements is

$$h_{minor} = (0.5 + 1.0 + 1.5 + 0.75)(0.4587 \text{ m}) = 3.75(0.4587 \text{ m}) = 1.72 \text{ m}$$

The pump must lift the fluid the 10 m of static head plus provide the energy to overcome the friction losses in the pipe and the minor losses in the fittings. The total head is

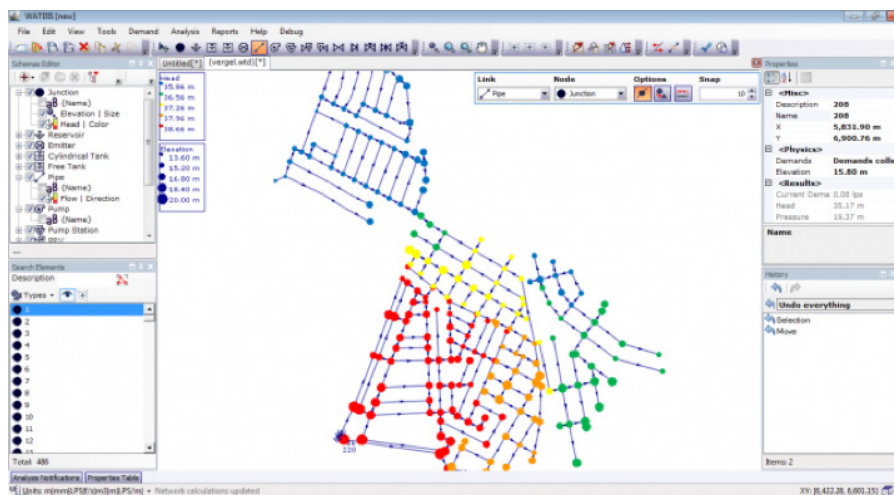
$$h = h_{static} + h_{pipe} + h_{minor} = 10 \text{ m} + 18.35 \text{ m} + 1.72 \text{ m} = 30.07 \text{ m}$$



### 14.6 Designing Pumping Systems to Minimize the Cost

Pumping accounts for about 20% of world energy usage so there are opportunities to find efficiencies. Changing pumps, pump impellers, motors, and pump controls can be cost effective. But it is often difficult and costly to make extensive piping changes in large existing system so the greatest opportunities are in systems yet to be built.

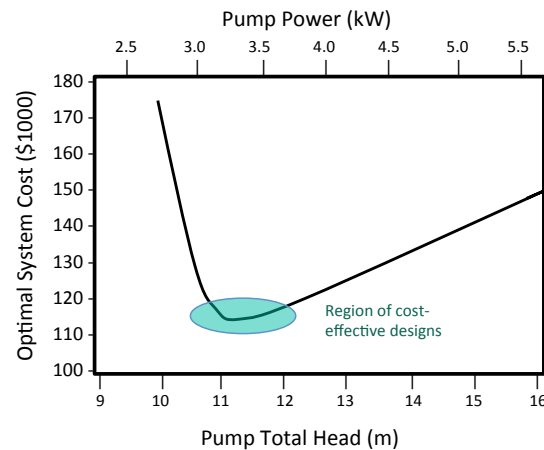
Figure 14.7 is an example of the complex pipe networks that are common. The nodes identify points of withdrawal. The input locations are not shown, but they could be pumping stations, elevated storage tanks, or reservoirs. This example comes from a web brochure about the WatDis software (Transparent Blue 2013)



**Figure 14.7** A complex looped hydraulic network being analyzed with the WatDis hydraulic network design software (Transparent Blue Consulting, 2013).

Such a network is analyzed using a system of equations that define the head loss in each pipe and a material balance equation for each loop, and an energy balance equation for each loop. The flow into each pipe junction must equal the flow out of the junction and there can only be one pressure at each junction. An initial assignment of flows is adjusted in an iterative solution (Epp & Fowler 1972).

Modern optimization technology can search simultaneously for a pipe and pump system that will minimize either the first cost or the life-cycle cost, Figure 14.8. An excellent source for pump and piping costs is Means (2014). Energy costs will be available locally.



**Figure 14.8** Optimized systems for pumps of different head levels and power show a region of cost effective designs. The design criterion was minimal life-cycle cost for a 20-year life.

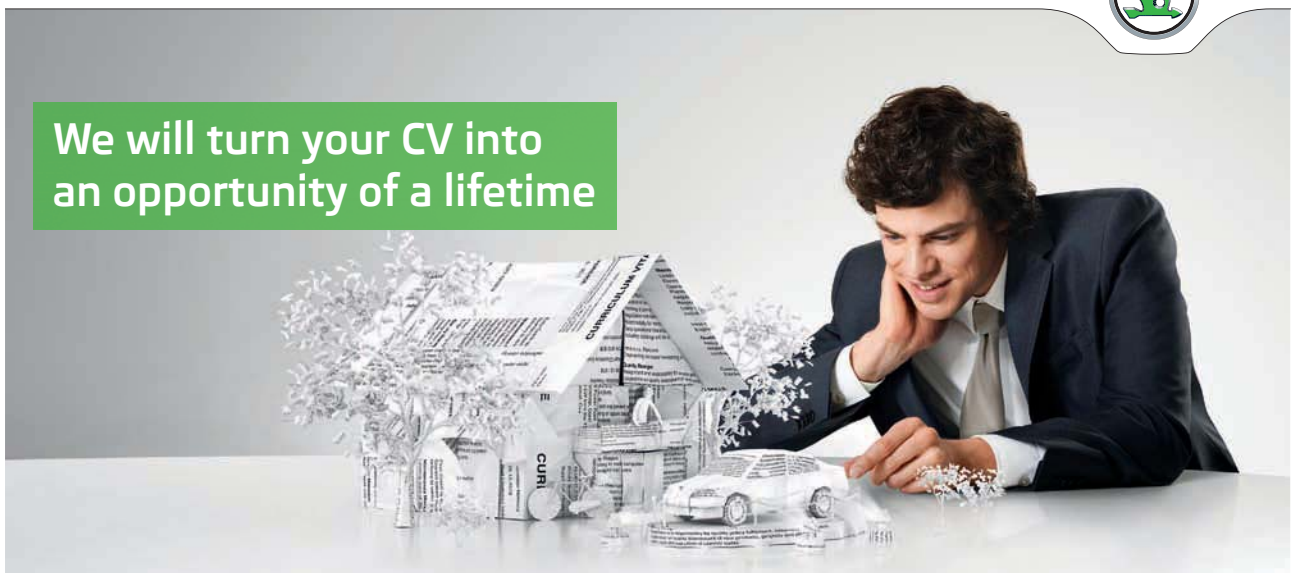
The traditional method of design was to specify the pipe system and select pumps that had the required discharge and operating head. Better design software has encouraged an iterative approach to simultaneously design the piping and the pumps by proposing a pipe system, selecting pumps, re-examining the pipe system, and so on (Hodgson & Walters, 2002). Some hydraulic design software packages are WatDis, EPANet, and WaterCAD.

SIMPLY CLEVER

ŠKODA



We will turn your CV into an opportunity of a lifetime



Do you like cars? Would you like to be a part of a successful brand? We will appreciate and reward both your enthusiasm and talent. Send us your CV. You will be surprised where it can take you.

Send us your CV on [www.employerforlife.com](http://www.employerforlife.com)



Click on the ad to read more

This concept is illustrated by finding the pipe diameter that minimizes the system cost for the pipe geometry shown in Figure 14.6, for a flow of 0.5 m<sup>3</sup>/s (11.4 mgd). The pump efficiency is  $\eta_p = 0.9$ , motor efficiency is  $\eta_m = 0.95$ , and the overall efficiency is  $\eta_p \eta_m = 0.855$ . The cost of power is \$0.08 per kWh. The cost of pipe, in 2013 US\$, with diameter  $D$  (m) is  $C_{pipe} = 620 D$ , and the cost of the pump is  $C_{pump} = 100,000D^{1.4}$ .

Pump output power (kW)  $P_o = \rho gHQ/1000 = (1000 \text{ kg/m}^3)(9.81 \text{ m/s}^2)(0.5 \text{ m}^3/\text{s}) H/1000$

Power input to pump motor (kW)  $P_t = P_o/\eta_p \eta_m$

The velocity head and the total friction loss are calculated for each pipe diameter as shown in Example 14.2. The results are in Table 14.1, along with the power requirements.

Pipe Diam. m	Pipe Area m <sup>2</sup>	Velocity m/s	Veloc-ity Head (v <sup>2</sup> /2g) M	Pipe Losses m	Minor Losses m	Static Loss m	Total Head Loss m	Output power kW	Annual Energy use kWh/y	Annual energy cost \$/y
0.4	0.1257	3.98	0.81	8.07	3.03	10	21.09	103.47	1,060,120	84,810
0.45	0.1590	3.14	0.50	4.48	1.89	10	16.37	80.28	822,509	65,801
0.5	0.1963	2.55	0.33	2.64	1.24	10	13.88	68.10	697,710	55,817
0.55	0.2376	2.10	0.23	1.64	0.85	10	12.49	61.26	627,596	50,208
0.6	0.2827	1.77	0.16	1.06	0.60	10	11.66	57.19	585,985	46,879
0.65	0.3318	1.51	0.12	0.71	0.43	10	11.15	54.67	560,143	44,811
0.7	0.3848	1.30	0.09	0.49	0.32	10	10.81	53.04	543,467	43,477
0.75	0.4418	1.13	0.07	0.35	0.24	10	10.59	51.96	532,349	42,588
0.8	0.5027	0.99	0.05	0.25	0.19	10	10.44	51.21	524,724	41,978
0.85	0.5674	0.88	0.04	0.19	0.15	10	10.33	50.69	519,363	41,549
0.9	0.6362	0.79	0.03	0.14	0.12	10	10.26	50.32	515,513	41,241
0.95	0.7088	0.71	0.03	0.11	0.10	10	10.20	50.04	512,693	41,015
1.0	0.7854	0.64	0.02	0.08	0.08	10	10.16	49.84	510,593	40,847

Notes: Flow = 0.5 m<sup>3</sup>/s, Pipe length = 200 m, Static head = 10 m  
Annual energy use is for pump efficiency = 90%, motor efficiency = 95% and continuous operation.

**Table 14.1** Hydraulic information, power output of the pump, and the annual energy requirement for continuous operation.

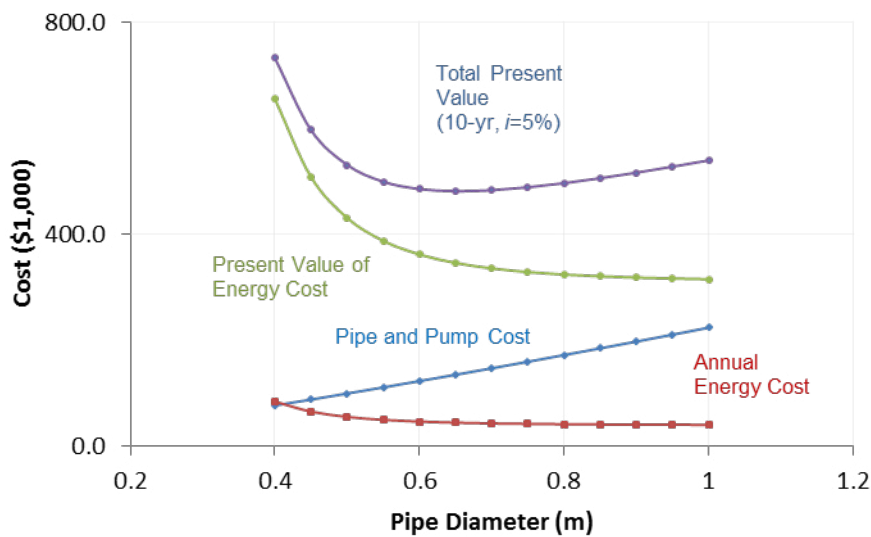
Obviously the cost of the pump and the piping increase as the diameter is increased. Also, the system head loss will decrease because of the lower friction losses in the larger pipes and the energy required will decrease. A criterion is needed that will combine the capital cost and the energy cost. Since the project will operate over some period of years that criterion should account for energy costs over the lifetime of the project.

The criterion that does this is the *Present Value*. The present value is the amount of money one would need in the bank at the beginning of the project (pre-construction) to buy the equipment and pay the energy cost for the project's lifetime. In this example, the project lifetime is 10 years and the cost of money is 5% per year.

The costs and the present value are shown in Figure 14.9. The minimum cost design is a 0.65 m pipe diameter, with a construction cost (pump & pipe only) of \$135,312, an annual energy cost of \$44,811, and a 10-year Present Value of \$481,334.

It is assumed that the cost of installing the pump and the piping is the same for all possible pipe diameters so this cost is omitted. Including it would simply shift the capital cost curve and the present value curves up by a small amount. It would not change the location of the minimum present value.

Table 14.2 gives the costs and the present value for 10 years of operation. The present value is the amount of money needed at the beginning of the project to buy the equipment and pay the energy cost for 10 years. Table 14.3 shows how that works out.



**Figure 14.9** The capital cost of the pump and piping, the annual energy cost, and the present value of the project for a 10-year life at 5% interest per year.

Pipe Diameter	Pipe unit cost	Total Pipe cost	Pump cost	Cost of Pipe + Pump	Annual energy Cost	Present Value of energy	Present Value for Total Cost
m	\$/m	\$	\$	\$	\$	\$	\$
0.40	248	49,600	27,726	77,326	84,810	654,877	732,203
0.45	279	55,800	32,696	88,496	65,801	508,096	596,592
0.50	310	62,000	37,893	99,893	55,817	431,003	530,895
0.55	341	68,200	43,302	111,502	50,208	387,690	499,192
0.60	372	74,400	48,912	123,312	46,879	361,986	485,297
0.65	403	80,600	54,712	135,312	44,811	346,022	481,334
0.70	434	86,800	60,693	147,493	43,477	335,721	483,214
0.75	465	93,000	66,848	159,848	42,588	328,853	488,700
0.80	496	99,200	73,169	172,369	41,978	324,142	496,511
0.85	527	105,400	79,650	185,050	41,549	320,831	505,881
0.90	558	111,600	86,286	197,886	41,241	318,452	516,338
0.95	589	117,800	93,071	210,871	41,015	316,710	527,581
1.00	620	124,000	100,000	224,000	40,847	315,413	539,413

Notes: Flow = 0.5 m<sup>3</sup>/s, Pipe length = 200 m, Static head = 10 m  
 Annual energy use is for pump efficiency = 90%, motor efficiency = 95% and continuous operation.  
 Electricity cost = \$0.08/kWh  
 Annual energy cost is based on continuous operation  
 Pay the energy bill at the end of the year  
 Present value is for 10 years at a 5% per year cost of money.

**Table 14.2** Capital cost of the pump and piping, annual energy cost, and the present value for energy and for the total cost over 10 years.

Year	Financial Activity	Interest Payment	or Balance
<b>Beginning of Year 1</b>			
0	Deposit equal to the Present Value		481,334
	Buy pump and Piping	-135,312	346,022
<b>End of Year 1</b>			
0	Interest on \$346,022 for 1 yr @ 5%	17,301	363,323
	Pay annual energy bill	-44,811	318,512
1	Interest on \$318,512 for 1 yr @ 5%	15,926	334,437
	Pay annual energy bill	-44,811	289,626
2	Interest on \$289,626 for 1 yr @ 5%	14,481	304,107
	Pay annual energy bill	-44,811	259,296
3	Interest on \$259,296 for 1 yr @ 5%	12,965	272,261
	Pay annual energy bill	-44,811	227,449
4	Interest on \$227,499 for 1 yr @ 5%	11,372	238,822
	Pay annual energy bill	-44,811	194,010
5	Interest on \$194,010 for 1 yr @ 5%	9,701	203,711
	Pay annual energy bill	-44,811	158,899
6	Interest on \$158,899 for 1 yr @ 5%	7,945	166,844
	Pay annual energy bill	-44,811	122,033
7	Interest on \$122,033 for 1 yr @ 5%	6,102	128,134
	Pay annual energy bill	-44,811	83,323
8	Interest on \$83,323 for 1 yr @ 5%	4,166	87,489
	Pay annual energy bill	-44,811	42,678
9	Interest on \$42,678 for 1 yr @ 5%	2,134	44,811
	Pay annual energy bill	-44,811	0

**Table 14.3** Project account with a balance of \$481,334 at the beginning of year 1 and a zero balance at the end of year 9 (10 years). The Present Value of the minimum cost project is \$481,334 (10 years @  $i = 5\%$ ), showing the present value is the amount of money that will pay for the project.

**Example 14.3** A SHORT NOTE ON THE PRESENT VALUE CALCULATION

The future value of an amount  $P_0$ , compounded for  $n$  years at interest rate  $i$  is

$$F_{n,i} = P_0(1+i)^n$$

For example,  $P_0 = \$10,000$  invested today for 10 years at 5% interest is worth

$$F_{10,5\%} = \$10,000(1+0.05)^{10} = \$10,000(1.6289) = \$16,289$$

The converse gives the present value

$$PV_{n,i} = \frac{F}{(1+i)^n}$$

The present value (PV) of a series of equal payments  $R$  over  $n$  time periods for an interest rate  $i$  is

$$PV_{n,i} = \sum_{j=1}^n \frac{R}{(1+i)^j} \quad PV_{n,i} = \sum_{j=1}^n \frac{R}{(1+i)^j} = \frac{R}{(1+i)^1} + \frac{R}{(1+i)^2} + \frac{R}{(1+i)^3} + \dots + \frac{R}{(1+i)^{n-1}} + \frac{R}{(1+i)^n}$$

The  $n$  terms are summed over the  $n$  year life of the project. The exponent  $j$  in the denominator is the year;  $j$  runs from 1 to  $n$ .

If the payments are not equal, that is  $R_j \neq R_{j+1}$ , calculate each term with the appropriate payment and sum the terms.

A payment of \$10,000 due in 10 years and valued at 5% per year is

$$PV_{n,i} = \frac{\$10,000}{(1+0.05)^{10}} = \$10,000 / 1.6289 = \$6,139$$

For example, the present values of \$10,000 payments to be made at 2, 4 and 6 years in the future is

$$PV = \frac{\$10,000}{(1+0.05)^2} + \frac{\$10,000}{(1+0.05)^4} + \frac{\$10,000}{(1+0.05)^6} = \frac{\$10,000}{1.1025} + \frac{\$10,000}{1.2155} + \frac{\$10,000}{1.3401} = \$24,759$$

A payment at time zero, say in the case where the present value is to pay for the purchase of some equipment and the stream of future operating costs, the initial payment is simply added to the sum. For example, if there is an initial cost of \$75,000 for equipment or a building, the PV with the three \$10,000 payments is

$$PV = \$75,000 + \frac{\$10,000}{(1+0.05)^2} + \frac{\$10,000}{(1+0.05)^4} + \frac{\$10,000}{(1+0.05)^6} = \$75,000 + \$24,759 = \$99,759$$

## 14.7 Air Blowers and Compressors

Industries use blowers and compressors on incinerators, sprayers, dryers, etc., and they use them to convey powders and for mixing and cleaning. Most air compressors run between 60-100 hours per week at or near full capacity. Up to 10% of electricity used in industry may be to run air compressors. It takes about 8 kW of energy to produce 1 kW worth of work with compressed air. One cubic foot per minute of air (1 cfm) costs about \$100 per year for energy.

Wastewater treatment plants use blowers to supply air to aerobic biological treatment process, in particular the activated sludge process. Insufficient air supply causes absolute failure to meet performance standards. This poses a design challenge because air requirements fluctuate continually due to changes in flow, organic load, temperature and atmospheric pressure.



The average amount of electricity used by modern treatment plants is  $0.3 \text{ kWh/m}^3$  of wastewater treated. (1,200 kWh per million gallons). Aeration accounts for 60–70% the overall energy demand. Pumping is about 12%.

A conventional activated sludge process will consume  $0.12\text{--}0.20 \text{ kWh/m}^3$  of wastewater treated (465–775 kWh per million gallons) (Henze 2008). If nitrification (oxidation of ammonia to nitrate) is added the air requirement increases by about 30%. A modern process that uses nitrification-denitrification with biological phosphorus removal needs less air, about  $0.10\text{--}0.15 \text{ kWh/m}^3$ .

Energy consumption will account for about 75% of the total life-cycle cost for an air blower, compared with 15% for capital cost and 10% for maintenance.

Multiple blowers can be installed to match the demand, or variable speed drives can be used. The installed blower capacity should be sufficient to meet the full load when one blower is out of service. The aeration system is usually designed to supply 200% of the average demand for air.

Instruments and closed loop controllers can be installed so the process is given only the air it needs at any time. Controlling the process dissolved oxygen concentration in the 1–2 mg/L range that is sufficient for a healthy process, instead of 4–5 mg/L, corresponds to a 35–70% reduction in air flow.

I joined MITAS because  
I wanted **real responsibility**

The Graduate Programme  
for Engineers and Geoscientists  
[www.discovermitas.com](http://www.discovermitas.com)



**Month 16**  
I was a construction supervisor in the North Sea advising and helping foremen solve problems

Real work  
International opportunities  
Three work placements



The basic concepts of air delivery systems are similar to liquid pumping systems, with the difference that air is compressible and liquids are not. Compression will raise the temperature of the air and as the temperature increases the power requirement goes up.

*Centrifugal blowers* are a popular means to supply air to an activated sludge process. The centrifugal blower, like a centrifugal pump, has an impeller on a rotating shaft. The output can be adjusted with a variable speed drive. The output will vary depending on the output pressure.

The blower has an operating curve that determines the relation of air flow and discharge pressure. The air delivery piping and equipment (filters, diffusers, etc.) determine the system power curve. This also relates air flow and discharge pressure. The intersection of the operating curve and the system curve is the operating point.

Figure 14.10 is the performance map for a variable speed centrifugal blower. The operating curves are shown for the maximum speed (100% rpm) and for a few other speeds. The lowest speed for a compressor is the *turndown limit*, or simply *turndown*. Turndown can also be given as a percentage of the rated flow. Values range from 45–60% but 50% is a good value for many blowers.

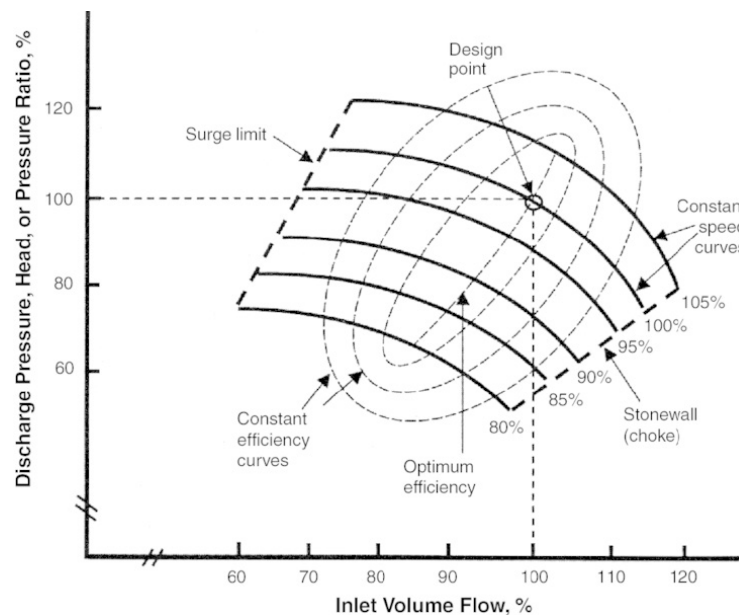


Figure 14.10 Centrifugal compressor performance map

*Surge* is the point at which the compressor cannot add enough energy to overcome the system resistance or backpressure. This causes a flow reversal, or surge.

*Choke* occurs as the airflow increases, its velocity can approach sonic speed somewhere within the compressor stage.

Figure 14.11 in Example 14.4 outlines the components that determine the operating pressure, which are

1. blower inlet filter and inlet manifold piping
2. header losses from blower to aeration tanks
3. drop-pipe and diffuser piping in basin
4. diffuser losses
5. static pressure water depth to diffuser
6. allowance for diffuser clogging
7. safety factor (usually 0.50–0.75 psia)

Items 1, 2, 5 and 7 are the responsibility of the process designer. Items 3, 4, and 6 are the responsibility of the diffuser equipment supplier (Environmental Dynamics Int'l 2005, 2011, Siemens AG/Turblex, Inc. 2009, Mueller et al 2002).

The static pressure due to the depth of the water over the diffuser is

$$p_s = k d$$

where  $k = 0.433$  for  $p_s =$  gage pressure (psig, lb/in<sup>2</sup>) and  $d =$  water depth (ft)

$k = 1.877$  for  $p_s =$  gage pressure (kg/cm<sup>2</sup>) and  $d =$  water depth (m)

$k = 0.01914$  for  $p_s =$  gage pressure (kP) and  $d =$  water depth (m)

Example 14.4 shows plausible pressure loss values for a simplified system.

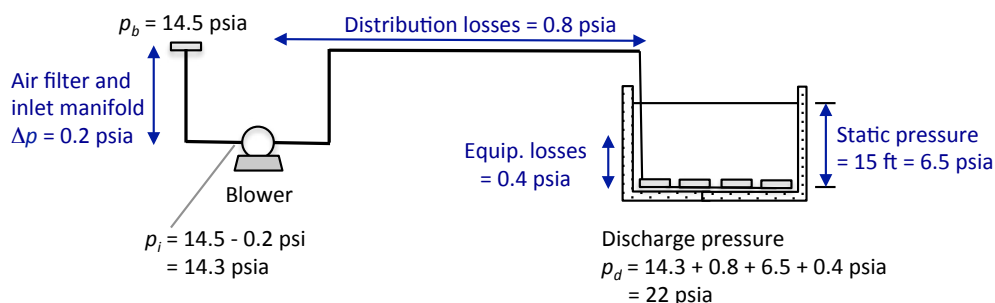
**Example 14.4 PRESSURE DROP IN FINE BUBBLE DIFFUSER SYSTEM**

The barometric pressure at the blower air filter inlet is 14.5 psia. The loss in the filter and the blower inlet manifold is 0.2 psi so the inlet pressure at the blower is  $14.5 - 0.2 = 14.3$  psia.

There is a pressure loss of 0.8 psi in the air distribution piping and a loss of 0.4 psi in the aeration tank downpipe and the fine bubble diffusers. The water depth of 15 ft causes a static pressure of 6.5 psi. This gives a diffuser discharge pressure of

$$P_{\text{discharge}} = 14.3 + 0.8 + 0.4 + 6.5 = 22 \text{ psia}$$

The design pressure is usually includes an allowance for a diffuser clogging (0.5 psi) and perhaps a safety factor (0.5 psia), which would give a design discharge pressure of 23 psia.



**Figure 14.11** Schematic of blower piping, aeration tank, and fine bubble diffusers, with pressure losses for the system components.

The power the blower imparts to the air is

$$P = m_{air} c_{p,air} \Delta T = \rho_{air} Q_{air} c_{p,air} \Delta T$$

where:  $m_{air}$  = mass flow rate of air at the inlet (kg/s, lb/w)

$Q_{air}$  = volume flow rate of air at the inlet ( m<sup>3</sup>/s, ft<sup>3</sup>/s)

$\rho_{air}$  = density of the inlet air (kg/m<sup>3</sup>, lb/ft<sup>3</sup>)

$c_{p, air}$  = specific heat of the air = 1.006 kJ/kg K (0.24 Btu/lb°R)

$T_1$  = inlet temperature (K, °R)

$T_2$  = outlet temperature (K, °R)

$\Delta T = T_2 - T_1$  = temperature increase across the blower (K, °R)

$c_{p, air} \Delta T$  = change in enthalpy across the blower, (kJ/kg, Btu/lb)

The outlet temperature is a function of the inlet temperature and the inlet and outlet pressures,  $p_1$  and  $p_2$ , respectively

$$T_2 = T_1 \left( \frac{p_2}{p_1} \right)^{0.286}$$

$$\Delta T = T_2 - T_1 = T_1 \left[ \left( \frac{p_2}{p_1} \right)^{0.286} - 1 \right]$$

**ie business school**

#1 EUROPEAN BUSINESS SCHOOL  
FINANCIAL TIMES 2013

**#gobeyond**

**MASTER IN MANAGEMENT**

**Because achieving your dreams is your greatest challenge.** IE Business School's Master in Management taught in English, Spanish or bilingually, trains young high performance professionals at the beginning of their career through an innovative and stimulating program that will help them reach their full potential.

- Choose your area of specialization.
- Customize your master through the different options offered.
- Global Immersion Weeks in locations such as London, Silicon Valley or Shanghai.

*Because you change, we change with you.*

www.ie.edu/master-management | mim.admissions@ie.edu | f t in YouTube

Finally

$$P = m_{air} c_{p,air} T_1 \left[ \left( \frac{p_2}{p_1} \right)^{0.286} - 1 \right] = \rho_{air} Q_{air} c_{p,air} T_1 \left[ \left( \frac{p_2}{p_1} \right)^{0.286} - 1 \right]$$

These are absolute temperatures:  $K = 273 + ^\circ C$ ,  $^{\circ}R = 460 + ^\circ F$ . The pressures are absolute pressures (i.e. gauge pressure plus atmospheric pressure). (Note: In some references the exponent on the pressure ratio is 0.283.)

**Example 14.5 BLOWER OUTLET TEMPERATURE**

A blower operates at atmospheric (barometric) pressure  $p_b = 14.6$  psia with a pressure drop  $\Delta p = 0.2$  psig through the inlet filter and inlet manifold. This makes the blower inlet pressure  $p_1 = 14.6 - 0.2 = 14.4$  psia. The inlet temperature  $T_1 = 50^\circ F = 510^\circ R$ . The outlet pressure is 8.0 psig, which gives  $p_2 = 14.4 + 8.0 = 22.4$  psia.

The outlet temperature  $T_2$  is

$$T_2 = T_1 \left( \frac{p_2}{p_1} \right)^{0.286} = (510 \text{ } ^\circ R) \left( \frac{22.4 \text{ psia}}{14.4 \text{ psia}} \right)^{0.286} = 578.7 \text{ } ^\circ R = 118.7 \text{ } ^\circ F$$

$$\Delta T = T_2 - T_1 = 118.7^\circ F - 50^\circ F = 68.7^\circ F$$

**Example 14.6 BLOWER POWER**

The air requirement is 14,000 scfm and the air density is 0.075 lb/ft<sup>3</sup>. The inlet conditions are  $p_1 = 14.2$  psia and  $T_1 = 55^\circ F = 515^\circ R$ . The outlet pressure is 14.2 psig + 8.5 psig = 22.7 psia. The specific heat for air is 0.24 Btu/lb<sup>o</sup>F (0.24 Btu/lb<sup>o</sup>R).

Calculate the blower power.

$$\begin{aligned} P &= \rho_{air} Q_{air} c_{p,air} T_1 \left[ \left( \frac{p_2}{p_1} \right)^{0.286} - 1 \right] \\ &= \left( 14,000 \frac{\text{ft}^3}{\text{m}} \right) \left( 0.075 \frac{\text{lb}}{\text{ft}^3} \right) \left( 0.24 \frac{\text{Btu}}{\text{lb}^\circ R} \right) (515^\circ R) \left[ \left( \frac{22.7 \text{ psia}}{14.2 \text{ psia}} \right)^{0.286} - 1 \right] \\ &= 18,640 \text{ Btu/m} = 1,118,000 \text{ Btu/hr} \end{aligned}$$

$$P = (1,118,000 \text{ Btu/h}) (1 \text{ hp}/2,544 \text{ Btu/h}) = 439.5 \text{ hp}$$

$$P = (1,118,000 \text{ Btu/h}) (2.931 \times 10^{-4} \text{ kW/Btu/h}) = 327.7 \text{ kW}$$

$$P = (1,118,000 \text{ Btu/h}) (1 \text{ kJ}/0.9478 \text{ Btu}) = 1,180,000 \text{ kJ/h} = 1,180 \text{ MJ/h}$$

**Example 14.7** DIURNAL AIR FLOW VARIATION

The organic load on an activated sludge process changes continually, typically being a minimum in the early morning, with a peak mid-day and evening. The load is at 100% of the daily average from 0800–1000 hours and the average daily air flow rate for this time interval is 14,000 scfm. The blower inlet pressure is 14.2 psia. The demand for air is given in columns 1–4 of Table 14.4. The discharge pressure in column 6 is based on a blower inlet pressure of 14.2 psia. The calculation of columns 7–9 is explained in the footnotes to the table. The inlet temperature  $T_1 = 55\text{ }^\circ\text{F} = 515\text{ }^\circ\text{R}$ .

Hour of day	% of time	% of average daily flow	Inlet airflow rate, $Q$ (scfm)	Discharge pressure (psig)	Discharge pressure (psia) <sup>(a)</sup>	Adiabatic Factor $X_a$ <sup>(b)</sup>	Power $P$ (hp) <sup>(c)</sup>	Prorated Power (hp) <sup>(d)</sup>
0000-0500	20.8	70	9,800	8.2	22.4	0.1392	298.3	62.2
0500-0800	12.5	90	12,800	8.4	22.6	0.1421	397.8	49.7
0800-1000	8.3	100	14,000	8.5	22.7	0.1436	439.5	36.6
1000-1800	33.3	110	15,400	8.6	22.8	0.1450	488.3	162.8
1800-2400	25	120	16,800	8.9	23.1	0.1493	548.4	137.1
Totals	100							448.4

(a) psia = 14.2 +  $p_g$

(b)  $X_a$  = adiabatic factor =  $[(p_2/p_1)^{0.286} - 1]$

(c) Power (Btu/min) =  $Q_{air} r_{air} c_{p,air} T_1 [(p_2/p_1)^{0.286} - 1] = Q (0.075\text{ lb/ft}^3)(0.24\text{ Btu/lb}^\circ\text{R})(515^\circ\text{R})X_a$   
Power (hp) = Power (Btu/min)(60 m/h)/2,544 Btu/hp = 0.2186  $Q X_a$

(d) Prorated Power (hp) = [% of time][Power (hp)]

**Table 14.4** Blower operation for a typical day with flow rates, discharge pressures, and power requirements.

The inlet air flow rate in cubic feet per minute (ICFM) is

$$Q_{ICFM} = Q_{scfm} \left( \frac{P_{Std}}{P_{in}} \right) \left( \frac{T_{in}}{T_{Std}} \right)$$

$$Q_{ICFM} = Q_{acfm} \left( \frac{P_{Ref}}{P_{in}} \right) \left( \frac{T_{in}}{T_{Ref}} \right)$$

where  $p$  = absolute pressure (psia, kPa)

$T_{in}$  = absolute temperature of inlet air (K, °R)

$m$  = mass flow rate (lb/m, kg/m)

The subscripts *Std* and *Ref* indicate standard and reference conditions, respectively.

Similar conversions can be made between actual cubic meter and Normal cubic meter. A useful conversion for flow rates is 1 scfm = 0.622 Nm<sup>3</sup>/h



The mass and volume of air required is easily obtained in most applications, such as ventilation air or incineration air supply. An important application that is not obvious is for the supply of oxygen to an activated sludge wastewater treatment process. The details, which are not within the scope of this book, may be found in any textbook about biological wastewater treatment design (Qasim 1998, Henze 2008). Still, this discussion of air blowers seems incomplete without a rough outline of the procedure.

**Example 14.8 ESTIMATING THE REQUIRED AIR FLOW**

A 1mgd activated sludge process needs an oxygen supply of 3,150 lb/d.

The oxygen content of 1 scfm of air is 0.0173 lb O<sub>2</sub>/min = 24.91 lb O<sub>2</sub>/d.

The selected fine bubble diffusers will dissolve 29% of this oxygen operating in clean water at 20°C, 1 atm, and 0 mg/L dissolved oxygen (DO) concentration.

The standard oxygen transfer rate (*SOTR*) is

$$SOTR = 0.29(24.91 \text{ lb O}_2/\text{d}) = 7.224 \text{ lb O}_2/\text{d per scfm of air supplied}$$

The oxygen transfer rate wastewater at field conditions is less than the *SOTR* for a variety of reasons, such as the temperature not being 20°C, different air pressure, impurities in the wastewater, and the DO concentration being 1-2 mg/L (instead of zero). Making adjustments for such factors gives an *actual oxygen transfer rate (AOTR)* of

$$AOTR = 0.33 \text{ SOTR}$$

$$AOTR = 0.33(7.224 \text{ lb O}_2/\text{d}) = 2.384 \text{ lb O}_2/\text{d per scfm air supplied}$$

The required air flow rate is

$$Q_{air} = \frac{\text{O}_2 \text{ demand}}{AOTR} = \frac{3,150 \text{ lb O}_2/\text{d}}{\left(2.384 \frac{\text{lb O}_2/\text{d}}{\text{scfm}}\right)} = 1,321 \text{ scfm}$$

## 14.8 Conclusion

This simplified introduction of how the design of piping systems and the selection of pumps relates to energy consumption is not sufficient to do actual hydraulic design, but it should alert you to opportunities to economize.

The pipe-pump system is rarely a single long pipe with a pump at one end. Actual systems have branches and loops, changes in pipe diameter, many kinds of restrictions in the network (valves, heat exchangers, etc.) and changes in elevation.

Air supply for an activated sludge process will account for 60% or more of the total energy use in conventional wastewater treatment. The design of air blowers is in many ways similar to the design of liquid pumps. The main difference is that air is compressible and this comes into the calculation of the power requirements.



# 15 References

Anon. 1887, 'The Boston Sewer System and Main Drainage Works,' *Scientific American*, no. 28, p 351.

Allen, DT & Rosselot, KS 1996, *Pollution Prevention for Chemical Processes*, Wiley-Interscience, N Al-Shemerri, T 2010, *Wind Turbines*, Ventus Publishing, bookboon.com.

Anderson, RB 2007, 'Don't Blow This One Off', *Clean Tech.ASHRAE, Handbook – Fundamentals, Chapter 1*, American Soc. of Heating, Refrigerating and Air-Conditioning Engineers, Atlanta, GA.

Aspen Technology 2013, Aspen Plus Technology Brochure, Burlington, MA.

Balik, JA & Koraido, SM 1991, 'Identifying Pollution Prevention Options for a Petroleum Refinery', *Pollution Prevention Review*, vol. 1, pp 273–293.

Berthouex, PM & Brown, LC 2013, *Pollution Prevention and Control: Human Health and Environmental Quality*, Bookboon.com, London.

Berthouex, PM & Rudd, DF 1977, *The Strategy of Pollution Control*, John Wiley.

**no.1**  
nine years  
in a row

Sweden  
Stockholm

## STUDY AT A TOP RANKED INTERNATIONAL BUSINESS SCHOOL

Reach your full potential at the Stockholm School of Economics, in one of the most innovative cities in the world. The School is ranked by the Financial Times as the number one business school in the Nordic and Baltic countries.

Visit us at [www.hhs.se](http://www.hhs.se)

STOCKHOLM SCHOOL  
OF ECONOMICS

Betz 1991, *Betz Handbook of Industrial Water Conditioning*, 9th Ed, Betz Laboratories.

Caban, R & Chapman, TW 1972, 'Losses of mercury from chlorine plants: A review of a pollution problem.' *Amer. Inst. Chem. Engr. Jour*, vol. 18, pp 892–903.

Chadha, N & Parmele, CS 1997, 'Minimize Emissions of Air Toxics via Process Changes', pp 24–29, *The Environment: Air, Water; and Soil*, Gail F. Nalven, Editor, Amer. Inst. of Chemical Engr., New York.

Chang, TY et al. 1991, 'Alternative Transportation Fuels and Air Quality', *Environ. Sci. Technol.*, vol. 25, pp 1190–1198.

Chapman, PF. et al. 1974, 'The Energy Cost of Fuels', *Energy Policy*, Sept 1974.

Christensen, JH 1970, 'The Structuring of Process Optimization,' *AIChE Jour.*, vol. 16, p 177.

Christensen, JH & Rudd, DF 1968, 'Structuring design computations,' *AIChE Jour.*, vol. 15, pp 94–100.

Clarke, EC 1888, *Main Drainage Works of the City of Boston*. Boston: Rockwell & Churchill.

Cunningham, VL 1994, 'Cost Analysis as A Pollution Control Tool', *Waste Management*, vol. 14, pp 309–315.

Daeil Aqua Co., Ltd, *Cooling Tower Thermal Design Manual* (available as download).

Degremont 1991, *Water Treatment Handbook*, Vol. 1 & 2.

Dhole VR, et al. 1996, 'Make your process water pay for itself,' *Chemical Engineering*. vol. 103, pp 100–103.

Earth Tech 2004, *Walworth Country Metropolitan Sewerage District (WalCoMEt) WWTF Digester Gas Utilization Study*, Walworth County Metropolitan Sewerage District, Delevan, WI.

Eaton, G & Lutras, J, 2008, 'Turning Methane into Money: Cost-Effective Methane Co-Generation Using Microturbines at a Small Waste Water Plant', in *Ensuring a Sustainable Future: An Energy Management Guidebook for Wastewater and Water Facilities*, US EPA, EPA 832-RA-08-002, 113 p.

El-Halwagi MM & Manousiouthakis V 1989, 'Synthesis of mass exchange networks,' *AIChE Journal*, vol. 35 pp 1233–1244.

El-Halwagi MM 1997, *Pollution Prevention through Process Integration: Systematic Design Tools*. San Diego, CA: Academic Press.

Environmental Dynamics International 2011, Aeration Pipe Sizes, *Technical Bulletin 136*, Columbia, MO.

Environmental Dynamics International 2005, Blower, *Technical Bulletin 145*, Columbia, MO.

Epp, R & Fowler, A 1970, 'Efficient code for steady-state flows in networks', *Journal of the Hydraulics Division, Proc. ASCE*, vol. 96 (HY1), pp 43–56.

Flynn, D 1992, *The Nalco Guide to Cooling-Water Systems Failure Analysis*, McGraw-Hill, New York.

Flynn, D 2009, *The Nalco Water Handbook*, 3<sup>rd</sup> ed. McGraw-Hill, New York

Foo, DCY, Manan, ZA & Tan, YL 2006, 'Use Cascade Analysis to Optimize Water Networks', *Environmental Management*, vol. 7, pp 45–52.

Fox, RD 1973, 'Control Pollution at the Source', *Chem. Engr.*, vol. 8, pp 72–82.

Fthenakis, VM 1993, *Prevention and Control of Accidental Releases of Hazardous Gases*, Van Nostrand Reinhold, New York.

Green, DW et al 1984. *Perry's Chemical Engineers Handbook*, 6th ed, McGraw-Hill, New York.

Grundfos 2013, *The Sewage Pumping Handbook*, download from [www.grundfos.com](http://www.grundfos.com)

Henze, M (ed.) 2008, *Biological Wastewater Treatment: Principles, Modelling and Design*, IWA Publishing.

Hertz, DW 1990, 'Minimization of Arsenic Wastes in the Semiconductor Industry', pp.131–42, In: Freeman, HM 1990, *Physical/Chemical Processes*. Lancaster, Technomic, p.131–42.

Himmelblau, DM & Bischoff, KB 1968, *Process Analysis and Simulation*, Wiley, New York.

Himmelblau, DM & Riggs, JB 12004, *Basic Principles and Calculations in Chemical Engineering*, 7<sup>th</sup> ed., Prentice Hall.

Hodgson, J & Walters T 2002, 'Optimizing Pumping Systems to Minimize First or Life-Cycle Costs', (presented at the 19th International Pump Users Symposium), *Pumps & Systems Magazine*, Oct. 2002.

Holman, EC 1971, *Optimum Networks for Heat Exchange*, PhD Thesis, Univ. Southern California, Los Angeles, CA

Hydromantis 2014, Hydromantis Environmental Systems Software, [www.hydomantis.com](http://www.hydomantis.com), Hamilton, Ontario, Canada

Klemes, J, Lam, HL & Foo, DCY 2009, *Water Recycling and Recovery*, presented at Total Food 2009.

Knopf, FC 2008, The Heat Exchanger Network (THEN), Louisiana State University ([www.mpri.isu.edu](http://www.mpri.isu.edu))

Komilis, D, Konstantinos, K & Symeonidis, A 2013, 'Effect of organic matter and moisture on the calorific value of solid wastes: A update of the Tanner diagram,' *Waste Management*, vol. 34, pp 249–255.

Koppol APR, et al. 2003, 'On zero discharge solutions in the process industry,' *Adv. Env. Res*, vol. 8, pp 151–171.

Krofcheck, D & Stone, JN 1975, *Science and Engineering for Pollution-Free Systems*, Ann Arbor Science Inc., Ann Arbor, Michigan.

Lee, W & Rudd, DF 1966, 'On the ordering of recycle calculations,' *AIChE Jour.*, vol. 12, pp 1184–1190.

#1  
in eco-friendly  
attitude

**STUDY AT  
LINKÖPING UNIVERSITY, SWEDEN**  
RANKED AMONG TOP 50 UNIVERSITIES UNDER 50

Interested in Strategy and Management in International Organisations? Kick-start your career with a master's degree from Linköping University, Sweden.

→ **Click here!**

 **Linköping University**

- Lee, W, Christensen, & Rudd, DF 1966, 'Design variable selection to simplify process calculations,' *AIChE Jour.*, vol. 12, 1104–1115.
- Lewis, AE 2010, 'Review of metal sulphide precipitation,' *Hydrometallurgy*, vol. 104, – 222–234.
- Linnhoff, B & Hindmarsh, E 1983, 'The Pinch Design Method for Heat Exchanger Networks,' *Chemical Engineering Science*, vol. 38, pp, 745–763.
- Linnhoff B, et al. 1982, *A User Guide on Process Integration for the Efficient Use of Energy*. Rugby, UK: The Institution of Chemical Engineers.
- Mackie, JA & Niesen, K 1984, 'Hazardous Waste Management: The Alternatives,' *Chem. Engr.*, vol. 8, pp 51–64.
- Malle, KG 1994, 'Efforts of BASF Towards Cleaner Technology and Waste Minimisation,' in *Waste Minimisation: A Chemist's Approach*, ed. by K. Martin and TW Bastock, Royal Chemical Society, London.
- Manan, ZA, Foo DCY, Tan YL 2004, 'Targeting the minimum water flow rate using water cascade analysis technique,' *AIChE Journal* vol. 50, pp 3169–83.
- Manan ZA, et al. 2003, 'Heat-MATRIX—A computer software for the reduction of energy and water in process plants.' *31st Int. Exhibition of Invention, New Techniques and Products*. Geneva, Switzerland.
- Mann, JG & Liu YA 1999, *Industrial Water Reuse and Wastewater Minimisation*. New York, NY: McGraw-Hill; 1999.
- Martin, A & Mato, FA 2008, 'HINT: An educational software for heat exchanger network design with the pinch method,' *Education for Chemical Engineers*, vol. 3, pp e6–e14.
- McBean, AE, Rovers, FA & Farquhar, GJ 1995, *Solid Waste Landfill Engineering and Design*, Chap. 7 and Appendix C, Prentice Hall, New Jersey.
- Means, RS 2014, *RSMeans Building Construction Cost Data 2014*, 72<sup>nd</sup> ed., RS Means.
- Means, RS 2014, *RSMeans Mechanical Cost Data 2014*, 37<sup>th</sup> ed., RS Means.
- Mueller, JA, Boyle, WC & Popel, HJ 2002, *Aeration: Principles and Practice*, CRC Press, Boca Raton. FL.

Murphy, RM 2007, *Introduction to Chemical Processes: Principles, Analysis and Synthesis*, McGraw-Hill, Boston.

Overcash, MR 1987, *Techniques for Industrial Pollution Prevention*, Lewis Publishers, Ann Arbor, MI.

Owen, WF 1982, *Energy in Wastewater Treatment*, Prentice-Hall, Englewood Cliffs, NJ.

Pacala, S & Socolow, R 2004, 'Stabilization Wedges: Solving the Climate Problem for the Next 50 Years with Current Technologies', *Science*. 968–972.

Patt, JJ & Banholzer, WF 2009, Improving Energy Efficiency in the Chemical Industry, *The Bridge, National Academy of Engineering*, vol. 39, pp 15–22.

Polley GT & Polley HL 2000, 'Design better water networks', *Chemical Engineering Progress*. vol. 96 pp 47–52.

Petrides, D, Koulouris, A & Claudranis, J 2001, 'Process Modeling Evaluates Feasibility of Water Recycling', *Filtration+Separation*, vol. 10, pp. 26–31.

Petrides, D, Siletti, C & Claudranis, J 2002, 'The Role of Process Simulation in Evaluating Water Recycling Opportunities at a Semiconductor Fabrication Facility', *Ultrapure Water*, vol. 4, pp26–34.

Petrides, D 2014, "Bioprocess Design and Economics", in *Bioseparations Science and Engineering by Harrison, R et al. Oxford University Press*,

[Puchajda B & Oleszkiewicz J](#) 2008, 'Impact of sludge thickening on energy recovery from anaerobic digestion', *Water Sci Technol.*, vol. 57, pp 395–401

Qasim, SR 1998, *Wastewater Treatment Plants: Planning, Design and Operation*, CRC Press, Boca Rotan, FL.

Reinhart, DR 2004, 'Determining the Chemical Composition of Solid Waste', <http://msw.cecs.ucf.edu/Exercise-Chemcomposition.pdf>

Robinson, OH 1968, 'Industrial Waste Discharge Application – Mock Hearing', *Jour. Water Pollution Control Fed*, vol. 5, pp 805–834.

Rossman L 2000, *EPANET Users Manual*. Environmental Protection Agency, Risk Reduction Engineering Laboratory, Cincinnati.



Rossner, AP 1995, *Waste Minimization Through Process Design*, McGraw-Hill, New York.

Rudd, DF & Watson CC 1968, *The Strategy of Process Engineering*, John Wiley, New York.

Rudd, DF et al. 1973, *Process Synthesis*, Prentice Hall, Englewood Cliffs, NJ.

Reusser, S. and G. Zelinka (2004). 'Laboratory-Scale Comparison of Anaerobic-Digestion Alternatives.' *Water Environment Research*, 76(4): 360–379.

Sama, DA 1995, 'The Use of the Second Law of Thermodynamics in Process Design,' *J. Energy Resources Tech*, 117, 179–186.

Seader, JD, Henley, EJ & Roper, DK 2010, *Separation Process Principles*, Wiley, NY.

Seider, WD, et al. 2008, *Product and Process Design Principles: Synthesis, Analysis and Design*, Wiley, NY.

Socolow, R. & Pacala, S. 2006, 'A Plan to Keep Carbon In Check,' *Scientific American*, pp 1–7.

Somaida, M, Elzahar, M & Sharan M 2011, 'A Suggestion of Optimization Process For Water Pipe Network Design', International Conf. on Environment and Bioscience, Singapore.



"I studied English for 16 years but...  
...I finally learned to speak it in just six lessons"  
Jane, Chinese architect

ENGLISH OUT THERE

Click to hear me talking before and after my unique course download



- Snurer, H 2008, 'Sludge Production from chemical precipitation', Lund Tekniska Hogskola, Lund, Sweden
- Steelman, BL & Spencer, JD 1996, 'Breaking Away from End-of-Pipe Treatment', *Industrial Wastewater*, vol. 4, pp 29–32.
- Straltz, JF 1993, 'Capture Heat from Air-Pollution Control', *Chem. Engr.*, vol. 10, pp 614.
- Takama N, et al. 1980, 'Optimal water allocation in a petroleum refinery', *Computers and Chemical Engineering*, vol. 4, pp 251–258.
- Tchobanoglous, G., F. Burton, et al. 2003. 'Wastewater Engineering Treatment, Disposal and Reuse', Tata McGraw-Hill.
- Tetra Tech 2012, Bioenergy Optimization Assessment at Wastewater Treatment Plants, Final Report, Oregon Department of Energy.
- Transparent Blue 2014, WatDis Software, [www.WatDis.com](http://www.WatDis.com)
- Turblex, Inc., A Siemens AG company 2009, 'Optimizing the aeration system – White Paper', Siemens AG, Springfield, MO
- U.S. EPA 1988, Waste Minimization Opportunities Assessment Manual, 625/7–88/003, Cincinnati.
- U.S. EPA 1989, Design Manual: Fine Pore Diffuser Systems, Office of Research and Development, EPA/625/1-89/023, Cincinnati.
- U.S. EPA 1993, Guides to Pollution Prevention: Municipal Pretreatment Programs, EPA/625/R-93/006, Oct. 1993.
- U.S. EPA 2001, *Guide to Industrial Assessments for Pollution Prevention and Energy Efficiency*, EPA Office of Research and Development, 2001, EPA/625/R-99-003
- U.S. EPA 2006, *Greenhouse Gas Emissions from the U.S. Transportation Sector, 1990–2003*, US EPA Office of Transportation & Air Quality, 2006, EPA-420-F-11-041
- U.S. EPA 2008, *Ensuring a Sustainable Future: An Energy Management Guidebook for Wastewater and Water Facilities*, EPA 832-RA-08-002, 113 p.
- U.S. EPA 2009, Landfill Gas Energy Project Development Handbook, Washington, DC.

U.S. EPA 2010, *Evaluation of Energy Conservation Measures*, EPA 832-R-10-005, Washington, DC.

U.S. EPA 2011, *Greenhouse Gas Emissions from a Typical Passenger Vehicle*, US EPA Office of Transportation & Air Quality, 2011, EPA-420-F-11-041

Vatavuk, VA et al 2002, *VOC Controls, Chap 2 in The EPA Air Pollution Control Cost Manual*, EPA/452/B-02-001, U.S. Environmental Protection Agency, Washington, DC.

Vik, TE 2003. *Anaerobic Digester Methane to Energy: A Statewide Assessment*, Wisconsin Focus on Energy.

Wang YP & Smith R 1994, 'Wastewater minimisation,' *Chem. Engr. Sci.*, vol. 49, pp 981–1006.

Warfvinge, P 2009, *Process Calculations and Reactor Calculations for Environmental Engineering*, Lund Institute of Technology, Lund, Sweden.

Wayman, M & Parekh, SR 1990. *Biotechnology of Biomass Conversion*, Prentice Hall, Englewood Cliffs, NJ.

WEF 2009, Energy Conservation in Water and Wastewater Facilities, *Water Environment Federation Manual of Practice No. 32*, McGraw-Hill, NY.

Worrell, WA, Reinhart, DR & Vesilind, PA 2007, *Solid Waste Engineering*, Cengage Engineering.

Excellent Economics and Business programmes at:



university of  
 groningen



“The perfect start  
of a successful,  
international career.”

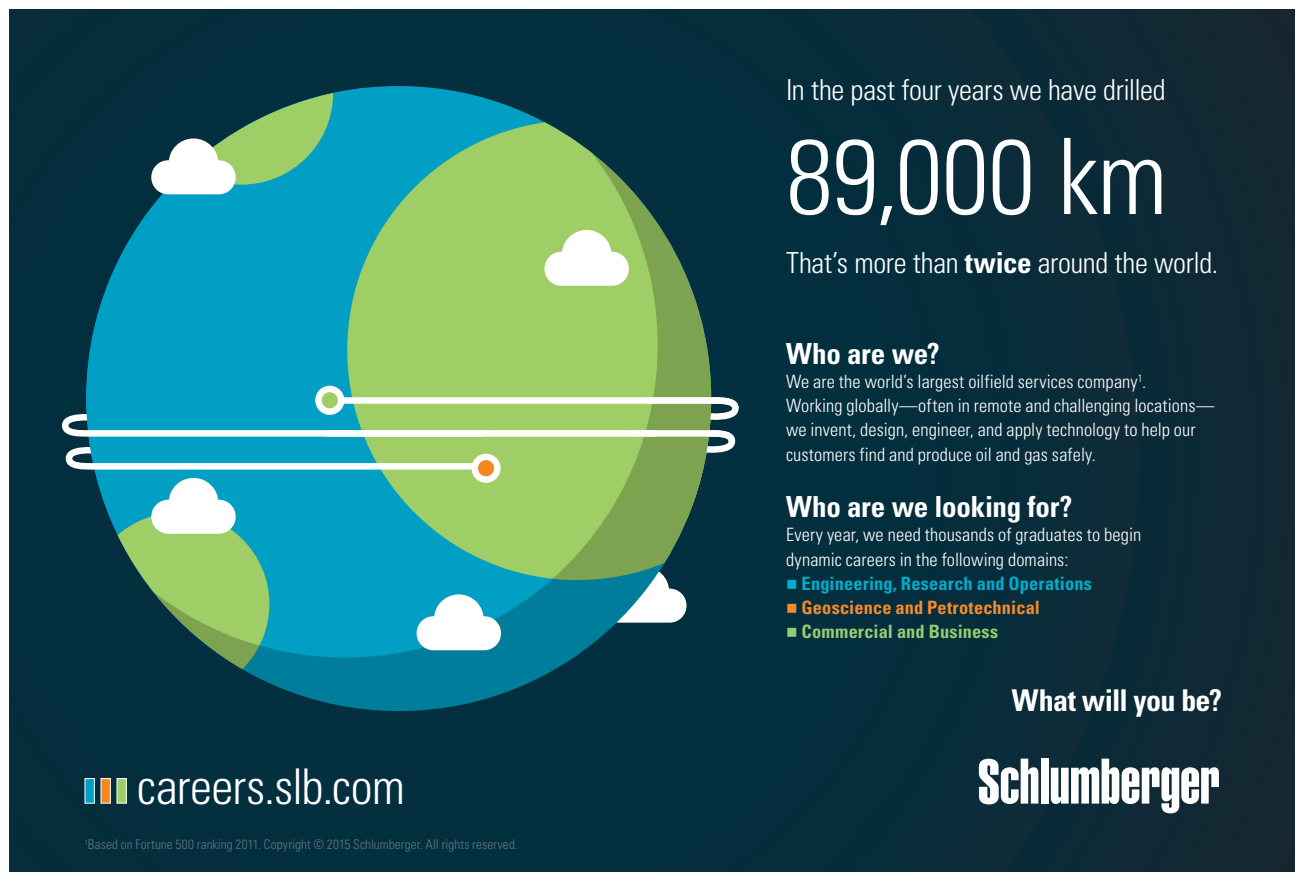
**CLICK HERE**  
to discover why both socially  
and academically the University  
of Groningen is one of the best  
places for a student to be

[www.rug.nl/feb/education](http://www.rug.nl/feb/education)

# 16 Appendix 1 – Atomic Numbers and Atomic Masses

Actinium	Ac	89	227.0278	Helium	He	2	4.0026
Aluminum	Al	13	26.98154	Holmium	Ho	67	164.9304
Americium	Am	95	(243)	Hydrogen	H	1	1.0079
Antimony	Sb	51	121.75	Indium	In	49	114.82
Argon	Ar	18	39.948	Iodine	I	53	126.9045
Arsenic	As	33	74.9216	Iridium	Ir	77	192.22
Astatine	At	85	(210)	Iron	Fe	26	55.847
Barium	Ba	56	137.33	Krypton	Kr	36	83.80
Berkelium	Bk	97	(247)	Lanthanum	La	57	138.9055
Beryllium	Be	4	9.01218	Lawrencium	Lr	103	(260)
Bismuth	Bi	83	208.9804	Lead	Pb	82	207.2
Boron	B	5	10.81	Lithium	Li	3	6.941
Bromine	Br	35	79.904	Magnesium	Mg	12	24.305
Cadmium	Cd	48	112.41	Manganese	Mn	25	54.9380
Calcium	Ca	20	40.08	Mendelevium	Md	101	(258)
Californium	Cf	98	(251)	Mercury	Hg	80	200.59
Carbon	C	6	12.011	Molybdenum	Mo	42	95.94
Cerium	Ce	58	140.12	Neodymium	Nd	60	144.24
Cesium	Cs	55	132.9054	Neon	Ne	10	20.179
Chlorine	Cl	17	35.453	Neptunium	Np	93	237.0482
Chromium	Cr	24	51.966	Nickel	Ni	28	58.70
Cobalt	Co	27	58.9332	Niobium	Nb	41	92.9064
Copper	Cu	29	63.546	Nitrogen	N	7	14.0067
Curium	Cm	96	(247)	Nobelium	No	102	(259)
Dysprosium	Dy	66	162.50	Osmium	Os	76	190.2
Einsteinium	Es	99	(254)	Oxygen	O	8	15.9994
Erbium	Er	68	167.26	Palladium	Pd	46	106.4
Europium	Eu	63	151.96	Phosphorus	P	15	30.97376
Fermium	Fm	100	(257)	Platinum	Pt	78	195.09
Fluorine	F	9	18.99840	Polonium	Pu	94	(244)
Francium	Fr	87	(223)	Potassium	K	19	39.0983
Gadolinium	Gd	64	157.25	Praseodymium	Pr	59	140.9077
Gallium	Ga	31	69.72	Promethium	Pm	61	(145)
Germanium	Ge	32	72.59	Protactinium	Pa	91	231.0389
Gold	Au	79	196.9665	Radium	Ra	88	226.0254
Hafnium	Hf	72	178.49	Radon	Rn	86	(222)

Rhenium	Re	75	186.207	Terbium	Tb	65	158.9254
Rhodium	Rh	45	102.9055	Thallium	Tl	81	204.37
Rubidium	Ru	44	101.07	Thorium	Th	90	232.0381
Ruthenium	Ru	44	101.07	Thulium	Tm	69	168.9342
Samarium	Sm	62	150.4	Tin	Sn	50	118.69
Scandium	Sc	21	44.9559	Titanium	Ti	22	47.90
Selenium	Se	34	78.96	Tungsten	W	74	183.85
Silicon	Si	14	28.0855	Uranium	U	92	238.029
Silver	Ag	47	107.868	Vanadium	V	23	50.9414
Sodium	Na	11	22.98977	Xenon	Xo	54	131.30
Strontium	Sr	38	87.62	Ytterbium	Yb	70	173.04
Sulfur	S	16	32.06	Yttrium	Y	39	88.9059
Tantalum	Ta	73	180.9479	Zinc	Zn	30	65.38
Technetium	Tc	43	(97)	Zirconium	Zr	40	91.22
Tellurium	Te	52	127.60				



In the past four years we have drilled

# 89,000 km

That's more than **twice** around the world.

**Who are we?**  
We are the world's largest oilfield services company<sup>1</sup>. Working globally—often in remote and challenging locations—we invent, design, engineer, and apply technology to help our customers find and produce oil and gas safely.

**Who are we looking for?**  
Every year, we need thousands of graduates to begin dynamic careers in the following domains:

- Engineering, Research and Operations
- Geoscience and Petrotechnical
- Commercial and Business

**What will you be?**

[careers.slb.com](https://careers.slb.com)

**Schlumberger**

<sup>1</sup>Based on Fortune 500 ranking 2011. Copyright © 2015 Schlumberger. All rights reserved.



# 17 Appendix 2 – Conversion Factors

## Linear Measure Equivalents

meter	foot	centimeter	inch
1	3.2808	100	39.37
0.2048	1	30.48	12.0
100	0.03281	1	0.3937
0.0254	0.0833	2.54	1

## Area Equivalents

hectare	sq. meter	acre	sq. feet
1	10,000	2.471	107,639.1
0.001	1	0.000247	10.764
0.4047	4,046.9	1	43,560
9.29x10 <sup>-6</sup>	0.0929	0.000,023	1

## Volume Equivalents (U.S. units)

cubic foot	U. S. gallon	acre-foot	barrel (U.S. petroleum)
1	7.48	---	0.1781
0.1337	1	0.000,0031	
43,560	325,851	1	
65.615	42.0	---	1

## Volume Equivalents (Metric & U.S.)

liter	cubic meter	U.S. gallon	cubic foot
1	0.001	0.2642	0.0353
1000	1	264.172	35.315
3.785	0.00378	1	0.1337
28.317	0.02832	7.48	1

## Power Equivalents

horsepower	kilowatt	ft-lb/sec	Btu/sec
1	0.7457	550	0.7068
1.341	1	737.56	0.9478
0.001,818	0.001,356	1	0.001285
1.415	1.055	778.16	1

Heat, Energy, or Work Equivalents

Joule = kg-m	ft-lb	kWh	hp-h	Liter-atm	Btu
1	7.233	$2.724 \times 10^{-6}$	$3.653 \times 10^{-6}$	0.0968	0.009,296
0.1383	1	$3,766 \times 10^{-7}$	$5.050 \times 10^{-7}$	0.0134	0.000,324
367,100	2,655,000	1	1.341	35,534	3412.8
273,750	1,980,000	0.7455	1	26,494	2,545
10.33	74.73	$2.815 \times 10^{-5}$	$3.774 \times 10^{-5}$	1	0.0242
426.7	3,086	0.001,162	0.001,558	41.29	1
107.6	778.16	0.000,293	0.000,393	10.41	0.252
0.4267	3.086	$1.162 \times 10^{-6}$	$1.558 \times 10^{-6}$	0.0413	0.001



**American online**  
**LIGS University**  
is currently enrolling in the  
Interactive Online **BBA, MBA, MSc,**  
**DBA and PhD** programs:

- ▶ enroll **by September 30th, 2014** and
- ▶ **save up to 16%** on the tuition!
- ▶ pay in 10 installments / 2 years
- ▶ Interactive **Online** education
- ▶ visit [www.ligsuniversity.com](http://www.ligsuniversity.com) to find out more!

**Note: LIGS University is not accredited by any nationally recognized accrediting agency listed by the US Secretary of Education. More info [here](#).**



# 18 Appendix 3 – Densities and Specific Weights

U. S. Units			SI Units		
Temperature (°F)	Density $\rho$ (lb/ft <sup>3</sup> )	Specific Weight $\gamma$ (lb/ft <sup>3</sup> )	Temperature (°C)	Density $\rho$ (kg/m <sup>3</sup> )	Specific Weight $\gamma$ (N/m <sup>3</sup> )
-40	0.0946358	9.456	-40	1.514	14.85
-20	0.0903210	9.026	-20	1.395	13.68
0	0.0863926	8.633	0	1.293	12.67
10	0.0845572	8.449	5	1.269	12.45
20	0.0827862	8.273	10	1.247	12.23
30	0.0811118	8.104	15	1.225	12.01
40	0.0795018	7.942	20	1.204	481
50	0.0779240	7.786	25	1.184	11.61
60	0.0764106	7.636	30	1.165	11.43
70	0.0749938	7.492	40	1.127	11.05
80	0.0736092	7.353	50	1.109	10.88
90	0.0722568	7.219	60	1.060	10.40
100	0.0709688	7.090	70	1.029	10.09
120	0.0685216	6.846	80	0.9996	9.803
140	0.0662354	6.617	90	0.9721	9.533
160	0.0640780	6.404	100	0.9461	9.278
180	0.0620816	6.204	200	0.7461	7.317
200	0.0602140	6.016	300	0.6159	6.040
300	0.0522928	5.224	400	0.5243	5.142
400	0.0462070	4.616	500	0.4565	4.477
500	0.0413770	4.135	1000	0.2772	2.719
750	0.0328440	3.280			
1,000	0.0272090	2.717			
1,500	0.0202538	2.024			

The correct unit for density is slugs/ft<sup>3</sup>; the more convenient and unit is lb/ft<sup>3</sup>  
Specific weight = (density)(acceleration of gravity)

**Table A3.1** Density and specific weight of air (at 1 atm)



Gas	Formula	Molar Mass	Density $\rho$ lb/ft <sup>3</sup>	Density $\rho$ kg/m <sup>3</sup>
Air	---	29	0.0808	1.2943
Ammonia	NH <sub>3</sub>	17.03	0.0482	0.7721
Carbon dioxide	CO <sub>2</sub>	44	0.1235	1.9783
Chlorine	Cl <sub>2</sub>	70.91	0.2011	3.2213
Hydrogen	H <sub>2</sub>	2.016	0.0056	0.0897
Methane	CH <sub>4</sub>	16.03	0.0448	0.7176
Nitrogen	N <sub>2</sub>	28.022	0.0782	1.2527
Oxygen	O <sub>2</sub>	32	0.0892	1.4289
Sulfur dioxide	SO <sub>2</sub>	64.06	0.1825	2.9234

**Table A3.2** Densities of selected gases at 1 atm and 0°C

.....Alcatel-Lucent 

[www.alcatel-lucent.com/careers](http://www.alcatel-lucent.com/careers)



What if you could build your future and create the future?

One generation's transformation is the next's status quo. In the near future, people may soon think it's strange that devices ever had to be "plugged in." To obtain that status, there needs to be "The Shift".



Click on the ad to read more

Gas	Formula	Molar Mass (g/g-mol)	Density	
			(kg/m <sup>3</sup> )	(lb/ft <sup>3</sup> )
Acetylene	C <sub>2</sub> H <sub>2</sub>	26.02	1.1708	0.0732
Air			1.2928	0.0808
Ammonia	NH <sub>3</sub>	17.03	0.7708	0.0482
Butane	C <sub>4</sub> H <sub>10</sub>	58.08	2.5985	0.1623
Carbon dioxide	CO <sub>2</sub>	44.00	1.9768	0.1235
Carbon monoxide	CO	28.00	1.2501	0.0781
Chlorine	Cl <sub>2</sub>	70.91	3.2204	0.2011
Cyanogen	C <sub>2</sub> N <sub>2</sub>	52.02	2.3348	0.1459
Ethane	C <sub>2</sub> H <sub>6</sub>	30.05	2.8700	0.1793
Ethylene	C <sub>2</sub> H <sub>4</sub>	28.03	1.2644	0.0783
Fluorine	F <sub>2</sub>	38.00	1.6354	0.1022
Hydrogen	H <sub>2</sub>	2.016	0.0898	0.0056
Hydrogen chloride	HCl	36.47	1.6394	0.1024
Hydrogen sulfide	H <sub>2</sub> S	34.08	1.5992	0.0961
Methane	CH <sub>4</sub>	16.03	0.7167	0.0448
Methyl chloride	CH <sub>3</sub> Cl	50.48	2.3044	0.1440
Natural gas		19.5	0.7-0.9	0.044–0.056
Nitrogen	N <sub>2</sub>	28.02	1.2507	0.0782
Oxygen	O <sub>2</sub>	32.00	1.4289	0.0892
Propane	C <sub>3</sub> H <sub>8</sub>	44.09	1.882	0.1175
Sulfur dioxide	SO <sub>2</sub>	64.06	2.9268	0.1828
Water vapor (steam)	H <sub>2</sub> O	18.016	0.804	0.048

**Table A3.3** Density of gases at standard conditions (0°C and 1 atm)

Mass Percent (%)	Aluminum Sulfate $\text{Al}_2(\text{SO}_4)_3$ (15°C)	Ammonium Nitrate $\text{NH}_4\text{NO}_3$ (25°C)	Calcium Chloride $\text{CaCl}_2$ (20°C)	Chromic Acid $\text{CrO}_3$ (15°C)	Ferric chloride $\text{FeCl}_3$ (20°C)	Ferrous Sulfate $\text{FeSO}_4$ (18°C)	Hydrogen Chloride $\text{HCl}$ (20°C)	Sodium Carbonate $\text{NaCO}_3$ (20°C)	Sodium Chloride $\text{NaCl}$ (20°C)	Sulfuric acid $\text{H}_2\text{SO}_4$ (20°C)
1 %	1.0093	1.0011	1.0148	1.006	1.0086	1.0085	1.0032	1.0086	1.0095	1.0051
2 %	1.0195	1.0051	1.0316	1.014	1.0152		1.0082	1.0190	1.0207	1.0104
4 %	1.0404	1.0132	1.0659		1.0324	1.0375	1.0181	1.0398	1.0428	1.0250
6 %				1.045			1.0279	1.0816		1.0385
8 %	1.0837	1.0297	1.1015		1.0669	1.0785	1.0376	1.1244	1.0869	1.0522
10 %				1.076			1.0474			1.0661
12 %	1.1293	1.0464	1.1386		1.104	1.122	1.0574	1.1244	1.1309	1.0802
16 %	1.1770	1.0633	1.1775	1.127	1.000	1.1675	1.0878		1.1751	1.1094
20 %	1.2272	1.0806	1.2284	1.163	1.182	1.2135	1.0980		1.2191	1.1394
24 %	1.2803	1.0982					1.1187		1.2629	1.1704
26 %	1.3079			1.220			1.1290			1.1862
28 %		1.1161					1.1392		1.3064	1.2023
30 %		1.1252	1.2816	1.260	1.000		1.1493			1.2185
35 %			1.3373		1.353					1.2599
40 %		1.1727	1.3957	1.371	1.4175		1.1980		1.4300	1.3028
50 %		1.2229		1.505	1.551				1.5253	1.3951

**Table A3.4** Density (kg/m<sup>3</sup>) of aqueous inorganic solutions

Concentration (mass %)	Acetic Acid	Methyl Alcohol	Ethyl Alcohol	Glycerol
0	0.9982	0.9982	0.9982	0.9982
1	0.9996	0.9965	0.99636	1.0006
2	1.0012	0.9948	0.99453	1.003
3	1.0025	0.9931	0.99275	1.0054
4	1.004	0.9914	0.99103	1.0078
5	1.0055	0.9896	0.98938	1.01015
10	1.0141	0.9815	0.98043	1.0221
15	1.0213	0.974	0.97514	1.0345
20	1.0283	0.9666	0.97864	1.0469
25	1.0349	0.9592	0.96168	1.0598
30	1.0411	0.9515	0.95362	1.0727
40	1.0488	0.9345	0.93518	1.0993
50	1.0575	0.9156	0.91384	1.1263
60	1.0642	0.8946	0.89113	1.1538
70	1.0685	0.8715	0.86766	1.18125
80	1.07	0.8469	0.84344	1.2085
90	1.0661	0.8202	0.81797	1.2351
100	1.0498	0.7917	0.78934	1.2611

**Table A3.5** Density (kg/m<sup>3</sup>) of aqueous organic solutions at 20°C

Material	Sp. gr.	Ave. Density (lb/ft <sup>3</sup> )	Material	Sp. gr.	Ave. Density (lb/ft <sup>3</sup> )
<b>Metals</b>			<b>Various liquids</b>		
Aluminum	2.55–2.8	165	Alcohol, ethyl (100%)	0.79	49
Bronze	7.4–8.9	554	Alcohol, methyl (100%)	0.80	50
Iron, gray cast	7.03–7.10	442	Acid, nitric (91%)	1.50	94
hematite ore	5.2	325	Acid, sulfuric (87%)	1.80	112
magnetite ore	4.9–5.2	315	Chloroform	1.50	95
Lead	11.34	710	Oils, vegetable	0.91–0.94	58
galena ore	7.3–7.6	465	<b>Concrete masonry</b>		
Steel, cold-drawn	7.83	489	cement, stone, sand	2.2–2.4	144
<b>Various solids</b>			slag, etc.	1.9–2.3	130
Cereals, corn (bulk)	0.73	45	cinder, etc.	1.5–1.7	100
Cotton, flax, hemp	1.47–1.50	93	<b>Earth, etc., excavated</b>		
Glass, common	2.4–2.8	162	Clay, dry	1.00	63
Glass, plate	2.45–2.72	161	damp plastic	1.76	110
Glass, flint	3.2–4.7	247	Earth, dry loose	1.20	76
Leather	0.86–1.02	59	dry, packed	1.5	95
Paper	0.70–1.15	58	moist, loose	1.30	78
Rubber, goods	1.0–2.0	94	moist, packed	1.60	96
Salt, granulated (piled)	0.77	48	<b>Bituminous substances</b>		
Sulfur	1.93–2.07	125	Asphalt	1.11–1.5	81
<b>Timber</b>			Refined (kerosene)	0.78–0.82	54
Fir, Douglas	0.48–0.55	32	Gasoline	0.70–0.75	45
Maple, white	0.53	33	Tar, bituminous	1.2	75
Oak, white	0.77	4	<b>Coal and coke, piled</b>		
Redwood, California	0.42	26	anthracite	0.75–0.93	47–58
Teak, African	0.99	62	bituminous	0.64–0.87	40–54
<b>Stone, quarried &amp; piled</b>			charcoal	0.166–0.23	10–14
Limestone, marble, quartz	1.50	95	coke	0.37–0.51	23–34
Sandstone	1.30	82			

**Table A3.6** Approximate specific gravities and densities of miscellaneous solids and liquids.

# 19 Appendix 4 – Heating Values

The heating value is the amount of heat produced by combustion of a unit quantity of a fuel. We differentiate between gross and net heating values:

**Gross (or high, upper) Heating Value.** The gross or high heating value is the amount of heat produced by the complete combustion of a unit quantity of fuel. The gross heating value is obtained when all products of the combustion are cooled down to the temperature before the water vapor formed during combustion is condensed.

**Net (or lower) Heating Value.** The net or lower heating value is obtained by subtracting the latent heat of vaporization of the water vapor formed by the combustion from the gross or higher heating value.

Common Units for heating values:

$$1 \text{ Btu/ft}^3 = 8.9 \text{ kcal/m}^3 = 3.73 \times 10^4 \text{ J/m}^3$$

$$1 \text{ Btu/lb} = 2,326.1 \text{ J/kg} = 0.55556 \text{ kcal/kg}$$

$$1 \text{ J/kg} = 0.00043 \text{ Btu/lb} = 2.39 \times 10^{-4} \text{ kcal/kg}$$

$$1 \text{ kcal/kg} = 1.80 \text{ Btu/lb} = 4,187 \text{ J/kg}$$

Gas	Gross Heating Value		Net Heating Value	
	(Btu/ft <sup>3</sup> )	(Btu/lb)	(Btu/ft <sup>3</sup> )	(Btu/lb)
Acetylene (ethyne) – C <sub>2</sub> H <sub>2</sub>	1,498	21,569	1,447	20,837
Blast Furnace gas	92	1,178	92	1,178
Butane – C <sub>4</sub> H <sub>10</sub>	3,225	21,640	2,977	19,976
Butylene (Butene)	3,077	20,780	2,876	19,420
Carbon monoxide – CO	323	4,368	323	4,368
Coke Oven Gas	574	17,048	514	15,266
Digester Gas (Sewage or Biogas)	690	11,316	621	10,184
Ethane – C <sub>2</sub> H <sub>6</sub>	1,783	22,198	1,630	20,295
Hydrogen (H <sub>2</sub> )	325	61,084	275	51,628
Landfill Gas	476			
Methane – CH <sub>4</sub>	1,011	23,811	910	21,433
Natural Gas (typical)	950–1,150	19,500–22,500	850–1,050	17,500–22,000
Propane – C <sub>3</sub> H <sub>8</sub>	2,572	21,500	2,365	19,770
Propene (Propylene) – C <sub>3</sub> H <sub>6</sub>	2,332	20,990	2,181	19,630
Sasol	500	14,550	443	13,016
Water Gas (bituminous)	261	4,881	239	4,469

**Table A4.1** Gross and Net Heating Value of Some Gases

Chemical Substance	Btu/lb	kJ/kg	Chemical	Btu/lb	kJ/kg
<b>Gases</b>			<b>Liquids</b>		
Ammonia (anhydrous)	8,000	18,608	Acetaldehyde	11,390	26,493
Cyanogen	8,930	20,771	Acetic acid	6,265	14,572
Formaldehyde	8,180	19,027	Acetone	13,260	30,843
Isobutane	19,610	45,613	Benzene	17,260	40,147
Methane	21,500	50,009	Butyl alcohol	15,530	36,123
Methyl chloride	5,850	13,607	Chlorobenzene	12,000	27,912
Propylene	19,700	45,822	Creosote (coal tar)	12,500	29,075
Vinyl chloride	8,140	18,934	Cresol	14,700	34,192
<b>Solids</b>			Diesel fuel	18,400	42,798
Anthracene	17,300	40,240	Ethyl acetate	11,000	25,586
Benzoic acid	11,370	26,447	Ethylbenzene	17,600	40,938
Citric acid (anhydrous)	4,390	10,211	Ethylene glycol	8,175	19,015
Hexachlorobenzene	3,220	7,490	Ethylene glycol diacetate	15,000	34,890
Menthol	17,380	40,426	Glycerine (glycerol)	7,760	18,050
Naphthalene	17,300	40,240	Heptane	19,380	45,078
Nitrobenzene	7,400	17,212	Hexane	19,230	44,729
Nitrophenol	8,900	20,701	Kerosene	15,500	36,053
p-Nitrotoluene	11,665	27,133	Methyl acetate	9,260	21,539
Palmitic acid	16,470	38,309	Methyl alcohol	9,755	22,690
Phenanthrene	17,020	39,589	Methyl ethyl ketone	14,600	33,960
Phenol	14,000	32,564	Methyl mercaptan	11,050	25,702
Phthalic acid	8,350	19,422	Motor oil	18,500	43,031
Polypropylene	19,600	45,590	Naphtha	18,000	41,868
Stearic acid	17,060	39,682	Nicotine	11,510	26,772
Strychnine	14,460	33,634	Nitrobenzene	10,810	25,144
Sucrose	7,090	16,491	o-Nitrotoluene	11,290	26,261
Tannic acid	9,810	22,818	Octanol	17,440	40,565
Trichloroacetic acid	1,020	2,373	Oil, crude	18,250	42,450
Trinitrobenzene	5,600	13,026	Oil, vegetable	16,000	37,216
Trinitrotoluene	6,500	15,119	Pentane	19,340	44,985
Urethane	8,025	18,666	Polypropylene glycol	14,200	33,029
Wax (Paraffin)	18,000	41,868	Propyl alcohol	14,460	33,634
			Styrene	18,100	42,101
			Tallow	18,000	41,868
			Tetraethyl lead	7,870	18,306
			Toluene	17,420	40,519
			Triethylaluminum	18,360	42,705
			Vinyl acetate	9,750	22,679
			Xylene	17,500	40,705

**Table A4.2** Heat of combustion of selected chemical compounds.

# 20 Appendix 5 – Enthalpy of Water and Steam

T (°F)	Vapor Pressure Atm	Enthalpy, Btu/lb		
		Sat. Liquid	$\Delta H_v$	Sat. Vapor
32	0.0060	0	1075.1	1075.1
40	0.0083	8.05	1070.5	1078.6
50	0.0121	18.07	1064.8	1082.9
60	0.0174	28.07	1059.1	1087.2
70	0.0247	38.05	1053.4	1091.5
80	0.0345	48.02	1047.8	1095.8
90	0.0475	58.00	1042.1	1100.1
100	0.0646	67.97	1036.4	1104.4
110	0.0867	77.94	1030.9	1108.8
120	0.115	87.91	1025.3	1113.2
130	0.151	97.89	1019.5	1117.4
140	0.196	107.88	1013.7	1121.6
150	0.253	117.87	1007.8	1125.7
160	0.332	127.87	1002.0	1129.9
170	0.408	137.89	996.1	1134.0
180	0.511	147.91	990.2	1138.1
190	0.635	157.95	984.1	1142.1
200	0.784	167.99	977.8	1145.8
210	0.961	178.06	971.5	1149.6
212	1.000	180.07	970.3	1150.4
220	1.170	188.14	965.2	1153.3
230	1.414	198.22	958.7	1156.9
240	1.699	208.34	952.1	1160.4
250	2.029	218.48	945.3	1163.8
260	2.411	228.65	938.6	1167.3
270	2.848	238.84	931.8	1170.6
280	3.348	249.06	924.6	1173.7
290	3.916	259.31	917.4	1176.7
300	4.560	269.60	910.1	1179.7

T (°C)	Vapor Pressure kPa	Enthalpy, kJ/kg		
		Sat. Liquid	$\Delta H_v$	Sat. Vapor
0	0.62	0	2500.9	2500.9
5	0.87	21.02	2489.1	2510.1
10	1.23	42.02	2477.2	2519.2
15	1.71	62.98	2465.4	2528.4
20	2.34	83.92	2453.6	2537.5
25	3.17	104.84	2441.7	2546.5
30	4.25	125.75	2429.9	2555.6
35	5.63	146.64	2418.0	2564.6
40	7.38	167.54	2406.0	2573.5
45	9.59	188.44	2394.1	2582.5
50	12.35	209.34	2382.0	2591.3
55	15.67	230.24	2369.9	2600.1
60	19.95	251.15	2357.7	2608.8
65	25.04	272.08	2346.4	2618.5
70	31.20	293.02	2333.1	2626.1
75	38.60	313.97	2320.6	2634.6
80	47.41	334.95	2308.1	2643.0
85	57.87	355.95	2295.4	2651.3
90	70.18	376.97	2282.5	2659.5
95	84.61	398.02	2269.6	2667.6
100	101.33	419.10	2256.5	2675.6
110	143.38	461.36	2229.7	2691.1
120	198.67	503.78	2202.1	2705.9
130	270.26	546.39	2173.7	2720.1
140	361.50	589.20	2144.2	2733.4
150	476.10	632.25	2113.7	2745.9
160	618.14	675.57	2081.8	2757.4
170	792.05	719.21	2048.7	2767.9
180	1002.60	763.19	2014.0	2777.2

**Table A5.1** Enthalpy and latent heat of vaporization,  $\Delta H_v$ , of saturated water and steam.

(Complete steam tables can be found in Perry's Chemical Engineer's Handbook, 8<sup>th</sup> ed. (2006), CRC Press, Boca Rotan.



# Index

3-stage countercurrent rinse, 80

## A

absolute pressure, 278

absolute zero, 182

AC motors, 258

accuracy, 69

acetic acid, 230

activated sludge, 125, 153, 158, 272, 279

aerated lagoon, 134

Aeration, 273

Aeration tank, 153

*aerobic*, 122

aerobic bacteria, 153

aerobic biological treatment, 272

air delivery piping, 274

air flow rate, 278

air requirement, 244

air supply, 272

American Society of Mechanical Engineers, 206

*anaerobic*, 123

anaerobic fermentation, 228

Anaerobic Sludge Digestion, 123, 234

*analysis*, 14

*approach*, 202

arithmetic equivalence, 184

ASME, 206

Auxiliary air, 228

auxiliary fuel, 228

## B

*balanced reaction*, 114

*basis*, 63

batch drying, 140

benzene, 53, 248

best efficiency point., 260

Betz's Law, 189

bioavailability, 84

Biochemical Oxygen Demand, 27, 125

biocides, 134

*Biodegradable*, 122

biogas, 234

biological phosphorus removal, 273

Biological transformations, 122

biological treatment, 153

biological yield coefficient, 125

biomass yield factor, 125

blending, 145

*block diagram*, 63

*block diagrams*, 16

blowdown, 133

blowdown, boiler, 75

blower air, 244

blowers, 272

BOD, 27

boiler, 75, 205

*boiler blowdown*, 162, 207

boiler efficiency, 205

boiler feed water, 206

boiler fuel consumption, 205

brake horsepower, 262

British thermal unit, 184

Btu, 184

## C

calcium, 134

calcium carbonate, 135

capital cost, 273

carbon dioxide, 219

Carnot engine, 182

catalyst, 241

*Catalytic incineration*, 241

centrifugal blower, 274

centrifugal pump, 259

*Chemical Oxygen Demand*, 28, 122

Chloride, 76, 129

chloromethane), 248

*Choke*, 274

clarifier, 125

- closed loop controllers, 273  
Coagulants, 49  
COD, 28  
Combustion, 219, 228  
combustion chamber, 228, 240  
combustion chamber volume, 247  
combustion equations, 243  
*composite concentration curve*, 173  
composite mass-concentration curve, 171  
compressors, 272  
concurrent heat exchanger, 210  
conductivity, 76, 131  
*Conservation of Energy*, 15, 178  
*Conservation of Mass*, 15, 59  
continuous stirred tank reactor, 151  
Continuous-flow reactors, 150  
conventional activated sludge, 273  
*cooling capacity*, 203  
cooling tower, 133, 163, 200  
*cooling tower blowdown*, 162  
*cooling tower effectiveness*, 202  
cooling tower efficiency, 202  
cooling water blowdown, 134  
corrosion inhibitors, 134  
countercurrent heat exchanger, 210  
countercurrent process, 78  
cross-stage process, 78  
CSTR, 151  
CSTRs in series, 154  
cumulative flow analysis, 144  
cumulative inflow curve, 144  
cumulative inflow curves, 144  
*cycles*, 164  
cycles of concentration, 75, 164
- D**  
Dalton's law of partial pressure, 38  
dead-rinse tank, 78  
*depuration*, 86  
detention pond, 141  
diffuser clogging, 275  
diffusers, 274  
digested sludge, 124



Join the best at  
the Maastricht University  
School of Business and  
Economics!

**Top master's programmes**

- 33<sup>rd</sup> place Financial Times worldwide ranking: MSc International Business
- 1<sup>st</sup> place: MSc International Business
- 1<sup>st</sup> place: MSc Financial Economics
- 2<sup>nd</sup> place: MSc Management of Learning
- 2<sup>nd</sup> place: MSc Economics
- 2<sup>nd</sup> place: MSc Econometrics and Operations Research
- 2<sup>nd</sup> place: MSc Global Supply Chain Management and Change

Sources: Keuzegids Master ranking 2013; Elsevier 'Beste Studies' ranking 2012; Financial Times Global Masters in Management ranking 2012

Maastricht University is the best specialist university in the Netherlands (Elsevier)

Visit us and find out why we are the best!  
Master's Open Day: 22 February 2014

[www.mastersopenday.nl](http://www.mastersopenday.nl)



dilution air, 246  
dimethylsiloxane, 131  
direct-contact condenser, 55  
discharge permit, 82  
discharge pressure, 274  
dissolved oxygen, 129, 273  
*Dissolved solids*, 25  
diurnal, 158  
domestic wastewater, 82  
*drag-out*, 76  
drift, 163  
drip tank, 77  
drive motor, 262  
*dry-bulb temperature*, 201  
Dust, 239  
*duty point*, 260

**E**

efficiency, 257  
*efficiency curve*, 259  
elbow, 263  
Empirical composition, 223  
empirical formula, 219  
empirical stoichiometry, 119, 126  
energy balance, 16, 177, 246, 249  
energy balances, 235  
Energy Conservative Design, 209  
energy conversion, 187  
energy integration, 209  
energy recovery efficiency, 248  
enthalpy, 193, 276  
enthalpy-temperature diagram, 218  
EPANet, 267  
epilimnion, 153  
equilibrium, 84  
equipment cost, 253  
*Evaporation*, 164  
excess air, 244  
explosion, 238  
extraction, 233

**F**

fill-draw cycle, 146  
filtrate, 57  
first law of thermodynamics, 178  
fixed solids, 235  
flammable range, 238  
flood control, 141  
flow equalization, 146  
flue gas, 228, 250  
fluid velocity, 263  
fly ash, 228  
FOB, 254  
forced draft, 163  
fossil fuel, 188, 228  
Free on board, 254  
*friction factor*, 263  
friction resistance, 260  
fumes, 222

**G**

gas migration, 233  
gas mixture, 38  
Gate valve, 263  
global warming potential, 230  
g-mole, 37  
*gram mole*, 114  
grand composite curve, 218  
gravitational constant, 263  
green house gases, 230  
greenhouse gas, 219

**H**

Hardness, 135  
hazardous organic compounds, 238  
hazardous waste, 121  
*head*, 259  
*head loss*, 263  
heat energy, 181, 245  
heat engines, 181  
heat exchange network, 214

Heat exchangers, 210  
Heat recovery, 235, 252  
heat transfer, 250  
heat transfer coefficient, 212  
heat transfer equation, 211  
heat trap, 181  
heating value, 249  
HEN, 214  
*Henry's Law*, 85  
*Henry's Law Constant*, 85  
heptane, 114  
higher heating value, 226  
HINT, 218  
horsepower, 184  
*hydraulic detention time*, 150  
hydraulic network, 266  
hydrochloric acid, 132, 248  
hydroelectric, 141  
hydrogen sulfide, 234, 243  
hydrolysis, 134  
hydro-turbine, 188  
hypolimnion, 153

## I

ideal gas law, 36  
Incineration, 228  
industrial wastewater, 82  
industrial water cycle, 162  
inlet air flow rate, 278  
Insolation, 190  
ion exchange, 62  
ionic charge, 119  
iterative, 155  
IUPAC), 34

## J

Joule, 184

## K

kilowatt, 184  
kinetic energy, 184, 260, 263

## L

landfill, 229  
landfill gas, 232  
*latent heat*, 195  
lb-mole, 37  
lead, 82, 118  
LEL, 238  
life-cycle cost, 266, 273  
log-mean temperature difference, 211  
low equalization, 144  
*Lower Explosive Limit*, 238  
lower explosive limits, 249  
lower heating value, 226  
Lower heating value of methane, 235

## M

Madison, 158  
maintenance cost, 273  
*makeup water*, 162  
manure digesters, 228  
mass flow rate, 61  
mass load, 148, 170  
material balance, 15, 16, 59, 140, 246  
*material balance equations*, 63  
*maximum flow rate*, 173  
membrane process, 50  
mercaptan, 243  
mesophilic anaerobic sludge digester, 234  
metal fabricating, 118  
methane, 124, 228, 234  
methane production, 230, 235  
methyl chloride, 131, 248  
microfiltration, 50  
minimum cost design, 269  
minimum temperature difference, 214  
mixing zone, 82  
molar mass, 37  
molar volume, 36  
*mole*, 114  
*molecular mass*, 114

motor efficiency, 268  
municipal solid waste, 224  
municipal wastewater treatment, 158

## N

natural draft, 163  
Natural gas, 228  
nearest neighbor rule, 168  
net heating value, 225  
Neutralization, 134  
*Newton*, 184  
NIST, 34  
nitric acid, 222  
nitrification, 273  
nitrification-denitrification, 273  
noble metal catalysts, 241  
non-contact condenser, 55  
Non-methane organic compounds, 231  
Normal cubic meter, 278  
*n*-stage counter current rinse, 80  
NTP, 34  
nuclear reactor, 188

numerical approximation, 156  
Numerical Solution, 155  
operating curve, 274  
operating cycle, 62  
operating head, 260  
operating point, 274  
operating pressure, 275  
optimization, 266  
overall material balance, 72

## P

particulate metal sulfides, 121  
*partition coefficients*, 85  
performance map, 274  
*PFR*, 150  
pH, 118  
Phenol, 53  
phosphorus, 138  
photovoltaic cell, 190  
*Pinch analysis*, 218  
*pinch point*, 174  
pinene, 242

> **Apply now**

REDEFINE YOUR FUTURE  
**AXA GLOBAL GRADUATE  
PROGRAM 2015**

redefining / standards 

agence.cdg. © Photonistop



- pipe fittings*, 263
- pipe roughness, 263
- pipng and instrumentation diagram*, 22
- plant walk-through, 76
- plug-flow reactor*, 150
- pollution audit, 53
- pollution prevention, 43
- polymer, 118
- potential energy, 184
- pound mole*, 114
- Power, 184, 252, 261, 276
- ppmv, 35
- preheater, 248, 249
- preliminary cost estimate, 253
- Present Value*, 269
- pressure drop, 252
- Pressure*, 259
- pretreatment regulations, 82
- priority pollutants, 82
- process dynamics, 140
- process flow sheet*, 20
- production cycle, 62
- pump curve*, 259, 260
- pump efficiency, 268
- Pumping, 257
- Pumping stations, 140
- purchased equipment costs, 253
- pyrene, 88
- quench water, 133
  
- R**
- range*, 202
- rate coefficient, 157
- reactor*, 150
- recirculating systems, 162
- recuperative thermal incinerator, 253
- regeneration, 161
- regenerative thermal oxidizer, 248
- renewable energy, 189
- residence time, 240, 241, 248
- residential solid waste, 223
- resin, ion exchange, 62
  
- return activated sludge, 125
- reuse, 161
- reverse osmosis, 62, 70
- Rinsing, 76
- runoff, 141
  
- S**
- Safety, 239
- scfd*, 40
- scmd*, 40
- second law of thermodynamics, 181
- sensible heat*, 194
- sensible heat flow, 251
- settling pond, 134
- sewer ordinances, 82
- shaft horsepower, 262
- shipping cost, 254
- shut-off head*, 260
- sludge, 82
- sludge digesters, 228
- sludge heating, 235
- Sludge mass, 121
- smoothing*, 145
- snowmelt, 141
- Sodium absorption ratio, 131
- Sodium sulfide, 118
- Soil-water partition coefficient, 88
- solar electric, 190
- solar energy, 190
- solar heating, 190
- solid waste, 223
- solid-liquid separation, 57
- solubility, 118
- solvents, 238
- specific gravity, 31, 126
- specific heat*, 194, 276
- specific heat capacity, 235
- standard conditions, 247
- static head*, 260
- static pressure, 275
- Steady state*, 61
- steady-state, 140

- steam, 75
- steam consumption, 207
- stoichiometric coefficients, 114, 219
- stoichiometric demand, 243
- stoichiometric equation, 114, 134, 219
- stoichiometric oxygen demand, 243
- Stoichiometry*, 114, 219
- storm water, 141
- STP, 34
- sulfide, 118
- Sulfuric acid, 222
- Surge*, 274
- Suspended solids*, 25
- Sweet Potato Canning, 45
- synthesis*, 14
- system cost, 268
- system curve, 260, 274
- system head curve, 263
- system power curve, 274
- T**
- tanks-in-series, 154
- temperature-phased anaerobic digestion*, 235
- THEN, 218
- Thermal incineration*, 240
- Thermal oxidation, 248
- thermal recovery efficiency*, 249
- thermodynamic pinch analysis, 218
- Thermophilic anaerobic digestion, 235
- tie component, 63
- ton of refrigeration, 203
- total dissolved solids, 75, 207
- total friction loss, 268
- Total solids*, 24, 122
- Toxicity, 82
- TPAD, 235
- tracer, 150
- turndown*, 274
- turndown limit*, 274
- turnover, 153
- turpentine, 243
- two-stage rinse, 78
- U**
- UEL, 238
- universal gas constant, 36
- Unsteady-state, 140
- Upper Explosive Limit*, 238
- Uranium 235, 188
- V**
- variable speed drives, 273
- variable speed pump, 261
- ventilation, 238, 249
- VOCs, 238
- volatile organic chemicals, 238, 248
- volatile solids, 122, 235
- volatile suspended solids, 126
- W**
- waste activated sludge, 125
- waste gas, 243
- waste heat, 181
- waste load allocation, 82
- Wastewater treatment, 272
- WatDis, 266, 287
- Water conservation, 161
- water power*, 262
- Water Reuse, 48
- water vapor, 226
- WaterCAD, 267
- water-effects ratio, 84
- Watt*, 184
- Watt-peak, 191
- wet well, 140
- wet-bulb temperature*, 201
- wind energy, 189
- wind turbine, 189
- Z**
- Zinc, 118